

brother

BAS-760

電子ポケットセッター 〈ジーンズ〉

AUTOMATIC POCKET SETTER <JEANS>

AUTOMATISCHE TASCHENNÄHMASCHINE <JEANS>

MACHINE A COUDRE AUTOMATIQUE POUR POCHE <JEANS>

MAQUINA DE COSER BOLSILLOS AUTOMATICA <JEANS>

パーツブック

PARTS BOOK

TEILEKATALOG

LIVRE DES PIECES

LIBRO DE REFERENCIA DE PIEZAS

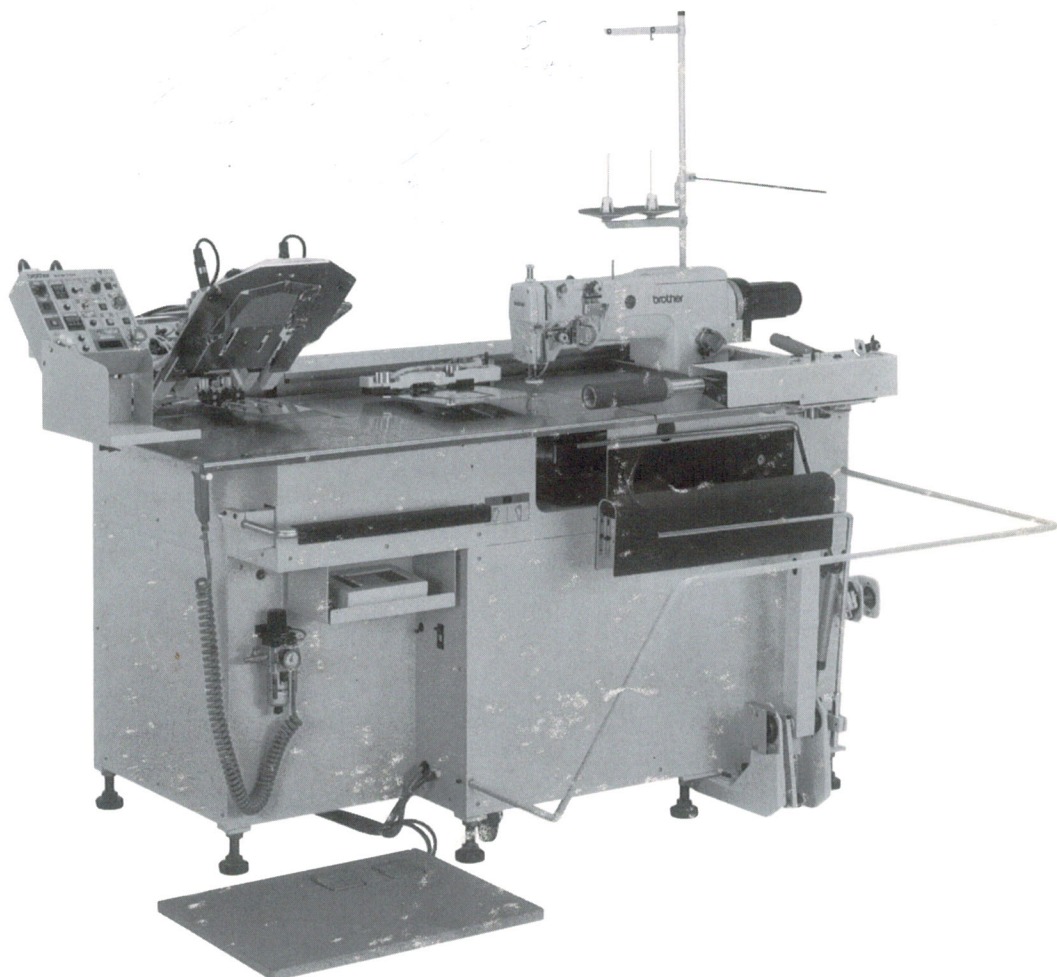

パーツブックご利用に際して

1. 組単位で補給する部品は、 破線で示しております。
2. この本は1992年2月のデータにもとづいて作成されたものです。
3. 部品は予告なしに設計変更される場合があります。
4. 部品コード欄が*となっている場合は、仕様別部品一覧表（113ページ）でお調べ下さい。

目 次

A. 主体関係	2	R. 糸切り関係	76
B. 針棒・天秤関係	4	S. 空圧関係	78
C. 針振関係	6	T. 電装品関係	86
D. 押エ関係	10	U. ボトム関係	94
E. 針板関係	12	V. プリント基板関係	94
F. 糸切レ感知関係	12	W. マーカー関係	96
G. スタッカー関係	14	X. モーター関係	98
H. 駆動側・送り関係	24	Y. 踏板関係	98
J. 送り案内関係	28	A 1. 動力台関係	100
K. 折り曲ゲ関係（特別注文部品）	30	B 1. 付属装置セット	104
L. 折り曲ゲ土台関係	60	C 1. 付属装置セット	110
M. カマ関係	64	Z 1. 付属品関係	110
N. 給油・潤滑関係	66	Z 2. 付属品関係	112
P. 糸通シ関係	70	仕様別部品一覧表	113
Q. 糸巻関係	74	索 引	115

Notes for using this parts book

1. Parts supplied as complete assemblies are circled by a dotted line  .
2. This book was prepared based on information available in February 1992.
3. Parts are subject to changes in design without prior notice.
4. If the symbol * is found in the "Parts No." column, refer to the different parts list on page 113.

CONTENTS

A . Machine body	2	R . Thread trimmer mechanism	76
B . Needle bar and thread take-up mechanism	4	S . Air pressure mechanism	78
C . Zigzag mechanism	6	T . Power supply equipment mechanism	86
D . Presser foot mechanism	10	U . Bottom mechanism	94
E . Needle plate mechanism	12	V . Printed circuit board mechanism	94
F . Thread breakage detector mechanism	12	W . Marker mechanism	96
G . Stacker mechanism	14	X . Motor mechanism	98
H . Drive, feed mechanism	24	Y . Foot switch pedal mechanism	98
J . Feed guide mechanism	28	A1. Power table	100
K . Folding margin mechanism (OPTION PARTS)	30	B1. Attachment set	104
L . Folding margin base mechanism	60	C1. Attachment set	110
M . Rotary hook mechanism	64	Z1. Accessories	110
N . Lubrication	66	Z2. Accessories	112
P . Threading mechanism	70	DIFFERENT PARTS LIST	113
Q . Bobbin winder mechanism	74	INDEX	115

Hinweise zur Verwendung dieser Teileliste

1. Die Teile, die als kompletter Satz geliefert werden, sind mit einer  gestrichelten Linie umrandet.
2. Dieses Buch basiert auf den Informationen vom Februar 1992.
3. Modelländerungen sind vorbehalten.
4. Dieses Zeichen * in der Spalte "Parts No. (Teilnummer)" verweist auf die Gesonderte Stückliste auf Seite 113.

INHALTSVERZEICHNIS

A . Maschinengehäuse	2	R . Fadenabschneidevorrichtung	76
B . Nadelstange und Fadenabnahmevorrichtung	4	S . Luftdruck	78
C . Zickzackvorrichtung	6	T . Stromversorgung	86
D . Stoffdrückerfuß	10	U . Unterer Mechanismus	94
E . Stichplattenmechanismus	12	V . Leiterplatten	94
F . Fadenbruchfühler	12	W . Markierungsvorrichtung	96
G . Anhäufung	14	X . Motor	98
H . Transportvorrichtung	24	Y . Fußbetätigung	98
J . Transportführung	28	A1. Motorgestell	100
K . Faltungsvorrichtung (SONDERZUBEHÖR)	30	B1. Anbausatz	104
L . Faltungsvorrichtungsgrundplatte	60	C1. Anbausatz	110
M . Greifervorrichtung	64	Z1. Zubehör	110
N . Schmierung	66	Z2. Zubehör	112
P . Fadenführungsvorrichtung	70	ZUBEHÖRLISTE	113
Q . Spuler	74	VERZEICHNIS	115

Notes sur l'utilisation de ce manuel de pièces détachées



1. Les pièces fournies en tant qu'assemblages complets sont encadrées avec un trait pointillé  .
2. Ce manuel a été fait d'après les renseignements valables au mois de Février 1992.
3. Les pièces peuvent être sujettes à des modifications sans préavis.
4. Si le symbole * se trouve dans la colonne "Parts No. (N° de pièce)" veuillez la vous référer à la liste de pièces annexe page 113.

TABLE DES MATIERES

A . Corps de la machine	2	R . Mécanisme de coupe-fil	76
B . Mécanisme de la barre à aiguille et releveur de fil	4	S . Mécanisme de la pression d'air	78
C . Mécanisme du zigzag	6	T . Mécanisme de l'équipement en alimentation électrique	86
D . Mécanisme du pied presseur	10	U . Mécanisme inférieur	94
E . Mécanisme de plaque à aiguille	12	V . Circuits imprimés	94
F . Mécanisme du détecteur de cassure du fil	12	W . Mécanisme du marqueur	96
G . Mécanisme de l'empileur	14	X . Mécanisme du moteur	98
H . Mécanisme d'alimentation, entraînement	24	Y . Mécanisme de la pédale	98
J . Mécanisme du guide de l'entraînement ..	28	A1. Mécanisme du plateau de la machine	100
K . Mécanisme de marge d'ourlet (PIÈCES EN OPTION)	30	B1. Jeu d'accessoires	104
L . Mécanisme de base de marge d'ourlet	60	C1. Jeu d'accessoires	110
M . Mécanisme du crochet rotatif	64	Z1. Accessoires	110
N . Lubrification	66	Z2. Accessoires	112
P . Mécanisme de l'enfilage	70	LISTE DE PIÈCES ACCESSOIRES	113
Q . Mécanisme du bobineur	74	INDEX	115

Notas para usar este Manual de Piezas

1. Las piezas suministradas como conjuntos completos se enmarcan con una línea punteada  .
2. Este libro ha sido compilado basándose en los datos de que se disponía en febrero 1992.
3. Las piezas quedan sujetas a cambios de diseño sin aviso previo.
4. De haber un símbolo * junto al "Parts No. (Número de Pieza)", habrá que mirar la lista de piezas separada de la página 113.

INDICE

A . Cuerpo de la máquina	2	R . Mecanismo de la cortadura de hilos	76
B . Mecanismo de la barra de aguja y tirahilos	4	S . Mecanismo de la presión de aire	78
C . Mecanismo del zigzag	6	T . Mecanismo del equipo de alimentación de corriente	86
D . Mecanismo de la prensatelas	10	U . Mecanismo del fondo	94
E . Mecanismo de la placa de aguja	12	V . Tableros de circuitos impresos	94
F . Mecanismo del sensor de cortes de hilo ..	12	W . Mecanismo del marcador	96
G . Mecanismo de apilador	14	X . Mecanismo del motor	98
H . Mecanismo de alimentación, mando	24	Y . Mecanismo del pedal	98
J . Mecanismo de la guía de alimentación ...	28	A1. Mecanismo de la mesa de la máquina	100
K . Mecanismo de margen de plegado (PIEZAS OPCIONALES)	30	B1. Juego de fijación	104
L . Mecanismo base de margen de plegado ..	60	C1. Juego de fijación	110
M . Mecanismo del cangrejo	64	Z1. Accesorios	110
N . Lubricación	66	Z2. Accesorios	112
P . Mecanismo del enhebrado	70	LISTA DE PIEZAS ACCESORIAS	113
Q . Mecanismo del devanador de la canilla ..	74	INDICE	115

A. 主体関係 / Machine body / Maschinengehäuse /
 Corps de la machine / Cuerpo de la máquina

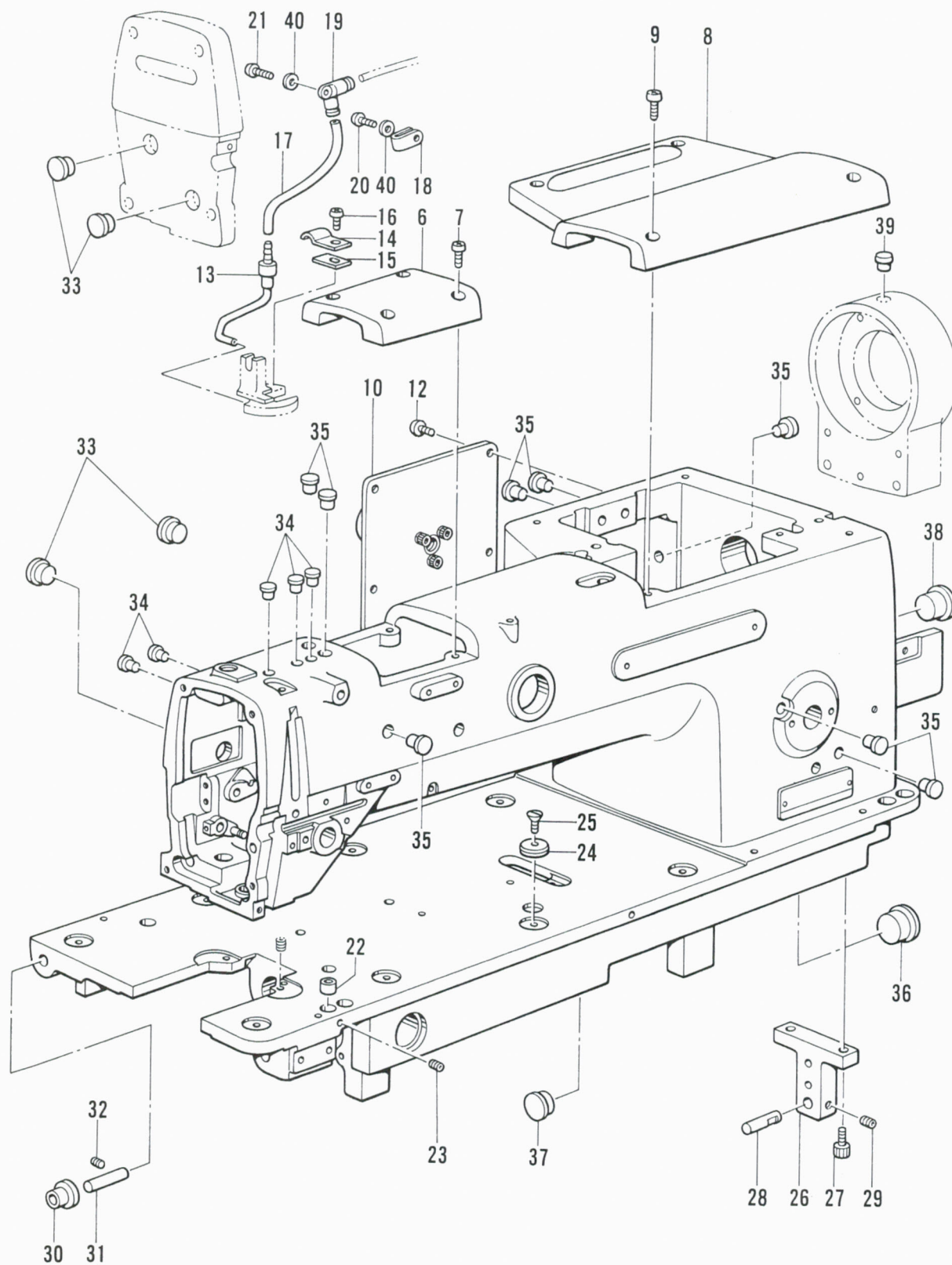

A. 主体関係/Machine body/Maschinengehäuse/
Corps de la machine/Cuerpo de la máquina

REF.NO.	CODE	Q'TY	ヒンメイ	NAME OF PARTS	RMKS
6	S24695009	1	ウフフ"タS	TOP COVER (S)	
7	062401012	4	ナヘ"コM4X10	SCREW M4X10	
8	S24696009	1	ウフフ"タL	TOP COVER (L)	
9	062401012	4	ナヘ"コM4X10	SCREW M4X10	
10	S29885009	1	ガ"ワイタクミ	REAR COVER ASSEMBLY	
12	062401212	4	ナヘ"コ4X12	SCREW 4X12	
13	S24699001	1	スレツト"フ"ロワー	THREAD BLOWER	
14	S00955001	1	パイプ"ササエイタ	PIPE SUPPORT PLATE	
15	159690001	1	オクリカムストツパー	FEED CAM STOPPER	
16	062670612	1	ナヘ"コ357-40X6	SCREW 357X6	
17	S14495000	1	エアホース4X2.5	AIR TUBE 4X2.5 (L=115)	
18	149547000	1	コード"オサエ4N	CORD HOLDER (4N)	
19	S01201000	1	エルボ"	ELBOW	
20	062401006	1	ナヘ"コ4X10	SCREW 4X10	
21	062401416	1	ナヘ"コ4X14	SCREW 4X14	
22	S11856001	2	イチキ"メメタル	POSITIONING BUSH	
23	014400422	2	アナトメネシ"4X4クホ"ミ	SET SCREW 4X4	
24	S11857000	4	ハリイタウケ	NEEDLE PLATE SUPPORT	
25	107272002	4	サラネシ"4.37	SCREW 4.37	
26	S24700001	1	トウフ"ササエタイ	HEAD SUPPORT STUD	
27	018501622	2	アナボ"ルト5X16	BOLT 5X16	
28	152866001	1	トウフ"ササエピン	PIN	
29	014500522	1	アナトメネシ"5クホ"ミ	SET SCREW 5	
30	152868009	2	ヘ"ツト"ヒンジ"クツシヨン	HINGE CUSHION	
31	152867000	2	ヘ"ツト"ヒンジ"シク	HINGE SHAFT	
32	014500522	2	アナトメネシ"5クホ"ミ	SET SCREW 5	
33	104449009	4	メクラセン	OIL CAP	
34	104450109	5	メクラセン	OIL CAP	
35	104821009	8	メクラセン	OIL CAP	
36	147251009	1	メクラセン	OIL CAP	
37	150756009	1	メクラセン	OIL CAP	
38	158882009	1	メクラセン	OIL CAP	
39	104821001	1	メクラセン	OIL CAP	
40	025040233	2	ヒラサ"ガ"ネチユウ4	PLAIN WASHER 4	

B. 針棒・天秤関係 / Needle bar and thread take-up mechanism / Nadelstange und Fadenabnahmevorrichtung / Mécanisme de la barre à aiguille et releveur de fil / Mecanismo de la barra de aguja y tirahilos

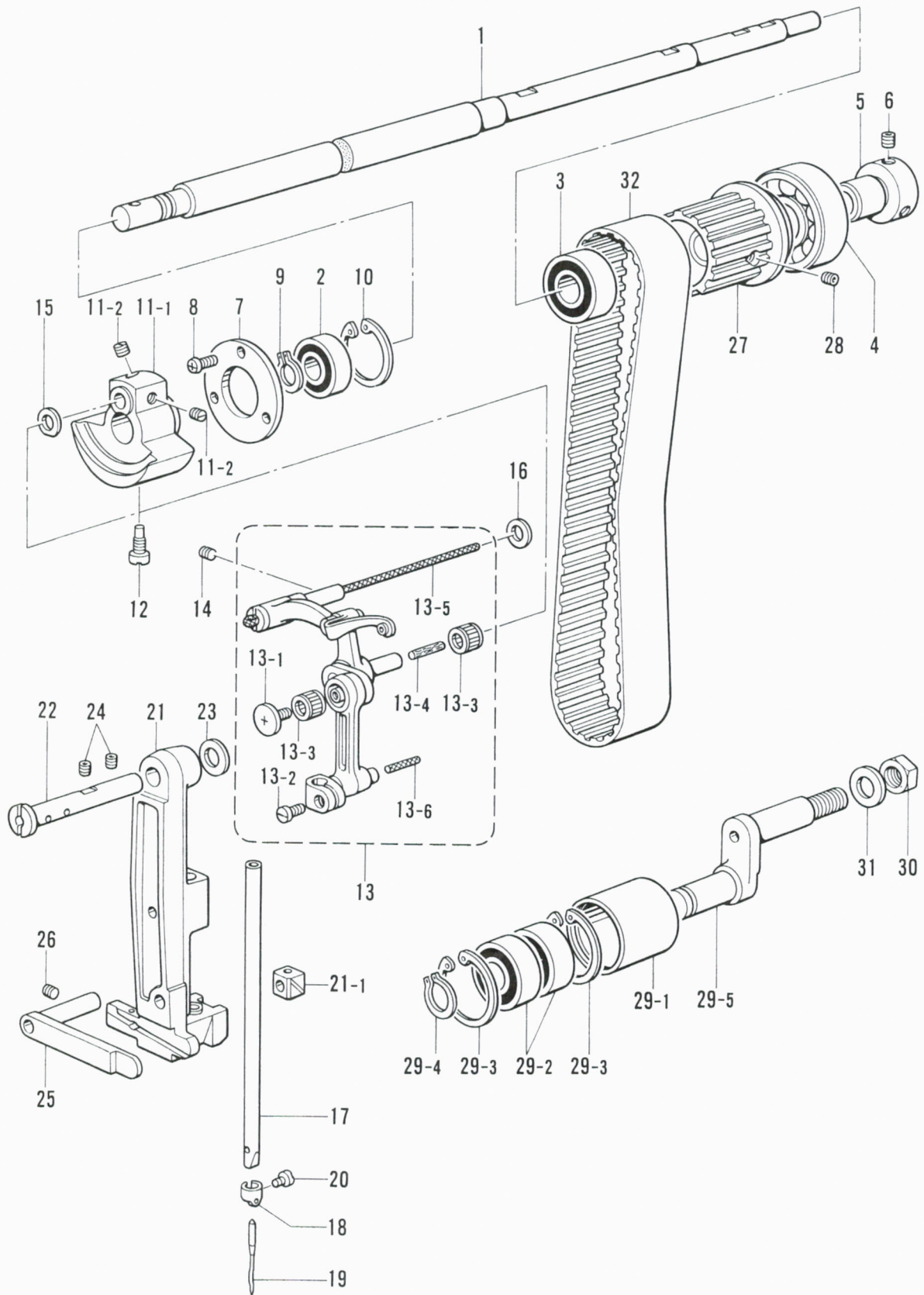

B. 針棒・天秤関係 / Needle bar and thread take-up mechanism / Nadelstange und Fadenabnahmeverrichtung /
Mécánisme de la barre à aiguille et releveur de fil / Mecanismo de la barra de aguja y tirahilos

REF.NO.	CODE	Q'TY	ヒンメイ	NAME OF PARTS	RMKS
1	S24701001	1	ウウジ"ク	UPPER SHAFT	
2	S11921000	1	タマジ"クウケ6002DDU	BALL BEARING 6002DDU	
3	S11922000	1	タマジ"クウケ6003DDU	BALL BEARING 6003DDU	
4	S24702000	1	タマジ"クウケ6304DDU	BALL BEARING 6304DDU	
5	S24703001	1	タマジ"クウケカラー	BALL BEARING COLLAR	
6	100251001	2	トメネジ"6.35	SET SCREW 6.35	
7	S11863001	1	タマジ"クウケオサエ	BALL BEARING SUPPORT	
8	062401012	3	ナヘ"コM4X10	SCREW M4X10	
9	048150142	1	トメワジ"クヨウC15	STOP RING C15	
10	048320242	1	トメワアナヨウC32	STOP RING C32	
11	S00909001	1	デンビ"ンクランククミ	THREAD TAKE-UP CRANK ASSEMBLY	
11-1	S00910000	1	デンビ"ンクランク	THREAD TAKE-UP CRANK	
11-2	100251001	2	トメネジ"6.35	SET SCREW 6.35	
12	104464001	1	シメネジ"7.14	SCREW 7.14	
13	S02534101	1	ハリホ"ウレンカンクミ	THREAD TAKE-UP LEVER ASSEMBLY	
13-1	145465001	1	シメネジ"3.57L	SCREW 3.57 (L)	
13-2	140004001	1	シメネジ"3.57	SCREW 3.57	
13-3	147777000	2	ニート"ルヘ"アリング"	NEEDLE BEARING	
13-4	145624000	1	フェルト	FELT	
13-5	158726001	1	クミヒモ4X4	WICK (L=120,4X4)	
13-6	158727001	1	クミヒモ4X4	WICK (L=27,4X4)	
14	013781012	1	トメネジ"6.35クホ"ミ	SET SCREW 6.35	
15	110367001	1	サ"カ"ネ	WASHER	
16	105077000	1	サ"カ"ネ	WASHER	
17	S24704001	1	ハリホ"ウ	NEEDLE BAR	
18	151594001	1	ハリホ"ウイトアンナイ	NEEDLE BAR THREAD GUIDE	
19	S24705005	1	ミシンハリ1955-01	NEEDLE 1955-01	
20	140553102	1	アタマツキトメネジ"3.18	SET SCREW 3.18	
21	S24706001	1	ハリホ"ウダ"イクミ	NEEDLE BAR BRACKET ASSEMBLY	
21-1	159624001	1	ハリホ"ウダ"イカクコマ	NEEDLE BAR BRACKET SLIDE BLOCK	
22	S24708001	1	ハリホ"ウダ"イササエジ"ク	SUPPORT SHAFT	
23	142628001	1	スイヘイオクリクランクリング"	FEED ROCK CRANK RING	
24	013781012	2	トメネジ"6.35クホ"ミ	SET SCREW 6.35	
25	158889001	1	ハリホ"ウダ"イアンナイ	NEEDLE BAR BRACKET GUIDE	
26	013781012	1	トメネジ"6.35クホ"ミ	SET SCREW 6.35	
27	159744100	1	Uタイミング"プー"リクミ	UPPER TIMING PULLEY ASSEMBLY	
28	014760622	4	アトメネジ"5.95	SET SCREW 5.95	
29	158906001	1	アイト"ラプー"リクミ	IDLER PULLEY ASSEMBLY	
29-1	158907001	1	アイト"ラプー"リ	IDLER PULLEY	
29-2	072620260	2	タマジ"クウケ6202VVC2	BALL BEARING 6202VVC2	
29-3	048350242	2	トメワアナヨウC35	STOP RING C35	
29-4	048150142	1	トメワジ"クヨウC15	STOP RING C15	
29-5	158908001	1	アイト"ラプー"リウデ"	IDLER PULLEY ARM	
30	158909001	1	ナツト12.7ヒタ"リ	NUT 12.7 (LEFT)	
31	025900232	1	ヒラサ"カ"ネチユウ12.70	PLAIN WASHER 12.70	
32	S24711000	1	タイミング"ヘ"ルト	TIMING BELT	
<オプション / FOR OPTION>					
19	S24705002	1	ミシンハリ1955-01	NEEDLE 1955-01	
19	S24705003	1	ミシンハリ1955-01	NEEDLE 1955-01	
19	S24705004	1	ミシンハリ1955-01	NEEDLE 1955-01	
19	S24705006	1	ミシンハリ1955-01	NEEDLE 1955-01	

C. 針振關係 / Zigzag mechanism / Zickzackvorrichtung /
 Mécanisme du zigzag / Mecanismo del zigzag

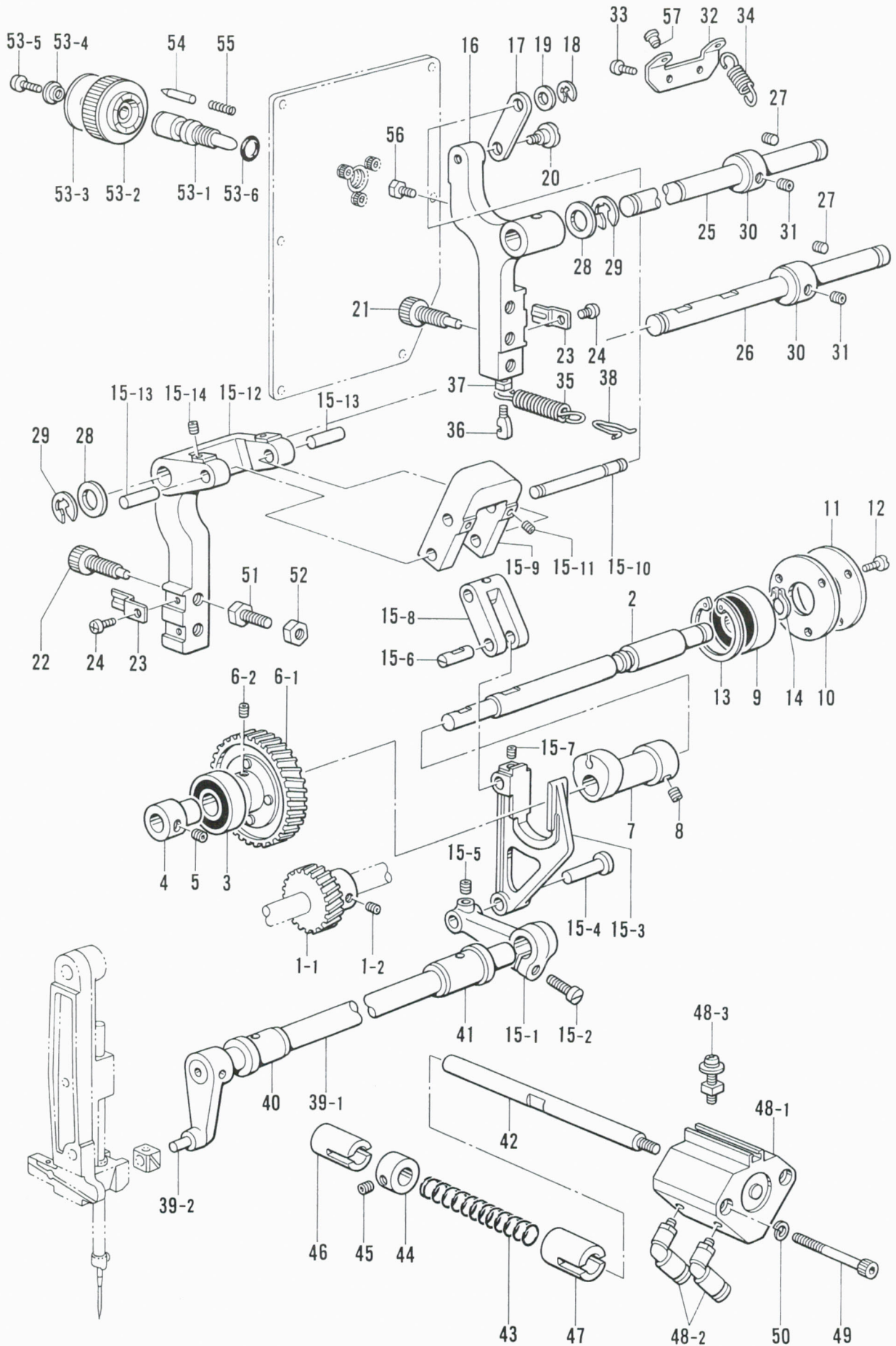

C. 針振関係/Zigzag mechanism/Zickzackvorrichtung/
Mécanisme du zigzag/Mecanismo del zigzag

REF.NO.	CODE	Q'TY	ヒンメイ	NAME OF PARTS	RMKS
1	183702001	1	ケ"ソクキ"ヤクミ	SPPED REDUCTION GEAR ASSEMBLY	
1-1	141309001	1	ケ"ソクキ"ヤ	SPEED REDUCTION GEAR	
1-2	014770622	2	アトメネシ"6.35クホ"ミ	SET SCREW 6.35	
2	S24712001	1	フクシ"ク	SUB SHAFT	
3	S11922000	1	タマシ"クウケ6003DDU	BALL BEARING 6003DDU	
4	S24713001	1	タマシ"クウケカラー	BALL BEARING COLLAR	
5	014770622	2	アトメネシ"6.35クホ"ミ	SET SCREW 6.35	
6	183707001	1	フクシ"クキ"ヤクミ	SUB SHAFT GEAR ASSEMBLY	
6-1	158917001	1	フクシ"クキ"ヤクミ	SUB SHAFT GEAR ASSEMBLY	
6-2	014770622	2	アトメネシ"6.35クホ"ミ	SET SCREW 6.35	
7	S24714001	1	ハリフリカム	ZIGZAG CAM	
8	014770622	2	アトメネシ"6.35クホ"ミ	SET SCREW 6.35	
9	072630140	1	タマシ"クウケ6301 DDU	BALL BEARING 6301 DDU	
10	S24715001	1	タマシ"クウケオサエ	BALL BEARING PRESSER	
11	S24746009	1	タマシ"クウケカバー	BALL BEARING COVER	
12	105176001	3	シメネシ"4.37	SCREW 4.37	
13	048370242	1	トメフアナヨウC37	STOP RING C37	
14	048120142	1	トメフシ"クヨウC12	STOP RING C12	
15	S24716001	1	ハリフリキクミ	ZIGZAG ADJUST CAM ASSEMBLY	
15-1	158947001	1	ハリフリレハ"ーR	ZIGZAG ADJUST LEVER (R)	
15-2	S01304001	1	シメネシ"6.35X18	SCREW 6.35X18	
15-3	158920001	1	ハリフリフタマタ	ZIGZAG ADJUST FORK	
15-4	158921001	1	ハリフリフタマタシ"ク	ZIGZAG ADJUST FORK STUD	
15-5	014770622	1	アトメネシ"6.35クホ"ミ	SET SCREW 6.35	
15-6	158922001	1	フタマタリンクピン	PIN	
15-7	014680622	1	アトメネシ"4.37クホ"ミ	SET SCREW 4.37	
15-8	158923001	1	ハリフリリンク	ZIGZAG ADJUST LINK	
15-9	158924001	1	キシ"ユニイチヘンカンリンク	LINK	
15-10	158925001	1	ハリフリキシ"ユニシ"ク	ZIGZAG ADJUST SHAFT	
15-11	014680622	2	アトメネシ"4.37クホ"ミ	SET SCREW 4.37	
15-12	S24717000	1	キシ"ユニイチチヨウセツウデ"	ADJUST ARM	
15-13	158927001	2	ヘンカンリンクシテンシ"ク	FULCRUM SHAFT	
15-14	014680622	2	アトメネシ"4.37クホ"ミ	SET SCREW 4.37	
16	S24718000	1	ハリフリチヨウセツウデ"	ZIGZAG ADJUST ARM	
17	158926001	1	フリハハ"ヘンカンリンク	ZIGZAG ADJUST LINK	
18	048050342	1	トメフE5	STOP RING E5	
19	153138001	1	サ"カ"ネ	WASHER	
20	145480001	1	タ"ンネシ"6.35	STUD SCREW 6.35	
21	158930001	1	ハリフリチヨウセツネシ"	ZIGZAG ADJUST SCREW	
22	159906001	1	カント"メチヨウセツネシ"	BAR TACKING ADJUST SCREW	
23	158931001	2	ハリフリチヨウセツネシ"オサエ	ZIGZAG ADJUST SCREW PRESSER	
24	062680512	2	ナヘ"コ437-40X5	SCREW 437X5	
25	158929001	1	チヨウセツウデ"シ"クA	ADJUST ARM SHAFT (A)	
26	158933001	1	チヨウセツウデ"シ"クB	ADJUST ARM SHAFT (B)	
27	014760622	2	アトメネシ"5.95	SET SCREW 5.95	
28	115007001	2	サ"カ"ネ	WASHER	
29	146293001	2	トメフE10	STOP RING E10	
30	117671002	2	セツトカラー	SET COLLAR	
31	014770622	4	アトメネシ"6.35クホ"ミ	SET SCREW 6.35	
32	159426001	1	ハリフリハ"ネカケ	SPRING HOOK	
33	062681012	2	ナヘ"コ437-40X10	SCREW 437X10	
34	158935001	1	ハリフリハ"ネA	SPRING (A)	
35	143609001	1	キリカエキハ"ネ	FEED REGULATOR SPRING	
36	141334001	1	ハ"ネカケ	SPRING HOOK	
37	100022005	1	ナツト5.95	NUT 5.95	
38	158940001	1	ハ"ネカケ	SPRING HOOK	
39	S24719001	1	ハリフリレハ"ーFクミ	ZIGZAG LEVER (F) ASSEMBLY	
39-1	S24720001	1	ハリフリレハ"ーシ"ク	ZIGZAG LEVER SHAFT	
39-2	159625001	1	レハ"ーFカクコマシ"ク	ZIGZAG LEVER (F) STUD	
40	S24721000	1	ハリフリシ"クメタルF	ZIGZAG LEVER SHAFT BUSH (F)	
41	158946001	1	ハリフリシ"クメタルR	ZIGZAG LEVER SHAFT BUSH (R)	
42	S24722001	1	ハリフリオシホ"ウ	ZIGZAG CONNCTING SHAFT	

C. 針振關係 / Zigzag mechanism / Zickzackvorrichtung /
 Mécanisme du zigzag / Mecanismo del zigzag

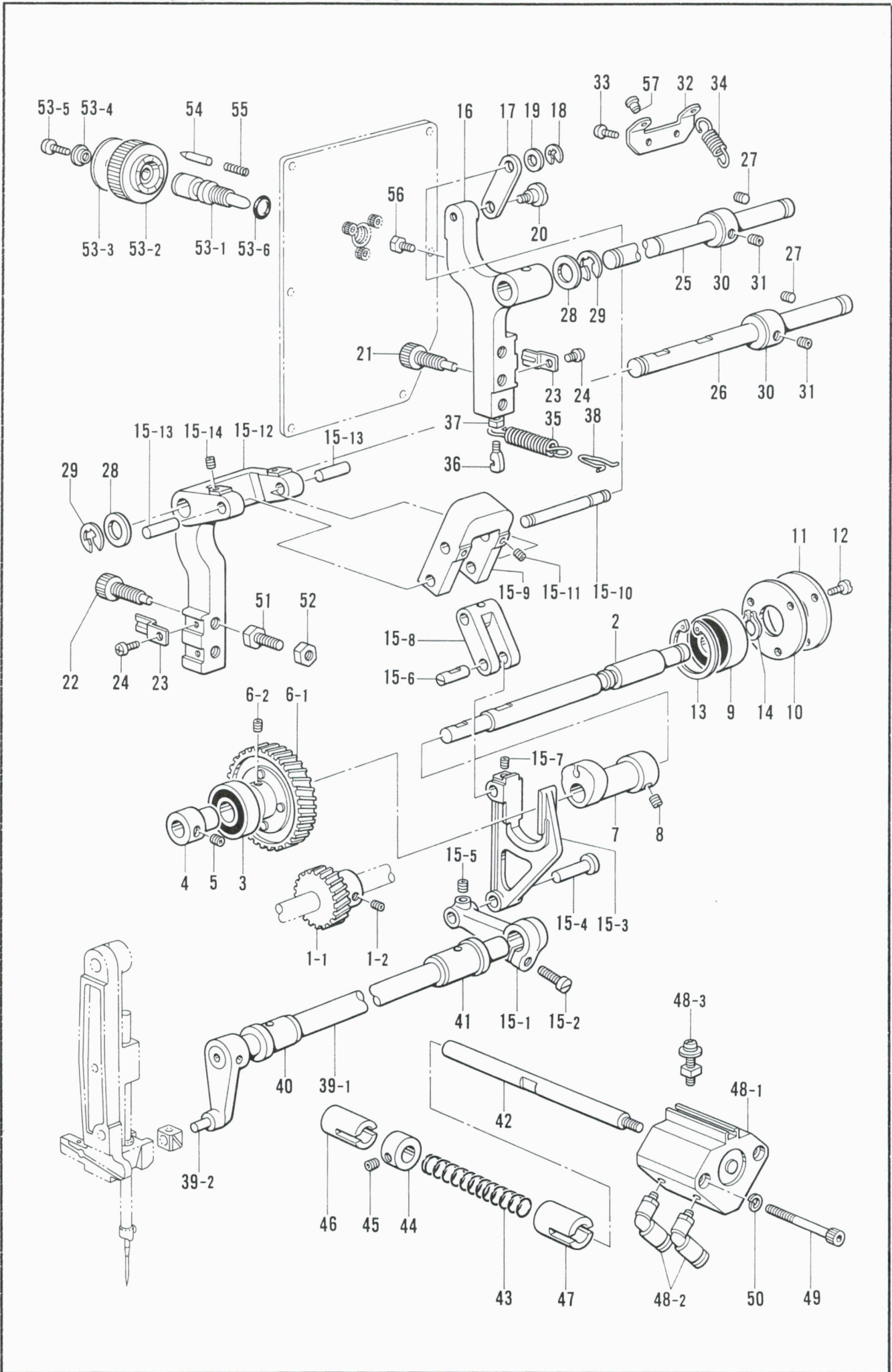

C. 針振関係/Zigzag mechanism/Zickzackvorrichtung/
Mécanisme du zigzag/Mecanismo del zigzag

REF.NO.	CODE	Q'TY	ヒンメイ	NAME OF PARTS	RMKS
43	S24723001	1	ハリフリオシホ"ウハ"ネ	SPRING	
44	146581001	1	セツトカラー	SET COLLAR	
45	014760622	2	アナトメネシ"5.95	SET SCREW 5.95	
46	S24724000	1	ハリフリオシホ"ウメタルS	ZIGZAG ADJUST BAR BUSH (S)	
47	S24725000	1	ハリフリオシホ"ウメタルL	ZIGZAG ADJUST BAR BUSH (L)	
48	S24726000	1	ハリフリシリンドラ"クミ	ZIGZAG CYLINDER ASSEMBLY	
48-1	S24727000	1	ハリフリシリンドラ"	ZIGZAG CYLINDER	
48-2	S11426000	2	エルボ"ユニオン4M5	ELBOW UNION 4M5	
48-3	S24728000	1	スイッチトリツケカナク"	SWITCH TABLE ANGLE	
49	S24729000	2	CQ2ボ"ルトM5X45	CQ2 BOLT M5X45	
50	028050243	2	ハ"ネサ"カ"ネ2-5	SPRING WASHER 2-5	
51	017771412	1	ボ"ルト6.35X14	BOLT 6.35X14	
52	150554002	1	ナツト6.35	NUT 6.35	
53	S24731009	1	ハリフリメモリイタクミ	ZIGZAG DIAL ASSEMBLY	
53-1	S06999001	1	オクリチヨウセツネシ"	ADJUST SCREW	
53-2	129500010	1	オクリメモリイタイ	STITCH LENGTH CONTROL DIAL	
53-3	S24732009	1	ハリフリメモリイタ	ZIGZAG DIAL	
53-4	142746002	1	メモリイタオサエ	LENGTH CONTROL PLATE SUPPORT	
53-5	129458002	1	シメネシ"4.76	SCREW 4.76	
53-6	108549001	1	O"リング"	O RING	
54	145502001	1	メモリイチキ"メピン	POSITIONING PIN	
55	100328001	1	メモリイチキ"メピンハ"ネ	SPRING	
56	151276001	1	ボ"ルト3.57	BOLT 3.57	
57	111865009	1	オイルメクラセン	OIL CAP	

D. 押工関係/Presser foot mechanism/Stoffdrückerfuß/
 Mécanisme du pied presseur/Mecanismo de la prensatelas

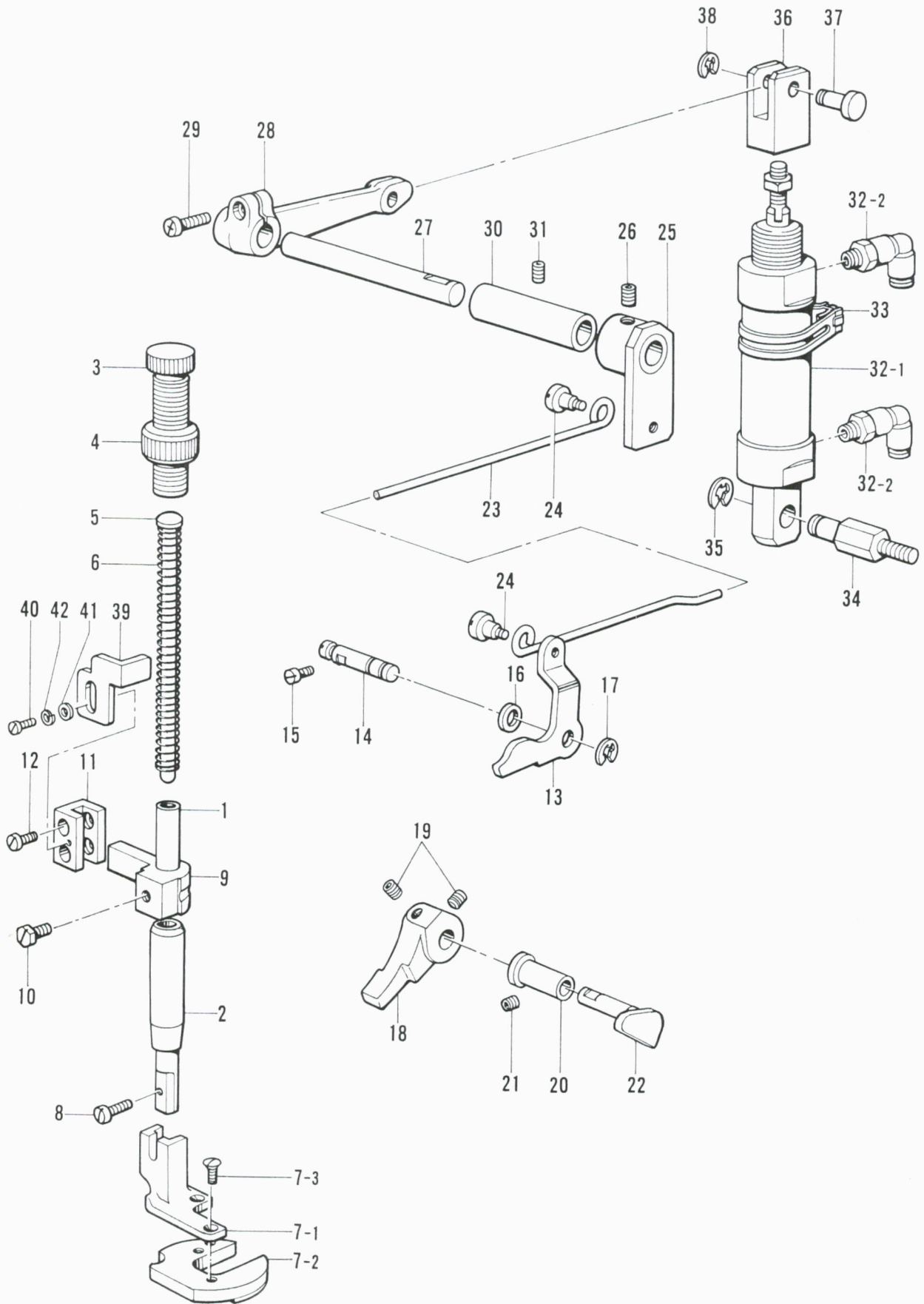

D. 押工関係/Presser foot mechanism/Stoffdrückerfuß/
Mécánisme du pied presseur/Mecanismo de la prensatelas

REF.NO.	CODE	Q'TY	ヒンメイ	NAME OF PARTS	RMKS
1	111466001	1	オサエボ"ウ	PRESSER BAR	
2	145472001	1	オサエボ"ウメタル	PRESSER BAR BUSH	
3	141207001	1	オサエチヨウセツネジ"	ADJUST SCREW	
4	147846002	1	チヨウセツネジ"ツマミナツト	NUT	
5	S24740001	1	オサエハ"ネアンナイ	SPRING GUIDE	
6	S24741001	1	オサエハ"ネ	SPRING	
7	S24742001	1	オサエアシクミ	WORK CLAMP ASSEMBLY	
7-1	S24743001	1	オサエアシ	WORK CLAMP	
7-2	S24744000	1	オサエイタ	PRESSER PLATE	
7-3	102843004	2	サラネジ"3.57	SCREW 3.57	
8	S13385001	1	シメネジ"3.57X10	SCREW 3.57X10	
9	S24745000	1	オサエボ"ウダ"キ	PRESSER BAR GUIDE CLAMP	
10	142403001	1	ボ"ルト5.95	BOLT 5.95	
11	S11871101	1	オサエボ"ウダ"キウケ	PRESSER BAR GUIDE BRACKET SUPPORT	
12	S11872001	2	シメネジ"4	SCREW 4	
13	145580001	1	オサエアケ"レハ"ー	PRESSER BAR LIFTER LEVER	
14	145474001	1	オサエアケ"レハ"ー"シク	PRESSER BAR LIFTER LEVER SHAFT	
15	S01998001	1	アタマツキトメネジ"3.57	SET SCREW 3.57	
16	S02302001	1	オサエアケ"カンザ"	WORK CLAMP LIFTER SPACER	
17	048040342	1	トメワE4	STOP RING E4	
18	S24747009	1	オサエアケ"テコ	PRESSER BAR LIFTER	
19	014710522	2	アタメネジ"4.76クホ"ミ	SET SCREW 4.76	
20	S11883001	1	オサエアケ"クランクメタル	PRESSER BAR LIFTER CRANK BUSH	
21	014400422	1	アタメネジ"4X4クホ"ミ	SET SCREW 4X4	
22	S02551001	1	オサエアケ"クランク	PRESSER BAR LIFTER CRANK	
23	S24748001	1	オサエアケ"レンカン	PRESSER CONNECT ROD	
24	145478001	2	ダ"ンネジ"4.76	STUD SCREW 4.76	
25	S11874001	1	オサエアケ"ウテ"	PRESSER BAR LIFTER ARM	
26	014770622	2	アタメネジ"6.35クホ"ミ	SET SCREW 6.35	
27	S24749001	1	ヨウト"ウレンカンシク	ROCKING CONNECT ROD SHAFT	
28	S11876001	1	レハ"ー	LEVER	
29	062711412	1	ナヘ"コ476-32X14	SCREW 476X14	
30	146629000	1	レハ"ー"ジクメタルL	LEVER SHAFT BUSH (L)	
31	014500522	1	アタメネジ"5クホ"ミ	SET SCREW 5	
32	S24751000	1	オサエアケ"シリンタ"クミ	PRESSER BAR LIFTER CYLINDER ASSEMBLY	
32-1	S24752000	1	オサエアケ"シリンタ"	PRESSER BAR LIFTER CYLINDER	
32-2	S04909000	2	エルホ"ユニオン	ELBOW UNION	
33	S11880000	1	スイッチトリツケカナグ"20	SWITCH SET METAL FITTING 20	
34	S11881001	1	シリンタ"ササエ	CYLINDER SUPPORT	
35	048070342	1	トメワE7	STOP RING E7	
36	S11882009	1	シリンタ"ツキ"テ	CYLINDER JOINT	
37	146153001	1	リンクピン	PIN	
38	048040342	1	トメワE4	STOP RING E4	
39	S20816001	1	オサエストツパ"ー	PRESSER STOPER	
40	100257010	1	シメネジ"3.57	SCREW 3.57	
41	025350132	1	ヒラサ"カ"ネシヨウ	PLAIN WASHER	
42	028350242	1	ハ"ネサ"カ"ネ2-3.5	SPRING WASHER 2-3.5	

E. 針板関係 / Needle plate mechanism / Stichplattenmechanismus /
 Mécanisme de plaque à aiguille / Mecanismo de la placa de aguja

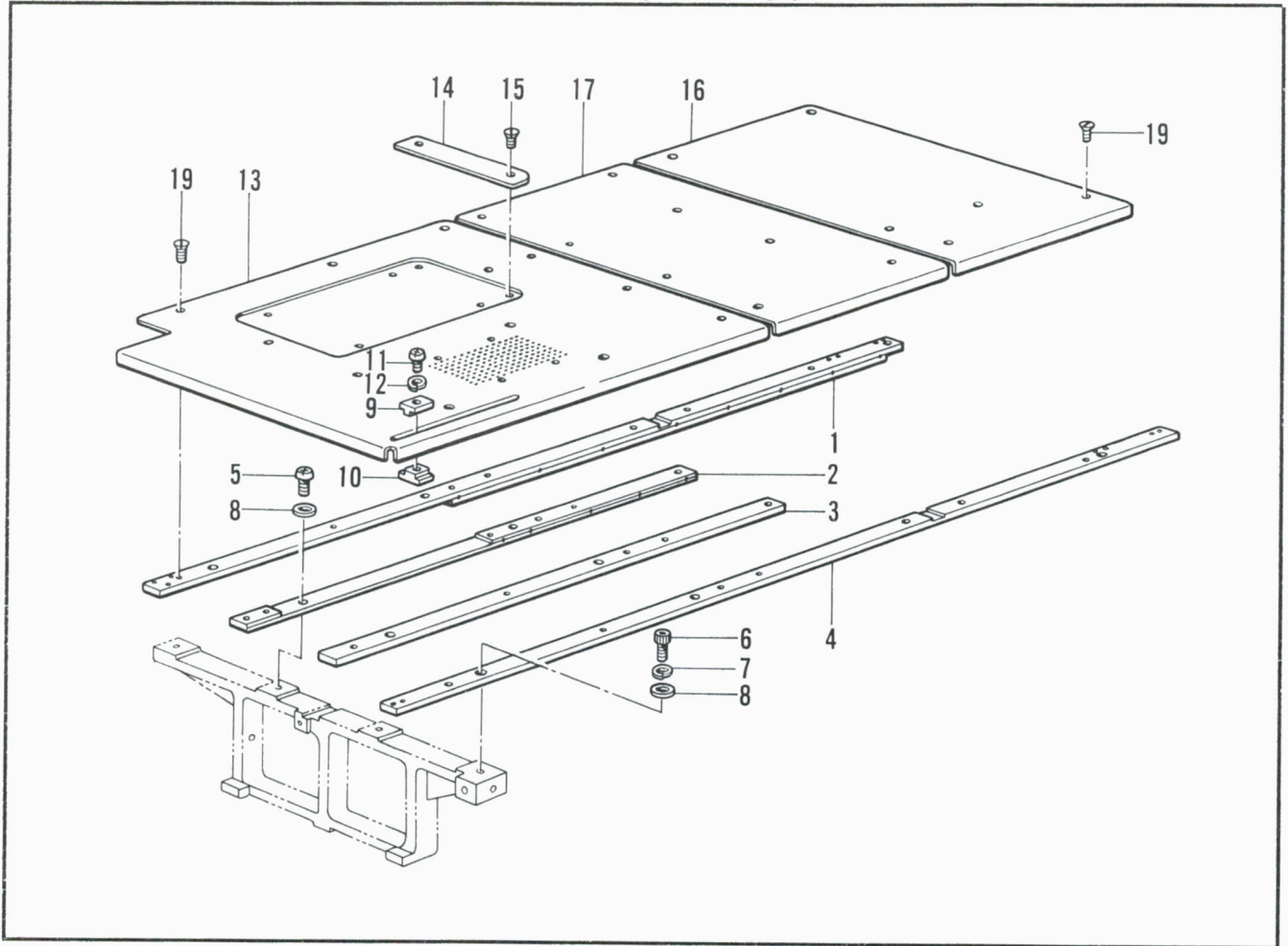

F. 糸切れ感知関係 / Thread breakage detector mechanism / Fadenbruchfühler /
 Mécanisme du détecteur de cassure du fil / Mecanismo del sensor de cortes de hilo

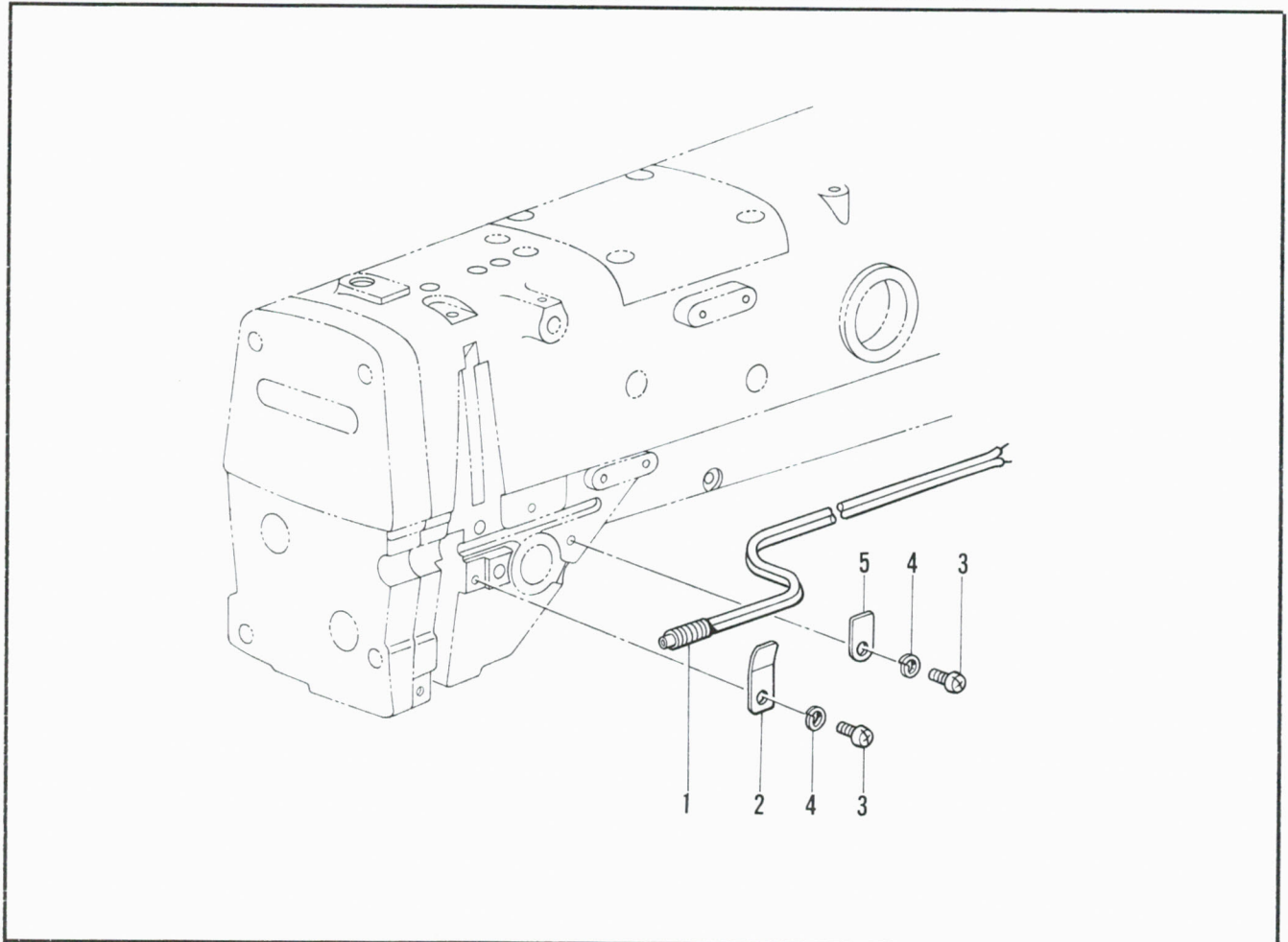

E. 針板関係 / Needle plate mechanism / Stichplattenmechanismus /
 Mécanisme de plaque à aiguille / Mecanismo de la placa de aguja

REF.NO.	CODE	Q'TY	ヒンメイ	NAME OF PARTS	RMKS
1	S24733001	1	ハリイタササエ1	NEEDLE PLATE SUPPORT 1	
2	S24734001	1	ハリイタササエ2	NEEDLE PLATE SUPPORT 2	
3	S24776001	1	ハリイタササエ3	NEEDLE PLATE SUPPORT 3	
4	S24735001	1	ハリイタササエ4	NEEDLE PLATE SUPPORT 4	
5	062501202	1	ナヘ"コM5X12	SCREW M5X12	
6	018501222	9	アナホ"ルト5X12	BOLT 5X12	
7	028050242	9	ハ"ネサ"カ"ネ2-5	SPRING WASHER 2-5	
8	025050232	10	ヒラサ"カ"ネチユウ-5	PLAIN WASHER 5	
9	S11966001	1	イチキ"メウエ	POSITIONING UPPER	
10	S11967001	1	イチキ"メシタ	POSITIONING LOWER	
11	062400616	1	ナヘ"コM4X6	SCREW M4X6	
12	028040243	1	ハ"ネサ"カ"ネ2-4	SPRING WASHER 2-4	
13	S24736000	1	ハリイタタ"イル	NEEDLE PLATE (L)	
14	S24737000	1	ハリイタスヘ"ーサA	NEEDLE PLATE SPACER (A)	
15	102843004	2	サラネジ"3.57	SCREW 3.57	
16	S24738100	1	ハリイタタ"イRR	NEEDLE PLATE (RR)	
17	S24739100	1	ハリイタタ"イRL	NEEDLE PLATE (RL)	
19	100032003	24	サラネジ"4.37	SCREW 4.37	

F. 糸切れ感知関係 / Thread breakage detector mechanism / Fadenbruchfühler /
 Mécanisme du détecteur de cassure du fil / Mecanismo del sensor de cortes de hilo

REF.NO.	CODE	Q'TY	ヒンメイ	NAME OF PARTS	RMKS
1	S29468001	1	ファイハ"ユニットN	FIBER UNIT (N)	
2	S02657001	1	コード"オサエ	CORD HOLDER	
3	062300612	2	ナヘ"コ3X6	SCREW 3X6	
4	028030242	2	ハ"ネサ"カ"ネ2-3	SPRING WASHER 2-3	
5	152937001	1	サ"カ"ネ	WASHER	

G. スタッカー関係/Stacker mechanism/Anhufung/
Mecanisme de l'empileur/Mecanismo de apilador

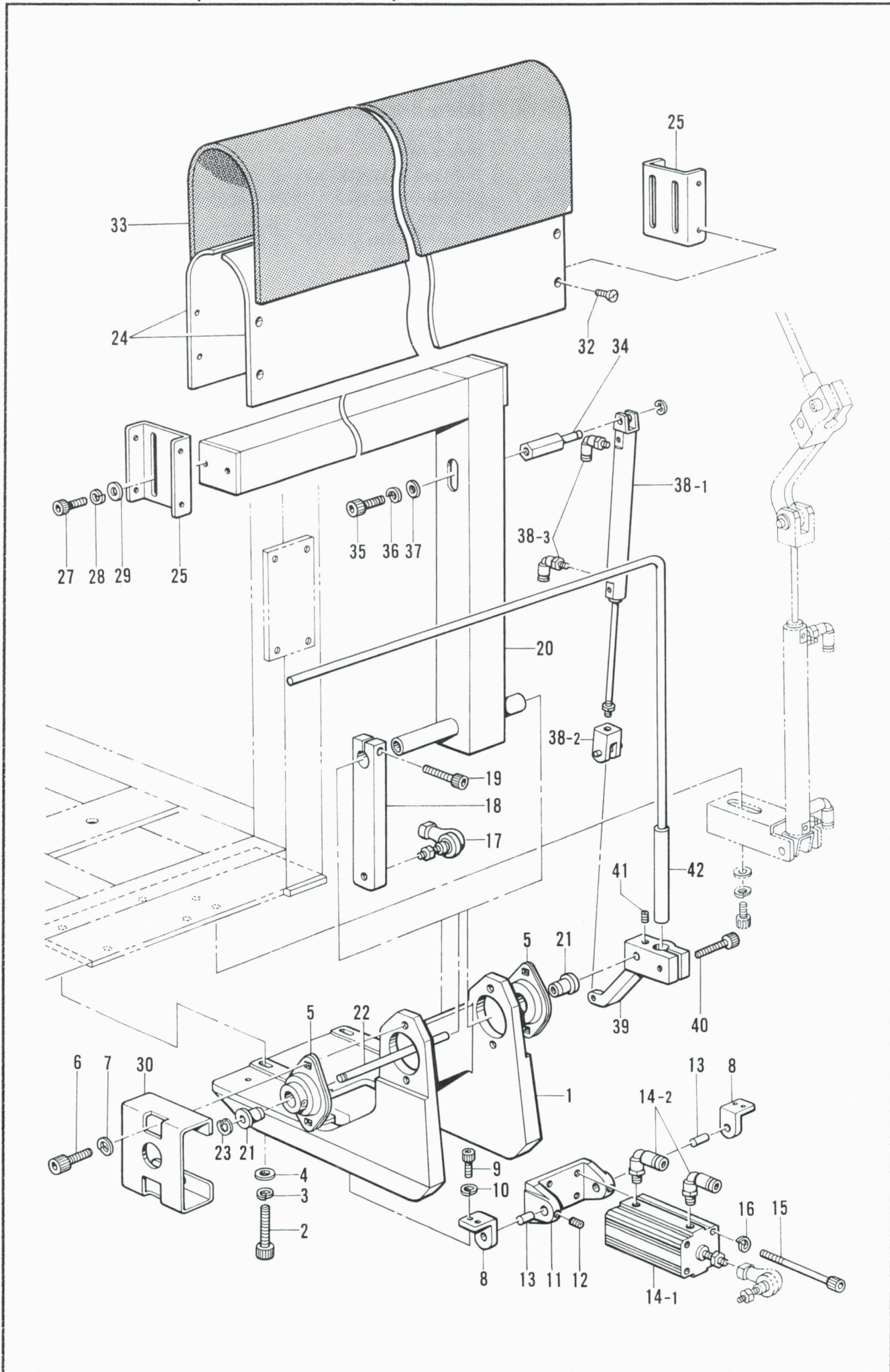

G. スタッカー関係/Stacker mechanism/Anhäufung/
Mécanisme de l'empileur/Mecanismo de apilador

REF.NO.	CODE	Q'TY	ヒンメイ	NAME OF PARTS	RMKS
<ヒョウジュンスタッカーヨウ /FOR STANDARD STACKER>					
1	S11968009	1	ベース	BASE	
2	018082522	4	アナボルト8X25	BOLT 8X25	
3	028080242	4	ハネサカネ2-8	SPRING WASHER 2-8	
4	025080232	4	ヒラサカネチユウ8	PLAIN WASHER 8	
5	S11969000	2	フランシカタクニツト2	FRANGE TYPE UNIT 2	
6	018081422	4	アナボルト8X14	BOLT 8X14	
7	028080242	4	ハネサカネ2-8	SPRING WASHER 2-8	
8	S11970009	2	ヒンジ	HINGE	
9	018061422	4	アナボルト6X14	BOLT 6X14	
10	028060242	4	ハネサカネ2-6	SPRING WASHER 2-6	
11	S11971009	1	ナツクル	KNUCKLE	
12	014400522	2	アナクホミ4X5	SET SCREW 4X5	
13	S11972001	2	クレビスピン	CLEVIS PIN	
14	S11973000	1	シリンダ-32X80クミ	CYLINDER 32X80 ASSEMBLY	
14-1	S11974000	1	シリンダ-32X80	CYLINDER 32X80	
14-2	S04909000	2	エルボユニオン	ELBOW UNION	
15	S11975000	4	CQ2ボルトM5X135	CQ2 BOLT M5X135	
16	028050242	4	ハネサカネ2-5	SPRING WASHER 2-5	
17	S11976000	1	リンクボール10	LINK BALL 10	
18	S11977001	1	レバー(3)	LEVER 3	
19	018062522	1	アナボルト6X25	BOLT 6X25	
20	S25055009	1	フレームJ	FRAME (J)	
21	S11979000	2	フランシフシユ1220	FLANGE BUSH 1220	
22	S11980001	1	レバーシャフト	LEVER SHAFT	
23	048120142	1	トメワシクヨウC12	STOP RING C12	
24	S24756000	2	スタッカータイ	STACKER BASE	
25	S24757001	2	スタッカーブラケットJ	STACKER BRACKET (J)	
27	018501022	4	アナボルト5X10	BOLT 5X10	
28	028050242	4	ハネサカネ2-5	SPRING WASHER 2-5	
29	025050232	4	ヒラサカネチユウ5	PLAIN WASHER 5	
30	S24758001	1	ベアリングカバー	BEARING COVER	
32	004400702	8	ネジ4X7	SCREW 4X7	
33	S24759000	1	スタッカーテーブルゴム	STACKER TABLE RUBBER	
34	S11985001	1	クレビスシャフト1	CLEVIS SHAFT 1	
35	018081222	1	アナボルト8X12	BOLT 8X12	
36	028080242	1	ハネサカネ2-8	SPRING WASHER 2-8	
37	025080232	1	ヒラサカネチユウ8	PLAIN WASHER 8	
38	S11986000	1	シリンダ-20X150Cクミ	CYLINDER 20X150 (C) ASSEMBLY	
38-1	S11987000	1	シリンダ-20X150C	CYLINDER 20X150 (C)	
38-2	S11988000	1	ヤマナツクルシヨイント2	KNUCKLE JOINT 2	
38-3	S11426000	2	エルボユニオン4M5	ELBOW UNION 4M5	
39	S11989009	1	レバー(1)	LEVER 1	
40	018062522	1	アナボルト6X25	BOLT 6X25	
41	014060632	1	アナトメ6X6クホミ	SET SCREW 6X6	
42	S11990001	1	オサエ棒	PRESSER BAR	

G. スタッカー関係/Stacker mechanism/Anhäufung/
 Mécanisme de l'empileur/Mecanismo de apilador

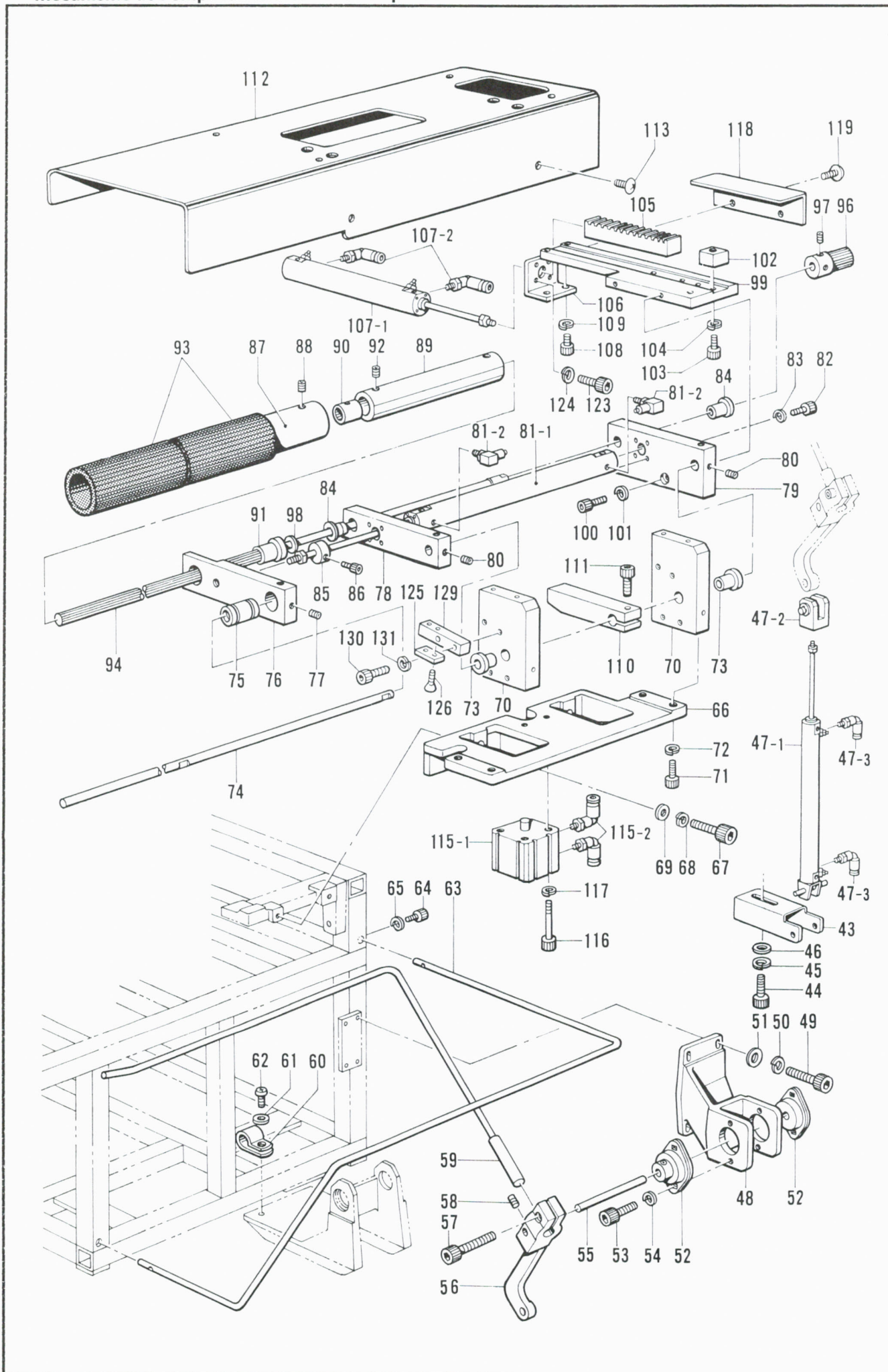

G. スタッカー関係/Stacker mechanism/Anhäufung/
Mécánisme de l'empileur/Mecanismo de apilador

REF.NO.	CODE	Q'TY	ヒンメイ	NAME OF PARTS	RMKS
<ヒョウジュンスタッカー, ワーキングスタッカーヨウ /FOR STANDARD STACKER AND WORKING STACKER>					
43	S11991001	1	スタツカーウケカナク	STACKER SUPPORT METAL FITTING	
44	018061422	2	アナボ"ルト6X14	BOLT 6X14	
45	028060242	2	ハ"ネサ"カ"ネ2-6	SPRING WASHER 2-6	
46	025060232	2	ヒラサ"カ"ネチユウ6	PLAIN WASHER 6	
47	S11992000	1	シリンダ"-25X200クミ	CYLINDER 25X200 (C) ASSEMBLY	
47-1	S11993000	1	シリンダ"-25X200C	CYLINDER 25X200 (C)	
47-2	S11994000	1	2ヤマナツクルシ"ヨイント1	KNUCKLE JOINT 1	
47-3	S11426000	2	エルボ"ユニオン4M5	ELBOW UNION 4M5	
48	S11995009	1	ヘ"ース(2)	BASE 2	
49	018062022	4	アナボ"ルト6X20	BOLT 6X20	
50	028060242	4	ハ"ネサ"カ"ネ2-6	SPRING WASHER 2-6	
51	025060232	4	ヒラサ"カ"ネチユウ6	PLAIN WASHER 6	
52	S11996000	2	フランシ"カ"タユニット	FLANGE TYPE UNIT 1	
53	018061422	4	アナボ"ルト6X14	BOLT 6X14	
54	028060242	4	ハ"ネサ"カ"ネ2-6	SPRING WASHER 2-6	
55	S11997001	1	シャフト	SHAFT	
56	S11998009	1	レハ"ー(2)	LEVER 2	
57	018062522	1	アナボ"ルト6X25	BOLT 6X25	
58	014060632	1	アナトメ6X6クホ"ミ	SET SCREW 6X6	
59	S24560001	1	キシ"ハライホ"ウ	CLOTH WIPER SHAFT	
60	525907000	1	コート"ホルタ"9N	CORD HOLDER (9N)	
61	025040233	1	ヒラサ"カ"ネチユウ4	PLAIN WASHER 4	
62	062400806	1	ナヘ"コ4X8	SCREW M4X8	
63	S24760009	1	スタツカーガ"ート"	STACKER GUARD	
64	018501222	4	アナボ"ルト5X12	BOLT 5X12	
65	028050242	4	ハ"ネサ"カ"ネ2-5	SPRING WASHER 2-5	
67	018062022	2	アナボ"ルト6X20	BOLT 6X20	
68	028060242	2	ハ"ネサ"カ"ネ2-6	SPRING WASHER 2-6	
69	025060232	2	ヒラサ"カ"ネチユウ6	PLAIN WASHER 6	
73	S12002000	2	フランシ"フ"ツシユ1012	FLANGE BUSH 1012	
74	S12003000	1	LMシャフト	LM SHAFT	
75	S12004000	1	リニアフ"ツシユ	LINEAR BUSH	
76	S12005001	1	タイフ"レート	TIE PLATE	
77	014400522	2	アナクホ"ミ4X5	SET SCREW 4X5	
78	S12006000	1	エンド"フ"レートB	END PLATE (B)	
79	S12007000	1	エンド"フ"レートA	END PLATE (A)	
80	014400522	4	アナクホ"ミ4X5	SET SCREW 4X5	
81	S12008000	1	シリンダ"-20X150クミ	CYLINDER 20X150 ASSEMBLY	
81-1	S12009000	1	シリンダ"-20X150	CYLINDER 20X150	
81-2	S12150000	2	ホ"ースエルボ"M-5HL-4	TUBE ELBOW (M-5HL-4)	
82	018401622	8	アナボ"ルト4X16	BOLT 4X16	
83	028040242	8	ハ"ネサ"カ"ネ2-4	SPRING WASHER 2-4	
84	S12010000	2	フランシ"フ"ツシユ1010	FLANGE BUSH 1010	
85	S12011001	1	ストツハ"ー	STOPPER	
86	018401022	1	アナボ"ルト4X10	BOLT 4X10	
87	S12012000	1	ローラ"ー	ROLLER	
88	014500522	2	アナトメネシ"5クホ"ミ	SET SCREW 5	
89	S12013000	1	ローラ"ーササエ	ROLLER SUPPORT	
90	S12014000	1	スプ"ラインナツト1	SPLINE NUT 1	
91	S12015000	1	スプ"ラインナツト2	SPLINE NUT 2	
92	014500522	4	アナトメネシ"5クホ"ミ	SET SCREW 5	
93	S20789000	2	スリ"ーフ"ロール	SLEEVE ROLL	
94	S17718000	1	スプ"ラインシ"ク	SPLINE SHAFT	
96	S12019001	1	キ"ヤ	GEAR	
97	014500522	2	アナトメネシ"5クホ"ミ	SET SCREW 5	
98	S09027001	1	ヒラサ"カ"ネシユウ10	PLAIN WASHER 10	
99	S12020001	1	ローラ"ーガ"イト"	ROLLER GUIDE	
100	018401622	1	アナボ"ルト4X16	BOLT 4X16	
101	028040242	2	ハ"ネサ"カ"ネ2-4	SPRING WASHER 2-4	
102	S12021001	1	ラツクストツハ"ー	RACK STOPPER	

G. スタッカー関係 / Stacker mechanism / Anhäufung /
 Mécanisme de l'empileur / Mecanismo de apilador

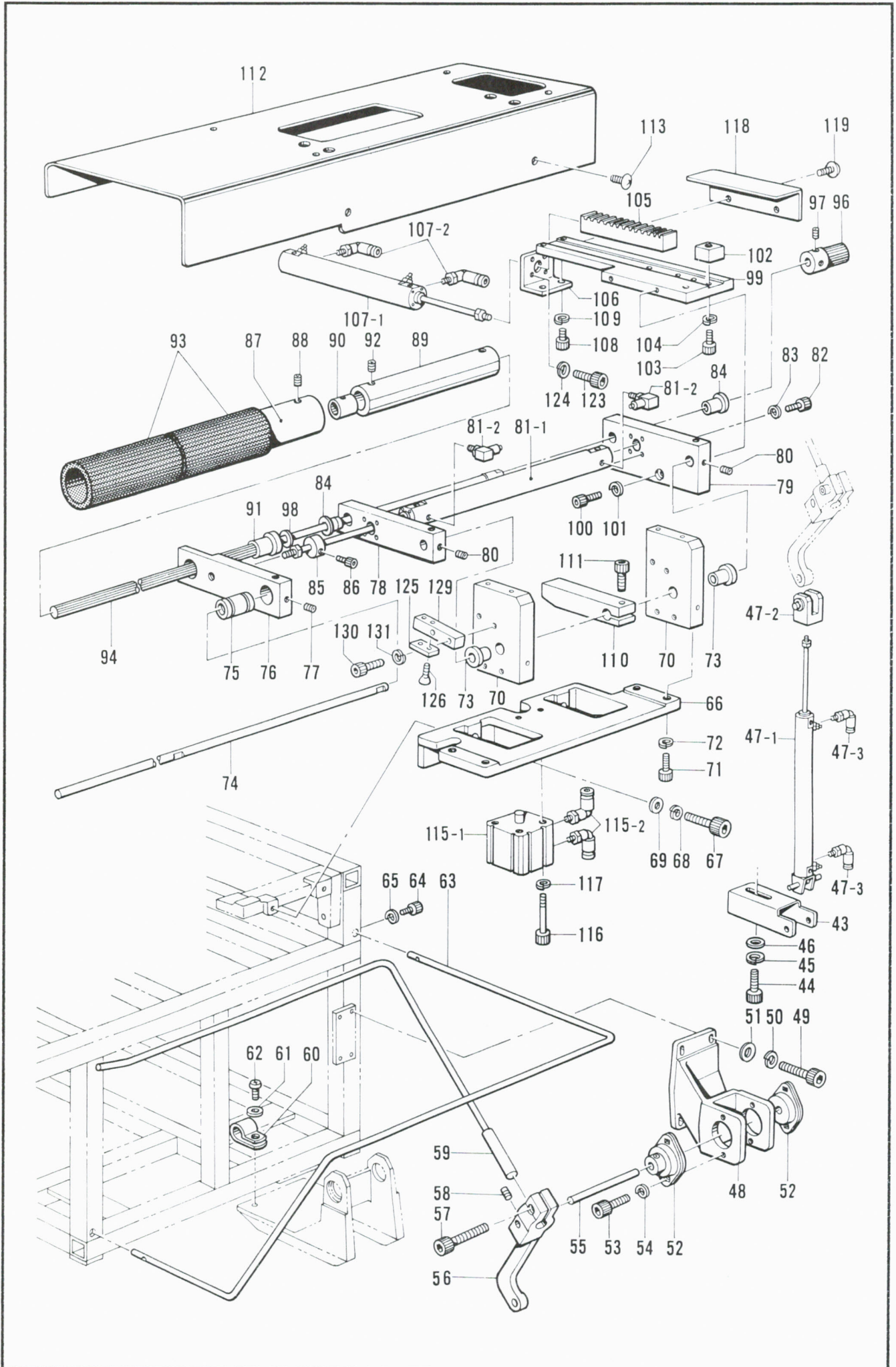

G. スタッカー関係/Stacker mechanism/Anhäufung/
 Mécanisme de l'empileur/Mecanismo de apilador

REF.NO.	CODE	Q'TY	ヒンメイ	NAME OF PARTS	RMKS
103	018401622	1	アナボルト4X16	BOLT 4X16	
104	028040242	1	ハネサカネ2-4	SPRING WASHER 2-4	
105	S12022001	1	ラック	RACK	
106	S12023001	1	ローラーブラケット	ROLLER BRACKET	
107	S12024000	1	シリンダ-20X95クミ	CYLINDER 20X95 ASSEMBLY	
107-1	S12025000	1	シリンダ-20X95	CYLINDER 20X95	
107-2	S11426000	2	エルボユニオン4M5	ELBOW UNION 4M5	
108	018401022	7	アナボルト4X10	BOLT 4X10	
109	028040242	6	ハネサカネ2-4	SPRING WASHER 2-4	
110	S23398001	1	ローラレハ-	ROLLER LEVER	
111	018501622	1	アナボルト5X16	BOLT 5X16	
115	S12030000	1	シリンダ-20X15クミ	CYLINDER 20X15 ASSEMBLY	
115-1	S12031000	1	シリンダ-20X15	CYLINDER 20X15	
115-2	S11426000	2	エルボユニオン4M5	ELBOW UNION 4M5	
116	S12276000	2	CQ2ボルトM5X35	CQ2 BOLT M5X35	
117	028050243	2	ハネサカネ2-5	SPRING WASHER 2-5	
118	S12033009	1	ローラカハ-A	ROLLER COVER (A)	
119	008400604	2	+トラスコ4X6	SCREW 4X6	
123	018501022	4	アナボルト5X10	BOLT 5X10	
124	028050242	4	ハネサカネ2-5	SPRING WASHER 2-5	
125	S23394000	2	ローラストツハ°	ROLLER STOPPER	
126	004400804	4	+サラネシ4X8	SCREW 4X8	
129	S23395001	2	ローラストツハ°-ササエ	ROLLER STOPPER SUPPORT	
130	018502022	4	アナボルト5X20	BOLT 5X20	
131	028050242	4	ハネサカネ2-5	SPRING WASHER 2-5	
<キョウツウブヒン /FOR COMMON PARTS>					
66	S12000009	1	ローラベース	ROLLER BASE	
70	S23392001	2	ローラシャクササエ	ROLLER SHAFT SUPPORT	
71	018401222	4	アナボルト4X12	BOLT 4X12	
72	028040242	4	ハネサカネ2-4	SPRING WASHER 2-4	
112	S12029109	1	ローラカハ-B	ROLLER COVER (B)	
113	008400604	6	+トラスコ4X6	SCREW 4X6	

G. スタッカー関係 / Stacker mechanism / Anhäufung /
 Mécanisme de l'empileur / Mecanismo de apilador

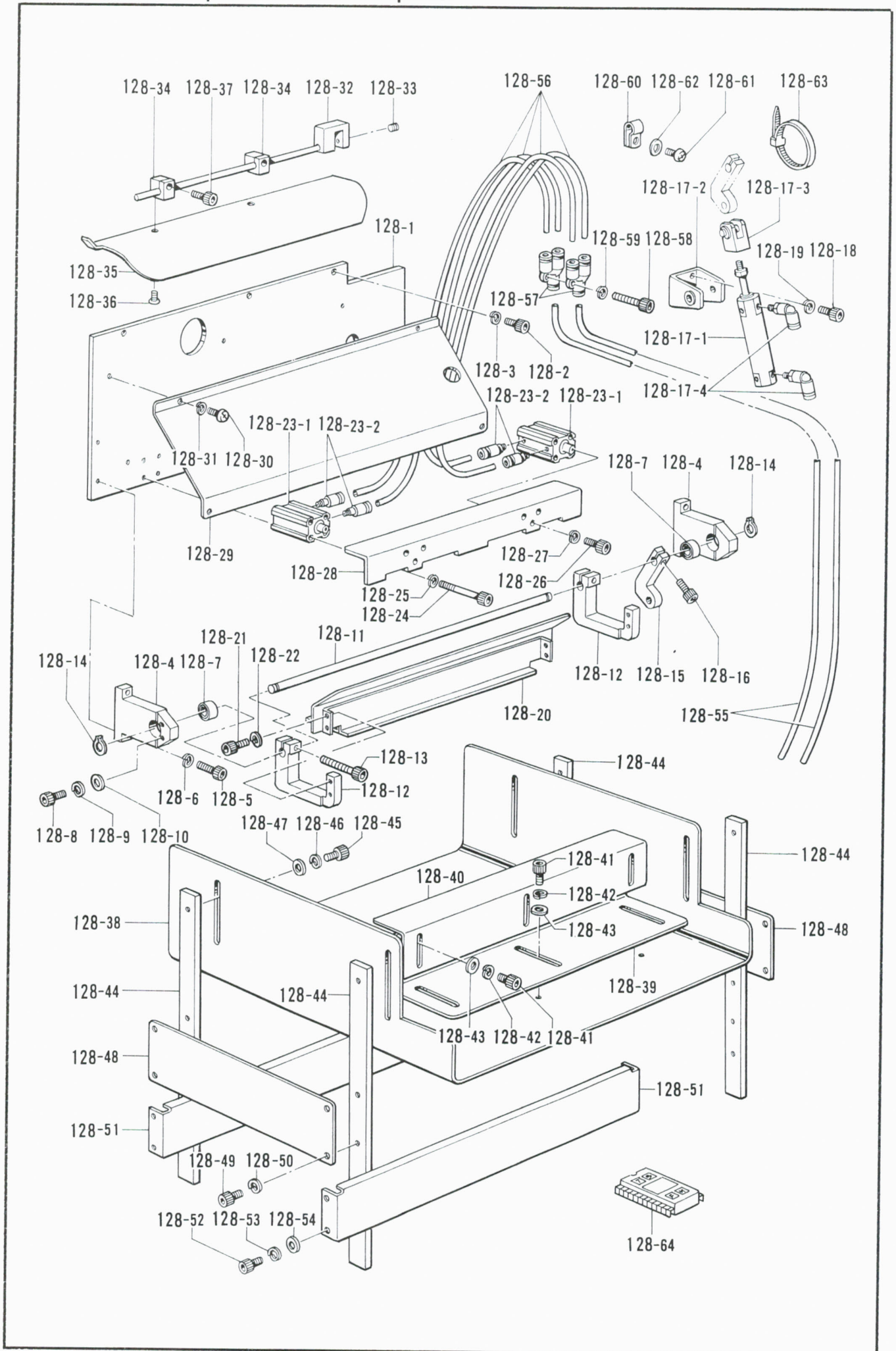

G. スタッカー関係/Stacker mechanism/Anhäufung/
 Mécanisme de l'empileur/Mecanismo de apilador

REF.NO.	CODE	Q'TY	ヒンメイ	NAME OF PARTS	RMKS
<コクナイヨウ.オプション>					
128	*	1	スタッカー(WORK)クミ	-----	
128-1	S14462009	1	トリツケイタ	-----	
128-2	018401022	6	アナホ"ルト4X10	-----	
128-3	028040242	6	ハ"ネサ"カ"ネ2-4	-----	
128-4	S14463009	2	ヘ"アリング"ササエ	-----	
128-5	018501622	4	アナホ"ルト5X16	-----	
128-6	028050242	4	ハ"ネサ"カ"ネ2-5	-----	
128-7	S12078000	2	フカミソ"タマシ"クウケ2	-----	
128-8	018400832	4	アナホ"ルト4X8	-----	
128-9	028040242	4	ハ"ネサ"カ"ネ2-4	-----	
128-10	025040232	4	ヒラサ"カ"ネチユウ4	-----	
128-11	S14464001	1	LMシャフト12	-----	
128-12	S14465009	2	レハ"ーB	-----	
128-13	018502022	2	アナホ"ルト5X20	-----	
128-14	048120142	2	トメワシ"クヨウC12	-----	
128-15	S14466001	1	レハ"ーA	-----	
128-16	018502022	1	アナホ"ルト5X20	-----	
128-17	S14468000	1	シリンタ"-25X70クミ	-----	
128-17-1	S14469000	1	シリンタ"-25X70	-----	
128-17-2	S12139000	1	ヨウト"ウウケカナク"1	-----	
128-17-3	S11994000	1	2ヤマナツクルシ"ヨイント1	-----	
128-17-4	S11426000	2	エルホ"ユニオン4M5	-----	
128-18	018500822	4	アナホ"ルト5X8	-----	
128-19	028050242	4	ハ"ネサ"カ"ネ2-5	-----	
128-20	S14470000	1	スヘ"リイタ	-----	
128-21	018500822	4	アナホ"ルト5X8	-----	
128-22	028050242	4	ハ"ネサ"カ"ネ2-5	-----	
128-23	S14471000	2	シリンタ"-20X40クミ	-----	
128-23-1	S14472000	2	ウスカ"タシリンタ"20X40	-----	
128-23-2	S04905000	4	ハーフユニオン	-----	
128-24	S14473000	8	CQ2ホ"ルトM5X60	-----	
128-25	028050243	16	ハ"ネサ"カ"ネ2-5	-----	
128-26	018501622	2	アナホ"ルト5X16	-----	
128-27	028050242	2	ハ"ネサ"カ"ネ2-5	-----	
128-28	S14475009	1	プレスイタ	-----	
128-29	S14477000	1	スヘ"リイタA	-----	
128-30	062400806	5	ナヘ"コ4X8	-----	
128-31	028040243	5	ハ"ネサ"カ"ネ2-4	-----	
128-32	S14478001	1	カ"イト"イタササエ	-----	
128-33	014500522	2	アナトメネシ"5クホ"ミ	-----	
128-34	S14479001	2	カ"イト"イタコテイ	-----	
128-35	S14480000	1	カ"イト"イタ	-----	
128-36	004400804	2	+ サラネシ"4X8	-----	
128-37	018401622	2	アナホ"ルト4X16	-----	
128-38	S14481009	1	ミゴ"ロウケ	-----	
128-39	S14482009	1	マクラシタ	-----	
128-40	S14483009	1	マクラウエ	-----	
128-41	018400832	6	アナホ"ルト4X8	-----	
128-42	028040243	6	ハ"ネサ"カ"ネ2-4	-----	
128-43	025040233	6	ヒラサ"カ"ネチユウ4	-----	
128-44	S14484009	4	スタント"	-----	
128-45	018501022	4	アナホ"ルト5X10	-----	
128-46	028050242	4	ハ"ネサ"カ"ネ2-5	-----	
128-47	025050232	4	ヒラサ"カ"ネチユウ-5	-----	
128-48	S14485009	2	レンケツイタ	-----	
128-49	018501022	8	アナホ"ルト5X10	-----	
128-50	028050242	8	ハ"ネサ"カ"ネ2-5	-----	
128-51	S14486009	2	コテイイタ	-----	
128-52	018501022	8	アナホ"ルト5X10	-----	
128-53	028050242	8	ハ"ネサ"カ"ネ2-5	-----	
128-54	025050232	8	ヒラサ"カ"ネチユウ-5	-----	

G. スタッカー関係/Stacker mechanism/Anhäufung/
 Mécanisme de l'empileur/Mecanismo de apilador

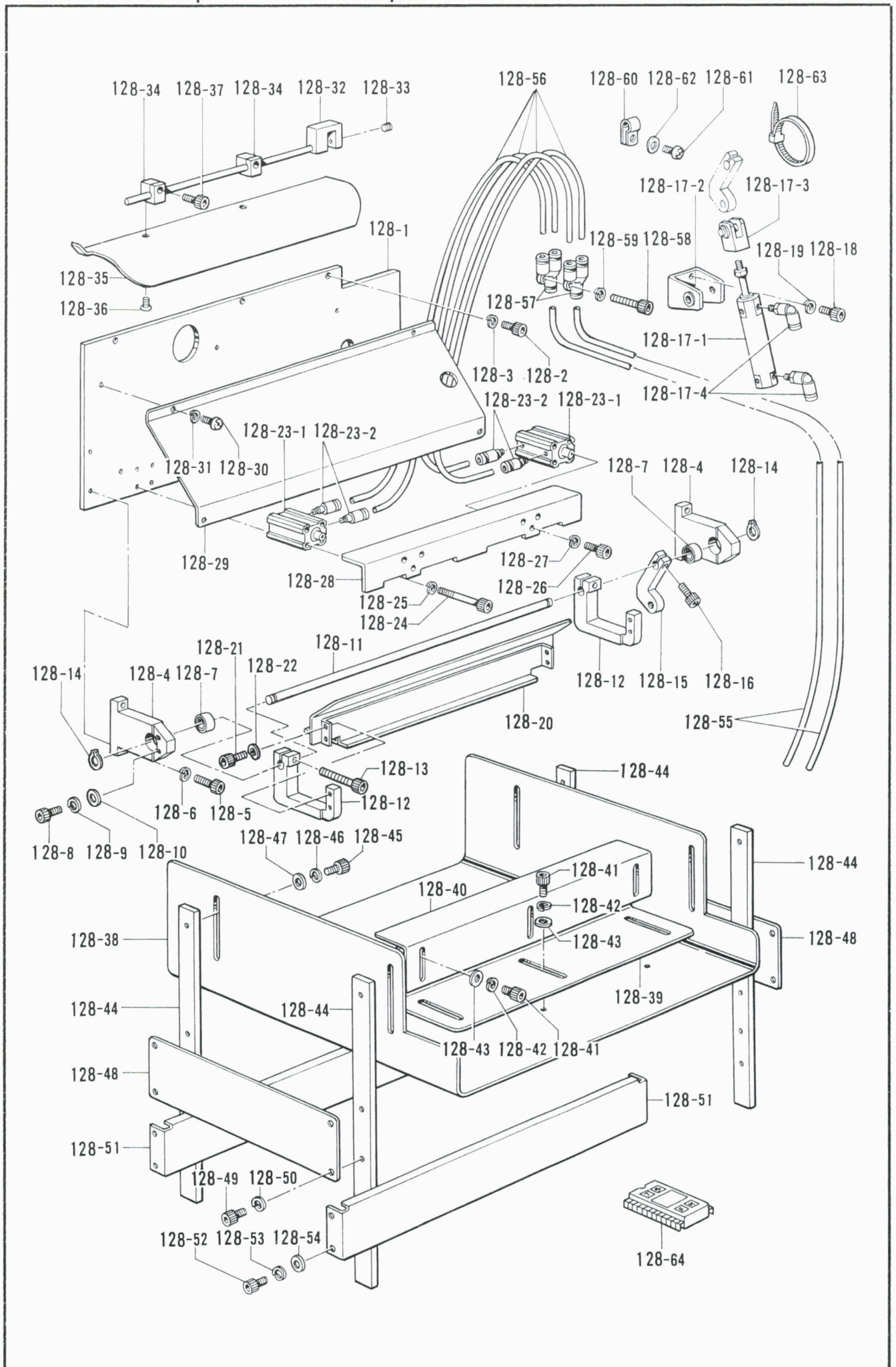

G. スタッカー関係/Stacker mechanism/Anhäufung/
 Mécanisme de l'empileur/Mecanismo de apilador

REF.NO.	CODE	Q'TY	ヒンメイ	NAME OF PARTS	RMKS
128-55	S12195000	2	エア-ホ-ス4X2.5-19	-----	
128-56	S12183000	4	エア-ホ-ス4X2.5--7	-----	
128-57	S12104000	2	ユニオンワイ4	-----	
128-58	018402522	1	アナホルト4X25	-----	
128-59	028040242	1	ハ"ネサ"カ"ネ2-4	-----	
128-60	525664000	2	コート"ホルタ"6N	-----	
128-61	062400806	2	ナヘ"コ4X8	-----	
128-62	025040233	2	ヒラサ"カ"ネチユウ4	-----	
128-63	S04159000	3	ハ"ント"1M	-----	
128-64	S24761000	1	PROM760-2ワーク	-----	

H. 駆動側・送り関係 / Drive, feed mechanism / Transportvorrichtung /
 Mécanisme d'alimentation, entraînement / Mecanismo de alimentación, mando

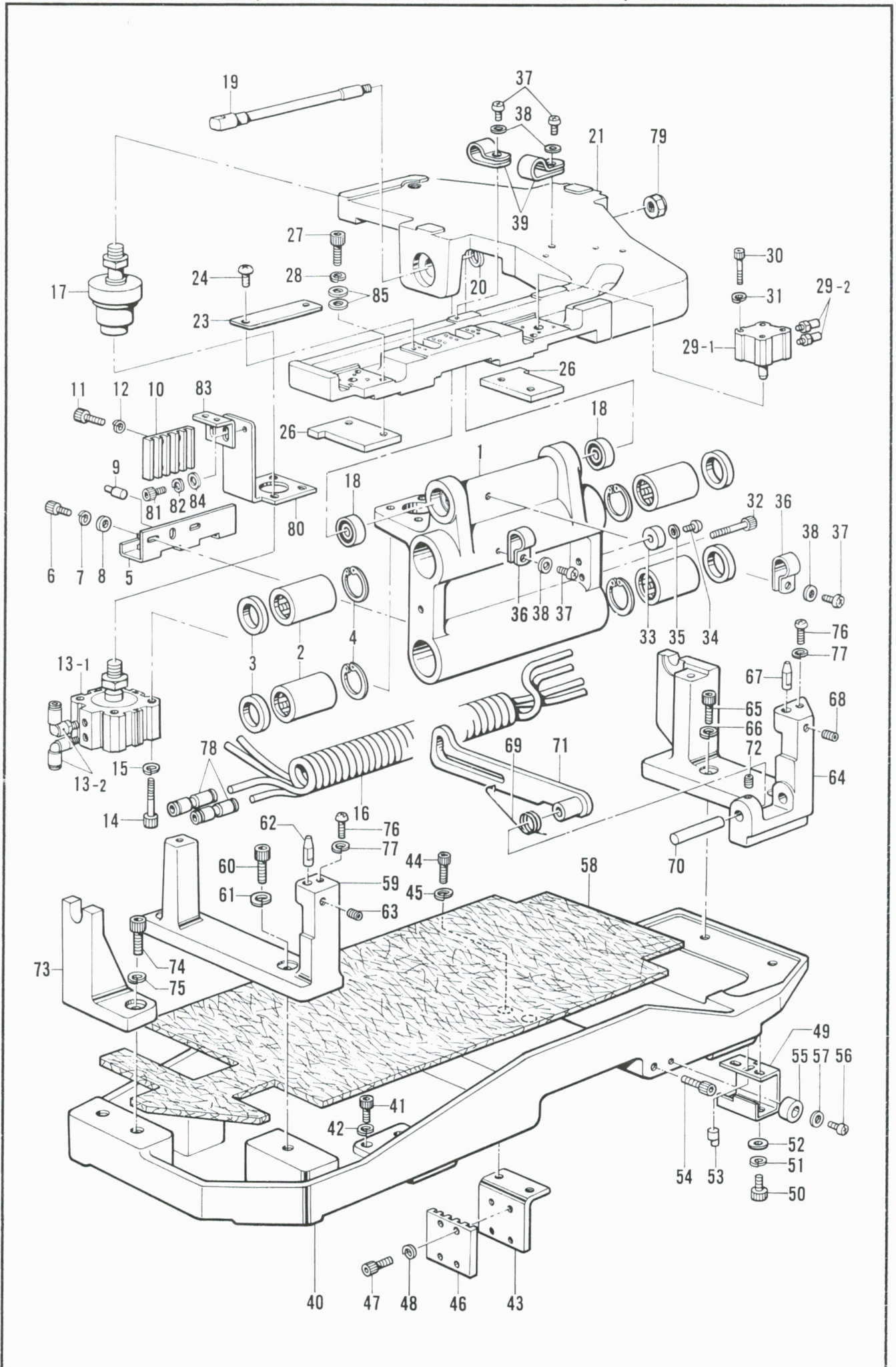

H. 駆動側・送り関係 / Drive, feed mechanism / Transportvorrichtung /
 Mécanisme d'alimentation, entraînement / Mecanismo de alimentación, mando

REF.NO.	CODE	Q'TY	ヒンメイ	NAME OF PARTS	RMKS
1	S17719009	1	オサエササエ	PRESSER SUPPORT	
2	S12035000	4	リニアボールベアリング	LINEAR BALL BEARING	
3	S12036000	4	クミアワセシール	COMBINATION SEAL	
4	048350242	4	トメフアナヨウC35	STOP RING C35	
5	S17706001	1	スリットB	SLIT (B)	
6	018400832	2	アナボルト4X8	BOLT 4X8	
7	028040242	2	ハネサカネ2-4	SPRING WASHER 2-4	
8	025040232	2	ヒラサカネチユウ4	PLAIN WASHER 4	
9	S12038001	1	スリットピン	PIN	
10	S12039001	1	ベルトホシイタB	BELT HOLD PLATE (B)	
11	018501622	4	アナボルト5X16	BOLT 5X16	
12	028050242	4	ハネサカネ2-5	SPRING WASHER 2-5	
13	S17725000	1	シリンダ-40X5クミ	CYLINDER 40X5 ASSEMBLY	
13-1	S17726000	1	シリンダ-40X5	CYLINDER 40X5	
13-2	S04909000	2	エルボユニオン	ELBOW UNION	
14	S19553000	4	CQ2ボルトM5X40	CQ2 BOLT M5X40	
15	028050243	4	ハネサカネ2-5	SPRING WASHER 2-5	
16	S04907000	1	スパイラルホース	SPIRAL TUBE	
17	S12044000	1	フローティングジョイント	FLOATING JOINT	
18	S12045000	2	アンギユラタマシクウケ1	ANGULAR BALL BEARING 1	
19	S15538001	1	ポケットオサエシク	POCKET PRESSER SHAFT	
20	S15539001	1	カラ-2-15	COLLAR 2-15	
21	S17716009	1	オサエ	PRESSER FOOT	
23	S17717009	1	オサエカバー	COVER	
24	008400604	2	+トラスコ4X6	SCREW 4X6	
26	S12050001	2	ブロックササエ	BLOCK SUPPORT	
27	018502022	4	アナボルト5X20	BOLT 5X20	
28	028050242	4	ハネサカネ2-5	SPRING WASHER 2-5	
29	S12051000	2	ロックシリンダ-クミA	LOCK CYLINDER ASSEMBLY (A)	
29-1	S12052000	2	ロックシリンダ-	LOCK CYLINDER	
29-2	S11433000	4	ホースニツプル4M5	HOSE NIPPLE 4M5	
30	S12053000	8	CQ2ボルトM3X25	CQ2 BOLT M3X25	
31	028030243	8	ハネサカネ2-3	SPRING WASHER 2-3	
32	S19553000	1	CQ2ボルトM5X40	CQ2 BOLT M5X40	
33	S12054000	2	クッション	CUSHION	
34	062400806	2	ナヘコ4X8	SCREW M4X8	
35	025040233	2	ヒラサカネチユウ4	PLAIN WASHER 4	
36	149287000	2	ナイロンクランプ7N	NYLON CLAMP (7N)	
37	062400806	4	ナヘコ4X8	SCREW M4X8	
38	025040233	4	ヒラサカネチユウ4	PLAIN WASHER 4	
39	525907000	2	コードホルダ9N	CORD HOLDER (9N)	
40	S24762001	1	ミシンササエ	HEAD SUPPORT	
41	018401622	16	アナボルト4X16	BOLT 4X16	
42	028040242	16	ハネサカネ2-4	SPRING WASHER 2-4	
43	S12056001	1	ベルトホシイタA	BELT HOLD PLATE (A)	
44	018502022	2	アナボルト5X20	BOLT 5X20	
45	028050242	2	ハネサカネ2-5	SPRING WASHER 2-5	
46	S12039001	1	ベルトホシイタB	BELT HOLD PLATE (B)	
47	018501622	4	アナボルト5X16	BOLT 5X16	
48	028050242	4	ハネサカネ2-5	SPRING WASHER 2-5	
49	S24832001	1	スリットC	SLIT (C)	
50	018400832	2	アナボルト4X8	BOLT 4X8	
51	028040242	2	ハネサカネ2-4	SPRING WASHER 2-4	
52	025040232	2	ヒラサカネチユウ4	PLAIN WASHER 4	
53	S12038001	1	スリットピン	PIN	
54	018502522	1	アナボルト5X25	BOLT 5X25	
55	S12054000	2	クッション	CUSHION	
56	062400806	2	ナヘコ4X8	SCREW M4X8	
57	025040232	2	ヒラサカネチユウ4	PLAIN WASHER 4	
58	S24763000	1	ミシンササエフェルト	FELT	
59	S24764001	1	ミシンウケタイル	HEAD SUPPORT BASE (L)	
60	018082022	2	アナボルト8X20	BOLT 8X20	

H. 駆動側・送り関係/Drive, feed mechanism/Transportvorrichtung/
 Mécanisme d'alimentation, entraînement/Mecanismo de alimentación, mando

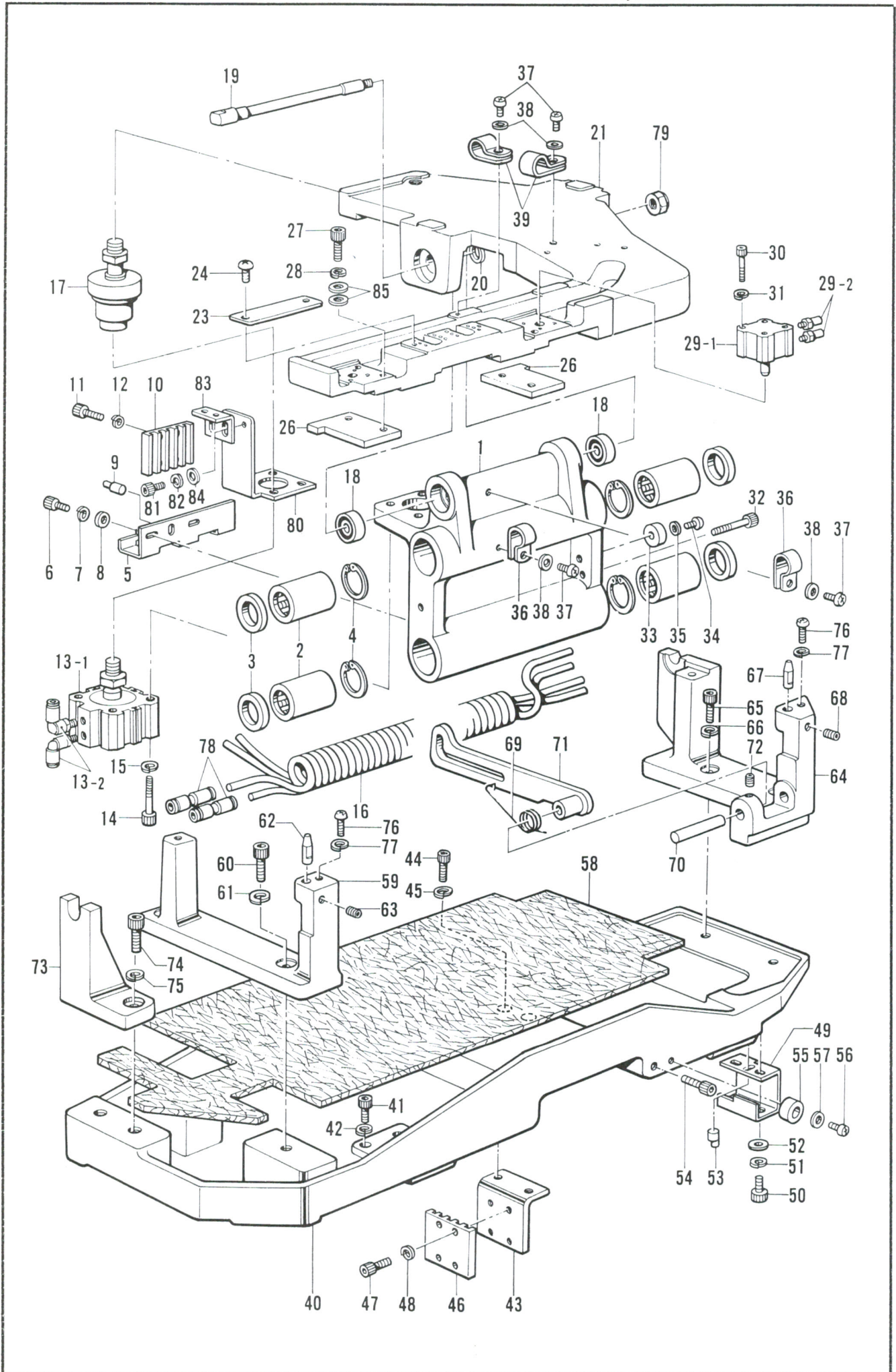

K. 折り曲げ関係 / Folding margin mechanism / Faltungsvorrichtung /
 Mécanisme de marge d'ourlet / Mecanismo de margen de plegado

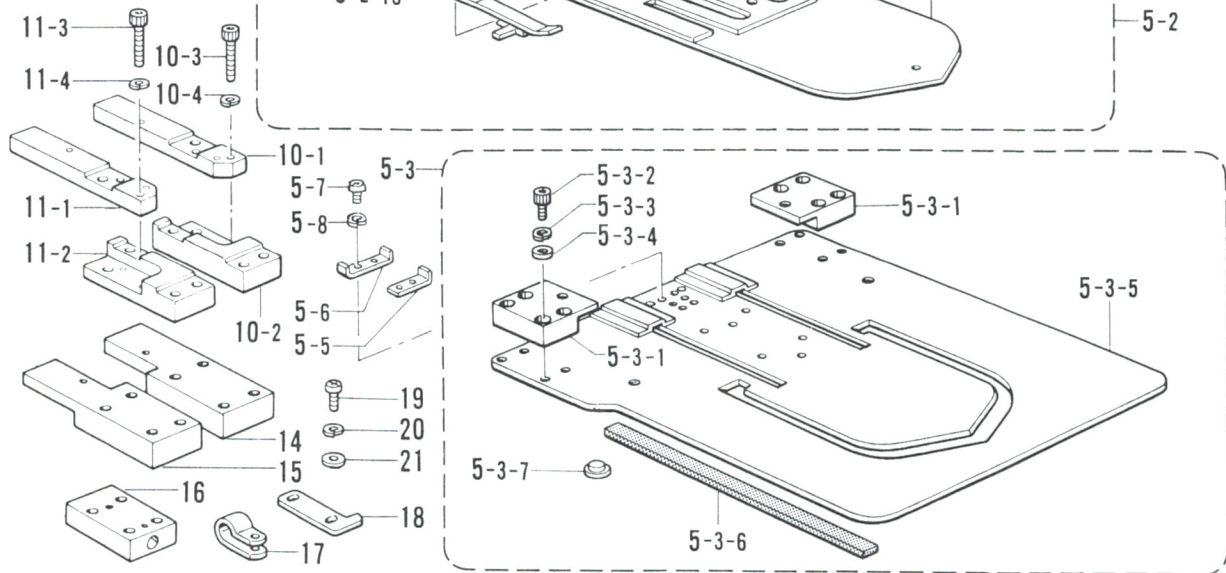
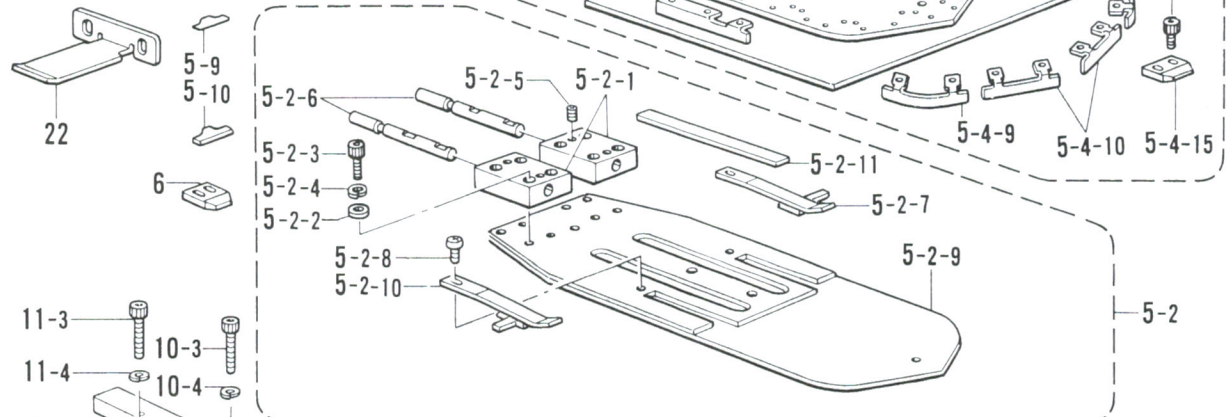
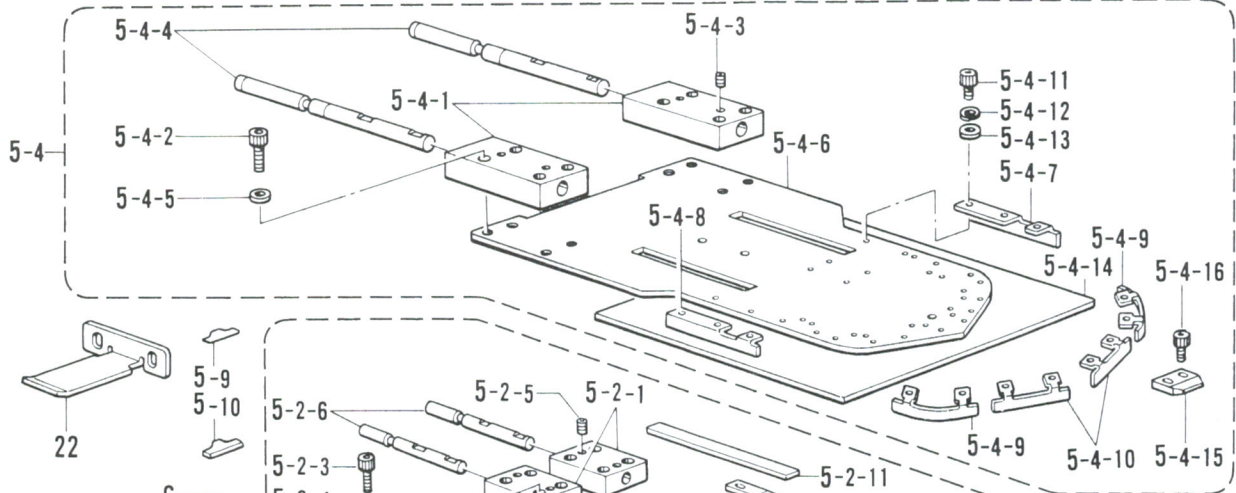
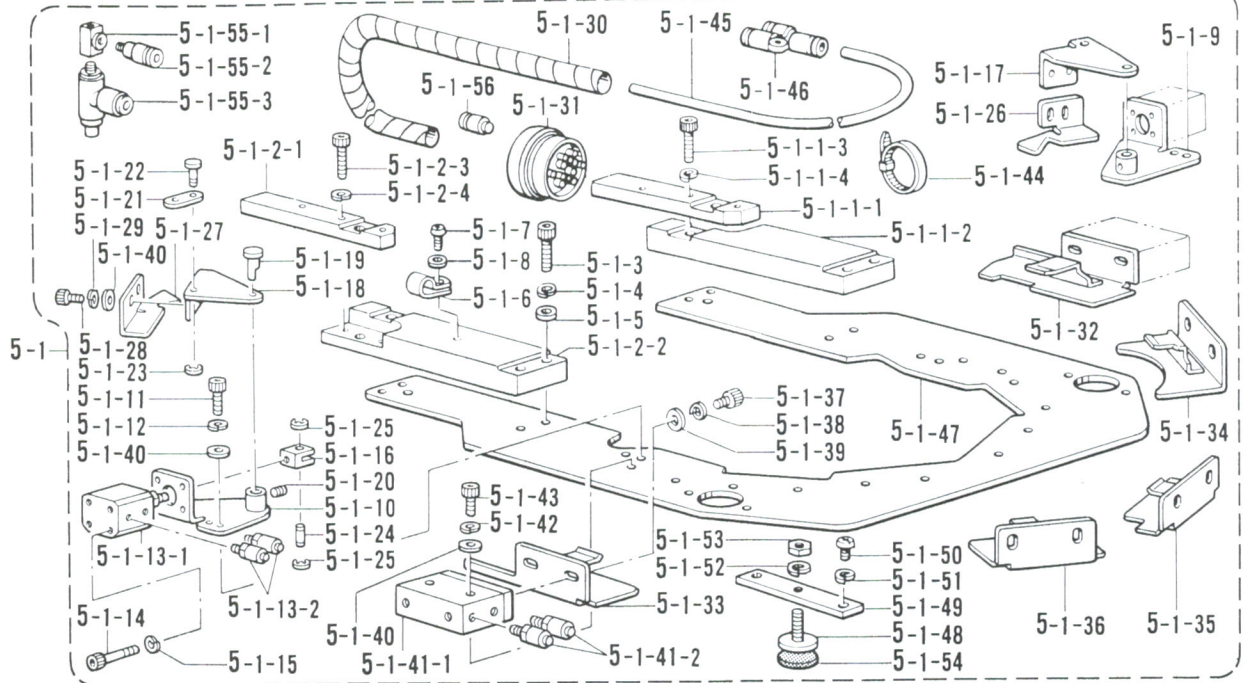

K. 折り曲げ関係 / Folding margin mechanism / Faltungsvorrichtung /
 Mécanisme de marge d'ourlet / Mecanismo de margen de plegado

REF.NO.	CODE	Q'TY	ヒンメイ	NAME OF PARTS	RMKS
5	S24833---	1	オリキクミーマル2J	FOLDING GROUP ASSEMBLY (ROUND-2J)	
5-1	S24834---	1	オリササエクミーマル2J	FOLDING CLAMP ASSEMBLY (ROUND-2J)	
5-1-1	S24886001	1	コネクタブロックSRクミ	CONNECT BLOCK (SR) ASSEMBLY	
5-1-1-1	S24456001	1	コネクタブロックSR-1	CONNECT BLOCK (SR-1)	
5-1-1-2	S24457001	1	コネクタブロックSR-2	CONNECT BLOCK (SR-2)	
5-1-1-3	018502022	2	アナホルルト5X20	BOLT 5X20	
5-1-1-4	028050242	2	ハ"ネサ"カ"ネ2-5	SPRING WASHER 2-5	
5-1-2	S24887001	1	コネクタブロックSLクミ	CONNECT BLOCK (SL) ASSEMBLY	
5-1-2-1	S24454001	1	コネクタブロックSL-1	CONNECT BLOCK (SL-1)	
5-1-2-2	S24455001	1	コネクタブロックSL-2	CONNECT BLOCK (SL-2)	
5-1-2-3	018502022	2	アナホルルト5X20	BOLT 5X20	
5-1-2-4	028050242	2	ハ"ネサ"カ"ネ2-5	SPRING WASHER 2-5	
5-1-3	018502522	8	アナホルルト5X25	BOLT 5X25	
5-1-4	028050242	8	ハ"ネサ"カ"ネ2-5	SPRING WASHER 2-5	
5-1-5	S20246001	8	ヒラサ"カ"ネタ"イ5	PLAIN WASHER 5	
5-1-6	552907000	1	コート"ホルタ"10N	CORD HOLDER (10N)	
5-1-7	062401006	1	ナヘ"コ4X10	SCREW 4X10	
5-1-8	025040233	1	ヒラサ"カ"ネチユウ4	PLAIN WASHER 4	
5-1-9	S24783001	1	メントリト"タ"イRJ	TUCKING BASE (RJ)	
5-1-10	S24784001	1	メントリト"タ"イLJ	TUCKING BASE (LJ)	
5-1-11	018400822	4	アナホルルト4X8	BOLT 4X8	
5-1-12	028040242	4	ハ"ネサ"カ"ネ2-4	SPRING WASHER 2-4	
5-1-13	S12090000	2	シリンダ"-12X10クミ	CYLINDER 12X10 ASSEMBLY	
5-1-13-1	S12091000	2	シリンダ"-12X10	CYLINDER 12X10	
5-1-13-2	S11433000	4	ホースニツプル4M5	HOSE NIPPLE 4M5	
5-1-14	S12092000	8	CQ2ホルルトM3X30	CQ2 BOLT M3X30	
5-1-15	028030243	8	ハ"ネサ"カ"ネ2-3	SPRING WASHER 2-3	
5-1-16	S12093001	2	ナツクル	KNUCKLE	
5-1-17	S24785000	1	メントリヒンシ"RJ	HINGE (RJ)	
5-1-18	S24786000	1	メントリヒンシ"LJ	HINGE (LJ)	
5-1-19	S12096001	2	ヒンシ"ヒン	PIN	
5-1-20	014400522	2	アナクホ"ミ4X5	SET SCREW 4X5	
5-1-21	S12097001	2	タイププレート	TIE PLATE	
5-1-22	S12098001	2	ピン	PIN	
5-1-23	048050342	2	トメワE5	STOP RING E5	
5-1-24	S12099001	2	ナツクルピン	PIN	
5-1-25	048050342	4	トメワE5	STOP RING E5	
5-1-26	S24787000	1	メントリイタRJ	TUCKING BLADE (RJ)	
5-1-27	S24788000	1	メントリイタLJ	TUCKING BLADE (LJ)	
5-1-28	018400632	4	アナホルルト4X6	BOLT 4X6	
5-1-29	028040242	4	ハ"ネサ"カ"ネ2-4	SPRING WASHER 2-4	
5-1-30	S12214000	1	スパイラル640L	SPIRAL 640L	
5-1-31	S12106000	1	マルチコネクタP	MULTI CONNECTOR (P)	
5-1-32	S24835---	1	オリイタR-マル2J	TUCKING BLADE (R-ROUND-2J)	
5-1-33	S24836---	1	オリイタL-マル2J	TUCKING BLADE (L-ROUND-2J)	
5-1-34	S24837---	2	オリイタS-マル2J	TUCKING BLADE (S-ROUND-2J)	
5-1-35	S24838---	1	オリイタSR-マル2J	TUCKING BLADE (SR-ROUND-2J)	
5-1-36	S24839---	1	オリイタSL-マル2J	TUCKING BLADE (SL-ROUND-2J)	
5-1-37	018500822	12	アナホルルト5X8	BOLT 5X8	
5-1-38	028050242	12	ハ"ネサ"カ"ネ2-5	SPRING WASHER 2-5	
5-1-39	S20246001	12	ヒラサ"カ"ネタ"イ5	PLAIN WASHER 5	
5-1-40	158722002	20	サ"カ"ネ4.2	WASHER 4.2	
5-1-41	S24789000	6	ツインロッド"シリンダ"-クミ	TWIN ROD CYLINDER ASSEMBLY	
5-1-41-1	S24790000	6	ツインロッド"シリンダ"-20	TWIN ROD CYLINDER 20	
5-1-41-2	S11433000	12	ホースニツプル4M5	HOSE NIPPLE 4M5	
5-1-42	028040242	12	ハ"ネサ"カ"ネ2-4	SPRING WASHER 2-4	
5-1-43	018403022	12	アナホルルト4X30	BOLT 4X30	
5-1-44	S04159000	4	バンド"1M	BAND 1M	
5-1-45	S12205000	1	エアホース4X2.5-29	AIR TUBE 4X2.5-29 (L=7500)	
5-1-46	S12104000	10	ユニオンワイ4	UNION-Y 4	
5-1-47	S24839---	1	オリイタSL-マル2J	TUCKING BLADE (SL-ROUND-2J)	
5-1-48	S12291001	2	アジ"ヤストネジ"	ADJUST SCREW	

K. 折り曲げ関係 / Folding margin mechanism / Faltungsvorrichtung /
 Mécanisme de marge d'ourlet / Mecanismo de margen de plegado

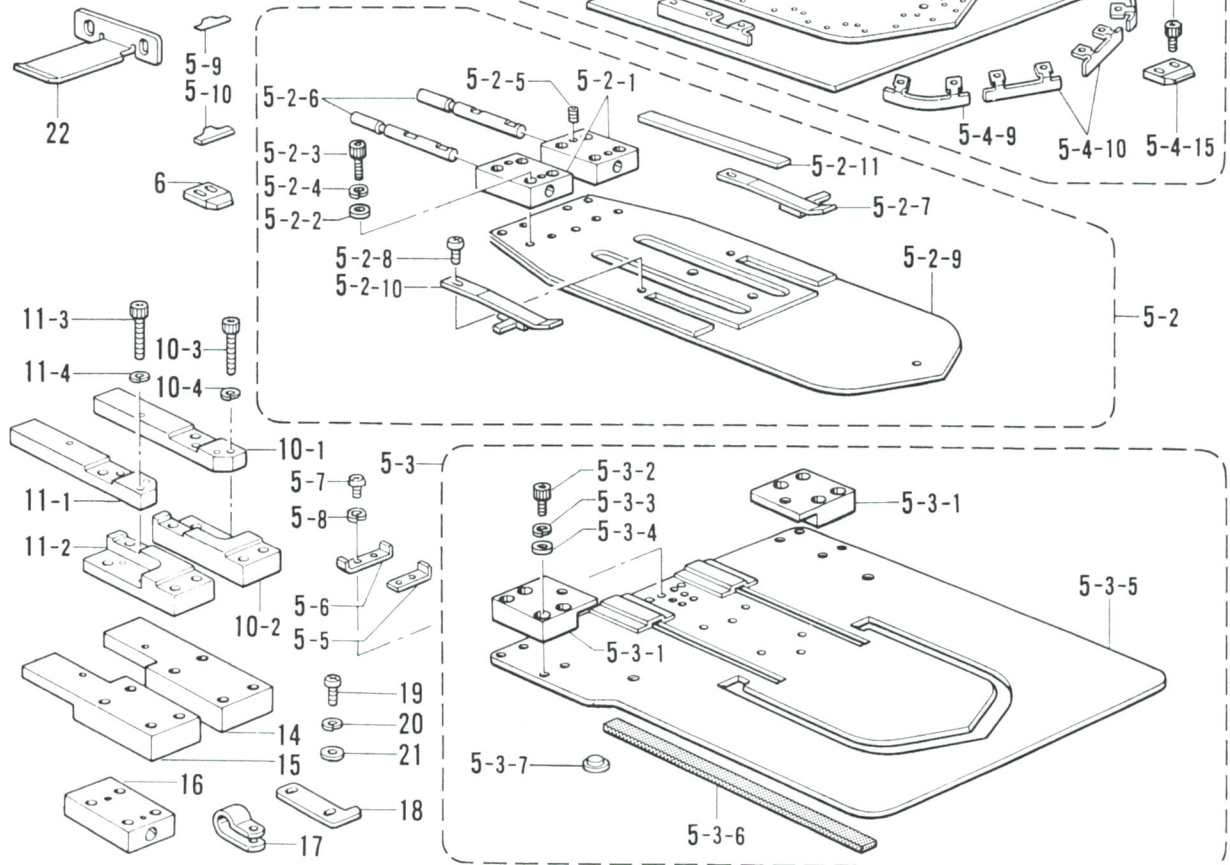
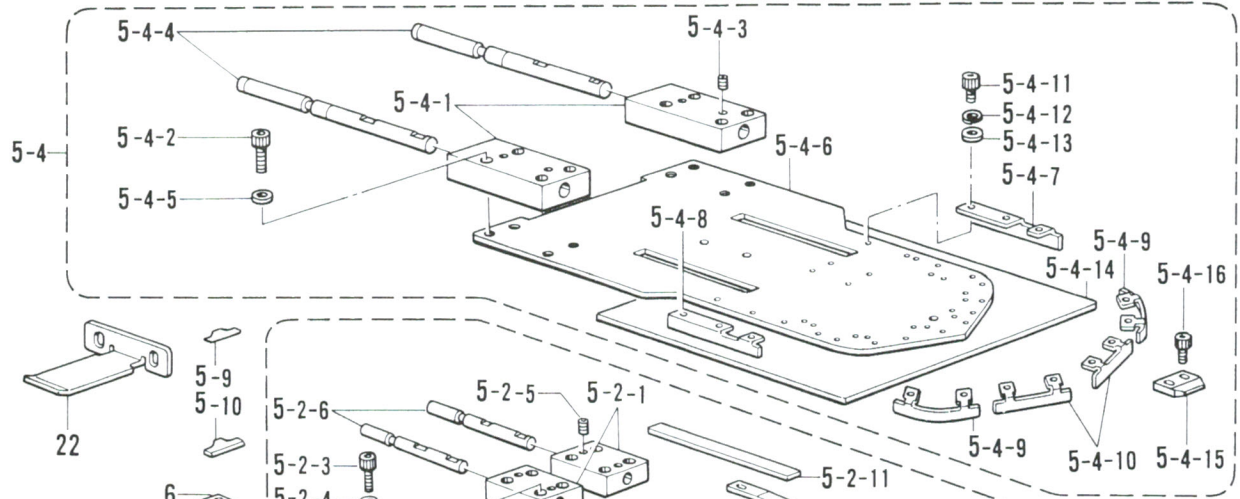
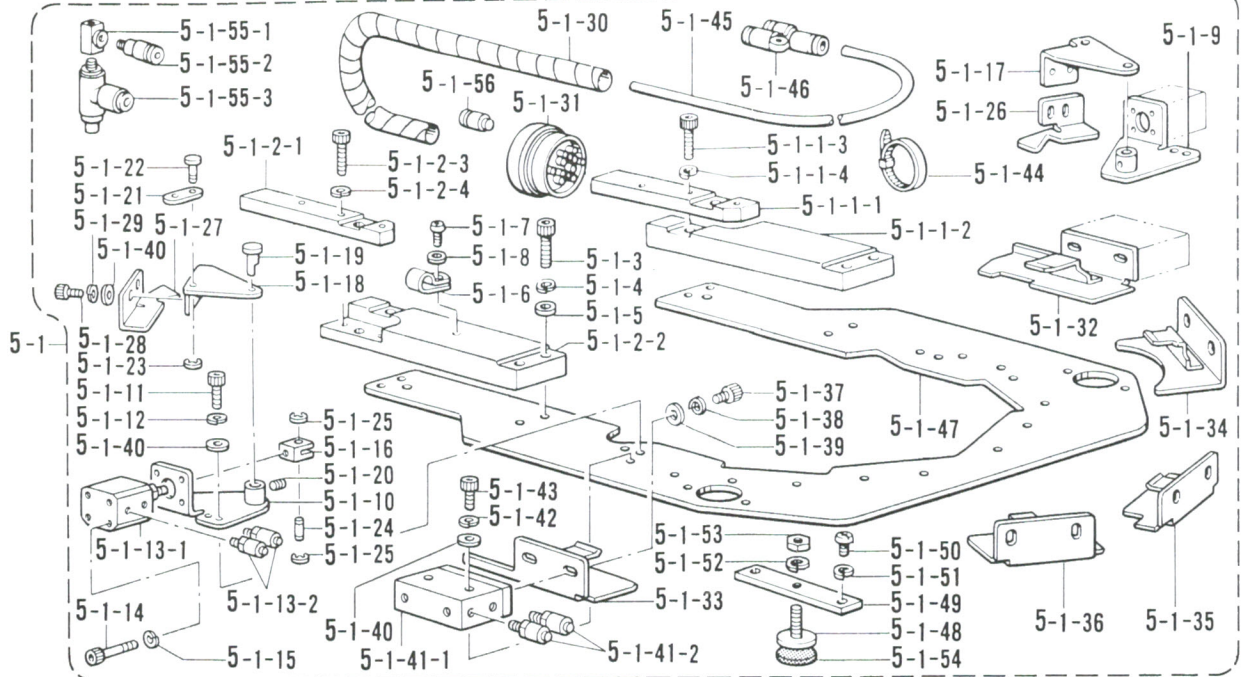

K. 折り曲げ関係 / Folding margin mechanism / Faltungsvorrichtung /
 Mécanisme de marge d'ourlet / Mecanismo de margen de plegado

REF.NO.	CODE	Q'TY	ヒンメイ	NAME OF PARTS	RMKS
10	S24888001	1	コネクタブロックRクミ	CONNECT BLOCK (R) ASSEMBLY	
10-1	S24460001	1	コネクタブロックR-1	CONNECT BLOCK (R-1)	
10-2	S24461001	1	コネクタブロックR-2	CONNECT BLOCK (R-2)	
10-3	018502022	2	アナボルト5X20	BOLT 5X20	
10-4	028050242	2	ハネサカネ2-5	SPRING WASHER 2-5	
11	S24889001	1	コネクタブロックLクミ	CONNECT BLOCK (L) ASSEMBLY	
11-1	S24458001	1	コネクタブロックL-1	CONNECT BLOCK (L-1)	
11-2	S24459001	1	コネクタブロックL-2	CONNECT BLOCK (L-2)	
11-3	018502022	2	アナボルト5X20	BOLT 5X20	
11-4	028050242	2	ハネサカネ2-5	SPRING WASHER 2-5	
14	S21121001	1	コネクタブロックSSR	CONNECT BLOCK (SSR)	
15	S21122001	1	コネクタブロックSSL	CONNECT BLOCK (SSL)	
16	S21123001	2	コネクタブロックS	CONNECT BLOCK (S)	
17	S24828000	1	クランプリンク"12	CLAMP RING 12	
18	S24890001	1	イチキメイト(ラベルソウチ)	POSITIONING PLATE (LABEL DEVICE)	
19	062400616	2	ナヘ"COM4X6	SCREW 4X6	
20	028040243	2	ハネサカネ2-4	SPRING WASHER 2-4	
21	025040233	2	ヒラサカネチユウ4	PLAIN WASHER 4	
22	S24893000	1	オリイタウエJ	FOLDING PLATE UPPER (J)	

K. 折り曲げ関係 / Folding margin mechanism / Faltungsvorrichtung /
 Mécanisme de marge d'ourlet / Mecanismo de margen de plegado

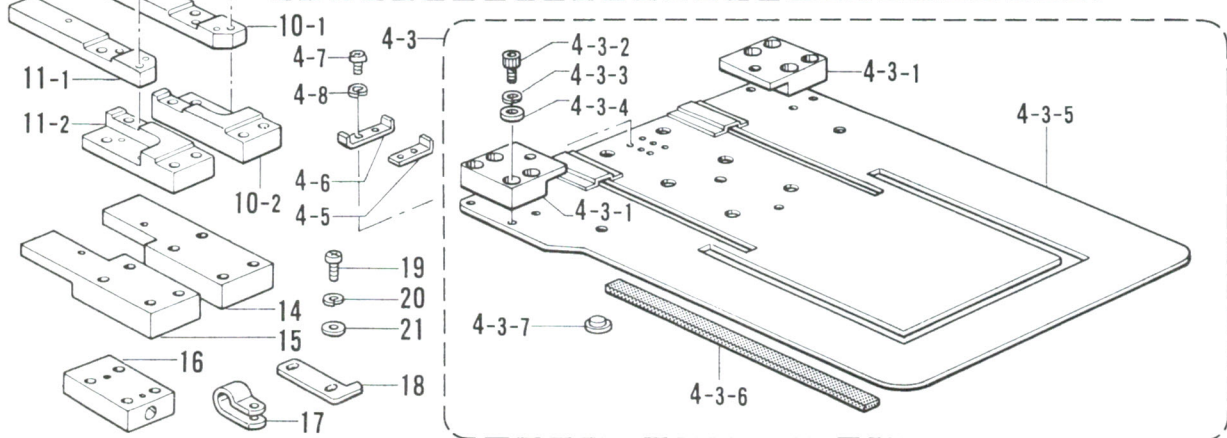
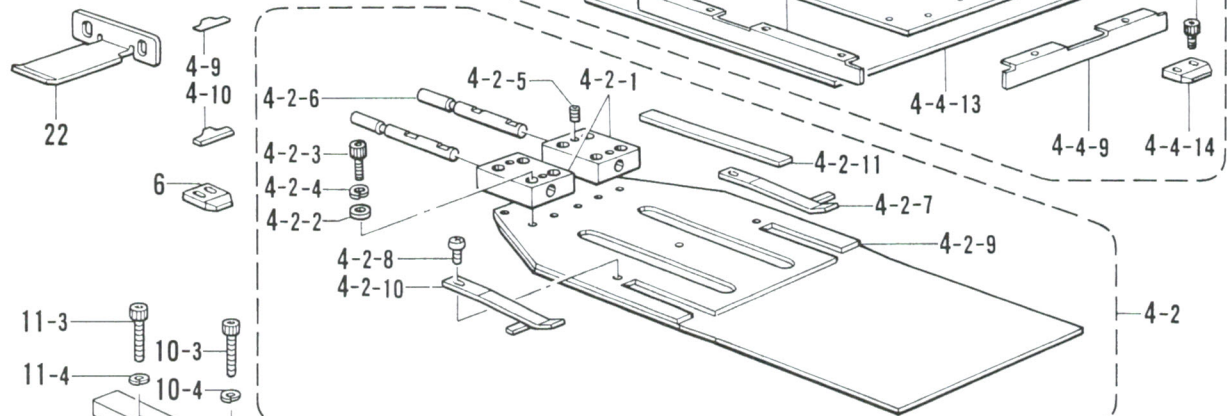
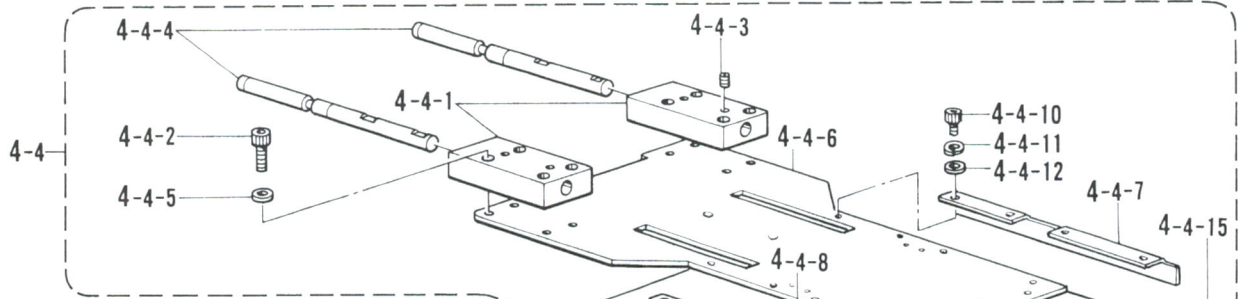
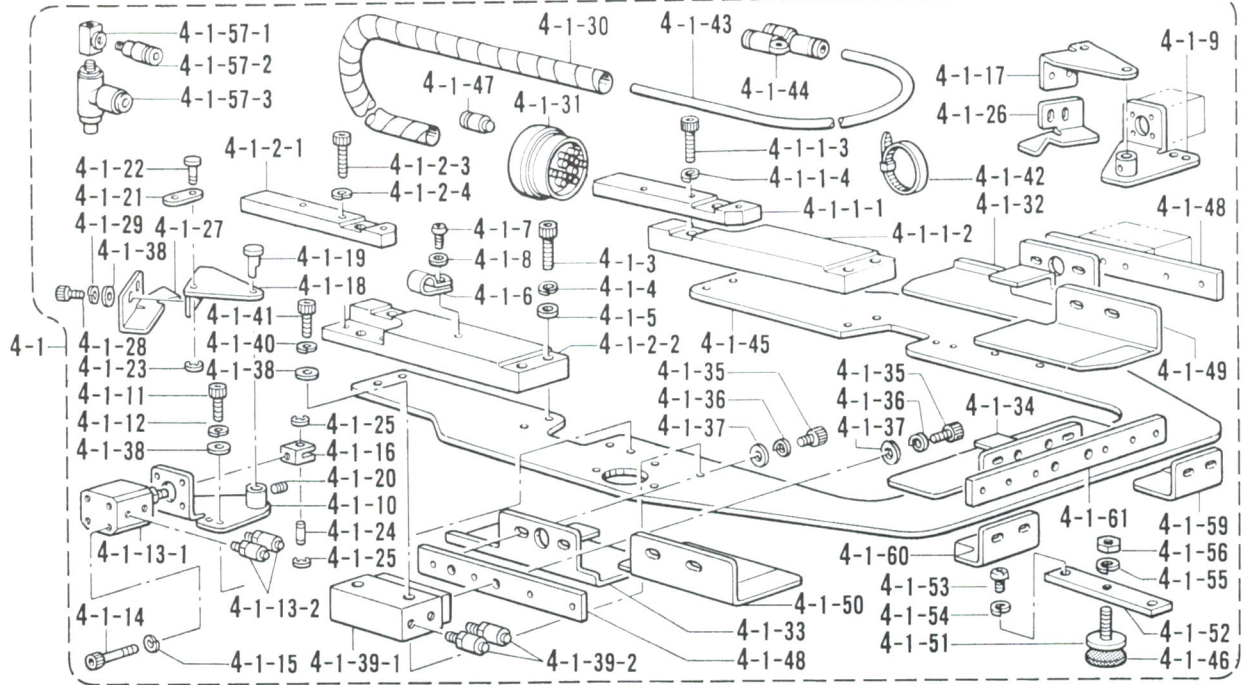

K. 折り曲げ関係 / Folding margin mechanism / Faltungsvorrichtung /
Mécanisme de marge d'ourlet / Mecanismo de margen de plegado

REF.NO.	CODE	Q'TY	ヒンメイ	NAME OF PARTS	RMKS
4-1-49	S24856---	1	オリイタRD-4カクJ	TUCKING BLADE (RD-SQUARE-J)	
4-1-50	S24857---	1	オリイタLD-4カクJ	TUCKING BLADE (LD-SQUARE-J)	
4-1-51	S12291001	2	アシヤストネジ	ADJUST SCREW	
4-1-52	S12294001	2	トリツケイタ(オリイタ)	FITTING PLATE (FOLDING CLAMP)	
4-1-53	062401006	4	ナヘコ4X10	SCREW 4X10	
4-1-54	028040243	4	ハネサカネ2-4	SPRING WASHER 2-4	
4-1-55	028060243	2	ハネサカネ2-6	SPRING WASHER 2-6	
4-1-56	021060206	2	2シユナツト6	NUT 6	
4-1-57	S15564000	1	チーM5クミ	T-M5 ASSEMBLY	
4-1-57-1	S15563000	1	チーM5	T-M5	
4-1-57-2	S04905000	1	ハーフユニオン	HALF UNION	
4-1-57-3	S14328000	2	シホリハ	THROTTLE VALVE	
4-1-59	S24858---	1	オリイタRDD-4カクJ	TUCKING BLADE (RDD-SQUARE-J)	
4-1-60	S24859---	1	オリイタLDD-4カクJ	TUCKING BLADE (LDD-SQUARE-J)	
4-1-61	S24860---	1	オリイタササエD-4カクJ	TUCKING BLADE SUPPORT (D-SQUARE-J)	
4-2	S24825---	1	ゲーシクミ-4カクJ	CENTER BLADE ASSEMBLY (SQUARE-J)	
4-2-1	S12107001	2	コネクタブロック(GAGE)	CONNECT BLOCK (CENTER BLADE)(GAGE)	
4-2-2	158722002	8	サカネ4.2	WASHER 4.2	
4-2-3	018402032	8	アナボルト4X20	BOLT 4X20	
4-2-4	028040242	8	ハネサカネ2-4	SPRING WASHER 2-4	
4-2-5	014500522	4	アタメネジ5クホミ	SET SCREW 5	
4-2-6	S12108001	2	コネクトピン(ゲーシ)	PIN (CENTER BLADE)(GAGE)	
4-2-7	S29187---	1	イタハネR0.8-4カクJ	PLATE SPRING (R-0.8-SQUARE-J)	
4-2-8	060300414	4	ハイント3X4	SCREW 3X4	
4-2-9	S24820---	1	ゲーシ-4カクJ	CENTER BLADE (SQUARE-J)	
4-2-10	S29188---	1	イタハネL0.8-4カクJ	PLATE SPRING (L-0.8-SQUARE-J)	
4-2-11	S24802000	2	ウケイタ(ゲーシ)1.6J	SUPPORT PLATE (CENTER BLADE)(GAGE-1.6J)	
4-3	S24821---	1	オサエクミ-4カクJ	SEWING CLAMP ASSEMBLY (SQUARE-J)	
4-3-1	S12110001	2	コネクタブロック(オサエ)	CONNECT BLOCK (PRESSER)	
4-3-2	018401022	8	アナボルト4X10	BOLT 4X10	
4-3-3	028040242	8	ハネサカネ2-4	SPRING WASHER 2-4	
4-3-4	158722002	8	サカネ4.2	WASHER 4.2	
4-3-5	S24822---	1	オサエ-4カクJ	SEWING CLAMP (SQUARE-J)	
4-3-6	S12298000	2	フォーム3X15X1000	FORM 3X15X1000	
4-3-7	S12279000	6	ウケイタ(オサエ)	SUPPORT PLATE (PRESSER)	
4-4	S24823---	1	ナカオサエクミ-4カクJ	INNER CLAMP ASSEMBLY (SQUARE-J)	
4-4-1	S12113001	2	コネクタブロック(ナカ)	CONNECT BLOCK (INNER)	
4-4-2	018502522	8	アナボルト5X25	BOLT 5X25	
4-4-3	014500522	4	アタメネジ5クホミ	SET SCREW 5	
4-4-4	S12114001	2	コネクトピン(ナカ)	PIN (INNER)	
4-4-5	S20246001	8	ヒラサカネタ15	PLAIN WASHER 5	
4-4-6	S24824---	1	ナカオサエ-4カクJ	INNER CLAMP (SQUARE-J)	
4-4-7	S24872---	1	ナカオサエウ1-4カクJ	INNER CLAMP UPPER-1 (SQUARE-J)	
4-4-8	S24873---	1	ナカオサエウ2-4カクJ	INNER CLAMP UPPER-2 (SQUARE-J)	
4-4-9	S24874---	1	ナカオサエウ3-4カクJ	INNER CLAMP UPPER-3 (SQUARE-J)	
4-4-10	018300532	10	アナボルト3X5	BOLT 3X5	
4-4-11	028030242	10	ハネサカネ2-3	SPRING WASHER 2-3	
4-4-12	025030232	10	ヒラサカネチユウ3	PLAIN WASHER 3	
4-4-13	S12117000	1	フォーム2X200X200	FORM 2X200X200	
4-4-14	S12487000	3	オリイタウケ(ナカオサエ)	FOLDING PLATE SUPPORT (INNER CLAMP)	
4-4-15	018300532	6	アナボルト3X5	BOLT 3X5	
4-5	S12111001	3	スリットC	SLIT (C)	
4-6	S12112001	3	スリットD	SLIT (D)	
4-7	062300502	6	ナヘコ3X5	SCREW 3X5	
4-8	028030242	6	ハネサカネ2-3	SPRING WASHER 2-3	
4-9	S16514000	2	スパーサ0.05	SPACER 0.05	
4-10	S16513000	2	スパーサ0.1	SPACER 0.1	
6	S12494000	1	オリイタウケシヨウ	FOLDING PLATE SUPPORT (SMALL)	

K. 折り曲げ関係/Folding margin mechanism/Faltungsvorrichtung/
 Mécanisme de marge d'ourlet/Mecanismo de margen de plegado

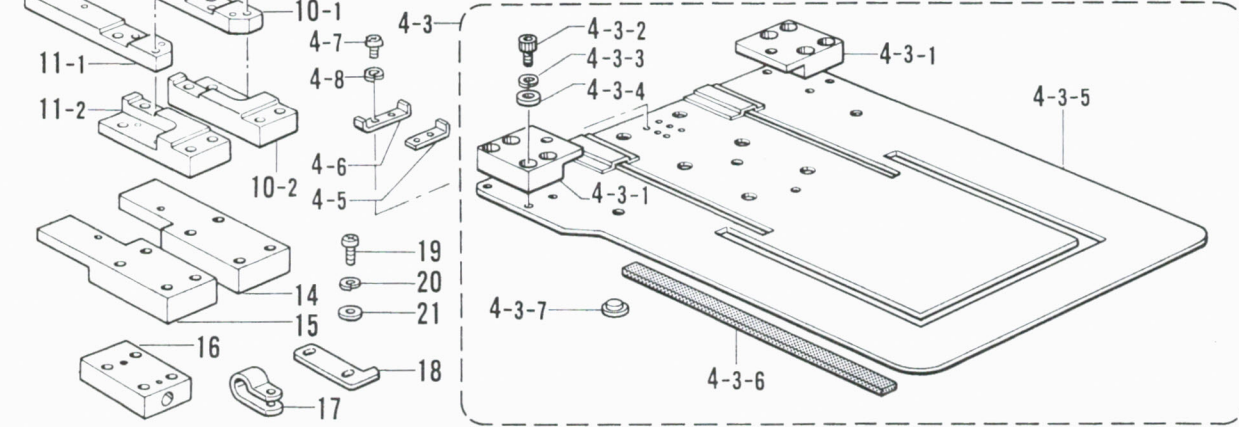
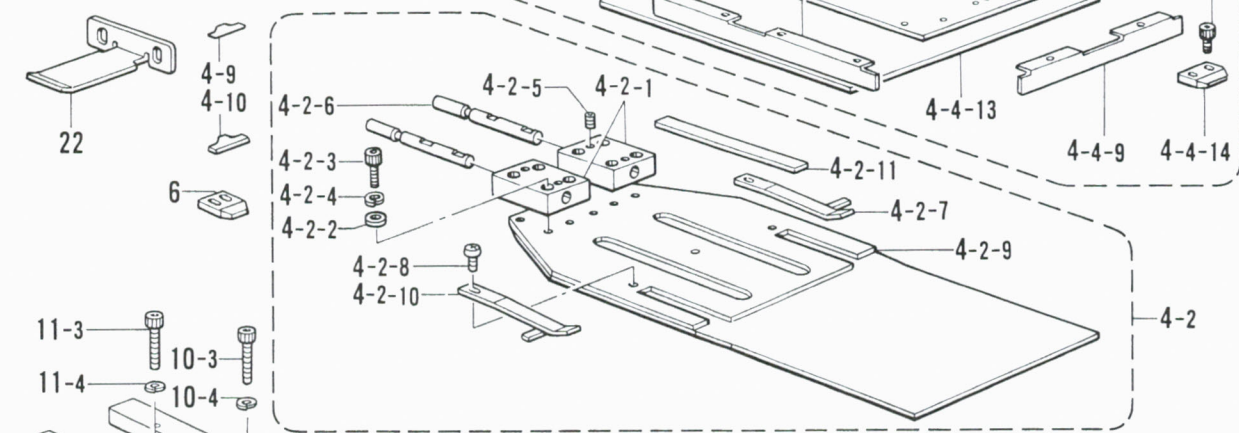
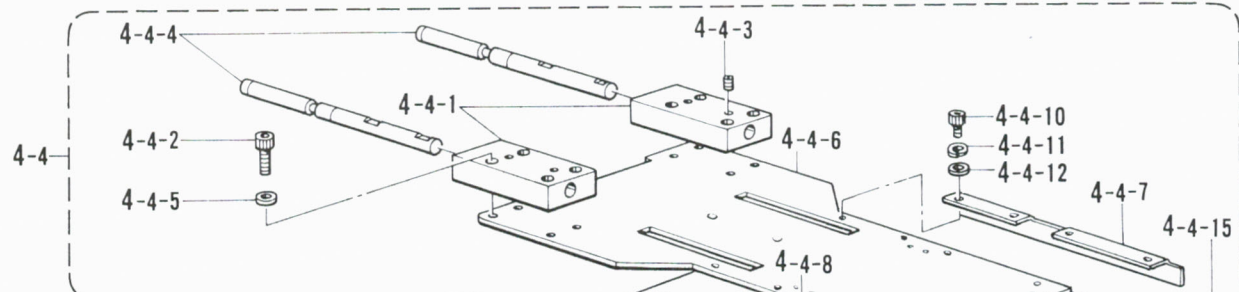
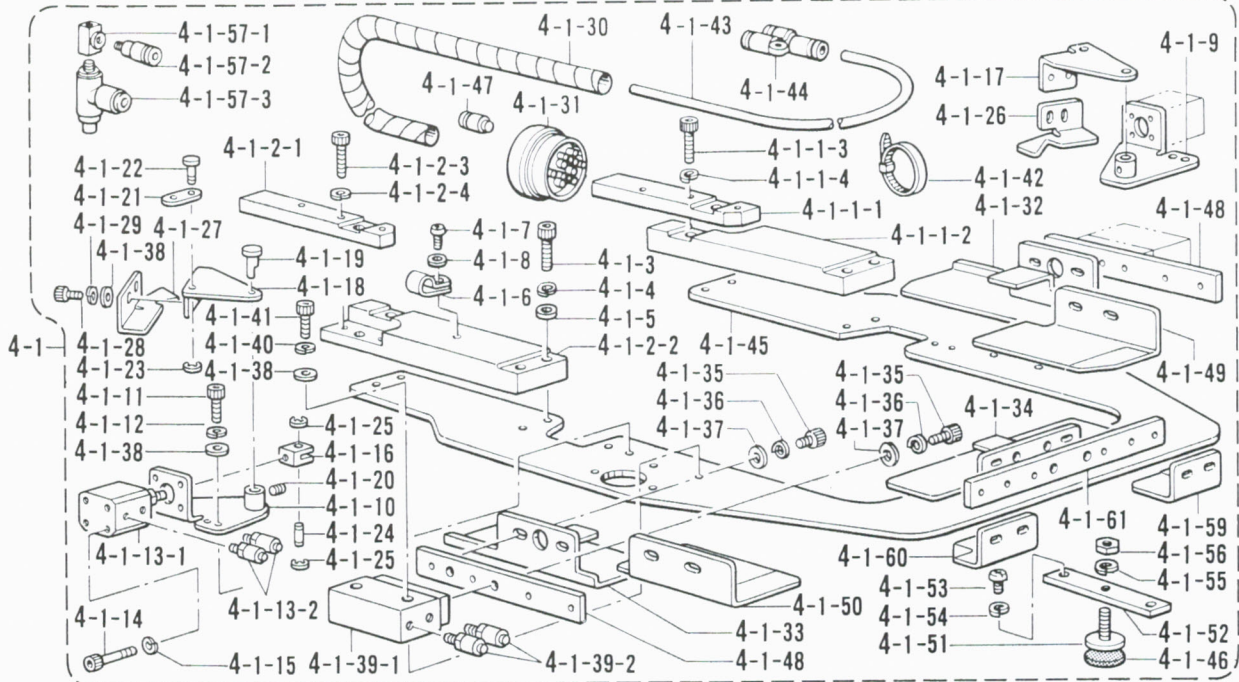

K. 折り曲げ関係 / Folding margin mechanism / Faltungsvorrichtung /
Mécanisme de marge d'ourlet / Mecanismo de margen de plegado

REF.NO.	CODE	Q'TY	ヒンメイ	NAME OF PARTS	RMKS
4	S24817---	1	オリキクミ-4カクJ	FOLDING GROUP ASSEMBLY (SQUARE-J)	
4-1	S24818---	1	オリササエクミ-4カクJ	FOLDING CLAMP ASSEMBLY (SQUARE-J)	
4-1-1	S24886001	1	コネクタブ"ロツクSRクミ	CONNECT BLOCK (SR) ASSEMBLY	
4-1-1-1	S24456001	1	コネクタブ"ロツクSR-1	CONNECT BLOCK (SR-1)	
4-1-1-2	S24457001	1	コネクタブ"ロツクSR-2	CONNECT BLOCK (SR-2)	
4-1-1-3	018502022	2	アナホ"ルト5X20	BOLT 5X20	
4-1-1-4	028050242	2	ハ"ネサ"カ"ネ2-5	SPRING WASHER 2-5	
4-1-2	S24887001	1	コネクタブ"ロツクSLクミ	CONNECT BLOCK (SL) ASSEMBLY	
4-1-2-1	S24454001	1	コネクタブ"ロツクSL-1	CONNECT BLOCK (SL-1)	
4-1-2-2	S24455001	1	コネクタブ"ロツクSL-2	CONNECT BLOCK (SL-2)	
4-1-2-3	018502022	2	アナホ"ルト5X20	BOLT 5X20	
4-1-2-4	028050242	2	ハ"ネサ"カ"ネ2-5	SPRING WASHER 2-5	
4-1-3	018502522	8	アナホ"ルト5X25	BOLT 5X25	
4-1-4	028050242	8	ハ"ネサ"カ"ネ2-5	SPRING WASHER 2-5	
4-1-5	S20246001	8	ヒラサ"カ"ネタ"イ5	PLAIN WASHER 5	
4-1-6	552907000	1	コート"ホルタ"10N	CORD HOLDER (10N)	
4-1-7	062401006	1	ナヘ"コ4X10	SCREW 4X10	
4-1-8	025040233	1	ヒラサ"カ"ネチユウ4	PLAIN WASHER 4	
4-1-9	S24783001	1	メントリト"ダ"イRJ	TUCKING BASE (RJ)	
4-1-10	S24784001	1	メントリト"ダ"イLJ	TUCKING BASE (LJ)	
4-1-11	018400832	4	アナホ"ルト4X8	BOLT 4X8	
4-1-12	028040242	4	ハ"ネサ"カ"ネ2-4	SPRING WASHER 2-4	
4-1-13	S12090000	2	シリンダ"-12X10クミ	CYLINDER 12X10 ASSEMBLY	
4-1-13-1	S12091000	2	シリンダ"-12X10	CYLINDER 12X10	
4-1-13-2	S11433000	4	ホ-スニツヅ"ル4M5	HOSE NIPPLE 4M5	
4-1-14	S12092000	8	CQ2ホ"ルトM3X30	CQ2 BOLT M3X30	
4-1-15	028030243	8	ハ"ネサ"カ"ネ2-3	SPRING WASHER 2-3	
4-1-16	S12093001	2	ナツクル	KNUCKLE	
4-1-17	S24785000	1	メントリヒンジ"RJ	HINGE (RJ)	
4-1-18	S24786000	1	メントリヒンジ"LJ	HINGE (LJ)	
4-1-19	S12096001	2	ヒンジ"ピン	PIN	
4-1-20	014400522	2	アナクホ"ミ4X5	SET SCREW 4X5	
4-1-21	S12097001	2	タイフ"レート	TIE PLATE	
4-1-22	S12098001	2	ピン	PIN	
4-1-23	048050342	2	トメフE5	STOP RING E5	
4-1-24	S12099001	2	ナツクルピン	PIN	
4-1-25	048050342	4	トメフE5	STOP RING E5	
4-1-26	S24787000	1	メントリイタRJ	TUCKING BLADE (RJ)	
4-1-27	S24788000	1	メントリイタLJ	TUCKING BLADE (LJ)	
4-1-28	018400632	4	アナホ"ルト4X6	BOLT 4X6	
4-1-29	028040242	4	ハ"ネサ"カ"ネ2-4	SPRING WASHER 2-4	
4-1-30	S12214000	1	スパ"イラル640L	SPIRAL 640L	
4-1-31	S12106000	1	マルチコネクタP	MULTI CONNECTOR (P)	
4-1-32	S24853---	1	オリイタR-4カクJ	TUCKING BLADE (R-SQUARE-J)	
4-1-33	S24854---	1	オリイタL-4カクJ	TUCKING BLADE (L-SQUARE-J)	
4-1-34	S24855---	1	オリイタD-4カクJ	TUCKING BLADE (D-SQUARE-J)	
4-1-35	018500822	20	アナホ"ルト5X8	BOLT 5X8	
4-1-36	028050242	20	ハ"ネサ"カ"ネ2-5	SPRING WASHER 2-5	
4-1-37	S20246001	20	ヒラサ"カ"ネタ"イ5	PLAIN WASHER 5	
4-1-38	158722002	14	サ"カ"ネ4.2	WASHER 4.2	
4-1-39	S24789000	3	ツインロツト"シリンダ"ークミ	TWIN ROD CYLINDER ASSEMBLY	
4-1-39-1	S24790000	3	ツインロツト"シリンダ"-20	TWIN ROD CYLINDER 20	
4-1-39-2	S11433000	6	ホ-スニツヅ"ル4M5	HOSE NIPPLE 4M5	
4-1-40	028040242	6	ハ"ネサ"カ"ネ2-4	SPRING WASHER 2-4	
4-1-41	018403022	6	アナホ"ルト4X30	BOLT 4X30	
4-1-42	S04159000	4	ハ"ント"1M	BAND 1M	
4-1-43	S12205000	1	エアホ-ス4X2.5-29	AIR TUBE 4X2.5-29 (L=7500)	
4-1-44	S12104000	4	ユニオンワイ4	UNION-Y 4	
4-1-45	S24819---	1	オリササエ-4カクJ	FOLDING CLAMP (SQUARE-J)	
4-1-46	S12297000	2	スポンジ"2-30	SPONGE 2X15X1200	
4-1-47	S19555000	2	キャツヅ"4	CAP 4	
4-1-48	S12469---	2	オリイタササエ-4カク	FOLDING PLATE SUPPORT (SQUARE)	

K. 折り曲げ関係 / Folding margin mechanism / Faltungsvorrichtung /
 Mécanisme de marge d'ourlet / Mecanismo de margen de plegado

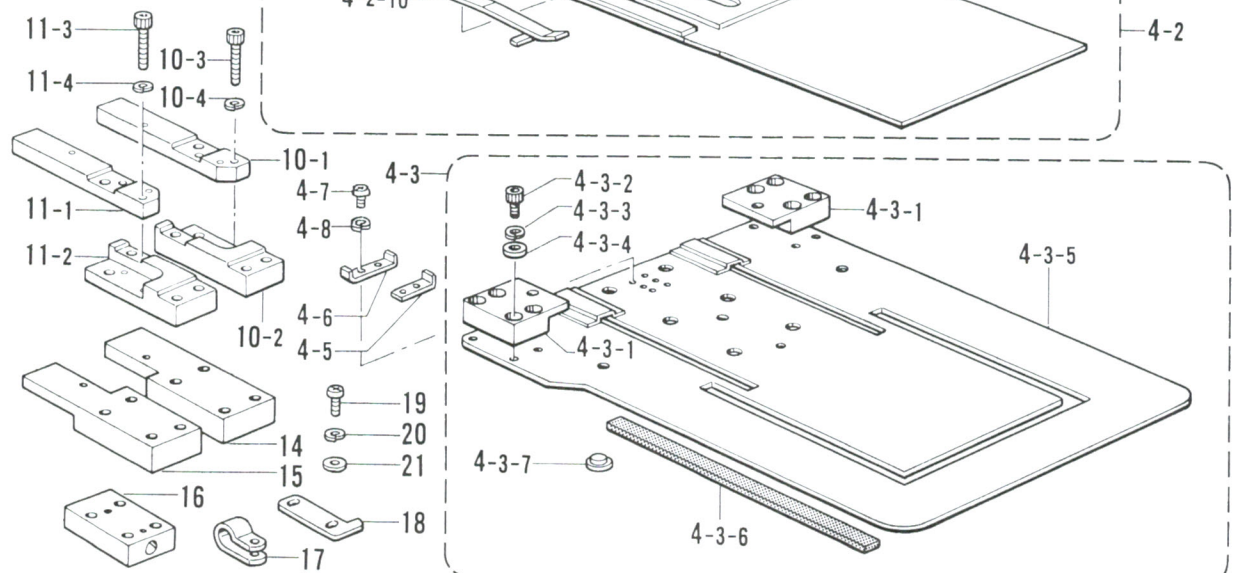
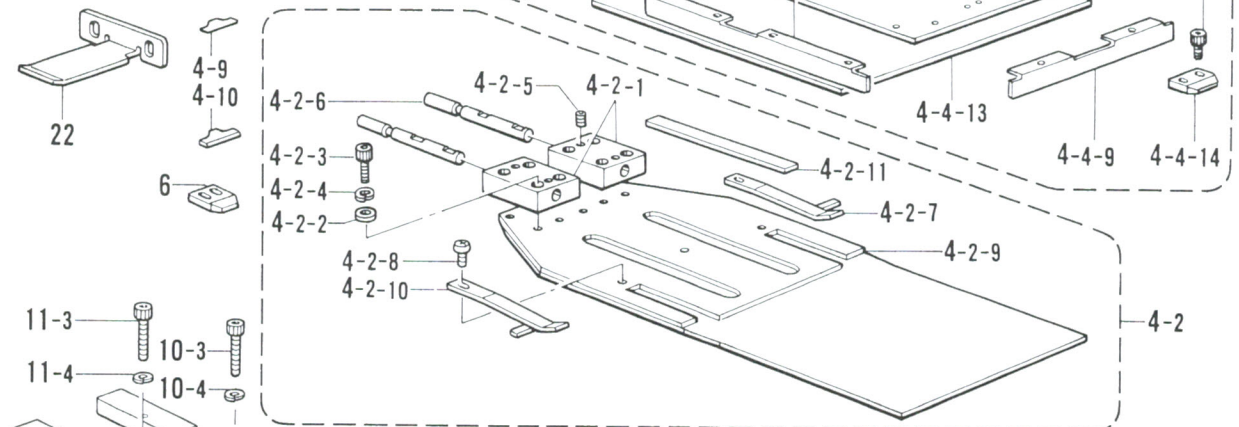
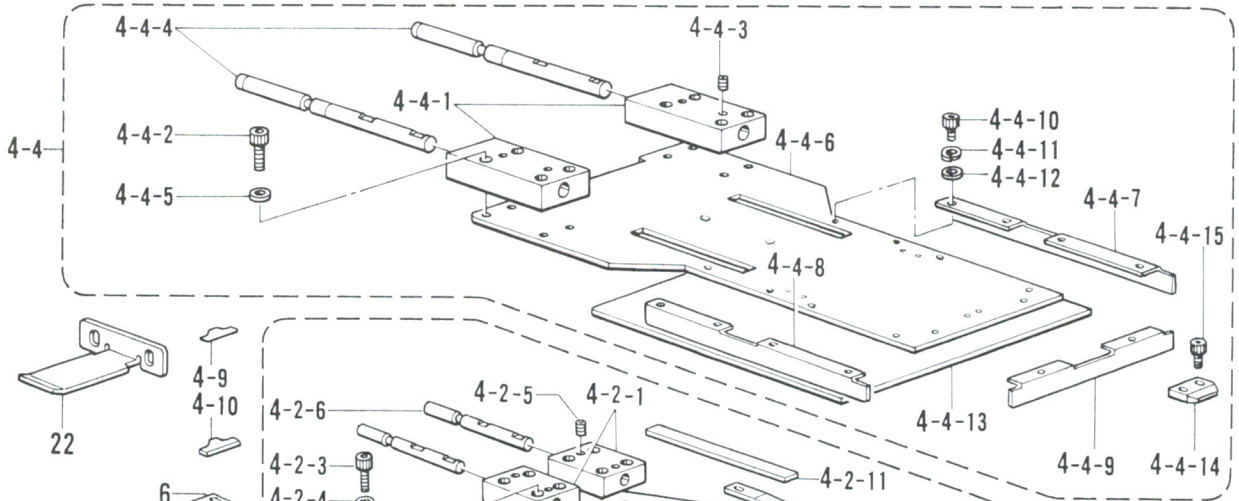
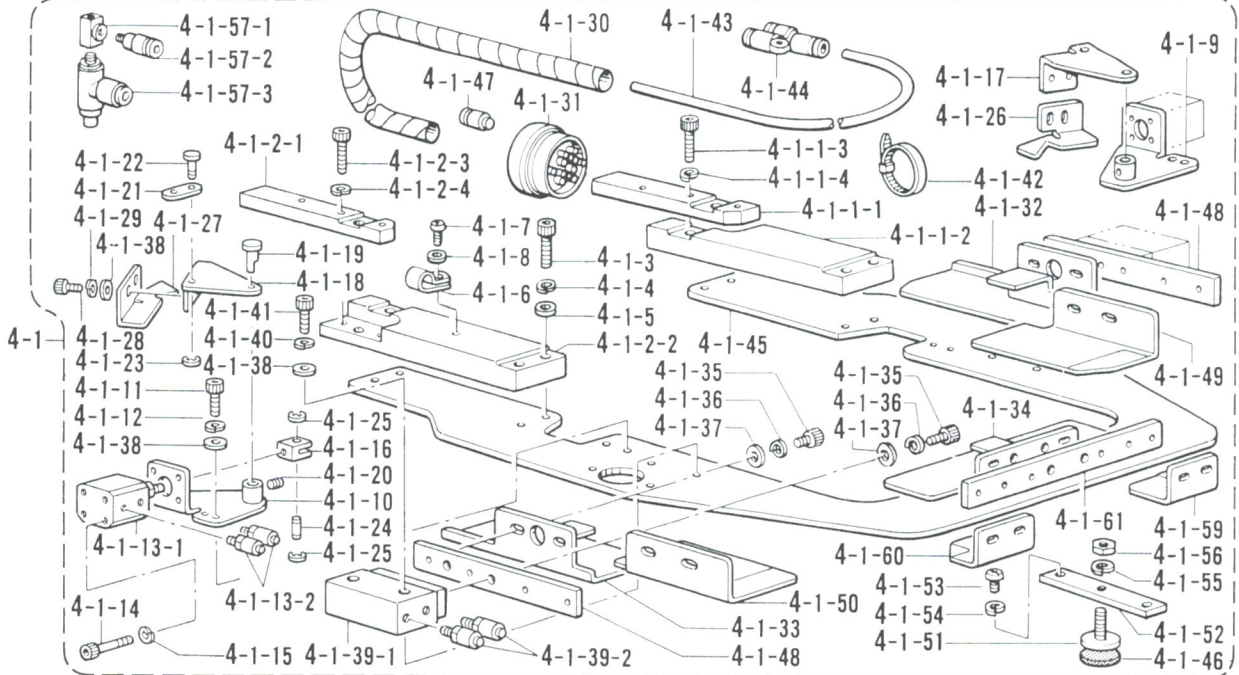

K. 折り曲げ関係 / Folding margin mechanism / Faltungsvorrichtung /
 Mécanisme de marge d'ourlet / Mecanismo de margen de plegado

REF.NO.	CODE	Q'TY	ヒンメイ	NAME OF PARTS	RMKS
11	S24889001	1	コネクタブロックLクミ	CONNECT BLOCK (L) ASSEMBLY	
11-1	S24458001	1	コネクタブロックL-1	CONNECT BLOCK (L-1)	
11-2	S24459001	1	コネクタブロックL-2	CONNECT BLOCK (L-2)	
11-3	018502022	2	アナホルト5X20	BOLT 5X20	
11-4	028050242	2	ハ"ネサ"カ"ネ2-5	SPRING WASHER 2-5	
14	S21121001	1	コネクタブロックSSR	CONNECT BLOCK (SSR)	
15	S21122001	1	コネクタブロックSSL	CONNECT BLOCK (SSL)	
16	S21123001	2	コネクタブロックS	CONNECT BLOCK (S)	
17	S24828000	1	クランプ"リンク"12	CLAMP RING 12	
18	S24890001	1	イチキ"メイト(ラヘルソウチ)	POSITIONING PLATE (LABEL DEVICE)	
19	062400616	2	ナヘル"コM4X6	SCREW 4X6	
20	028040243	2	ハ"ネサ"カ"ネ2-4	SPRING WASHER 2-4	
21	025040233	2	ヒラサ"カ"ネチユウ4	PLAIN WASHER 4	
22	S24893000	1	オリイタウEJ	FOLDING PLATE UPPER (J)	

K. 折り曲げ関係/Folding margin mechanism/Faltungsvorrichtung/
 Mécanisme de marge d'ourlet/Mecanismo de margen de plegado

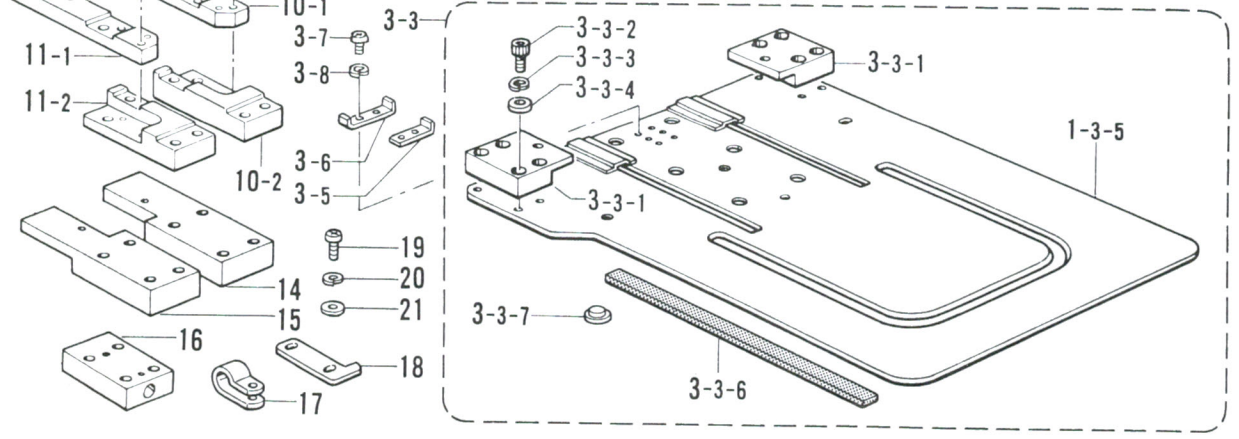
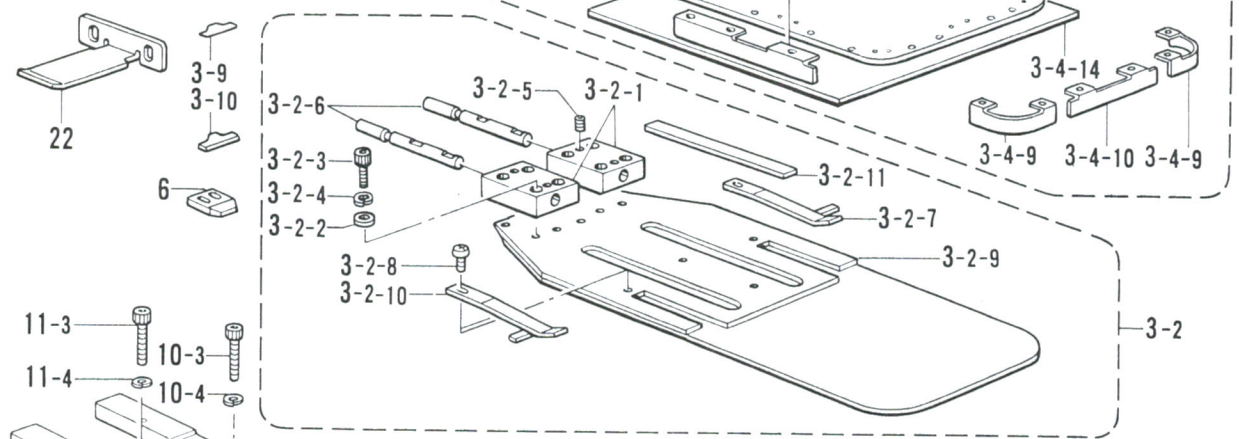
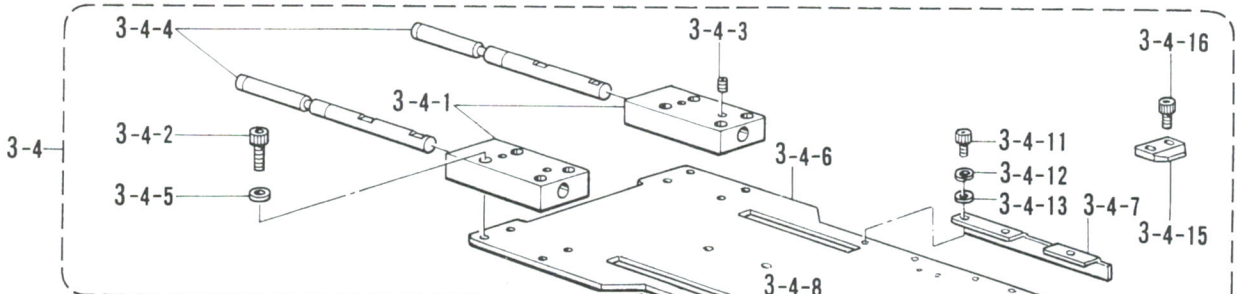
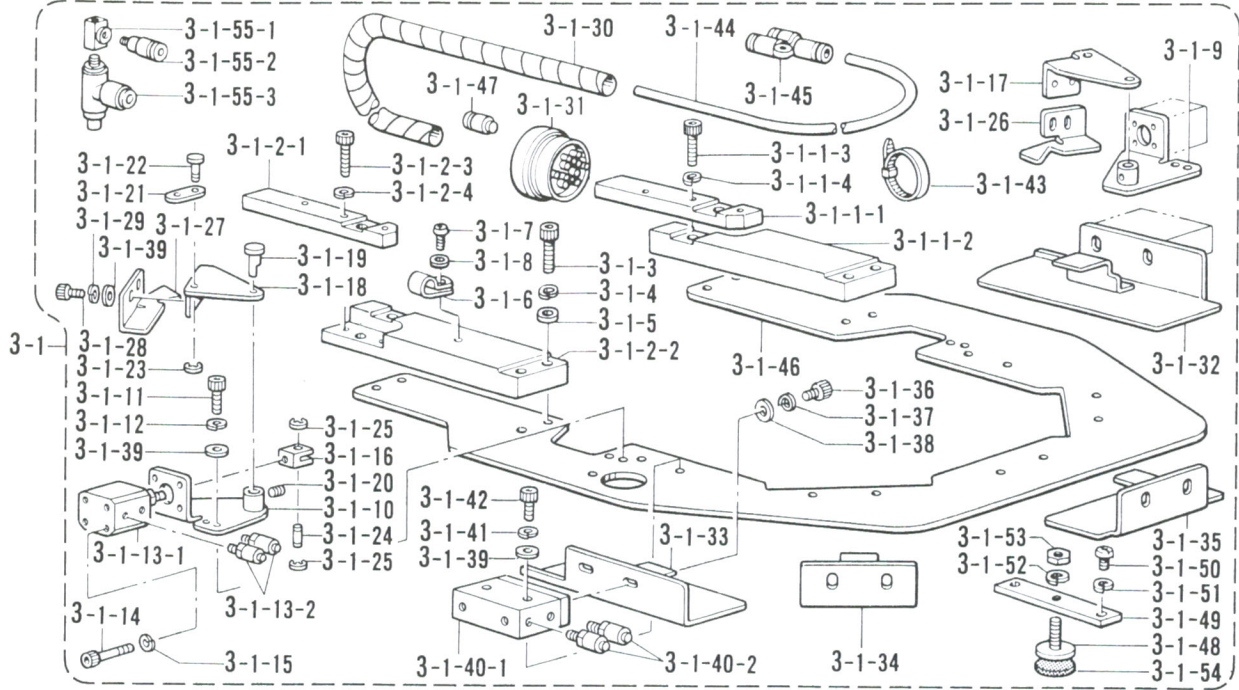

K. 折り曲げ関係 / Folding margin mechanism / Faltungsvorrichtung /
Mécanisme de marge d'ourlet / Mecanismo de margen de plegado

REF.NO.	CODE	Q'TY	ヒンメイ	NAME OF PARTS	RMKS
3-1-49	S12294001	2	トリツケイタ(オリササエ)	FITTING PLATE (FOLDING CLAMP)	
3-1-50	062401006	4	ナヘ"コ4X10	SCREW 4X10	
3-1-51	028040243	4	ハ"ネサ"カ"ネ2-4	SPRING WASHER 2-4	
3-1-52	028060243	2	ハ"ネサ"カ"ネ2-6	SPRING WASHER 2-6	
3-1-53	021060206	2	2シユナツト6	NUT 6	
3-1-54	S12297000	2	スポンジ"2-30	SPONGE 2-30	
3-1-55	S15564000	1	チ-M5クミ	T-M5 ASSEMBLY	
3-1-55-1	S15563000	1	チ-M5	T-M5	
3-1-55-2	S04905000	1	ハーフユニオン	HALF UNION	
3-1-55-3	S14328000	2	シホ"リヘ"ン	THROTTLE VALVE	
3-2	S24811---	1	ケ-ジ"クミ-マル1J	CENTER BLADE ASSEMBLY (ROUND-1J)	
3-2-1	S12107001	2	コネクタブ"ロツク(GAGE)	CONNECT BLOCK (CENTER BLADE)(GAGE)	
3-2-2	158722002	8	サ"カ"ネ4.2	WASHER 4.2	
3-2-3	018402032	8	アナホ"ルト4X20	BOLT 4X20	
3-2-4	028040242	8	ハ"ネサ"カ"ネ2-4	SPRING WASHER 2-4	
3-2-5	014500522	4	アナトメネシ"5クホ"ミ	SET SCREW 5	
3-2-6	S12108001	2	コネクトピン(ケ-ジ")	PIN (CENTER BLADE)(GAGE)	
3-2-7	S29185---	1	イタハ"ネR0.8-マル1J	PLATE SPRING (R-0.8-ROUND-1J)	
3-2-8	060300414	4	ハ"イント"3X4	SCREW 3X4	
3-2-9	S24812---	1	ケ-ジ"-マル1J	CENTER BLADE (ROUND-1J)	
3-2-10	S29186---	1	イタハ"ネL0.8-マル1J	PLATE SPRING (L-0.8-ROUND-1J)	
3-2-11	S24802000	2	ウケイタ(ケ-ジ")1.6J	SUPPORT PLATE (CENTER BLADE)(GAGE-1.6J)	
3-3	S24813---	1	オサエクミ-マル1J	SEWING CLAMP ASSEMBLY (ROUND-1J)	
3-3-1	S12110001	2	コネクタブ"ロツク(オサエ)	CONNECT BLOCK (PRESSER)	
3-3-2	018401022	8	アナホ"ルト4X10	BOLT 4X10	
3-3-3	028040242	8	ハ"ネサ"カ"ネ2-4	SPRING WASHER 2-4	
3-3-4	158722002	8	サ"カ"ネ4.2	WASHER 4.2	
3-3-5	S24814---	1	オサエ-マル1J	SEWING CLAMP (ROUND-1J)	
3-3-6	S12298000	2	フォーム3X15X1000	FORM 3X15X1000	
3-3-7	S12279000	6	ウケイタ(オサエ)	SUPPORT PLATE (PRESSER)	
3-4	S24815---	1	ナカオサエクミ-マル1J	INNER CLAMP ASSEMBLY (ROUND-1J)	
3-4-1	S12113001	2	コネクタブ"ロツク(ナカ)	CONNECT BLOCK (INNER)	
3-4-2	018502522	8	アナホ"ルト5X25	BOLT 5X25	
3-4-3	014500522	4	アナトメネシ"5クホ"ミ	SET SCREW 5	
3-4-4	S12114001	2	コネクトピン(ナカ)	PIN (INNER)	
3-4-5	S20246001	8	ヒラサ"カ"ネタ"イ5	PLAIN WASHER 5	
3-4-6	S24816---	1	ナカオサエ-マル1J	INNER CLAMP (ROUND-1J)	
3-4-7	S24868---	1	ナカオサエウI1-マル1J	INNER CLAMP UPPER-1 (ROUND-1J)	
3-4-8	S24869---	1	ナカオサエウI2-マル1J	INNER CLAMP UPPER-2 (ROUND-1J)	
3-4-9	S24870---	2	ナカオサエウI3-マル1J	INNER CLAMP UPPER-3 (ROUND-1J)	
3-4-10	S24871---	1	ナカオサエウI4-マル1J	INNER CLAMP UPPER-4 (ROUND-1J)	
3-4-11	018300532	12	アナホ"ルト3X5	BOLT 3X5	
3-4-12	028030242	12	ハ"ネサ"カ"ネ2-3	SPRING WASHER 2-3	
3-4-13	025030232	12	ヒラサ"カ"ネチユウ3	PLAIN WASHER 3	
3-4-14	S12117000	1	フォーム2X200X200	FORM 2X200X200	
3-4-15	S12487000	5	オリイタウケ(ナカオサエ)	FOLDING PLATE SUPPORT (INNER CLAMP)	
3-4-16	018300532	10	アナホ"ルト3X5	BOLT 3X5	
3-5	S12111001	3	スリットC	SLIT (C)	
3-6	S12112001	3	スリットD	SLIT (D)	
3-7	062300502	6	ナヘ"コ3X5	SCREW 3X5	
3-8	028030242	6	ハ"ネサ"カ"ネ2-3	SPRING WASHER 2-3	
3-9	S16514000	2	スヘ-サ0.05	SPACER 0.05	
3-10	S16513000	2	スヘ-サ0.1	SPACER 0.1	
6	S12494000	1	オリイタウケシヨウ	FOLDING PLATE SUPPORT (SMALL)	
10	S24888001	1	コネクタブ"ロツクRクミ	CONNECT BLOCK (R) ASSEMBLY	
10-1	S24460001	1	コネクタブ"ロツクR-1	CONNECT BLOCK (R-1)	
10-2	S24461001	1	コネクタブ"ロツクR-2	CONNECT BLOCK (R-2)	
10-3	018502022	2	アナホ"ルト5X20	BOLT 5X20	
10-4	028050242	2	ハ"ネサ"カ"ネ2-5	SPRING WASHER 2-5	

K. 折り曲げ関係/Folding margin mechanism/Faltungsvorrichtung/
 Mécanisme de marge d'ourlet/Mecanismo de margen de plegado

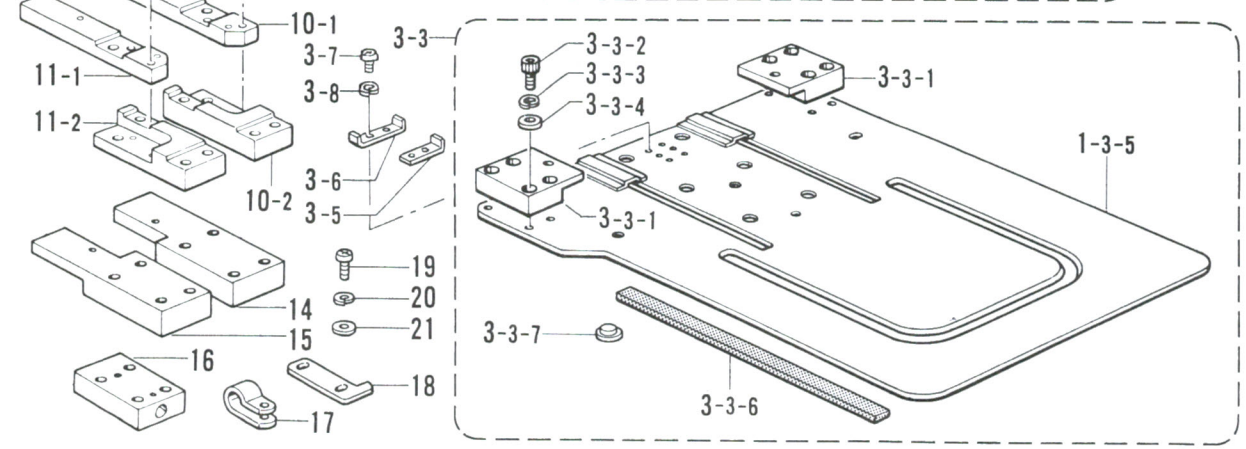
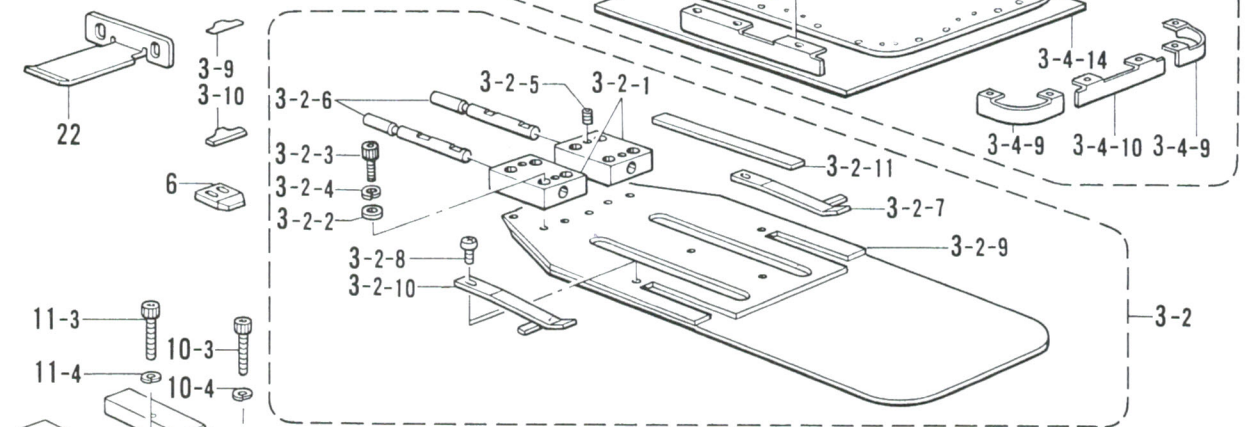
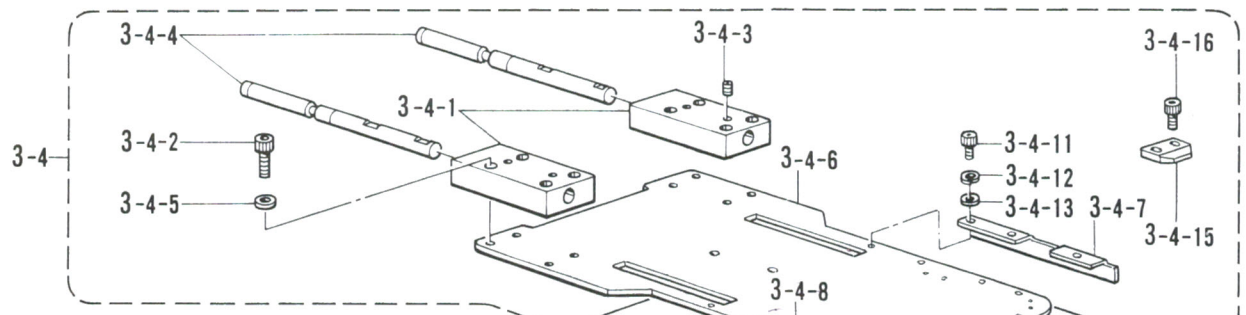
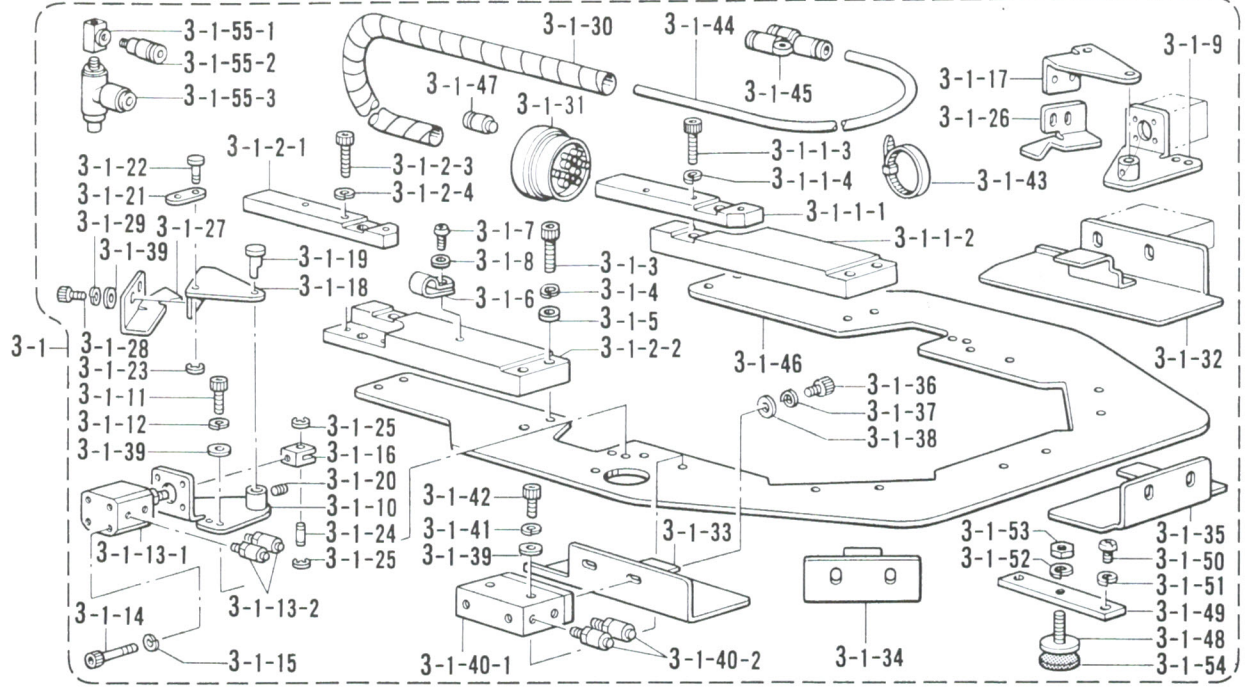

K. 折り曲げ関係 / Folding margin mechanism / Faltungsvorrichtung /
 Mécanisme de marge d'ourlet / Mecanismo de margen de plegado

REF.NO.	CODE	Q'TY	ヒンメイ	NAME OF PARTS	RMKS
3	S24808---	1	オリキクミーマル1J	FOLDING GROUP ASSEMBLY (ROUND-1J)	
3-1	S24809---	1	オリササエクミーマル1J	FOLDING CLAMP ASSEMBLY (ROUND-1J)	
3-1-1	S24886001	1	コネクタブロックSRクミ	CONNECT BLOCK (SR) ASSEMBLY	
3-1-1-1	S24456001	1	コネクタブロックSR-1	CONNECT BLOCK (SR-1)	
3-1-1-2	S24457001	1	コネクタブロックSR-2	CONNECT BLOCK (SR-2)	
3-1-1-3	018502022	2	アナボルト5X20	BOLT 5X20	
3-1-1-4	028050242	2	ハネサカガネ2-5	SPRING WASHER 2-5	
3-1-2	S24887001	1	コネクタブロックSLクミ	CONNECT BLOCK (SL) ASSEMBLY	
3-1-2-1	S24454001	1	コネクタブロックSL-1	CONNECT BLOCK (SL-1)	
3-1-2-2	S24455001	1	コネクタブロックSL-2	CONNECT BLOCK (SL-2)	
3-1-2-3	018502022	2	アナボルト5X20	BOLT 5X20	
3-1-2-4	028050242	2	ハネサカガネ2-5	SPRING WASHER 2-5	
3-1-3	018502522	8	アナボルト5X25	BOLT 5X25	
3-1-4	028050242	8	ハネサカガネ2-5	SPRING WASHER 2-5	
3-1-5	S20246001	8	ヒラサカガネタイ5	PLAIN WASHER 5	
3-1-6	552907000	1	コートホルタ10N	CORD HOLDER (10N)	
3-1-7	062401006	1	ナヘコ4X10	SCREW 4X10	
3-1-8	025040233	1	ヒラサカガネチユウ4	PLAIN WASHER 4	
3-1-9	S24783001	1	メントリトタイRJ	TUCKING BASE (RJ)	
3-1-10	S24784001	1	メントリトタイLJ	TUCKING BASE (LJ)	
3-1-11	018400822	4	アナボルト4X8	BOLT 4X8	
3-1-12	028040242	4	ハネサカガネ2-4	SPRING WASHER 2-4	
3-1-13	S12090000	2	シリンダ-12X10クミ	CYLINDER 12X10 ASSEMBLY	
3-1-13-1	S12091000	2	シリンダ-12X10	CYLINDER 12X10	
3-1-13-2	S11433000	4	ホースニツプル4M5	HOSE NIPPLE 4M5	
3-1-14	S12092000	8	CQ2ボルトM3X30	CQ2 BOLT M3X30	
3-1-15	028030243	8	ハネサカガネ2-3	SPRING WASHER 2-3	
3-1-16	S12093001	2	ナツクル	KNUCKLE	
3-1-17	S24785000	1	メントリヒンシRJ	HINGE (RJ)	
3-1-18	S24786000	1	メントリヒンシLJ	HINGE (LJ)	
3-1-19	S12096001	2	ヒンシピン	PIN	
3-1-20	014400522	2	アナクボミ4X5	SET SCREW 4X5	
3-1-21	S12097001	2	タイプレート	TIE PLATE	
3-1-22	S12098001	2	ピン	PIN	
3-1-23	048050342	2	トメワE5	STOP RING E5	
3-1-24	S12099001	2	ナツクルピン	PIN	
3-1-25	048050342	4	トメワE5	STOP RING E5	
3-1-26	S24787000	1	メントリイタRJ	TUCKING BLADE (RJ)	
3-1-27	S24788000	1	メントリイタLJ	TUCKING BLADE (LJ)	
3-1-28	018400632	4	アナボルト4X6	BOLT 4X6	
3-1-29	028040242	4	ハネサカガネ2-4	SPRING WASHER 2-4	
3-1-30	S12214000	1	スパイラル640L	SPIRAL 640L	
3-1-31	S12106000	1	マルチコネクタP	MULTI CONNECTOR (P)	
3-1-32	S24849---	1	オリイタR-マル1J	TUCKING BLADE (R-ROUND-1J)	
3-1-33	S24850---	1	オリイタL-マル1J	TUCKING BLADE (L-ROUND-1J)	
3-1-34	S24851---	2	オリイタS-マル1J	TUCKING BLADE (S-ROUND-1J)	
3-1-35	S24852---	1	オリイタM-マル1J	TUCKING BLADE (M-ROUND-1J)	
3-1-36	018500822	10	アナボルト5X8	BOLT 5X8	
3-1-37	028050242	10	ハネサカガネ2-5	SPRING WASHER 2-5	
3-1-38	S20246001	10	ヒラサカガネタイ5	PLAIN WASHER 5	
3-1-39	158722002	18	サカガネ4.2	WASHER 4.2	
3-1-40	S24789000	5	ツインロッドシリンダークミ	TWIN ROD CYLINDER ASSEMBLY	
3-1-40-1	S24790000	5	ツインロッドシリンダ-20	TWIN ROD CYLINDER 20	
3-1-40-2	S11433000	10	ホースニツプル4M5	HOSE NIPPLE 4M5	
3-1-41	028040242	10	ハネサカガネ2-4	SPRING WASHER 2-4	
3-1-42	018403022	10	アナボルト4X30	BOLT 4X30	
3-1-43	S04159000	4	バンド1M	BAND 1M	
3-1-44	S12205000	1	エアホース4X2.5-29	AIR TUBE 4X2.5-29 (L=7500)	
3-1-45	S12104000	8	ユニオンワイ4	UNION-Y 4	
3-1-46	S24810---	1	オリササエマル1J	FOLDING CLAMP (ROUND-1J)	
3-1-47	S19555000	2	キャツプ4	CAP 4	
3-1-48	S12291001	2	アジヤストネジ	ADJUST SCREW	

K. 折り曲げ関係 / Folding margin mechanism / Faltungsvorrichtung /
 Mécanisme de marge d'ourlet / Mecanismo de margen de plgado

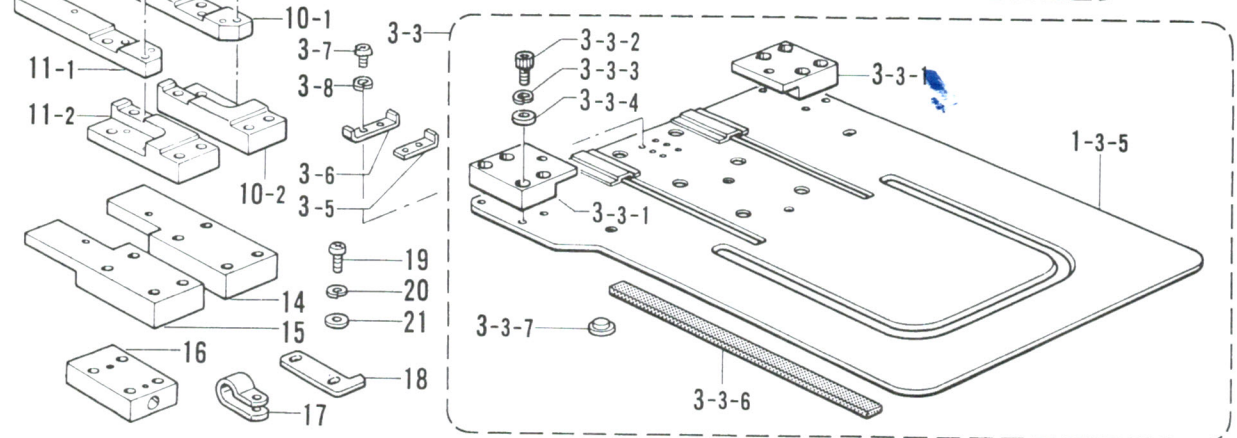
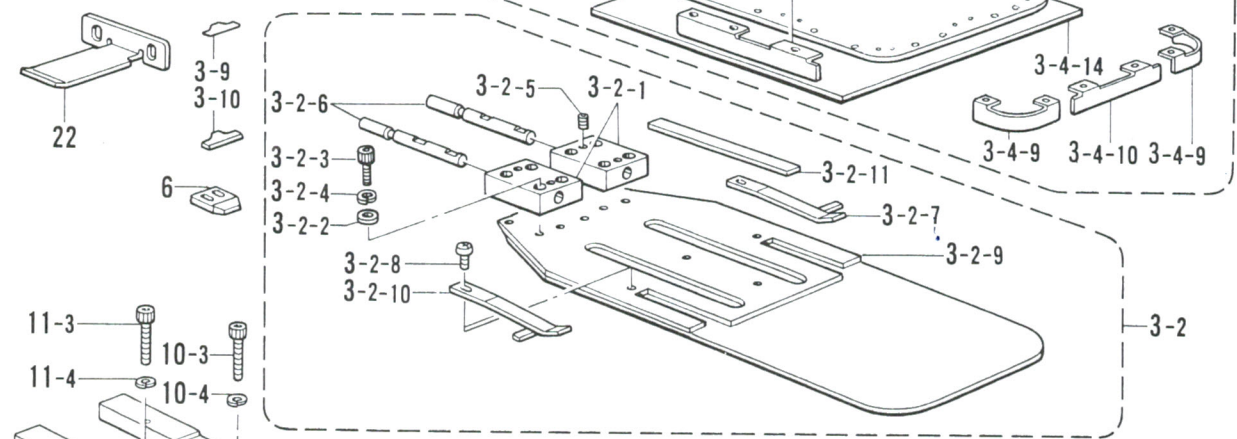
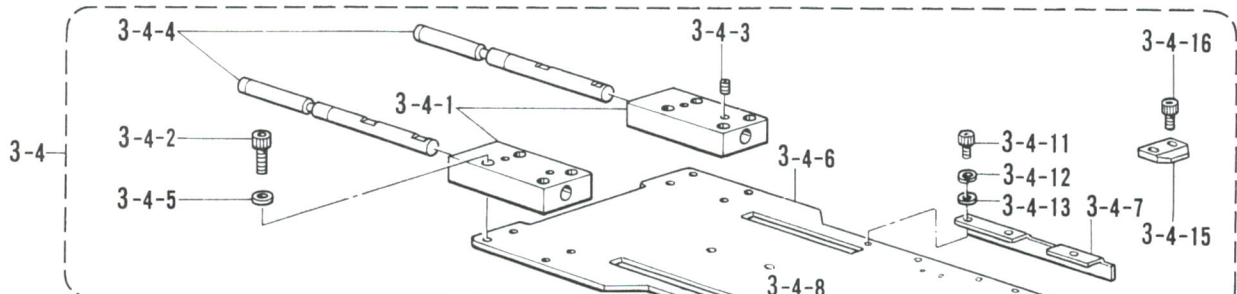
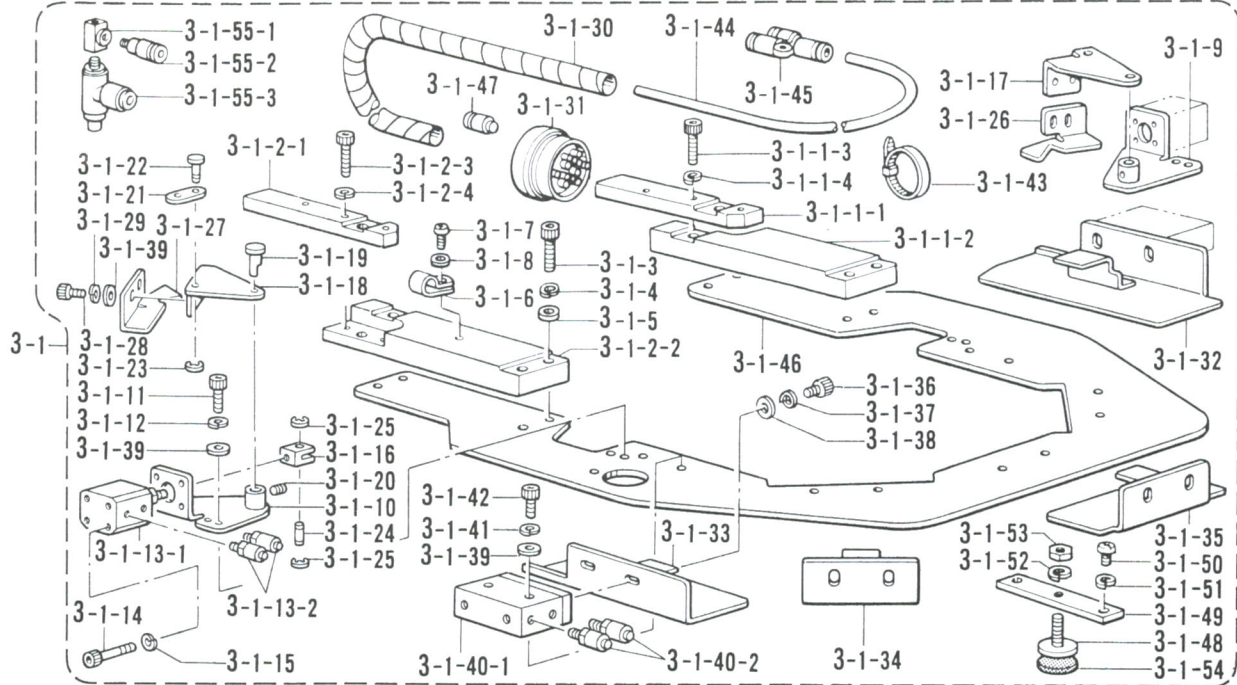

K. 折り曲げ関係 / Folding margin mechanism / Faltungsvorrichtung /
 Mécanisme de marge d'ourlet / Mecanismo de margen de plegado

REF.NO.	CODE	Q'TY	ヒンメイ	NAME OF PARTS	RMKS
11	S24889001	1	コネクタブ"ロックLクミ	CONNECT BLOCK (L) ASSEMBLY	
11-1	S24458001	1	コネクタブ"ロックL-1	CONNECT BLOCK (L-1)	
11-2	S24459001	1	コネクタブ"ロックL-2	CONNECT BLOCK (L-2)	
11-3	018502022	2	アナボ"ルト5X20	BOLT 5X20	
11-4	028050242	2	ハ"ネサ"カ"ネ2-5	SPRING WASHER 2-5	
14	S21121001	1	コネクタブ"ロックSSR	CONNECT BLOCK (SSR)	
15	S21122001	1	コネクタブ"ロックSSL	CONNECT BLOCK (SSL)	
16	S21123001	2	コネクタブ"ロックS	CONNECT BLOCK (S)	
17	S24828000	1	クランプ"リング"12	CLAMP RING 12	
18	S24890001	1	イチキ"メイタ(ラベルソウチ)	POSITIONING PLATE (LABEL DEVICE)	
19	062400616	2	ナヘ"コM4X6	SCREW 4X6	
20	028040243	2	ハ"ネサ"カ"ネ2-4	SPRING WASHER 2-4	
21	025040233	2	ヒラサ"カ"ネチユウ4	PLAIN WASHER 4	
22	S24893000	1	オリイタウEJ	FOLDING PLATE UPPER (J)	

K. 折り曲げ関係 / Folding margin mechanism / Faltungsvorrichtung /
 Mécanisme de marge d'ourlet / Mecanismo de margen de plegado

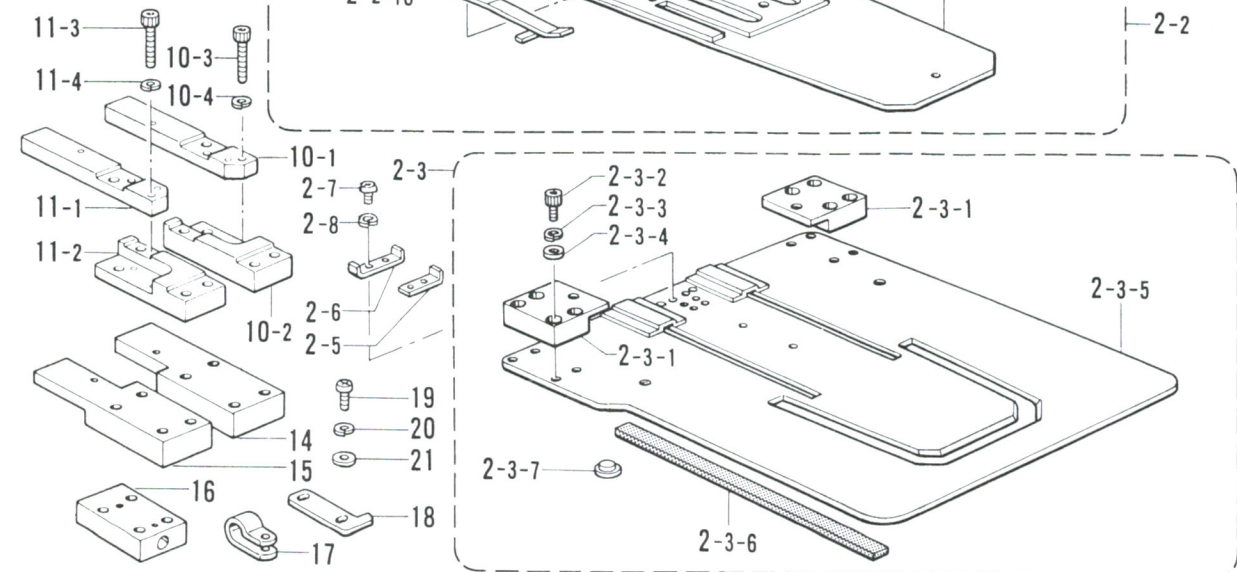
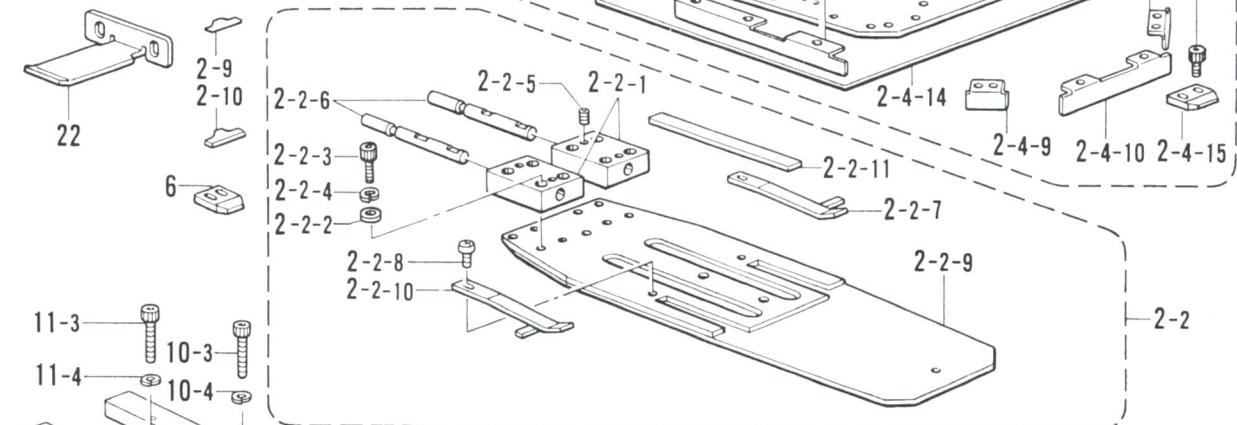
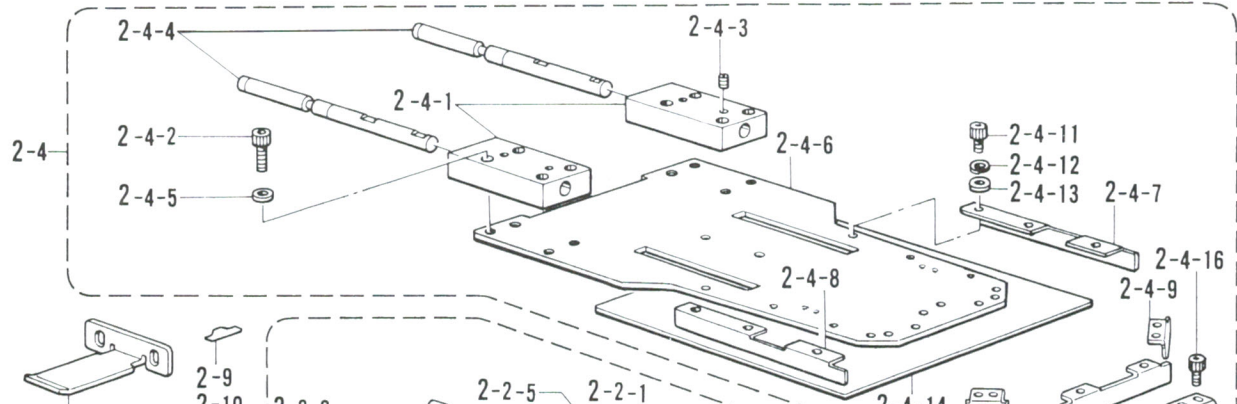
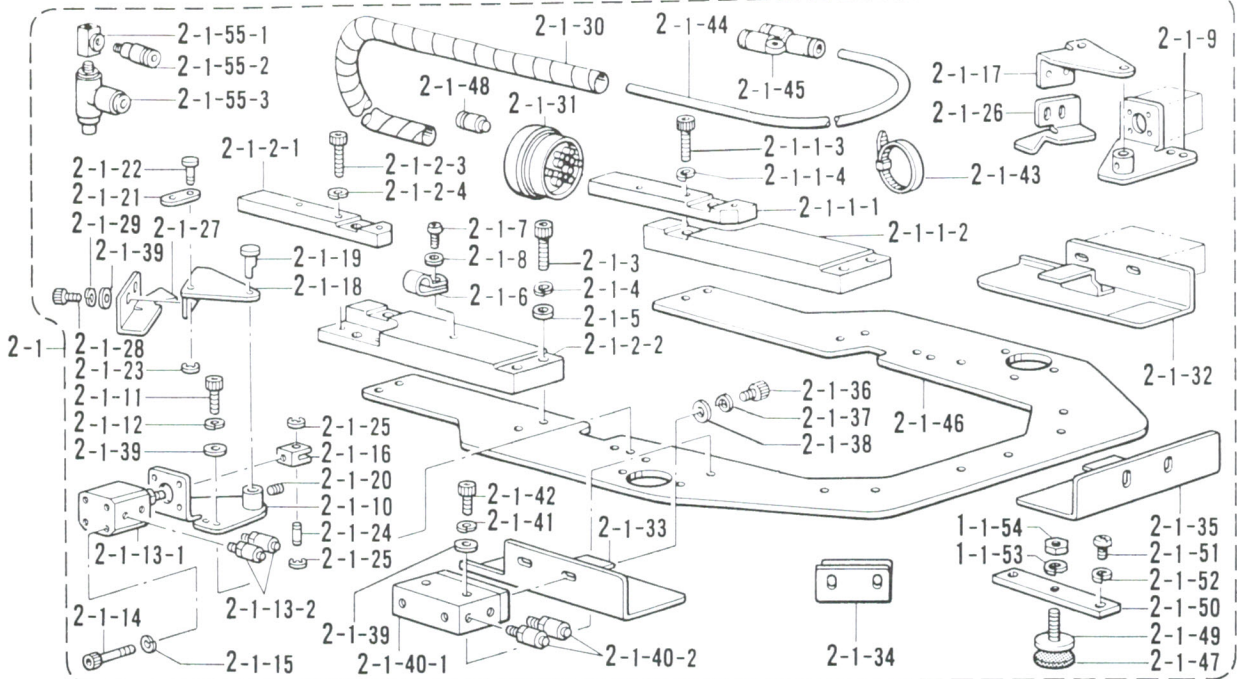

K. 折り曲げ関係 / Folding margin mechanism / Faltungsvorrichtung /
 Mécanisme de marge d'ourlet / Mecanismo de margen de plegado

REF.NO.	CODE	Q'TY	ヒンメイ	NAME OF PARTS	RMKS
2-1-49	S12291001	2	アジ"ヤストネジ"	ADJUST SCREW	
2-1-50	S12294001	2	トリツケイタ(オリササエ)	FITTING PLATE (FOLDING CLAMP)	
2-1-51	062401006	4	ナヘ"コ4X10	SCREW 4X10	
2-1-52	028040243	4	ハ"ネサ"カ"ネ2-4	SPRING WASHER 2-4	
2-1-53	028060243	2	ハ"ネサ"カ"ネ2-6	SPRING WASHER 2-6	
2-1-54	021060206	2	2シユナツト6	NUT 6	
2-1-55	S15564000	1	チ-M5クミ	T-M5 ASSEMBLY	
2-1-55-1	S15563000	1	チ-M5	T-M5	
2-1-55-2	S04905000	1	ハーフェユニオン	HALF UNION	
2-1-55-3	S14328000	2	シボ"リハ"ン	THROTTLE VALVE	
2-2	S24800---	1	ケ"-シ"クミ-5カクJ	CENTER BLADE ASSEMBLY (MITER-J)	
2-2-1	S12107001	2	コネク"ブ"ロツク(GAGE)	CONNECT BLOCK (CENTER BLADE)(GAGE)	
2-2-2	158722002	8	サ"カ"ネ4.2	WASHER 4.2	
2-2-3	018402032	8	アナホ"ルト4X20	BOLT 4X20	
2-2-4	028040242	8	ハ"ネサ"カ"ネ2-4	SPRING WASHER 2-4	
2-2-5	014500522	4	アナトメネシ"5クホ"ミ	SET SCREW 5	
2-2-6	S12108001	2	コネク"ト"ピン(ケ"-シ")	PIN (CENTER BLADE)(GAGE)	
2-2-7	S29183---	1	イタハ"ネR0.8-5カクJ	PLATE SPRING (R-0.8-MITER-J)	
2-2-8	060300414	4	ハ"イント"3X4	SCREW 3X4	
2-2-9	S24801000	1	ケ"-シ"-5カクJ	CENTER BLADE (MITER-J)	
2-2-10	S29184---	1	イタハ"ネL0.8-5カクJ	PLATE SPRING (L-0.8-MITER-J)	
2-2-11	S24802000	2	ウケイタ(ケ"-シ")1.6J	SUPPORT PLATE (CENTER BLADE)(GAGE-1.6J)	
2-3	S24805---	1	オサエクミ-5カクJ	SEWING CLAMP ASSEMBLY (MITER-J)	
2-3-1	S12110001	2	コネク"ト"ブ"ロツク(オサエ)	CONNECT BLOCK (PRESSER)	
2-3-2	018401022	8	アナホ"ルト4X10	BOLT 4X10	
2-3-3	028040242	8	ハ"ネサ"カ"ネ2-4	SPRING WASHER 2-4	
2-3-4	158722002	8	サ"カ"ネ4.2	WASHER 4.2	
2-3-5	S24806---	1	オサエ-5カクJ	SEWING CLAMP (MITER-J)	
2-3-6	S12298000	2	フォーム3X15X1000	FORM 3X15X1000	
2-3-7	S12279000	6	ウケイタ(オサエ)	SUPPORT PLATE (PRESSER)	
2-4	S24807---	1	ナカオサエクミ-5カクJ	INNER CLAMP ASSEMBLY (MITER-J)	
2-4-1	S12113001	2	コネク"ト"ブ"ロツク(ナカ)	CONNECT BLOCK (INNER)	
2-4-2	018502522	8	アナホ"ルト5X25	BOLT 5X25	
2-4-3	014500522	4	アナトメネシ"5クホ"ミ	SET SCREW 5	
2-4-4	S12114001	2	コネク"ト"ピン(ナカ)	PIN (INNER)	
2-4-5	S20246001	8	ヒラサ"カ"ネタ"イ5	PLAIN WASHER 5	
2-4-6	S24827---	1	ナカオサエ-5カクJ	INNER CLAMP (MITER-J)	
2-4-7	S24864---	1	ナカオサエウI1-5カクJ	INNER CLAMP BLADE-1 (MITER-J)	
2-4-8	S24865---	1	ナカオサエウI2-5カクJ	INNER CLAMP BLADE-2 (MITER-J)	
2-4-9	S24866---	2	ナカオサエウI3-5カクJ	INNER CLAMP BLADE-3 (MITER-J)	
2-4-10	S24867---	1	ナカオサエウI4-5カクJ	INNER CLAMP BLADE-4 (MITER-J)	
2-4-11	018300532	12	アナホ"ルト3X5	BOLT 3X5	
2-4-12	028030242	12	ハ"ネサ"カ"ネ2-3	SPRING WASHER 2-3	
2-4-13	025030232	12	ヒラサ"カ"ネチユウ3	PLAIN WASHER 3	
2-4-14	S12117000	1	フォーム2X200X200	FORM 2X200X200	
2-4-15	S12487000	3	オリイタウケ(ナカオサエ)	FOLDING PLATE SUPPORT (INNER CLAMP)	
2-4-16	018300532	6	アナホ"ルト3X5	BOLT 3X5	
2-5	S12111001	3	スリットC	SLIT (C)	
2-6	S12112001	3	スリットD	SLIT (D)	
2-7	062300502	6	ナヘ"コ3X5	SCREW 3X5	
2-8	028030242	6	ハ"ネサ"カ"ネ2-3	SPRING WASHER 2-3	
2-9	S16514000	2	スペ"ー"サ0.05	SPACER 0.05	
2-10	S16513000	2	スペ"ー"サ0.1	SPACER 0.1	
6	S12494000	1	オリイタウケシヨウ	FOLDING PLATE SUPPORT (SMALL)	
10	S24888001	1	コネク"ト"ブ"ロツクRクミ	CONNECT BLOCK (R) ASSEMBLY	
10-1	S24460001	1	コネク"ト"ブ"ロツクR-1	CONNECT BLOCK (R-1)	
10-2	S24461001	1	コネク"ト"ブ"ロツクR-2	CONNECT BLOCK (R-2)	
10-3	018502022	2	アナホ"ルト5X20	BOLT 5X20	
10-4	028050242	2	ハ"ネサ"カ"ネ2-5	SPRING WASHER 2-5	

K. 折り曲げ関係/Folding margin mechanism/Faltungsvorrichtung/
 Mécanisme de marge d'ourlet/Mecanismo de margen de plegado

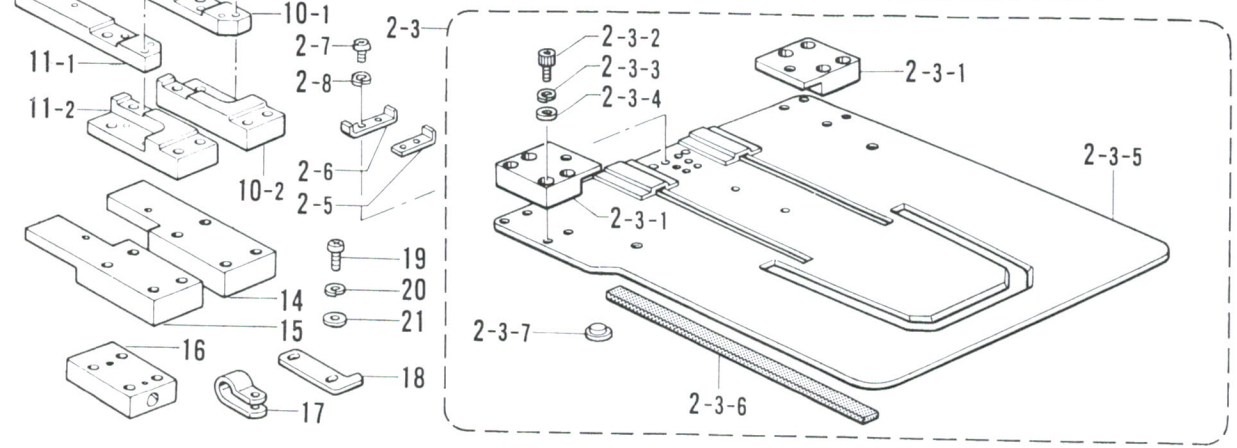
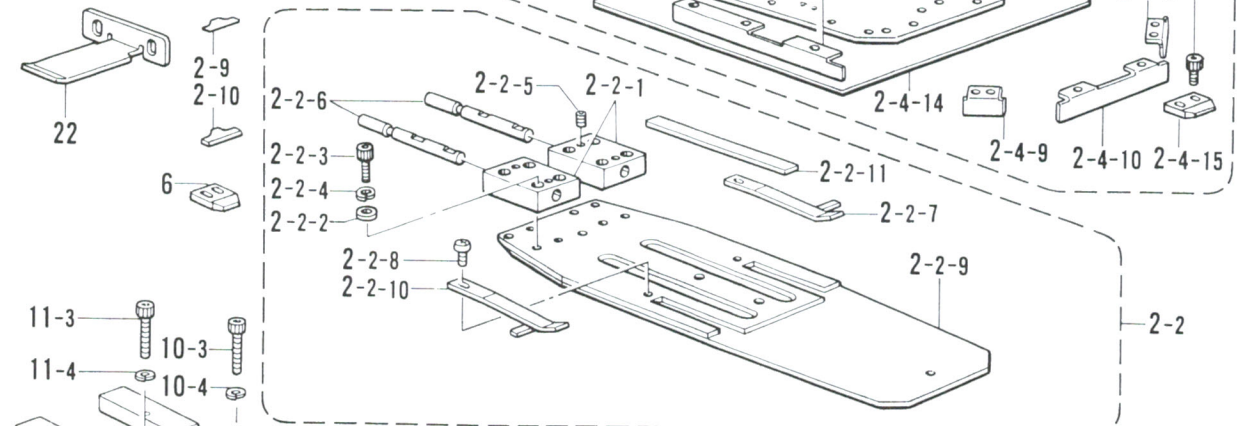
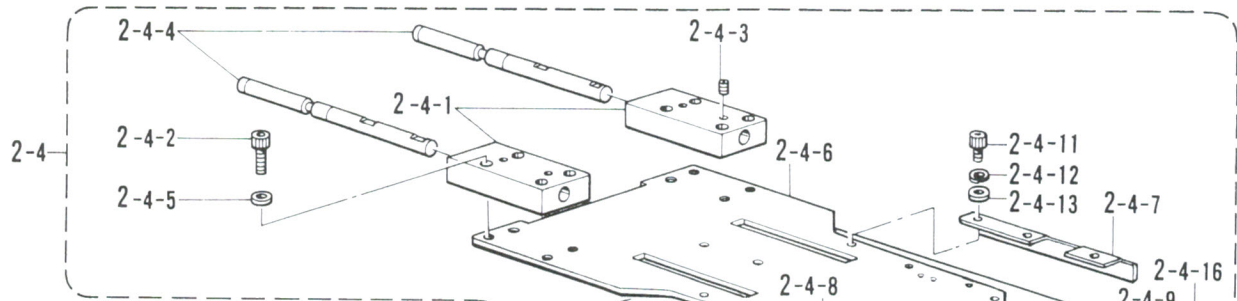
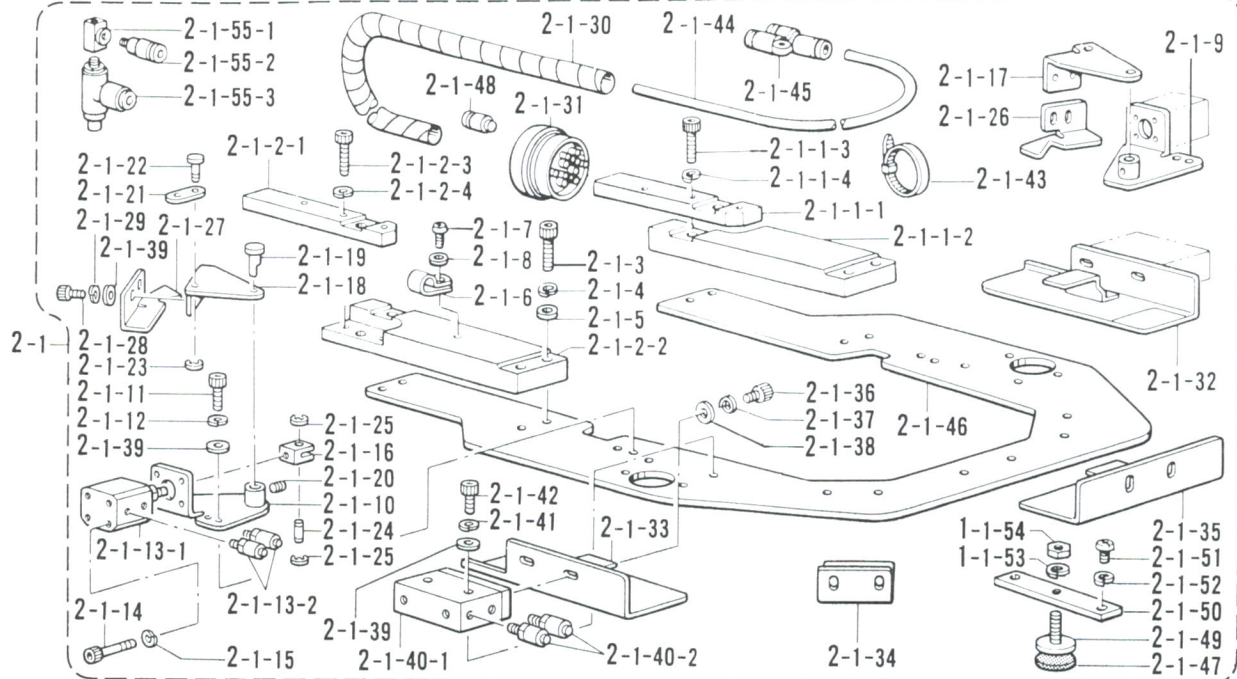

K. 折り曲げ関係/Folding margin mechanism/Faltungsvorrichtung/
Mécánisme de marge d'ourlet/Mecanismo de margen de plegado

REF.NO.	CODE	Q'TY	ヒンメイ	NAME OF PARTS	RMKS
2	S24797---	1	オリキクミ-5カクJ	FOLDING GROUP ASSEMBLY (MITER-J)	
2-1	S24798---	1	オリササエクミ-5カクJ	FOLDING CLAMP ASSEMBLY (MITER-J)	
2-1-1	S24886001	1	コネクタブロックSRクミ	CONNECT BLOCK (SR) ASSEMBLY	
2-1-1-1	S24456001	1	コネクタブロックSR-1	CONNECT BLOCK (SR-1)	
2-1-1-2	S24457001	1	コネクタブロックSR-2	CONNECT BLOCK (SR-2)	
2-1-1-3	018502022	2	アナホルトル5X20	BOLT 5X20	
2-1-1-4	028050242	2	ハ"ネサ"カ"ネ2-5	SPRING WASHER 2-5	
2-1-2	S24887001	1	コネクタブロックSLクミ	CONNECT BLOCK (SL) ASSEMBLY	
2-1-2-1	S24454001	1	コネクタブロックSL-1	CONNECT BLOCK (SL-1)	
2-1-2-2	S24455001	1	コネクタブロックSL-2	CONNECT BLOCK (SL-2)	
2-1-2-3	018502022	2	アナホルトル5X20	BOLT 5X20	
2-1-2-4	028050242	2	ハ"ネサ"カ"ネ2-5	SPRING WASHER 2-5	
2-1-3	018502522	8	アナホルトル5X25	BOLT 5X25	
2-1-4	028050242	8	ハ"ネサ"カ"ネ2-5	SPRING WASHER 2-5	
2-1-5	S20246001	8	ヒラサ"カ"ネタ"イ5	PLAIN WASHER 5	
2-1-6	552907000	1	コートホルタ"10N	CORD HOLDER (10N)	
2-1-7	062401006	1	ナヘ"コ4X10	SCREW 4X10	
2-1-8	025040233	1	ヒラサ"カ"ネチユウ4	PLAIN WASHER 4	
2-1-9	S24783001	1	メントリ"タ"イRJ	TUCKING BASE (RJ)	
2-1-10	S24784001	1	メントリ"タ"イLJ	TUCKING BASE (LJ)	
2-1-11	018400832	4	アナホルトル4X8	BOLT 4X8	
2-1-12	028040242	4	ハ"ネサ"カ"ネ2-4	SPRING WASHER 2-4	
2-1-13	S12090000	2	シリンタ"-12X10クミ	CYLINDER 12X10 ASSEMBLY	
2-1-13-1	S12091000	2	シリンタ"-12X10	CYLINDER 12X10	
2-1-13-2	S11433000	4	ホースニツプ"ル4M5	HOSE NIPPLE 4M5	
2-1-14	S12092000	8	CQ2ホルトルM3X30	CQ2 BOLT M3X30	
2-1-15	028030243	8	ハ"ネサ"カ"ネ2-3	SPRING WASHER 2-3	
2-1-16	S12093001	2	ナツクル	KNUCKLE	
2-1-17	S24785000	1	メントリヒンシ"RJ	HINGE (RJ)	
2-1-18	S24786000	1	メントリヒンシ"LJ	HINGE (LJ)	
2-1-19	S12096001	2	ヒンシ"ヒ"ン	PIN	
2-1-20	014400522	2	アナクホ"ミ4X5	SET SCREW 4X5	
2-1-21	S12097001	2	タイフ"レート	TIE PLATE	
2-1-22	S12098001	2	ヒ"ン	PIN	
2-1-23	048050342	2	トメフE5	STOP RING E5	
2-1-24	S12099001	2	ナツクルヒ"ン	PIN	
2-1-25	048050342	4	トメフE5	STOP RING E5	
2-1-26	S24787000	1	メントリイタRJ	TUCKING BLADE (RJ)	
2-1-27	S24788000	1	メントリイタLJ	TUCKING BLADE (LJ)	
2-1-28	018400632	4	アナホルトル4X6	BOLT 4X6	
2-1-29	028040242	4	ハ"ネサ"カ"ネ2-4	SPRING WASHER 2-4	
2-1-30	S12214000	1	スパ"イラル640L	SPIRAL 640L	
2-1-31	S12106000	1	マルチコネクタP	MULTI CONNECTOR (P)	
2-1-32	S24845---	1	オリイタR-5カクJ	TUCKING BLADE (R-MITER-J)	
2-1-33	S24846---	1	オリイタL-5カクJ	TUCKING BLADE (L-MITER-J)	
2-1-34	S24847---	2	オリイタS-5カクJ	TUCKING BLADE (S-MITER-J)	
2-1-35	S24848---	1	オリイタM-5カクJ	TUCKING BLADE (M-MITER-J)	
2-1-36	018500822	10	アナホルトル5X8	BOLT 5X8	
2-1-37	028050242	10	ハ"ネサ"カ"ネ2-5	SPRING WASHER 2-5	
2-1-38	S20246001	10	ヒラサ"カ"ネタ"イ5	PLAIN WASHER 5	
2-1-39	158722002	18	サ"カ"ネ4.2	WASHER 4.2	
2-1-40	S24789000	5	ツインロツト"シリンタ"-クミ	TWIN ROD CYLINDER ASSEMBLY	
2-1-40-1	S24790000	5	ツインロツト"シリンタ"-20	TWIN ROD CYLINDER 20	
2-1-40-2	S11433000	10	ホースニツプ"ル4M5	HOSE NIPPLE 4M5	
2-1-41	028040242	10	ハ"ネサ"カ"ネ2-4	SPRING WASHER 2-4	
2-1-42	018403022	10	アナホルトル4X30	BOLT 4X30	
2-1-43	S04159000	4	バンド"1M	BAND 1M	
2-1-44	S12205000	1	エアホ-ス4X2.5-29	AIR TUBE 4X2.5-29 (L=7500)	
2-1-45	S12104000	8	ユニオンワイ4	UNION-Y 4	
2-1-46	S24799---	1	オリササエ-5カクJ	FOLDING CLAMP(MITER-J)	
2-1-47	S12297000	2	スポンジ"2-30	SPONGE 2-30	
2-1-48	S19555000	2	キャツプ4	CAP 4	

K. 折り曲げ関係/Folding margin mechanism/Faltungsvorrichtung/
 Mécanisme de marge d'ourlet/Mecanismo de margen de plegado

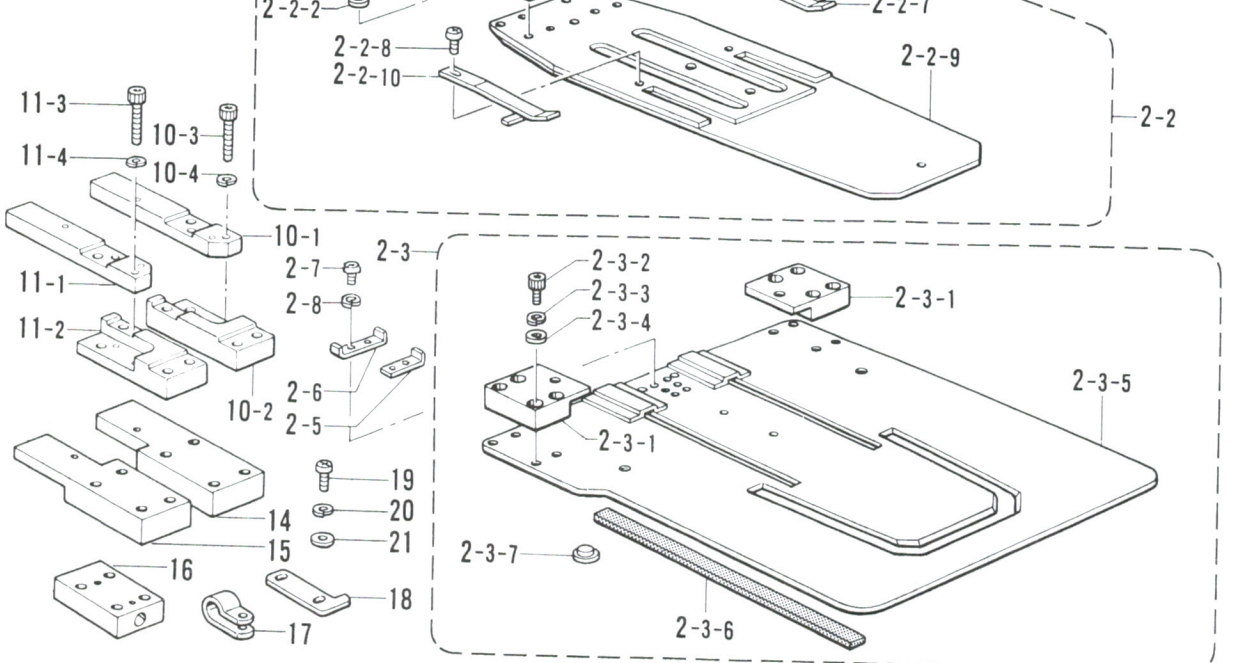
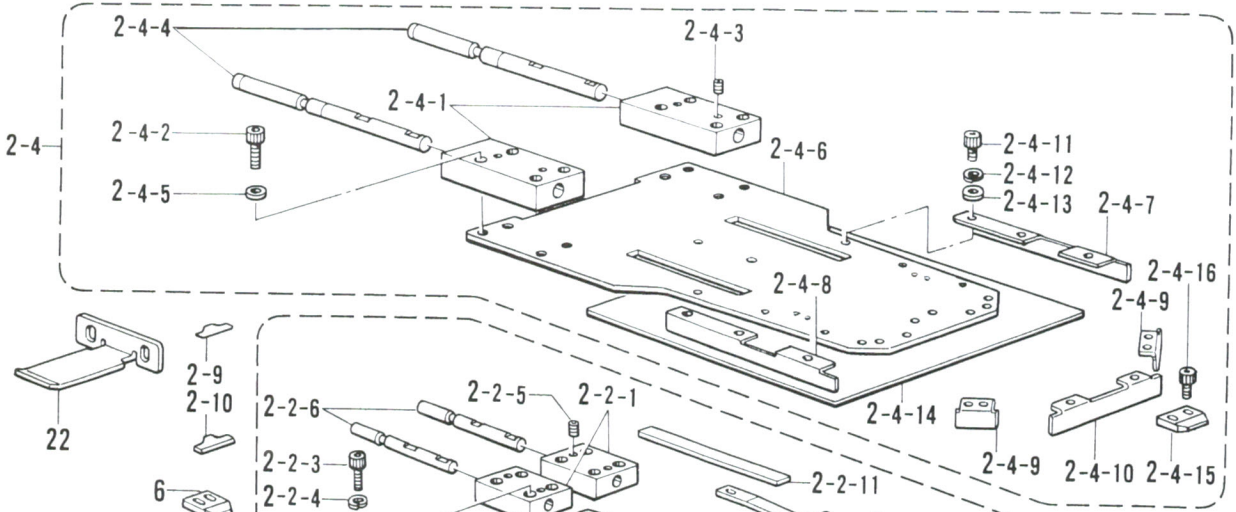
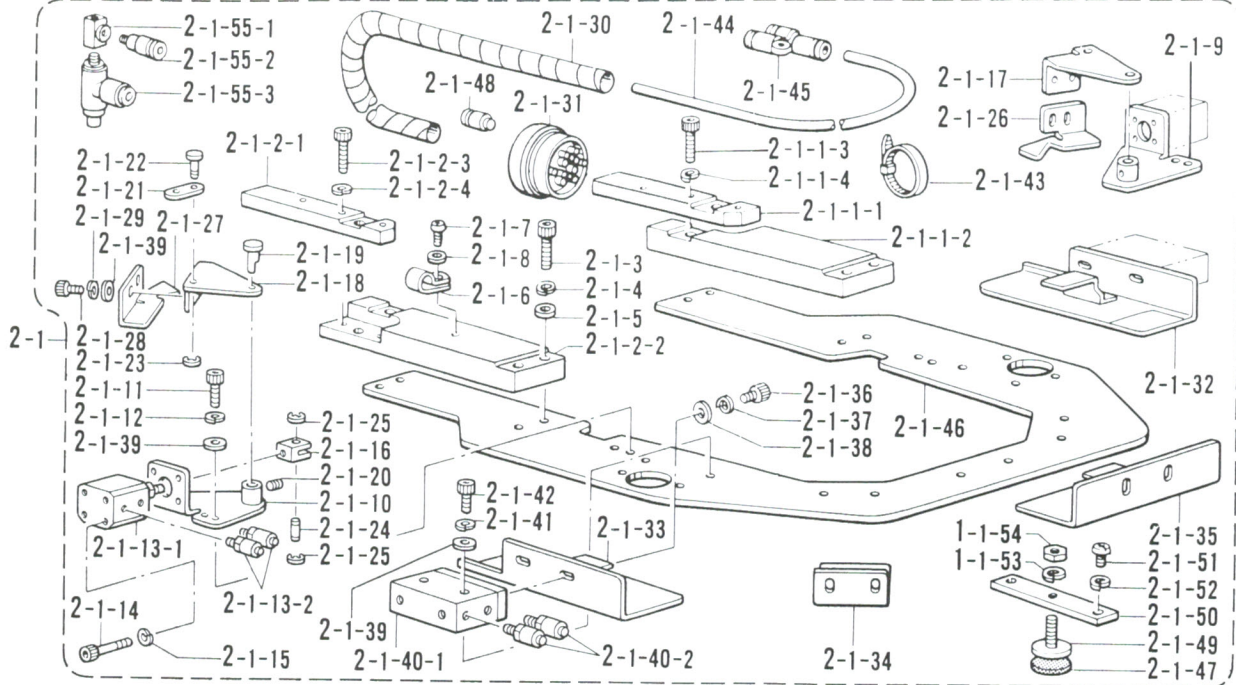

K. 折り曲げ関係/Folding margin mechanism/Faltungsvorrichtung/
 Mécanisme de marge d'ourlet/Mecanismo de margen de plegado

REF.NO.	CODE	Q'TY	ヒンメイ	NAME OF PARTS	RMKS
14	S21121001	1	コネクタブロックSSR	CONNECT BLOCK (SSR)	
15	S21122001	1	コネクタブロックSSL	CONNECT BLOCK (SSL)	
16	S21123001	2	コネクタブロックS	CONNECT BLOCK (S)	
17	S24828000	1	クランプリング12	CLAMP RING 12	
18	S24890001	1	イチキ"メータ(ラベルソウチ)	POSITIONING PLATE (LABEL DEVICE)	
19	062400616	2	ナヘ"COM4X6	SCREW 4X6	
20	028040243	2	ハ"ネサ"ガ"ネ2-4	SPRING WASHER 2-4	
21	025040233	2	ヒラサ"ガ"ネチユウ4	PLAIN WASHER 4	
22	S24893000	1	オリタウエJ	FOLDING PLATE UPPER (J)	

K. 折り曲げ関係/Folding margin mechanism/Faltungsvorrichtung/
 Mécanisme de marge d'ourlet/Mecanismo de margen de plegado

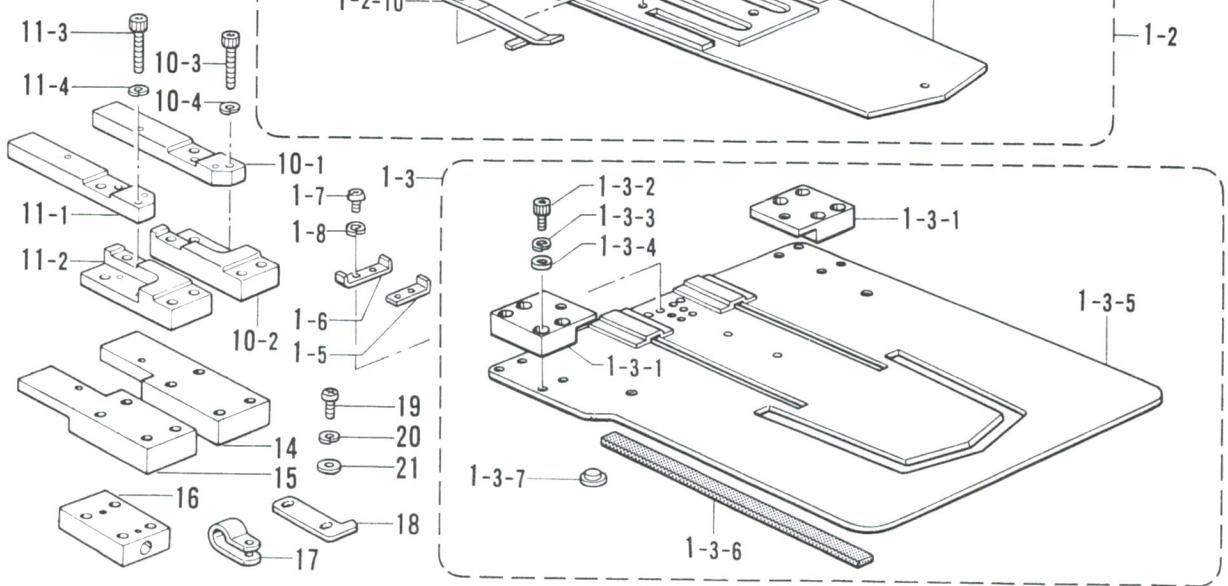
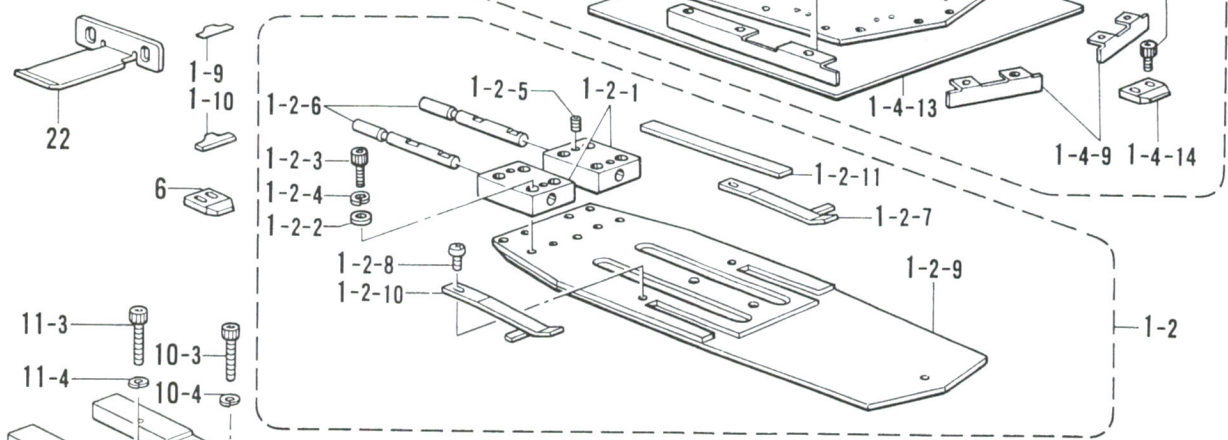
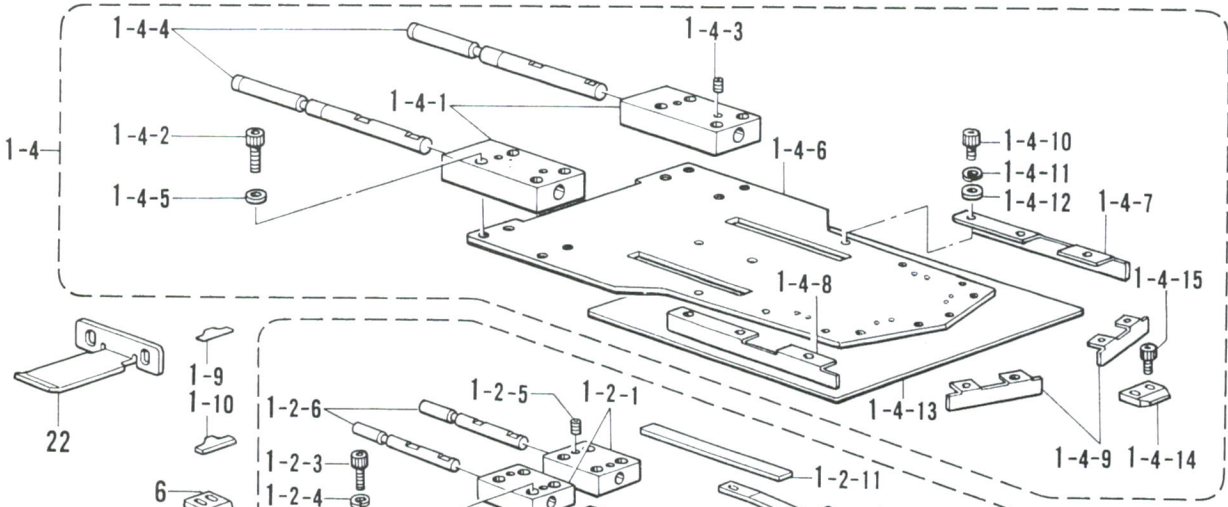
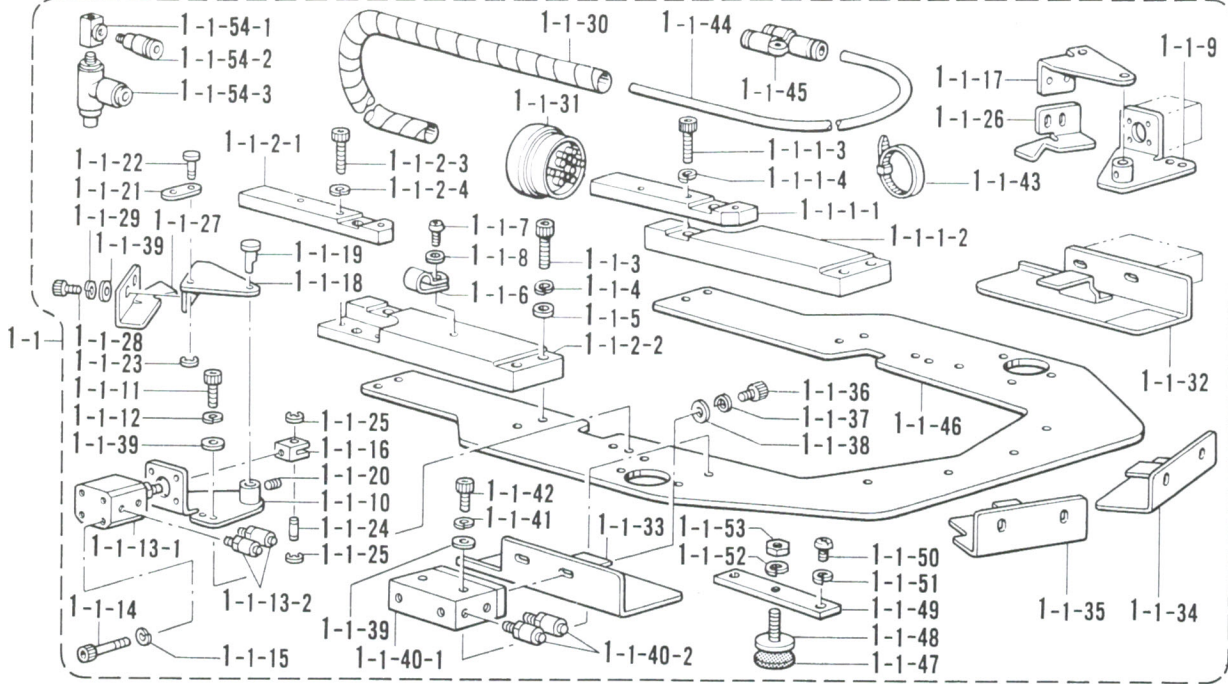

K. 折り曲げ関係 / Folding margin mechanism / Faltungsvorrichtung /
Mécanisme de marge d'ourlet / Mecanismo de margen de plegado

REF.NO.	CODE	Q'TY	ヒンメイ	NAME OF PARTS	RMKS
1-1-49	S12294001	2	トリツケイタ(オリササエ)	FITTING PLATE (FOLDING CLAMP)	
1-1-50	062401006	4	ナヘ"コ4X10	SCREW 4X10	
1-1-51	028040243	4	ハ"ネサ"カ"ネ2-4	SPRING WASHER 2-4	
1-1-52	028060243	2	ハ"ネサ"カ"ネ2-6	SPRING WASHER 2-6	
1-1-53	021060206	2	2シユナツト6	NUT 6	
1-1-54	S15564000	1	チ-M5クミ	T-M5 ASSEMBLY	
1-1-54-1	S15563000	1	チ-M5	T-M5	
1-1-54-2	S04905000	1	ハーフユニオン	HALF UNION	
1-1-54-3	S14328000	2	シホ"リハ"ン	THROTTLE VALVE	
1-2	S24792---	1	ケ-シ"クミ-3カクJ	CENTER BLADE ASSEMBLY (TRIANGLE-J)	
1-2-1	S12107001	2	コネクトフ"ロツク(GAGE)	CONNECT BLOCK (CENTER BLADE)(GAGE)	
1-2-2	158722002	8	サ"カ"ネ4.2	WASHER 4.2	
1-2-3	018402032	8	アナホ"ルト4X20	BOLT 4X20	
1-2-4	028040242	8	ハ"ネサ"カ"ネ2-4	SPRING WASHER 2-4	
1-2-5	014500522	4	アナトメネシ"5クホ"ミ	SET SCREW 5	
1-2-6	S12108001	2	コネクトピン(ケ-シ")	PIN (CENTER BLADE)(GAGE)	
1-2-7	S29181---	1	イタハ"ネR0.8-3カクJ	PLATE SPRING (R-0.8-TRIANGLE-J)	
1-2-8	060300414	4	ハ"イント"3X4	SCREW 3X4	
1-2-9	S24793---	1	ケ-シ"-3カクJ	CENTER BLADE (TRIANGLE-J)	
1-2-10	S29182---	1	イタハ"ネL0.8-3カクJ	PLATE SPRING (L-0.8-TRIANGLE-J)	
1-2-11	S24802000	2	ウケイタ(ケ-シ")1.6J	SUPPORT PLATE (CENTER BLADE)(GAGE-1.6J)	
1-3	S24794---	1	オサエクミ-3カクJ	SEWING CLAMP ASSEMBLY (TRIANGLE-J)	
1-3-1	S12110001	2	コネクトフ"ロツク(オサエ)	CONNECT BLOCK (PRESSER)	
1-3-2	018401022	8	アナホ"ルト4X10	BOLT 4X10	
1-3-3	028040242	8	ハ"ネサ"カ"ネ2-4	SPRING WASHER 2-4	
1-3-4	158722002	8	サ"カ"ネ4.2	WASHER 4.2	
1-3-5	S24795---	1	オサエ-3カクJ	SEWING CLAMP (TRIANGLE-J)	
1-3-6	S12298000	2	フォーム3X15X1000	FORM 3X15X1000	
1-3-7	S12279000	6	ウケイタ(オサエ)	SUPPORT PLATE (PRESSER)	
1-4	S24796---	1	ナカオサエクミ-3カクJ	INNER CLAMP ASSEMBLY (TRIANGLE-J)	
1-4-1	S12113001	2	コネクトフ"ロツク(ナカ)	CONNECT BLOCK (INNER)	
1-4-2	018502522	8	アナホ"ルト5X25	BOLT 5X25	
1-4-3	014500522	4	アナトメネシ"5クホ"ミ	SET SCREW 5	
1-4-4	S12114001	2	コネクトピン(ナカ)	PIN (INNER)	
1-4-5	S20246001	8	ヒラサ"カ"ネダ"イ5	PLAIN WASHER 5	
1-4-6	S24826---	1	ナカオサエ-3カクJ	INNER CLAMP (TRIANGLE-J)	
1-4-7	S24861---	1	ナカオサエウエ1-3カクJ	INNER CLAMP BLADE-1 (TRIANGLE-J)	
1-4-8	S24862---	1	ナカオサエウエ2-3カクJ	INNER CLAMP BLADE-2 (TRIANGLE-J)	
1-4-9	S24863---	2	ナカオサエウエ3-3カクJ	INNER CLAMP BLADE-3 (TRIANGLE-J)	
1-4-10	018300532	10	アナホ"ルト3X5	BOLT 3X5	
1-4-11	028030242	10	ハ"ネサ"カ"ネ2-3	SPRING WASHER 2-3	
1-4-12	025030232	10	ヒラサ"カ"ネチユウ3	PLAIN WASHER 3	
1-4-13	S12117000	1	フォーム2X200X200	FORM 2X200X200	
1-4-14	S12487000	4	オリイタウケ(ナカオサエ)	FOLDING PLATE SUPPORT (INNER CLAMP)	
1-4-15	018300532	8	アナホ"ルト3X5	BOLT 3X5	
1-5	S12111001	3	スリットC	SLIT (C)	
1-6	S12112001	3	スリットD	SLIT (D)	
1-7	062300502	6	ナヘ"コ3X5	SCREW 3X5	
1-8	028030242	6	ハ"ネサ"カ"ネ2-3	SPRING WASHER 2-3	
1-9	S16514000	2	スヘ-サ0.05	SPACER 0.05	
1-10	S16513000	2	スヘ-サ0.1	SPACER 0.1	
6	S12494000	1	オリイタウケシヨウ	FOLDING PLATE SUPPORT (SMALL)	
10	S24888001	1	コネクトフ"ロツクRクミ	CONNECT BLOCK (R) ASSEMBLY	
10-1	S24460001	1	コネクトフ"ロツクR-1	CONNECT BLOCK (R-1)	
10-2	S24461001	1	コネクトフ"ロツクR-2	CONNECT BLOCK (R-2)	
10-3	018502022	2	アナホ"ルト5X20	BOLT 5X20	
10-4	028050242	2	ハ"ネサ"カ"ネ2-5	SPRING WASHER 2-5	
11	S24889001	1	コネクトフ"ロツクLクミ	CONNECT BLOCK (L) ASSEMBLY	
11-1	S24458001	1	コネクトフ"ロツクL-1	CONNECT BLOCK (L-1)	
11-2	S24459001	1	コネクトフ"ロツクL-2	CONNECT BLOCK (L-2)	
11-3	018502022	2	アナホ"ルト5X20	BOLT 5X20	
11-4	028050242	2	ハ"ネサ"カ"ネ2-5	SPRING WASHER 2-5	

K. 折り曲げ関係/Folding margin mechanism/Faltungsvorrichtung/
 Mécanisme de marge d'ourlet/Mecanismo de margen de plgado

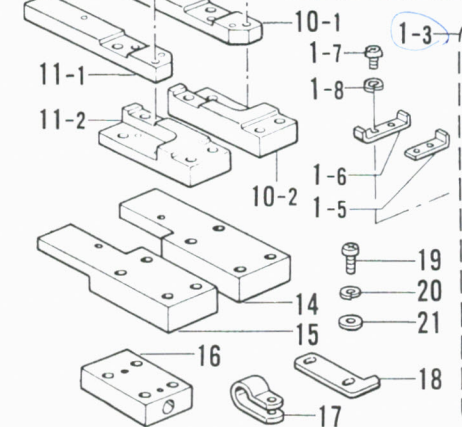
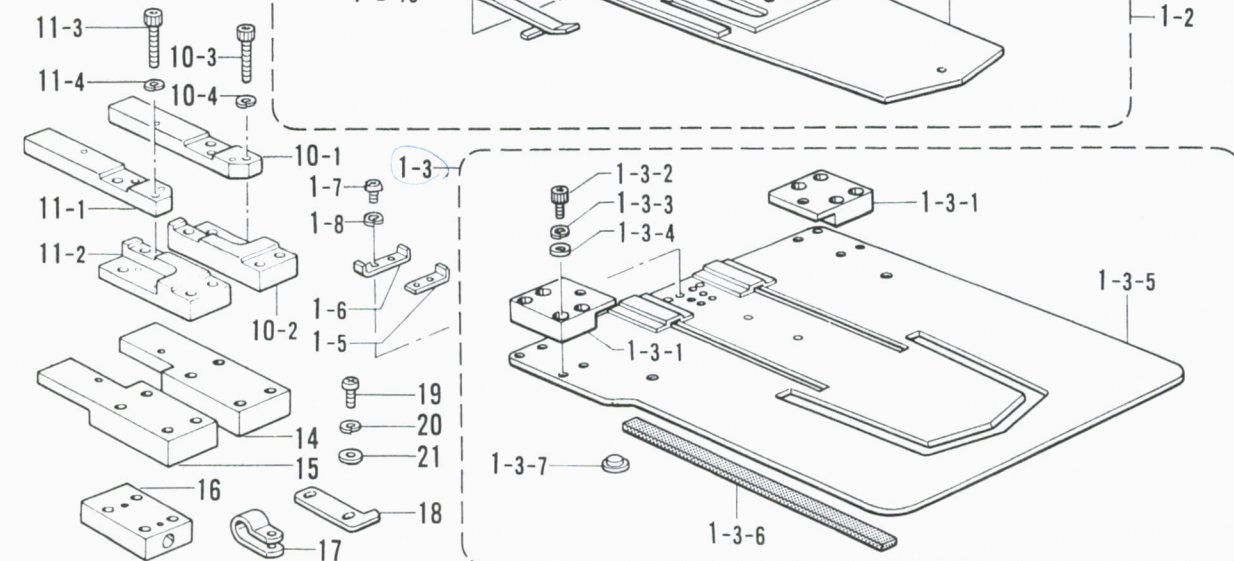
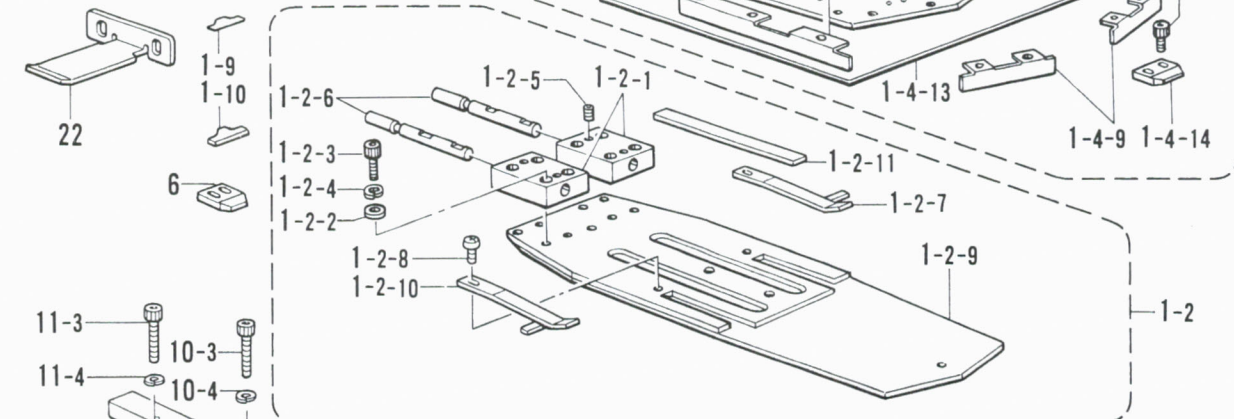
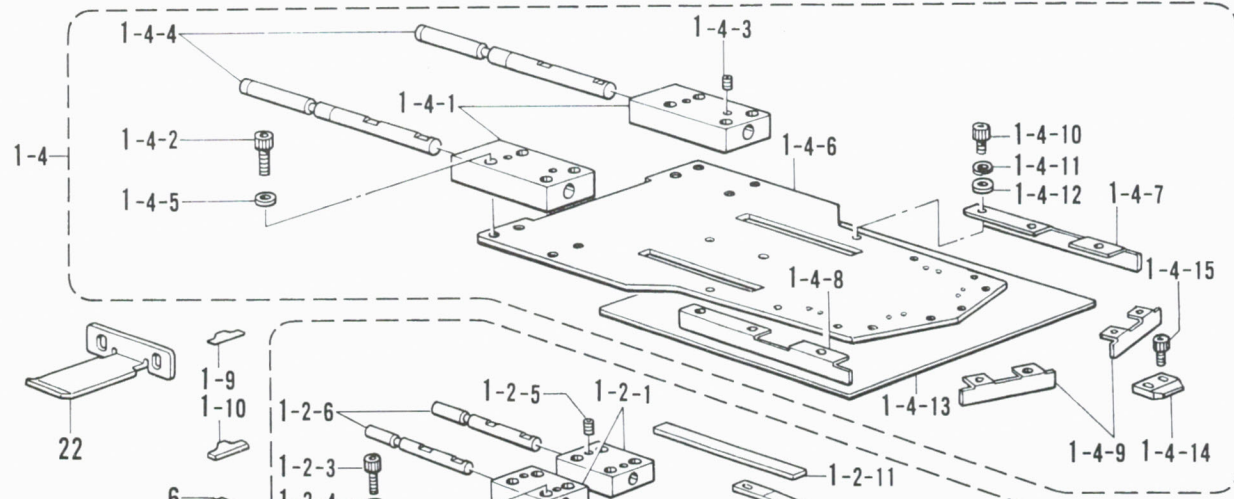
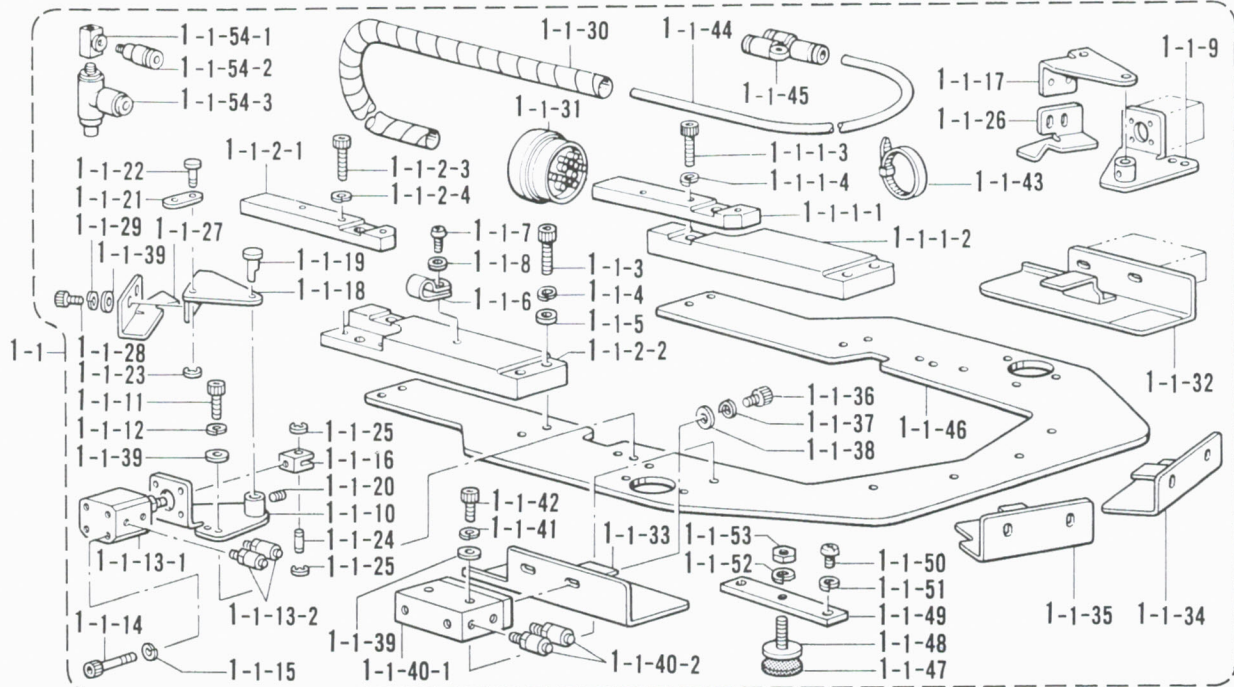

K. 折り曲げ関係 / Folding margin mechanism / Faltungsvorrichtung /
Mécanisme de marge d'ourlet / Mecanismo de margen de plegado

REF.NO.	CODE	Q'TY	ヒンメイ	NAME OF PARTS	RMKS
1	S24781---	1	オリキクミ-3カクJ	FOLDING GROUP ASSEMBLY (TRIANGLE-J)	
1-1	S24782---	1	オリササエクミ-3カクJ	FOLDING CLAMP ASSEMBLY (TRIANGLE-J)	
1-1-1	S24886001	1	コネクタブ"ロックSRクミ	CONNECT BLOCK (SR) ASSEMBLY	
1-1-1-1	S24456001	1	コネクタブ"ロックSR-1	CONNECT BLOCK (SR-1)	
1-1-1-2	S24457001	1	コネクタブ"ロックSR-2	CONNECT BLOCK (SR-2)	
1-1-1-3	018502022	2	アナホ"ルト5X20	BOLT 5X20	
1-1-1-4	028050242	2	ハ"ネサ"カ"ネ2-5	SPRING WASHER 2-5	
1-1-2	S24887001	1	コネクタブ"ロックSLクミ	CONNECT BLOCK (SL) ASSEMBLY	
1-1-2-1	S24454001	1	コネクタブ"ロックSL-1	CONNECT BLOCK (SL-1)	
1-1-2-2	S24455001	1	コネクタブ"ロックSL-2	CONNECT BLOCK (SL-2)	
1-1-2-3	018502022	2	アナホ"ルト5X20	BOLT 5X20	
1-1-2-4	028050242	2	ハ"ネサ"カ"ネ2-5	SPRING WASHER 2-5	
1-1-3	018502522	8	アナホ"ルト5X25	BOLT 5X25	
1-1-4	028050242	8	ハ"ネサ"カ"ネ2-5	SPRING WASHER 2-5	
1-1-5	S20246001	8	ヒラサ"カ"ネタ"イ5	PLAIN WASHER 5	
1-1-6	552907000	1	コート"ホルタ"10N	CORD HOLDER (10N)	
1-1-7	062401006	1	ナヘ"コ4X10	SCREW 4X10	
1-1-8	025040233	1	ヒラサ"カ"ネチユウ4	PLAIN WASHER 4	
1-1-9	S24783001	1	メントリ"タ"イRJ	TUCKING BASE (RJ)	
1-1-10	S24784001	1	メントリ"タ"イLJ	TUCKING BASE (LJ)	
1-1-11	018400832	4	アナホ"ルト4X8	BOLT 4X8	
1-1-12	028040242	4	ハ"ネサ"カ"ネ2-4	SPRING WASHER 2-4	
1-1-13	S12090000	2	シリンダ"-12X10クミ	CYLINDER 12X10 ASSEMBLY	
1-1-13-1	S12091000	2	シリンダ"-12X10	CYLINDER 12X10	
1-1-13-2	S11433000	4	ホースニツプル4M5	HOSE NIPPLE 4M5	
1-1-14	S12092000	8	CQ2ホ"ルトM3X30	CQ2 BOLT M3X30	
1-1-15	028030243	8	ハ"ネサ"カ"ネ2-3	SPRING WASHER 2-3	
1-1-16	S12093001	2	ナツクル	KNUCKLE	
1-1-17	S24785000	1	メントリ"ヒンシ"RJ	HINGE (RJ)	
1-1-18	S24786000	1	メントリ"ヒンシ"LJ	HINGE (LJ)	
1-1-19	S12096001	2	ヒンシ"ヒン	PIN	
1-1-20	014400522	2	アナクホ"ミ4X5	SET SCREW 4X5	
1-1-21	S12097001	2	タイプレート	TIE PLATE	
1-1-22	S12098001	2	ピン	PIN	
1-1-23	048050342	2	トメフE5	STOP RING E5	
1-1-24	S12099001	2	ナツクルピン	PIN	
1-1-25	048050342	4	トメフE5	STOP RING E5	
1-1-26	S24787000	1	メントリ"イタRJ	TUCKING BLADE (RJ)	
1-1-27	S24788000	1	メントリ"イタLJ	TUCKING BLADE (LJ)	
1-1-28	018400632	4	アナホ"ルト4X6	BOLT 4X6	
1-1-29	028040242	4	ハ"ネサ"カ"ネ2-4	SPRING WASHER 2-4	
1-1-30	S12214000	1	スパイラル640L	SPIRAL 640L	
1-1-31	S12106000	1	マルチコネクタP	MULTI CONNECTOR (P)	
1-1-32	S24841---	1	オリイタR-3カクJ	TUCKING BLADE (R)(TRIANGLE-J)	
1-1-33	S24842---	1	オリイタL-3カクJ	TUCKING BLADE (L)(TRIANGLE-J)	
1-1-34	S24843---	1	オリイタRD-3カクJ	TUCKING BLADE (RD)(TRIANGLE-J)	
1-1-35	S24844---	1	オリイタLD-3カクJ	TUCKING BLADE (LD)(TRIANGLE-J)	
1-1-36	018500822	8	アナホ"ルト5X8	BOLT 5X8	
1-1-37	028050242	8	ハ"ネサ"カ"ネ2-5	SPRING WASHER 2-5	
1-1-38	S20246001	8	ヒラサ"カ"ネタ"イ5	PLAIN WASHER 5	
1-1-39	158722002	16	サ"カ"ネ4.2	WASHER 4.2	
1-1-40	S24789000	4	ツインロッド"シリンダ"-クミ	TWIN ROD CYLINDER ASSEMBLY	
1-1-40-1	S24790000	4	ツインロッド"シリンダ"-20	TWIN ROD CYLINDER 20	
1-1-40-2	S11433000	8	ホースニツプル4M5	HOSE NIPPLE 4M5	
1-1-41	028040242	8	ハ"ネサ"カ"ネ2-4	SPRING WASHER 2-4	
1-1-42	018403022	8	アナホ"ルト4X30	BOLT 4X30	
1-1-43	S04159000	4	バンド"1M	BAND 1M	
1-1-44	S12205000	1	エアホース4X2.5-29	AIR TUBE 4X2.5-29 (L=7500)	
1-1-45	S12104000	4	ユニオンワイ4	UNION-Y 4	
1-1-46	S24791---	1	オリササエ-3カクJ	FOLDING CLAMP (TRIANGLE-J)	
1-1-47	S12297000	2	スポンジ"2-30	SPONGE 2-30	
1-1-48	S12291001	2	アジ"ヤストネジ"	ADJUST SCREW	

K. 折り曲げ関係 / Folding margin mechanism / Faltungsvorrichtung /
 Mécanisme de marge d'ourlet / Mecanismo de margen de plegado

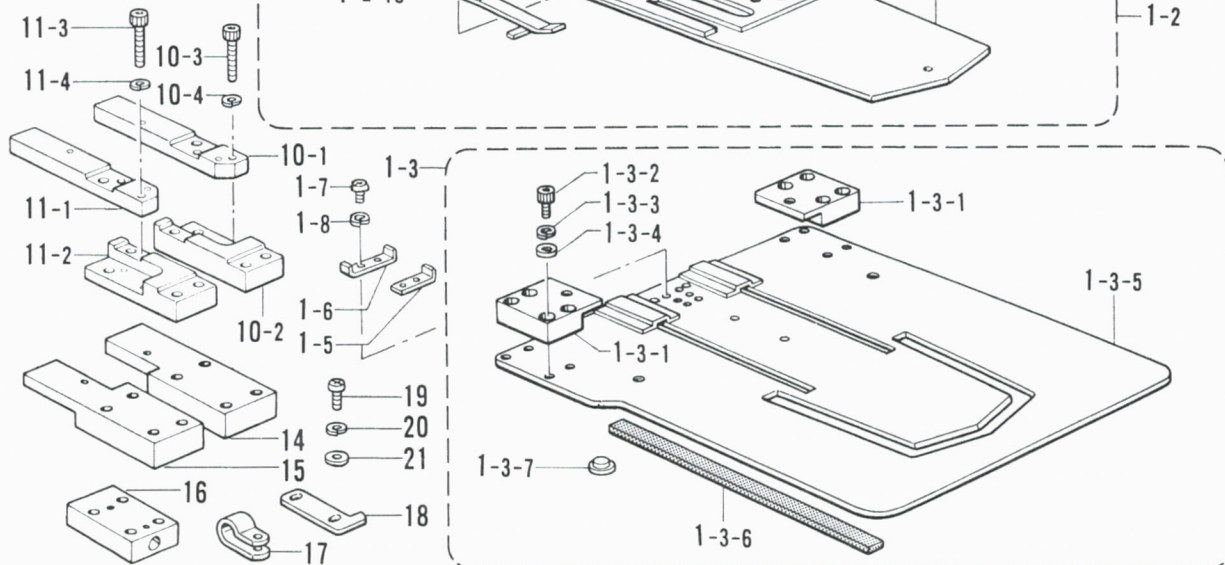
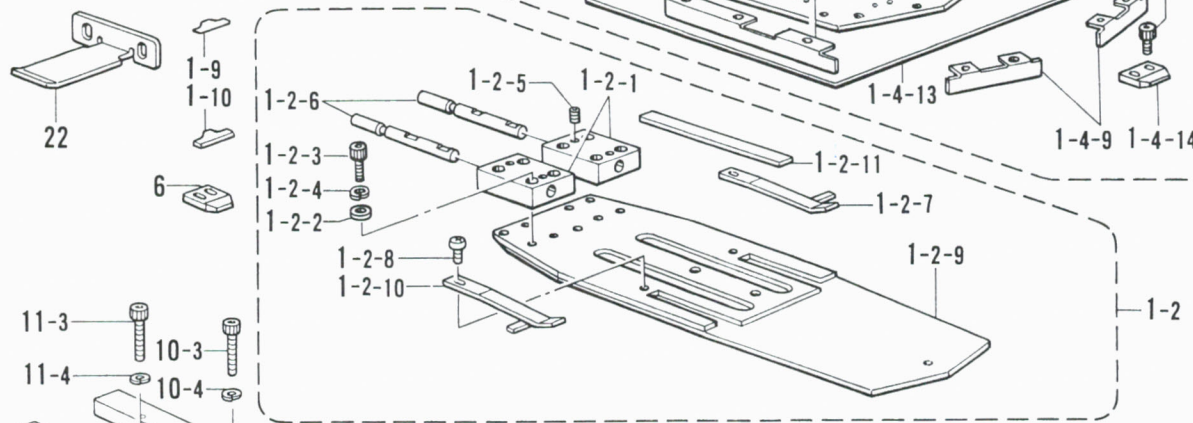
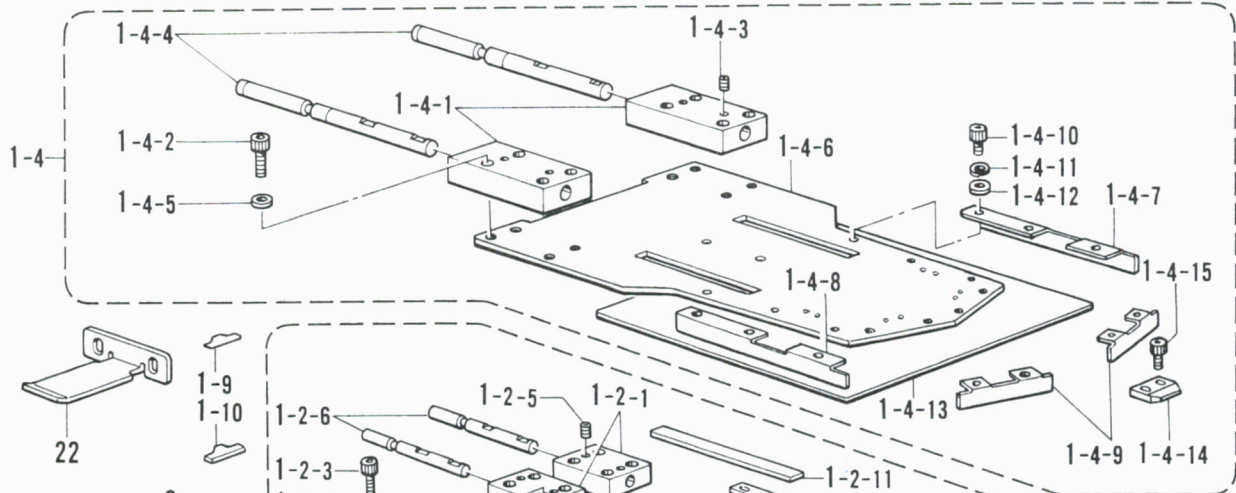
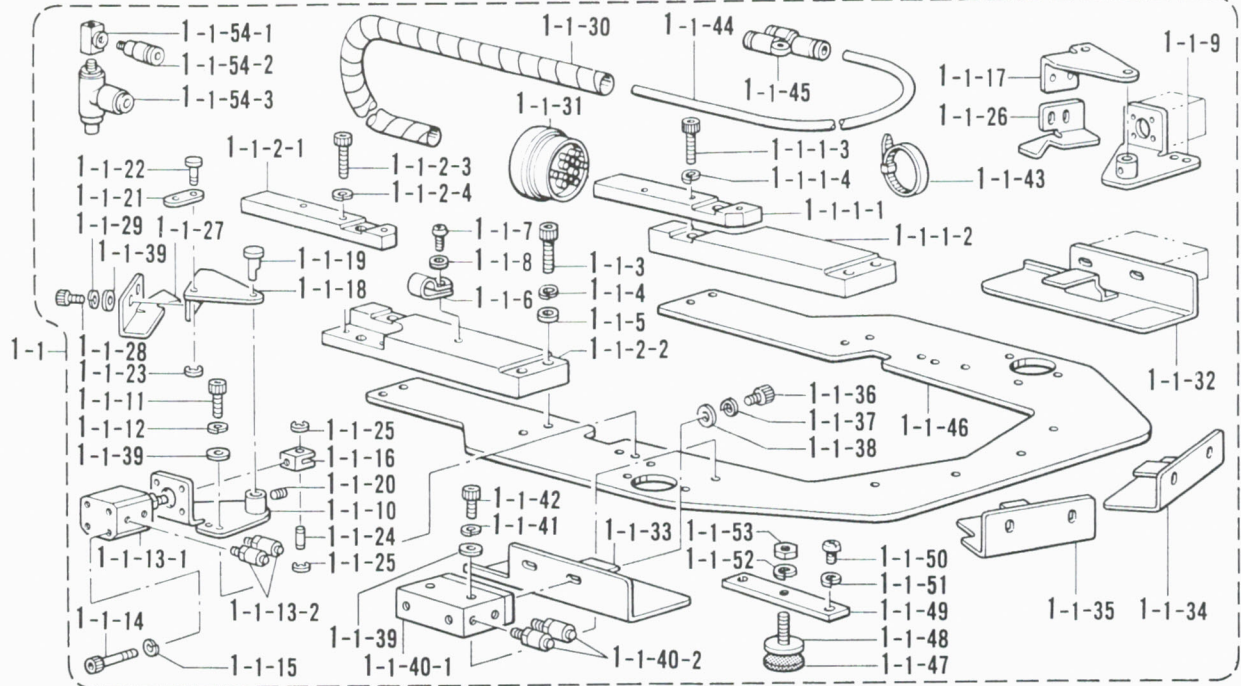

J. 送り案内関係/Feed guide mechanism/Transportführung/
 Mécanisme du guide de l'entraînement/Mecanismo de la guía de alimentación

REF.NO.	CODE	Q'TY	ヒンメイ	NAME OF PARTS	RMKS
1	S12063009	2	モーターササエ	MOTOR SUPPORT	
2	018062022	8	アナホ"ルト6X20	BOLT 6X20	
3	028060242	8	ハ"ネサ"カ"ネ2-6	SPRING WASHER 2-6	
4	076002450	4	タマシ"クウケ6002DD	BALL BEARING 6002DD	
5	S12065000	1	プーリー"シ"クA	PULLEY SHAFT (A)	
6	S12066000	1	プーリー"シ"クB	PULLEY SHAFT (B)	
7	S12067000	4	キー	KEY	
8	S12068001	2	キ"ヤササエ	GEAR SUPPORT	
9	S12069000	2	ナイロンキ"ヤ	NYLON GEAR	
10	014060632	2	アナトメ6X6クホ"ミ	SET SCREW 6X6	
11	S12070000	2	キ"ヤ	GEAR	
12	014060632	4	アナトメ6X6クホ"ミ	SET SCREW 6X6	
13	S23403001	1	シヤフトササエミキ"	SHAFT SUPPORT RIGHT	
14	S23404001	1	シヤフトササエヒタ"リ	SHAFT SUPPORT LEFT	
15	018063022	8	アナホ"ルト6X30	BOLT 6X30	
16	028060242	8	ハ"ネサ"カ"ネ2-6	SPRING WASHER 2-6	
17	S24767001	2	LMシヤフト25	LM SHAFT 25	
18	150949001	4	ナカオサエチヨウセツネシ"	ADJUST SCREW	
19	S12074000	2	プーリーB	PULLEY (B)	
20	014060632	2	アナトメ6X6クホ"ミ	SET SCREW 6X6	
21	S12075002	2	プーリーササエA	PULLEY SUPPORT (A)	
22	S12076000	2	プーリー"シ"クD	PULLEY SHAFT (D)	
23	S12077000	2	プーリーA	PULLEY (A)	
24	S12078000	4	フカミゾ"タマシ"クウケ2	DEEP GROOVE BALL BEARING 2	
25	S12079000	4	カラー2	COLLAR 2	
26	S24768000	1	タイミンク"へ"ルトA	TIMING BELT (A)	
27	S12081000	1	タイミンク"へ"ルトB	TIMING BELT (B)	
28	018062022	4	アナホ"ルト6X20	BOLT 6X20	
29	025060232	4	ヒラサ"カ"ネチユウ6	PLAIN WASHER 6	
30	028060242	4	ハ"ネサ"カ"ネ2-6	SPRING WASHER 2-6	
31	018063022	2	アナホ"ルト6X30	BOLT 6X30	
32	S12082000	2	リニアガ"イト"	LINEAR GUIDE	
33	018401622	16	アナホ"ルト4X16	BOLT 4X16	
34	028040242	16	ハ"ネサ"カ"ネ2-4	SPRING WASHER 2-4	
35	S24769001	1	カハ"ーササエ	COVER SUPPORT	
36	018400832	3	アナホ"ルト4X8	BOLT 4X8	
37	028040242	3	ハ"ネサ"カ"ネ2-4	SPRING WASHER 2-4	
38	S24830001	1	リミットササエY	LIMIT SUPPORT (Y)	
39	S24831001	1	リミットササエカハ"ーY	LIMIT SUPPORT COVER (Y)	
40	018400832	2	アナホ"ルト4X8	BOLT 4X8	
41	028040242	2	ハ"ネサ"カ"ネ2-4	SPRING WASHER 2-4	
42	018501622	16	アナホ"ルト5X16	BOLT 5X16	
43	028050242	16	ハ"ネサ"カ"ネ2-5	SPRING WASHER 2-5	
44	014400522	2	アナクホ"ミ4X5	SET SCREW 4X5	
46	S24770001	1	センサーカハ"ー	SENSOR COVER	
47	S10243000	2	ナイロンクランプ°NK-3N	CORD HOLDER NK-3N	
48	149547000	2	コート"オサエ4N	CORD HOLDER (4N)	
49	S00480000	2	コート"ホルタ"5N	CORD HOLDER (5N)	
50	062400806	9	ナへ"コ4X8	SCREW M4X8	
51	025040233	9	ヒラサ"カ"ネチユウ4	PLAIN WASHER 4	
52	008400604	6	+トラスコ4X6	SCREW 4X6	
53	S11816000	3	クランプ°NK-2N	CLAMP NK-2N	

J. 送り案内関係 / Feed guide mechanism / Transportführung /
 Mécanisme du guide de l'entraînement / Mecanismo de la guía de alimentación

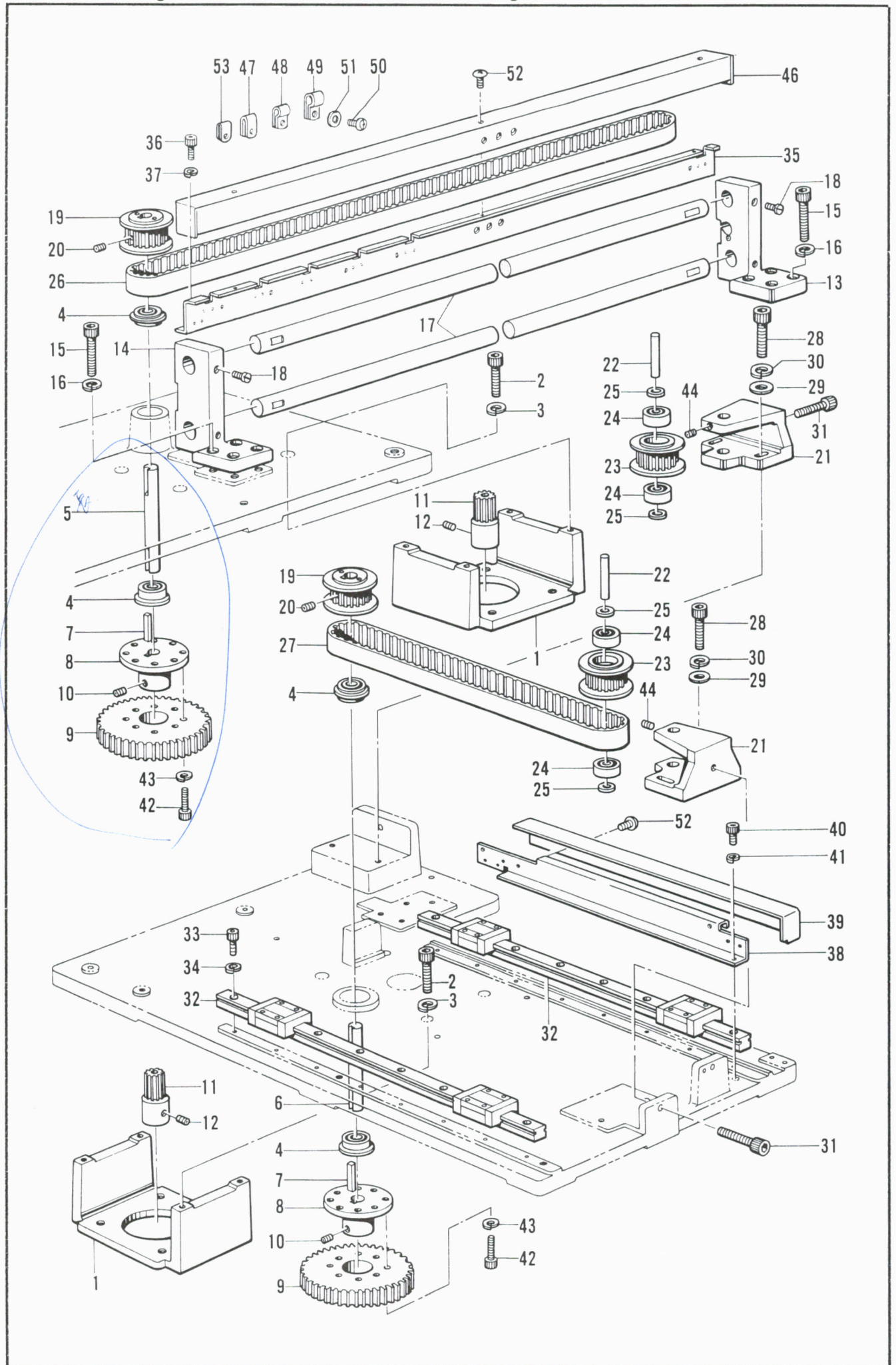

H. 駆動側・送り関係/Drive, feed mechanism/Transportvorrichtung/
 Mécanisme d'alimentation, entraînement/Mecanismo de alimentación, mando

REF.NO.	CODE	Q'TY	ヒンメイ	NAME OF PARTS	RMKS
61	028080242	2	ハ"ネサ"カ"ネ2-8	SPRING WASHER 2-8	
62	S12060001	1	イチキ"メヒ"ン	POSITIONING PIN	
63	014500522	1	ア"ナトメネシ"5クホ"ミ	SET SCREW 5	
64	S24765001	1	ミ"シ"ンウケ"ダ"イR	HEAD SUPPORT BASE (R)	
65	018082022	2	ア"ナホ"ルト8X20	BOLT 8X20	
66	028080242	2	ハ"ネサ"カ"ネ2-8	SPRING WASHER 2-8	
67	S12060001	1	イチキ"メヒ"ン	POSITIONING PIN	
68	014500522	1	ア"ナトメネシ"5クホ"ミ	SET SCREW 5	
69	152859001	1	ト"ウフ"サ"サエレハ"ーハ"ネ	SPRING	
70	152858001	1	ト"ウフ"サ"サエレハ"ー"ジ"ク	HEAD SUPPORT LEVER SHAFT	
71	S24766001	1	ト"ウフ"サ"サエレハ"ー	HEAD SUPPORT LEVER	
72	014400522	1	ア"ナクホ"ミ4X5	SET SCREW 4X5	
73	S12062009	1	ト"ウフ"ウケ	HEAD BASE	
74	018082022	2	ア"ナホ"ルト8X20	BOLT 8X20	
75	028080242	2	ハ"ネサ"カ"ネ2-8	SPRING WASHER 2-8	
76	062762012	4	ナ"ヘ"コ595-28X20	SCREW 595X20	
77	028060242	4	ハ"ネサ"カ"ネ2-6	SPRING WASHER 2-6	
78	S04587000	2	ス"ト"レ"ー"ツ"キ"テ	STRAIGHT JOINT	
79	S15545000	1	U"ナ"ツ"トM8P1	U-NUT M8P1	
80	S17724001	1	セ"ン"サ"ー"ト"リ"ツ"ケ"イ"タ"シ"タ	SENSOR SET PLATE LOWER	
81	018400832	2	ア"ナホ"ルト4X8	BOLT 4X8	
82	028040242	2	ハ"ネサ"カ"ネ2-4	SPRING WASHER 2-4	
83	S15551001	1	セ"ン"サ"ー"ト"リ"ツ"ケ"イ"タ"ウ"エ	SENSOR SET PLATE UPPER	
84	025040232	2	ヒ"ラ"サ"カ"ネ"チ"ユ"ウ4	PLAIN WASHER 4	
85	113431002	8	サ"カ"ネ	WASHER	

A1. 動力台関係 / Power table / Motorgestell /
 Mécanisme du plateau de la machine / Mecanismo de la mesa de la máquina

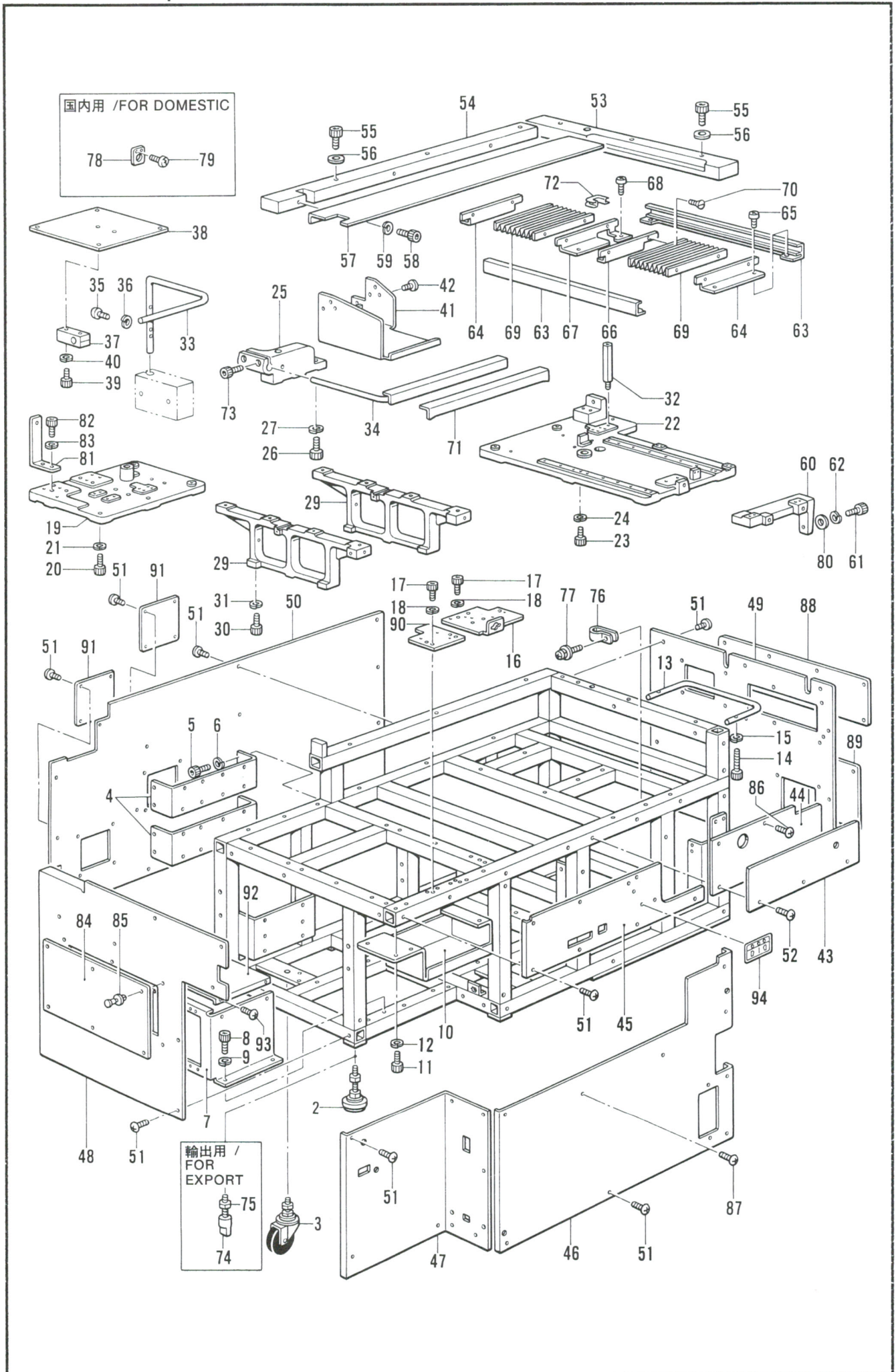

X. モーター関係/Motor mechanism/Motor/
Mécanisme du moteur/Mecanismo del motor

REF.NO.	CODE	Q'TY	ヒンメイ	NAME OF PARTS	RMKS
1	S24959009	1	DDモータブ"ラケット	DD-MOTOR BRACKET	
2	028060242	3	ハ"ネサ"カ"ネ2-6	SPRING WASHER 2-6	
3	018062522	3	アナホ"ルト6X25	BOLT 6X25	
4	S24960009	1	プ-リカハ-	PULLEY COVER	
5	062400812	2	ナヘ"コ4X8	SCREW 4X8	
6	028040242	2	ハ"ネサ"カ"ネ2-4	SPRING WASHER 2-4	
7	S11936101	1	センサトメカラー	SENSOR STOP COLLAR	
8	018401022	2	アナホ"ルト4X10	BOLT 4X10	
9	S11937001	1	センサト"ク"クミ	SENSOR DOG ASSEMBLY	
10	014400422	2	アナトメネシ"4X4クホ"ミ	SET SCREW 4X4	
11	S24963009	1	プ-リ	PULLEY	
12	014680622	2	アナトメネシ"4.37クホ"ミ	SET SCREW 4.37	
13	S24964000	1	カツプ"リング"クミ	COUPLING ASSEMBLY	
13-1	S24965000	2	カツプ"リング"A	COUPLING (A)	
13-2	S24966000	1	カツプ"リング"B	COUPLING (B)	
14	062401212	2	ナヘ"コ4X12	SCREW 4X12	
15	152914001	2	コロ	ROLLER	
16	018402032	2	アナホ"ルト4X20	BOLT 4X20	
17	100645003	2	サ"カ"ネ	WASHER	
18	028040242	2	ハ"ネサ"カ"ネ2-4	SPRING WASHER 2-4	

Y. 踏板関係/Foot switch pedal mechanism/Fußbetätigung/
Mécanisme de la pédale/Mecanismo del pedal

REF.NO.	CODE	Q'TY	ヒンメイ	NAME OF PARTS	RMKS
1	S12222009	1	フットスイッチイタLクミ	FOOT SWITCH PLATE (L) ASSEMBLY	
1-1	S06550001	1	フットスイッチ2タ"ンクミ	FOOT SWITCH 2-STAGE ASSEMBLY	
1-1-1	S06551101	1	2タ"ンスイッチクミ	2-STAGE SWITCH ASSEMBLY	
1-1-2	S06552000	1	1タ"ンスイッチ	1-STAGE SWITCH	
1-2	S01824000	2	スイッチウケ	SWITCH SUPPORT	
1-3	034311302	10	+ サラモクネシ"3.1X13	SCREW 3.1X13	
1-4	159150009	4	カマシ"クメクラセン	OIL CAP	

X. モーター関係/Motor mechanism/Motor/
 Mécanisme du moteur/Mecanismo del motor

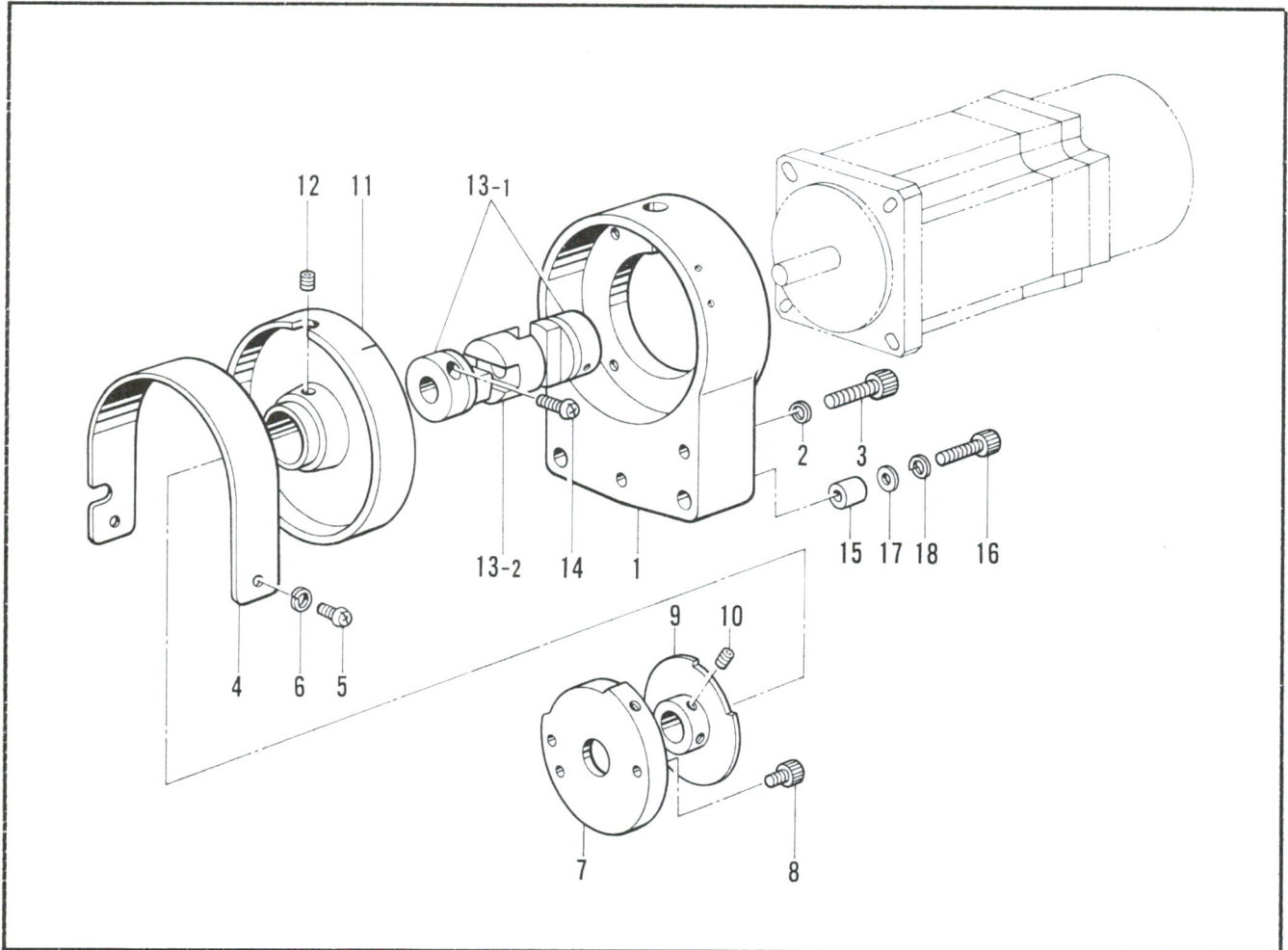

Y. 踏板関係/Foot switch pedal mechanism/Fußbetätigung/
 Mécanisme de la pédale/Mecanismo del pedal

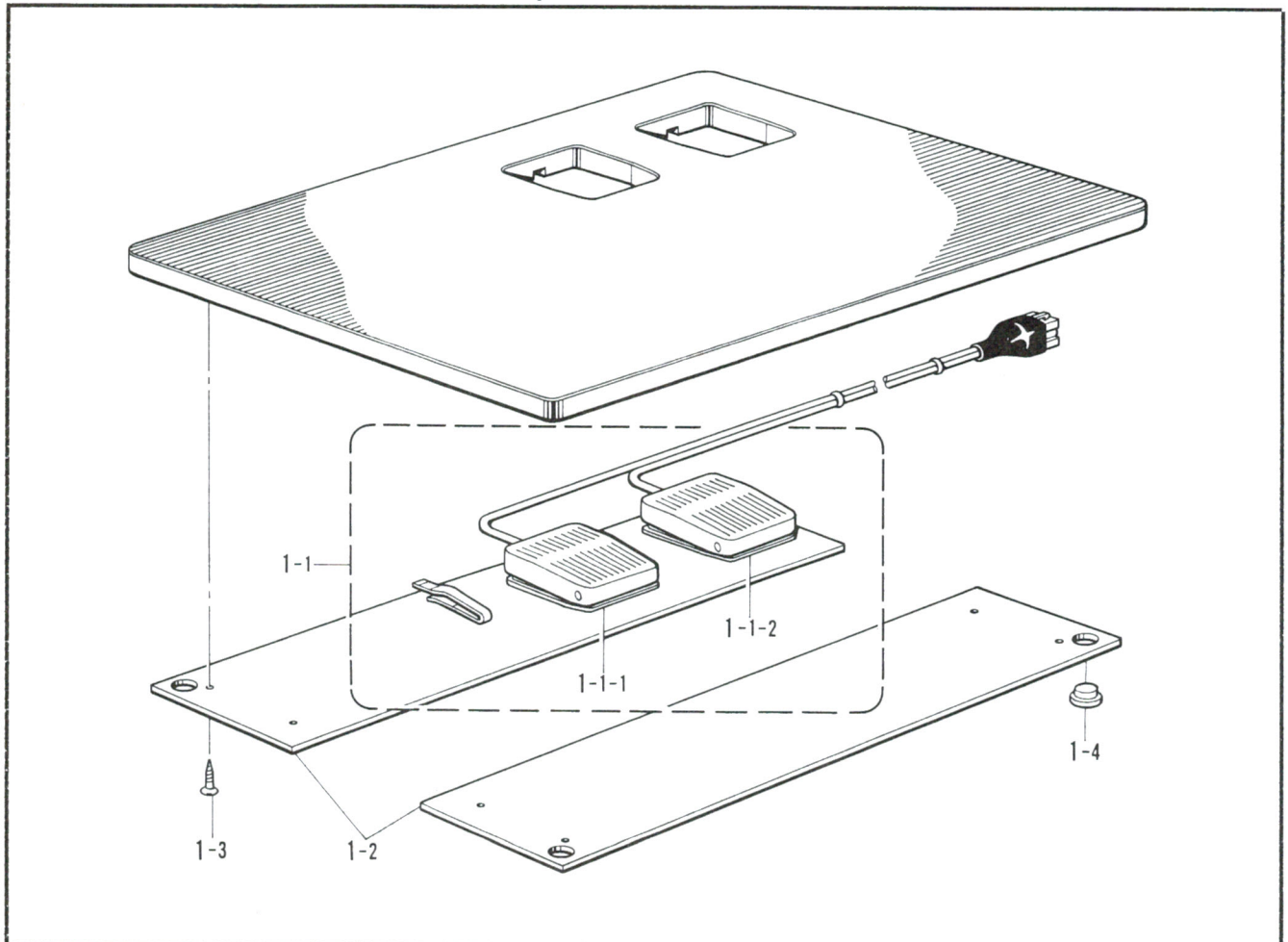

W. マーカー関係/Marker mechanism/Markierungsvorrichtung/
Mécánisme du marqueur/Mecanismo del marcador

REF.NO.	CODE	Q'TY	ヒンメイ	NAME OF PARTS	RMKS
1	S12216001	1	ト"タ"イスペ"ーサー	BASE SPACER	
2	018501622	2	アナホ"ルト5X16	BOLT 5X16	
3	028050242	2	ハ"ネサ"カ"ネ2-5	SPRING WASHER 2-5	
4	S12217001	1	ランプト"リツケ"タイ	LAMP SET STUD	
5	018502022	2	アナホ"ルト5X20	BOLT 5X20	
6	028050242	2	ハ"ネサ"カ"ネ2-5	SPRING WASHER 2-5	
7	S23399001	1	ランプト"タ"イササエL	LAMP BASE SUPPORT (L)	
8	S23400001	1	ハ"ネルササエ	PANEL SUPPORT	
9	S23401001	1	ブ"ローササエ	BLOW SUPPORT	
10	018501622	5	アナホ"ルト5X16	BOLT 5X16	
11	028050242	5	ハ"ネサ"カ"ネ2-5	SPRING WASHER 2-5	
12	018502022	1	アナホ"ルト5X20	BOLT 5X20	
13	018501622	2	アナホ"ルト5X16	BOLT 5X16	
14	028050242	2	ハ"ネサ"カ"ネ2-5	SPRING WASHER 2-5	
15	S17711101	1	ランプト"リツケ	LAMP SETTER	
17	S24958001	2	マーカート"リツケ"ミキ"	MARKER SETTER RIGHT	
18	S14488000	2	マーキング"ライト"クミ	MARKING LIGHT ASSEMBLY	
18-1	S08367000	2	ライト"マーカ	MARKING LIGHT	
18-2	S08017000	2	オスピン"5006TL	PIN	
19	018502022	3	アナホ"ルト5X20	BOLT 5X20	
20	018503022	2	アナホ"ルト5X30	BOLT 5X30	
21	018502522	2	アナホ"ルト5X25	BOLT 5X25	
22	028050242	2	ハ"ネサ"カ"ネ2-5	SPRING WASHER 2-5	
23	S20246001	2	ヒラサ"カ"ネタ"イ5	PLAIN WASHER 5	
24	028050242	3	ハ"ネサ"カ"ネ2-5	SPRING WASHER 2-5	
25	149547000	1	コート"オサエ"4N	CORD HOLDER (4N)	
26	525664000	2	コート"ホルタ"6N	CORD HOLDER (6N)	
27	052400806	2	ナヘ"コハ"ネヒラ4X8	WASHER SCREW 4X8	
28	062400806	3	ナヘ"コ4X8	SCREW M4X8	
29	025040233	3	ヒラサ"カ"ネチユウ4	PLAIN WASHER 4	
30	S08137000	1	ランプ"5W	LAMP 5W	
31	S04159000	5	ハ"ント"1M	BAND 1M	

W. マーカー関係/Marker mechanism/Markierungsvorrichtung/
 Mécanisme du marqueur/Mecanismo del marcador

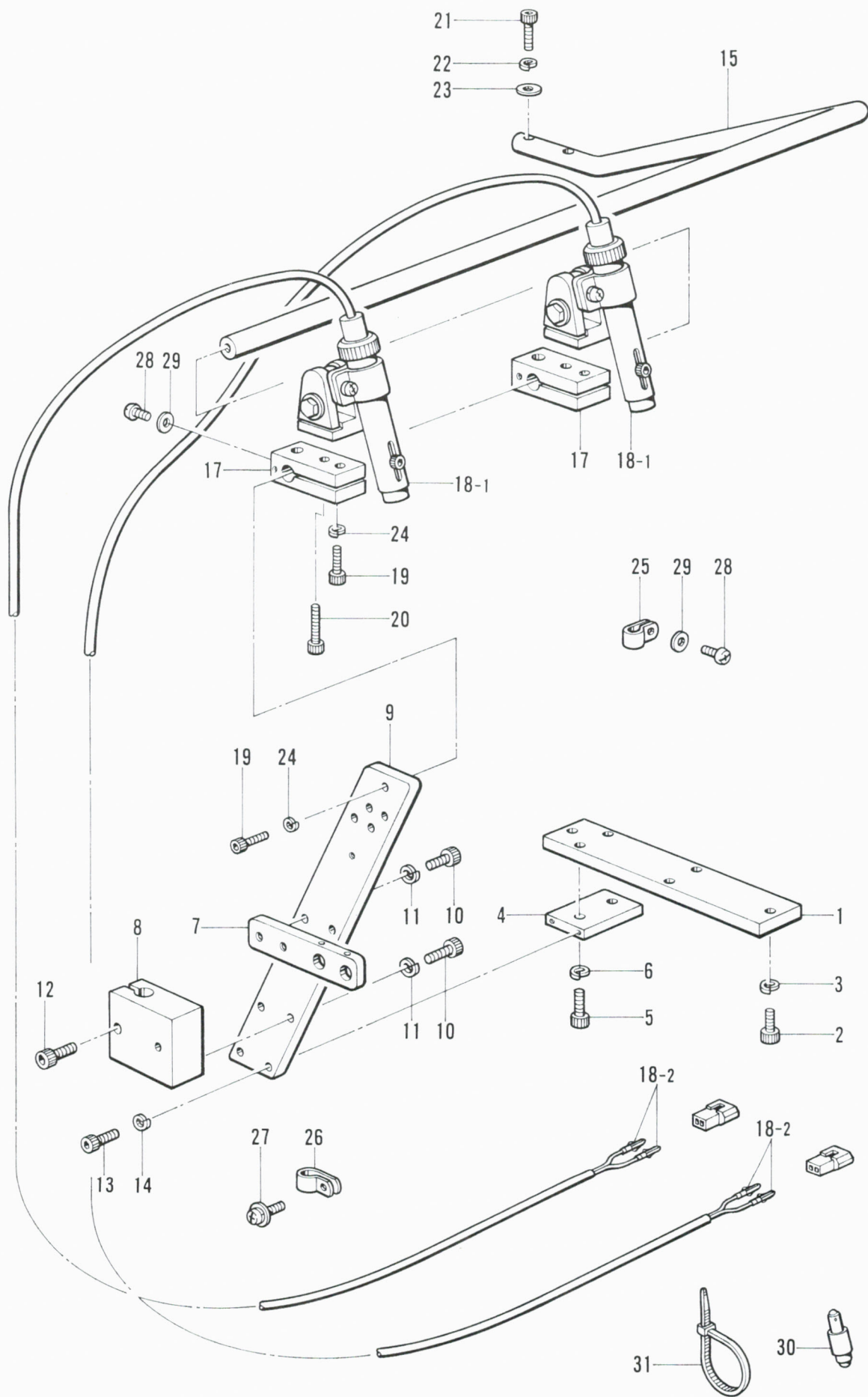

**U. ボトム関係/Bottom mechanism/Unterer Mechanismus/
Mécanisme inférieur/Mecanismo del fondo**

REF.NO.	CODE	Q'TY	ヒンメイ	NAME OF PARTS	RMKS
1	S24771001	1	ボトムプランジヤ	BOTTOM PLUNGER	
2	148537001	4	サラネジ"4.37	SCREW 4.37	
3	S24772001	1	ハリアナイタ	NEEDLE HOLE	
4	100360003	2	サラネジ"2.38	SCREW 2.38	

**V. プリント基板関係/Printed circuit board mechanism/Leiterplatten/
Circuits imprimés/Tableros de circuitos impresos**

REF.NO.	CODE	Q'TY	ヒンメイ	NAME OF PARTS	RMKS
1	S23871001	1	メインキハ"ンクミJ	MAIN CIRCUIT BOARD ASSEMBLY	
2	S21186101	1	オリキキハ"ンクミL	FOLDING MACHINE CIRCUIT BOARD ASSEMBLY	
3	S23325000	1	PROM760-1	PROM 760-1	
4	S23326000	1	PROM760-2	PROM 760-2	

U. ボトム関係 / Bottom mechanism / Unterer Mechanismus /
Mécánisme inférieur / Mecanismo del fondo

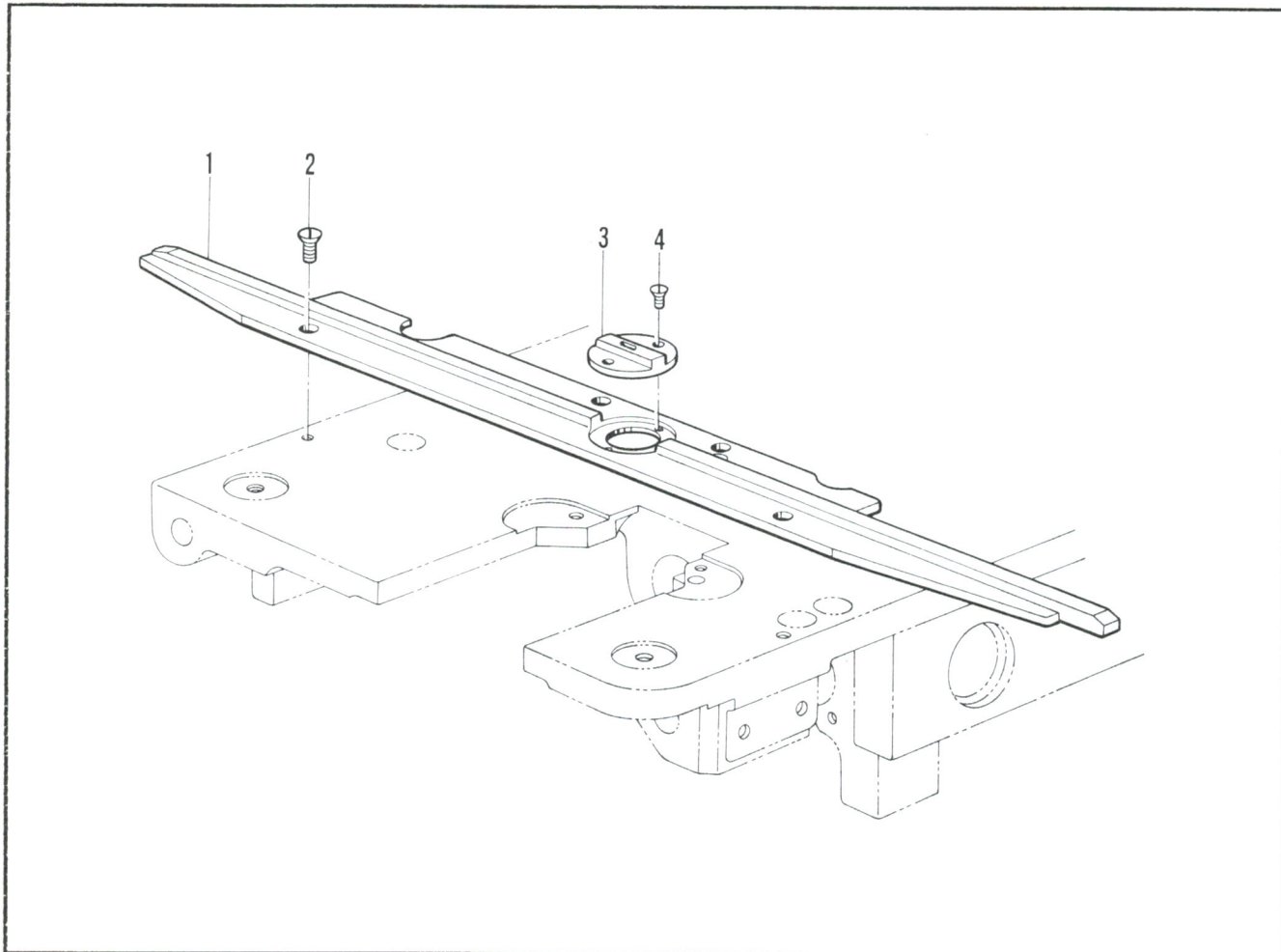

V. プリント基板関係 / Printed circuit board mechanism / Leiterplatten /
Circuits imprimés / Tableros de circuitos impresos

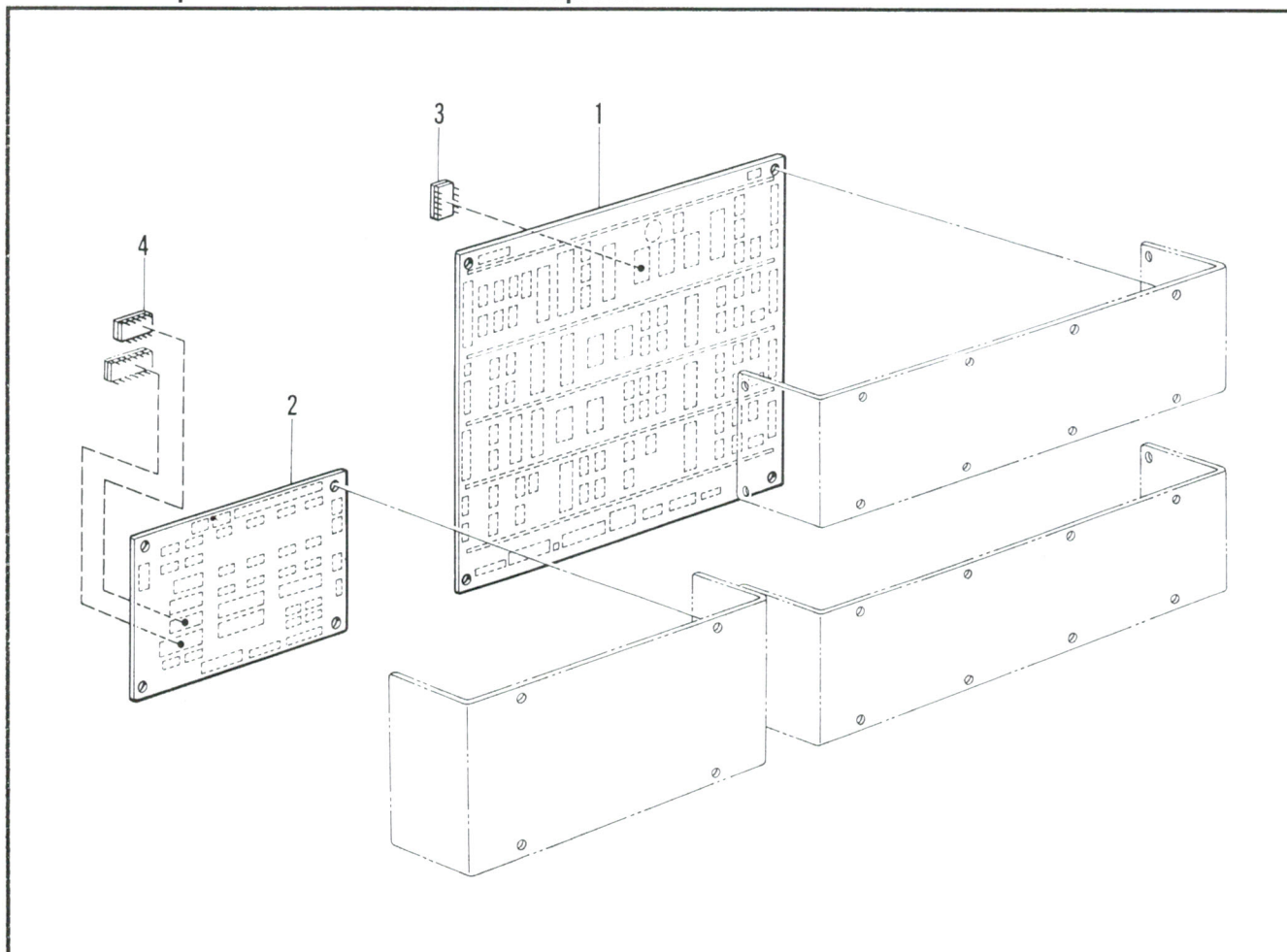

T. 電装品関係 / Power supply equipment mechanism / Stromversorgung /
 Mécanisme de l'équipement en alimentation électrique / Mecanismo del equipo de alimentación de corriente

REF.NO.	CODE	Q'TY	ヒンメイ	NAME OF PARTS	RMKS
107	S25868000	1	オサエセンサN	SEWING CLAMP SENSOR (N)	
108	S12214000	1	スパイラル640L	SPIRAL (640L)	
109	S19509000	1	オサエアシハーネスN	WORK CLAMP HARNESS (N)	
110	S19510000	1	ソレノイド"クト"ウハーネスN	SOLENOID DRIVING HARNESS (N)	
113	S21190000	1	ハリフリハ"ルブ"ハーネス	ZIGZAG VALVE HARNESS	
114	S21193000	1	ラハ"ルハ"ルブ"ハーネス	LABEL VALVE HARNESS	
115	S29470000	1	マシンセンサクミN	MACHINE SENSOR ASSEMBLY (N)	
115-1	S11830400	1	シリンダ"センサ1	CYLINDER SENSOR 1	
115-2	S29467000	1	アンプユニットN	AMP UNIT (N)	
116	062300612	2	ナヘ"コ3X6	SCREW 3X6	
117	028030242	2	ハ"ネサ"カ"ネ2-3	SPRING WASHER 2-3	
118	S20551000	1	マシンモータ330Wクミ	MACHINE MOTOR (330W) ASSEMBLY	
119	018502022	4	アナホ"ルト5X20	BOLT 5X20	
120	028050242	4	ハ"ネサ"カ"ネ2-5	SPRING WASHER 2-5	
121	025050132	4	ヒラサ"カ"ネシヨウ5	PLAIN WASHER 5	
122	S12463001	2	センサキハ"ンクミ1	SENSOR CIRCUIT BOARD ASSEMBLY-1	
122-1	S11828000	2	センサキハ"ンクミ	SENSOR CIRCUIT BOARD ASSEMBLY	
122-2	S12461001	2	センサフ"ラケット	SENSOR BRACKET	
122-3	062300612	4	ナヘ"コ3X6	SCREW 3X6	
122-4	028030242	4	ハ"ネサ"カ"ネ2-3	SPRING WASHER 2-3	
123	062300612	2	ナヘ"コ3X6	SCREW 3X6	
124	028030242	2	ハ"ネサ"カ"ネ2-3	SPRING WASHER 2-3	
125	025030132	2	ヒラサ"カ"ネシヨウ3	PLAIN WASHER 3	
126	149809000	2	タイラツプL	BEAD BAND (L)	
137	S21191000	1	ハリフリセンサ	ZIGZAG SENSOR	
141	S06143000	1	ハ"ンタイPLT4S	BAND PLT4S	
142	S27927000	1	サーキットプロテクタ2.5A	CIRCUIT PROTECTOR (2.5A)	
143	062300606	4	ナヘ"コ3X6	SCREW 3X6	
144	028030243	4	ハ"ネサ"カ"ネ2-3	SPRING WASHER 2-3	
145	S27933000	1	ブ"ローモーターハーネス1	BLOW MOTOR HARNESS 1	
146	S27934000	1	ブ"ローモーターハーネス2	BLOW MOTOR HARNESS 2	
147	S27929000	1	スタツカー-SWクミ	STACKER SWITCH ASSEMBLY	
148	S27931000	2	LEDハーネス	LED HARNESS	
149	S27935000	1	スタツカーハーネス	STACKER HARNESS	
<コクナイヨウ /FOR DOMESTIC>					
45	S11700000	1	フツトSWハーネス	-----	
<ユシュツヨウ /FOR EXPORT>					
101	S24954001	1	-----	HAND SWITCH ASSEMBLY (J)	
101-1	S12565009	2	-----	HAND SWITCH ASSEMBLY (A)	
101-2	S12465000	1	-----	FOOT SWITCH HARNESS 2	
101-3	S04159000	5	-----	BAND 1M	
101-4	S24955001	1	-----	SWITCH SET BAR	
101-5	S24956001	2	-----	SET BAR SUPPORT	
101-6	018502022	4	-----	BOLT 5X20	
101-7	S24957001	2	-----	SWITCH SET PLATE	
101-8	062400806	4	-----	SCREW M4X8	
101-9	003400804	4	-----	SCREW 4X8	
101-10	028040243	4	-----	SPRING WASHER 2-4	

T. 電装品関係 / Power supply equipment mechanism / Stromversorgung /
 Mécanisme de l'équipement en alimentation électrique / Mecanismo del equipo de alimentación de corriente

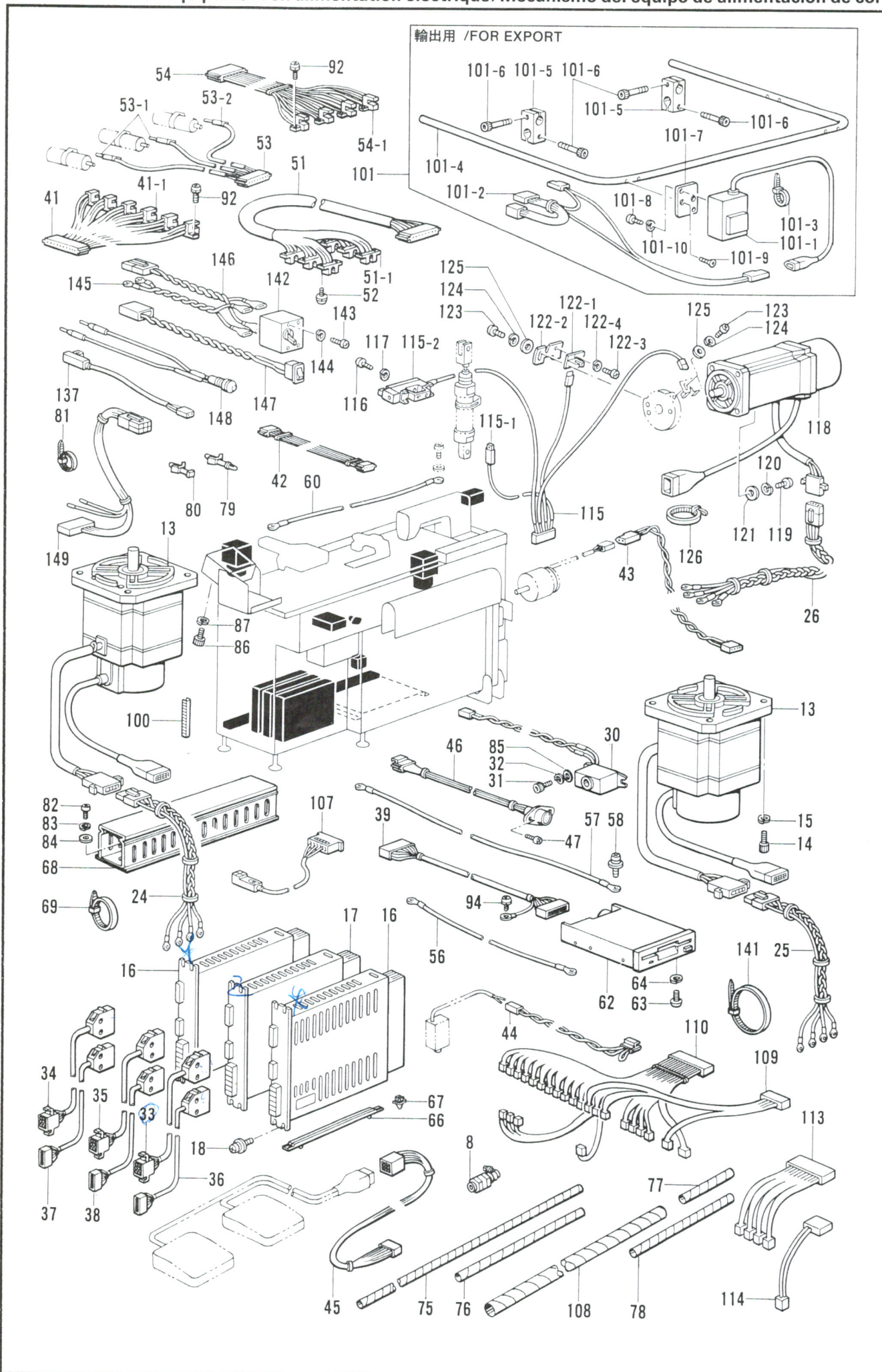

T. 電装品関係 / Power supply equipment mechanism / Stromversorgung /
 Mécanisme de l'équipement en alimentation électrique / Mecanismo del equipo de alimentación de corriente

REF.NO.	CODE	Q'TY	ヒンメイ	NAME OF PARTS	RMKS
8	152510000	1	コード"フ"ツシユ	CORD BUSH	
13	S20045000	2	クト"ウモータXYクミ	DRIVING MOTOR (XY) ASSEMBLY	
14	018082022	8	アナホ"ルト8X20	BOLT 8X20	
15	028080242	8	ハ"ネサ"カ"ネ2-8	SPRING WASHER 2-8	
16	S20047000	2	サーボ"アンプ"-XY	SERVO AMPE (XY)	
17	S20552000	1	サーボ"アンプ"-Z330W	SERVO AMPE Z330W	
18	602394001	12	+ナヘ"ネシ"4X16SWツキ	WASHER SCREW 4X16	
24	S25209000	1	モータ"パワー"ハーネスX	MOTOR POWER HARNESS (X)	
25	S25210000	1	モータ"パワー"ハーネスY	MOTOR POWER HARNESS (Y)	
26	S25575000	1	モータ"パワー"ハーネスZ	MOTOR POWER HARNESS (Z)	
30	S11693000	1	ブ"サ"ークミ	BUZZER ASSEMBLY	
31	018400822	2	アナホ"ルト4X8	BOLT 4X8	
32	028040242	2	ハ"ネサ"カ"ネ2-4	SPRING WASHER 2-4	
33	S25579100	1	エンコーダ"ハーネスX	ENCODER HARNESS (X)	
34	S25580100	1	エンコーダ"ハーネスY	ENCODER HARNESS (Y)	
35	S25581100	1	エンコーダ"ハーネスZ	ENCODER HARNESS (Z)	
36	S25576000	1	サーボ"ハーネスX	SERVO HARNESS (X)	
37	S25577000	1	サーボ"ハーネスY	SERVO HARNESS (Y)	
38	S25578000	1	サーボ"ハーネスZ	SERVO HARNESS (Z)	
39	S11694000	1	FDDハーネス	FDD HARNESS	
41	S11696100	1	フォトセンサクミ	PHOTO SENSOR ASSEMBLY	
41-1	S08119000	6	ホトセンサ-EE-SV3	PHOTO SENSOR EE-SV3	
42	S11697000	1	オリキハーネス	FOLDING MACHINE HARNESS	
43	S11698000	1	イトキリハーネス	THREAD TRIMMER HARNESS	
44	S11703000	1	エアSWハーネス	AIR SWITCH HARNESS	
46	S11701000	1	プログ"ラマ"ハーネス	PROGRAMMER HARNESS	
47	062300505	2	ナヘ"コ3X5	SCREW 3X5	
51	S11715200	1	ジ"グ"ハ"ター"ンクミ	JIG PATTERN ASSEMBLY	
51-1	S05035000	6	フォトマイクロセンサ	PHOTO MICRO SENSOR	
52	215083001	12	+ナヘ"セット3X6D	WASHER SCREW 3X6D	
53	S11712000	1	シリンダ"センサクミ	CYLINDER SENSOR ASSEMBLY	
53-1	S12458000	2	シリンダ"センサ2	CYLINDER SENSOR-2	
53-2	S12459000	1	シリンダ"センサ3	CYLINDER SENSOR-3	
54	S11711000	1	クランプ"イン"センサクミ	CLAMP-IN SENSOR ASSEMBLY	
54-1	S08119000	4	ホトセンサ-EE-SV3	PHOTO SENSOR EE-SV3	
56	S11730000	1	アースセン700	EARTH WIRE (700)	
57	S11731000	1	アースセン1300	EARTH WIRE (1300)	
58	052400806	1	ナヘ"コハ"ネヒラ4X8	WASHER SCREW 4X8	
60	S11732000	1	アースセン1700S	EARTH WIRE (1700S)	
62	S16661001	1	3.5フロッピ"ード"ドライブ"	3.5 INCH FLOPPY DRIVE	
63	062300805	4	ナヘ"コ3X8	SCREW 3X8	
64	028030243	4	ハ"ネサ"カ"ネ2-3	SPRING WASHER 2-3	
66	S11840000	6	カ"イト"レール	GUIDE RAIL	
67	S11841000	6	キハ"ンコ"テイ"ダ"イ	CIRCUIT BOARD FIXID STUD	
68	S11842000	1	ケー"ブル"タ"クト	CABLE DUCT	
69	149809000	3	タイラツプ"L	BEAD BAND (L)	
75	S12215000	2	スハ°イラル640S	SPIRAL (640S)	
76	S12212000	1	スハ°イラル290S	SPIRAL (290S)	
77	S11763000	2	スハ°イラル100S	SPIRAL (100S)	
78	S11762000	1	スハ°イラル200S	SPIRAL (200S)	
79	S02915100	8	キハ"ンサ"ホ"ート	CIRCUIT BOARD SUPPORT	
80	S11839000	14	キハ"ンス"ホ"ー"サ	CIRCUIT BOARD SPACER	
81	S04159000	10	ハ"ント"1M	BAND 1M	
82	062401006	2	ナヘ"コ4X10	SCREW 4X10	
83	028040243	2	ハ"ネサ"カ"ネ2-4	SPRING WASHER 2-4	
84	025040233	2	ヒラサ"カ"ネチユウ4	PLAIN WASHER 4	
85	025040232	2	ヒラサ"カ"ネチユウ4	PLAIN WASHER 4	
86	018400832	4	アナホ"ルト4X8	BOLT 4X8	
87	028040242	4	ハ"ネサ"カ"ネ2-4	SPRING WASHER 2-4	
92	215083001	20	+ナヘ"セット3X6D	WASHER SCREW 3X6D	
94	215083001	1	+ナヘ"セット3X6D	WASHER SCREW 3X6D	
100	S12466000	1	ジ"サ"イ"フ"ツシユB	FREE BUSH (B)	

T. 電装品関係/Power supply equipment mechanism/ Stromversorgung/
 Mécanisme de l'équipement en alimentation électrique/Mecanismo del equipo de alimentación de corriente

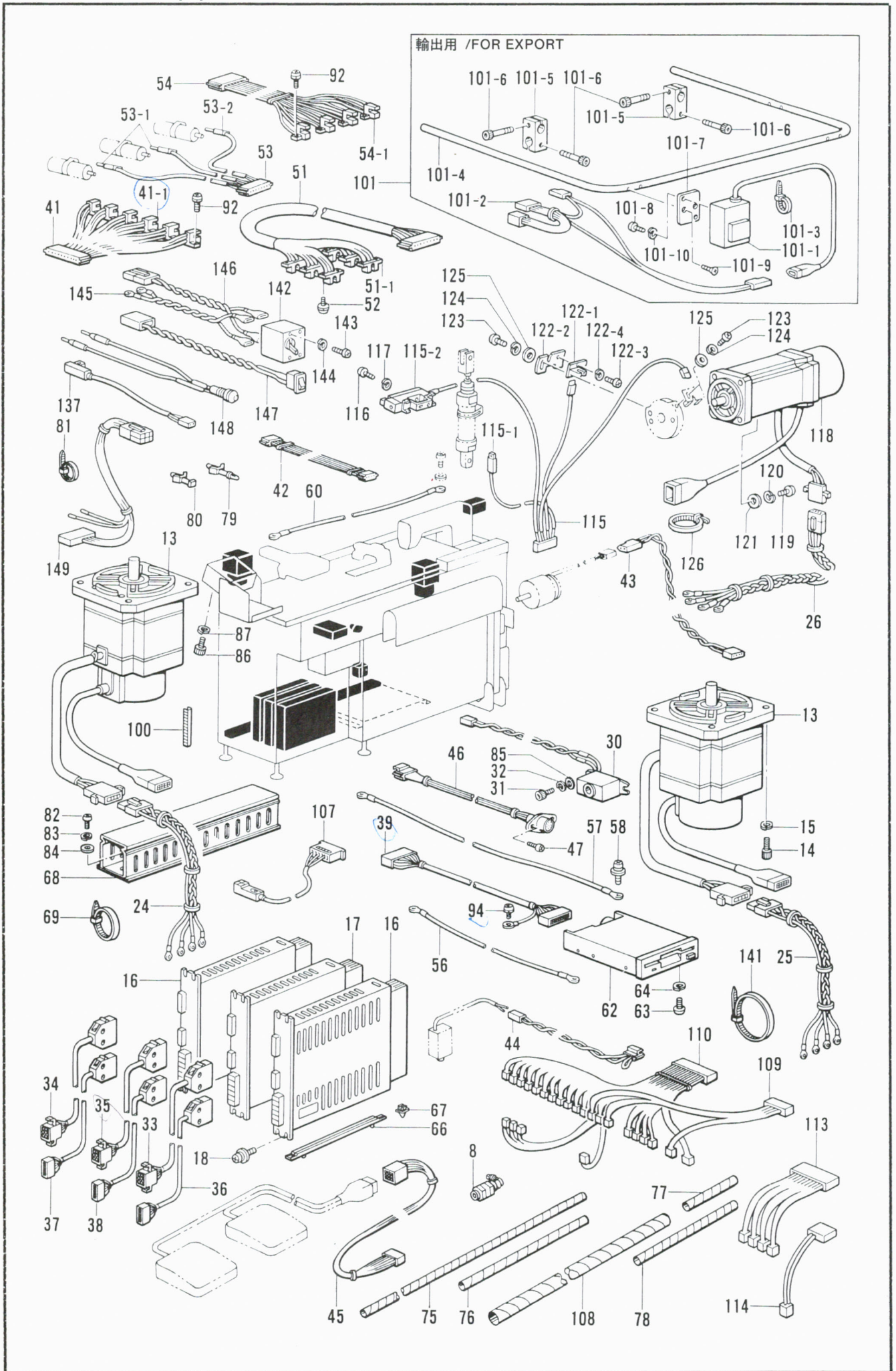

T. 電装品関係 / Power supply equipment mechanism / Stromversorgung /
 Mécanisme de l'équipement en alimentation électrique / Mecanismo del equipo de alimentación de corriente

REF.NO.	CODE	Q'TY	ヒンメイ	NAME OF PARTS	RMKS
73	150357001	6	コード"クランプ"13-L	CORD CLAMP (13-L)	
74	S11817000	4	クランプ"NK-18N	CLAMP NK-18N	
88	062300506	1	ナヘ"コ3X5	SCREW 3X5	
89	028030243	1	ハ"ネサ"カ"ネ2-3	SPRING WASHER 2-3	
90	025030133	1	ヒラサ"カ"ネシヨウ3	PLAIN WASHER 3	
91	025030233	1	ヒラサ"カ"ネチユウ3	PLAIN WASHER 3	
95	552908000	2	コード"ホルタ"14N	CORD HOLDER (14N)	
96	062400806	2	ナヘ"コ4X8	SCREW M4X8	
97	025040233	2	ヒラサ"カ"ネチユウ4	PLAIN WASHER 4	
98	149547000	1	コード"オサエ4N	CORD HOLDER (4N)	
111	S09142000	1	コード"クランプ"20-L	CORD CLAMP (20-L)	
127	149547000	2	コード"オサエ 4N	CORD HOLDER (4N)	
128	525664000	2	コード"ホルタ"6N	CORD HOLDER (6N)	
129	525567000	2	コード"ホルタ"8N	CORD HOLDER (8N)	
131	554482000	2	コード"ホルタ"12N	CORD HOLDER (12N)	
132	S00470000	1	コード"ホルタ"16N	CORD HOLDER (16N)	
133	S11817000	1	クランプ"NK-18N	CLAMP NK-18N	
134	062401006	8	ナヘ"コ4X10	SCREW 4X10	
135	062401412	2	ナヘ"コ4X14	SCREW 4X14	
136	025040233	10	ヒラサ"カ"ネチユウ4	PLAIN WASHER 4	
138	S23328000	1	テモトライトハーネス	HAND LIGHT HARNESS	
139	S23329000	1	マーカハーネスN	MARKER HARNESS (N)	
140	S23869200	1	アースインダ"クタ2S	EARTH INDUCTOR (2S)	
150	S11728000	1	アースインダ"クタ1	EARTH INDUCTOR (1)	
151	S11816000	2	クランプ"NK-2N	CLAMP NK-2N	
152	062400806	2	ナヘ"コ4X8	SCREW 4X8	
153	025040233	2	ヒラサ"カ"ネチユウ4	PLAIN WASHER 4	
<コクナイヨウ /FOR DOMESTIC>					
6-1	S10287000	1	ブレーカ10A	-----	
<ユシュツヨウ /FOR EXPORT>					
6-2	S08106000	1	-----	BREAKER (5A)	
102	S25584000	1	-----	TERMINAL HARNESS	
102-1	S11709000	1	-----	FUSE HOLDER	
103	151827000	1	-----	FUSE 0.5A	
104	S11708000	1	-----	TERMINAL BLOCK 2P	
105	018401222	2	-----	BOLT 4X12	
106	028040242	2	-----	SPRING WASHER 2-4	

T. 電装品関係/Power supply equipment mechanism/Stromversorgung/
 Mécanisme de l'équipement en alimentation électrique/Mecanismo del equipo de alimentación de corriente

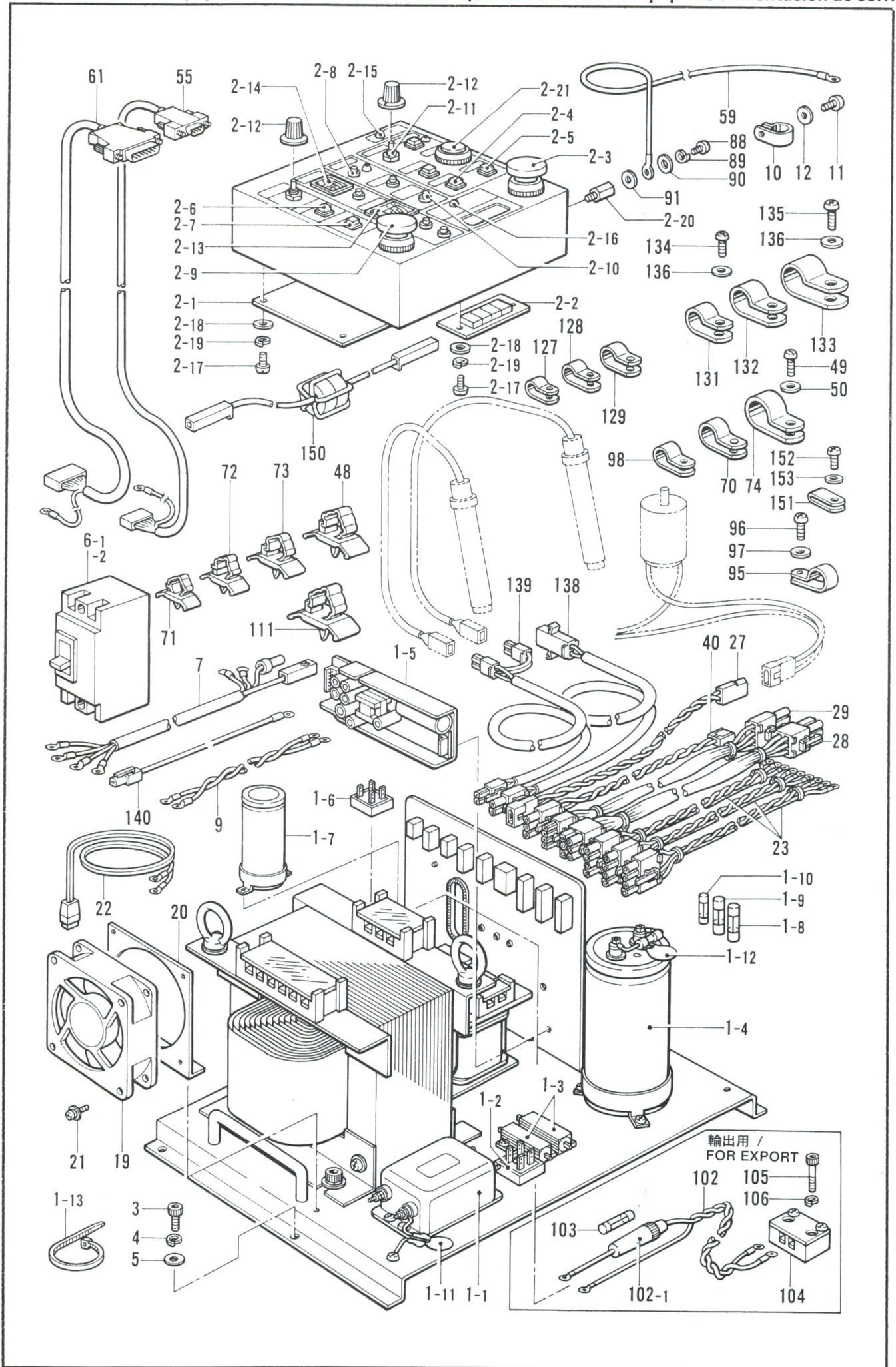

T. 電装品関係/Power supply equipment mechanism/Stromversorgung/
 Mécanisme de l'équipement en alimentation électrique/Mecanismo del equipo de alimentación de corriente

REF.NO.	CODE	Q'TY	ヒンメイ	NAME OF PARTS	RMKS
1	S20019001	1	デ"ンゲ"ンソウチクミ	POWER SUPPLY EQUIPMENT ASSEMBLY	
1-1	S11811000	1	ノイズ"フィルタA	NOISE FILTER (A)	
1-2	S20049000	1	SIBRS25VB60	SIBRS25VB60	
1-3	S20053000	2	メタルクラツト"テイコウ	METAL	
1-4	S20054000	1	デ"ンC400B332	ELECTRON 400B332	
1-5	S17029000	1	AVR	AVR	
1-6	S10315000	1	SIBRS15VB10	SIBRS15VB10	
1-7	S16558000	1	デ"ンC63B472	ELECTRON C63B472	
1-8	S04173000	1	ヒユース"20A	FUSE (20A)	
1-9	S20038000	1	ヒユース"3A	FUSE (3A)	
1-10	152565000	1	ヒユース"B	FUSE (B)	
1-11	S20051000	1	ノイズ"Cクミ	NOISE (C) ASSEMBLY	
1-12	S20029000	1	ブ"リ"ダ"テイコウクミ	BULLIDER	
1-13	S04557000	5	ハ"ンタイPLTIM	BAND PLTIM	
2	S21194009	1	760ソウサB0Xクミ	OPERATION BOX ASSEMBLY	
2-1	S11826000	1	ヒヨウシ"キハ"ンクミ	INDICATE CIRCUIT BOARD ASSEMBLY	
2-2	S11827000	1	LEDキハ"ンクミ	LIGHT EMITTING DIODE ASSEMBLY	
2-3	S11756100	1	スイッチ1M	SWITCH 1M <i>red</i>	
2-4	S11755000	1	スイッチ2M	SWITCH 2M	
2-5	S11754000	2	スイッチ3M	SWITCH 3M	
2-6	S11753000	2	スイッチ4M	SWITCH 4M	
2-7	S11752000	1	スイッチ5A	SWITCH 5A	
2-8	S11749000	5	スイッチ6M	SWITCH 6M	
2-9	S11750000	1	スイッチ7M	SWITCH 7M	
2-10	S11751000	1	スイッチ8M	SWITCH 8M	
2-11	S11748000	2	ロータリスイッチ	ROTARY SWITCH	
2-12	157875000	2	ロータリスイッチツツマミ	ROTARY SWITCH KNOB	
2-13	S11757000	1	デ"シ"SW3	DIGITAL SWITCH (3)	
2-14	S04993000	1	デ"シ"タルスイッチB	DIGITAL SWITCH (B)	
2-15	152430000	3	LED-B	LIGHT EMITTING DIODE (B)	
2-16	152429000	1	LED-A	LIGHT EMITTING DIODE (A)	
2-17	002300803	6	+ナヘ"ネシ"3X8	SCREW 3X8	
2-18	025030133	6	ヒラサ"カ"ネシヨウ3	PLAIN WASHER 3	
2-19	028030243	6	ハ"ネサ"カ"ネ2-3	SPRING WASHER 2-3	
2-20	S11761000	1	アースタンシ	EARTH TERMINAL	
2-21	S11706000	1	スイッチ9M	SWITCH 9M	
3	018400822	4	アナホ"ルト4X8	BOLT 4X8	
4	028040242	4	ハ"ネサ"カ"ネ2-4	SPRING WASHER 2-4	
5	025040232	4	ヒラサ"カ"ネチユウ4	PLAIN WASHER 4	
7	S23868000	1	デ"ンゲ"ンハーネスA	POWER SUPPLY HARNESS (A)	
9	S25585000	1	デ"ンゲ"ンハーネスB	POWER SUPPLY HARNESS (B)	
10	554482000	1	コート"ホルダ"12N	CORD HOLDER (12N)	
11	062400806	1	ナヘ"コ4X8	SCREW M4X8	
12	025040233	1	ヒラサ"カ"ネチユウ4	PLAIN WASHER 4	
19	S10335001	1	クーリング"ファン	COOLING FAN	
20	S11803001	1	FANトリツケイタ	FAN FIXING PLATE	
21	S21083001	3	+ナヘ"コハ"ネヒラ4X10	WASHER SCREW 4X10	
22	S25208000	1	ファンコート"クミ	FAN CORD ASSEMBLY	
23	S25582000	3	サーボ"デ"ンゲ"ンハーネス	SERVO POWER SUPPLY HARNESS	
27	S11702000	1	イトマキハーネス	BOBBIN WINDER HARNESS	
28	S25206000	1	メインハ"ワ"ハーネス	MIN POWER HARNESS	
29	S25207000	1	オリキハ"ワ"ハーネス	FOLDING POWER HARNESS	
40	S25583000	1	FDDデ"ンゲ"ンハーネス	FDD POWER SUPPLY HARNESS	
48	S09141000	10	コート"クランプ"16-L	CORD CLAMP (16-L)	
49	062400806	10	ナヘ"コ4X8	SCREW M4X8	
50	025040233	10	ヒラサ"カ"ネチユウ4	PLAIN WASHER 4	
55	S11716000	1	オリキソウサホ"ツクスハーネス	FOLDING MACHINE OPERATION BOX HARNESS	
59	S25205000	1	アースセン2000S	EARTH WIRE (2000S)	
61	S11717000	1	ソウサBOXハーネス	OPERATION BOX HARNESS	
70	S25907000	2	コート"ホルダ"9N	CORD HOLDER (9N)	
71	S11848000	5	コート"クランプ"7-L	CORD CLAMP (7-L)	
72	150349001	2	コート"クランプ"10-L	CORD CLAMP (10-L)	

T. 電装品関係 / Power supply equipment mechanism / Stromversorgung /
 Mécanisme de l'équipement en alimentation électrique / Mecanismo del equipo de alimentación de corriente

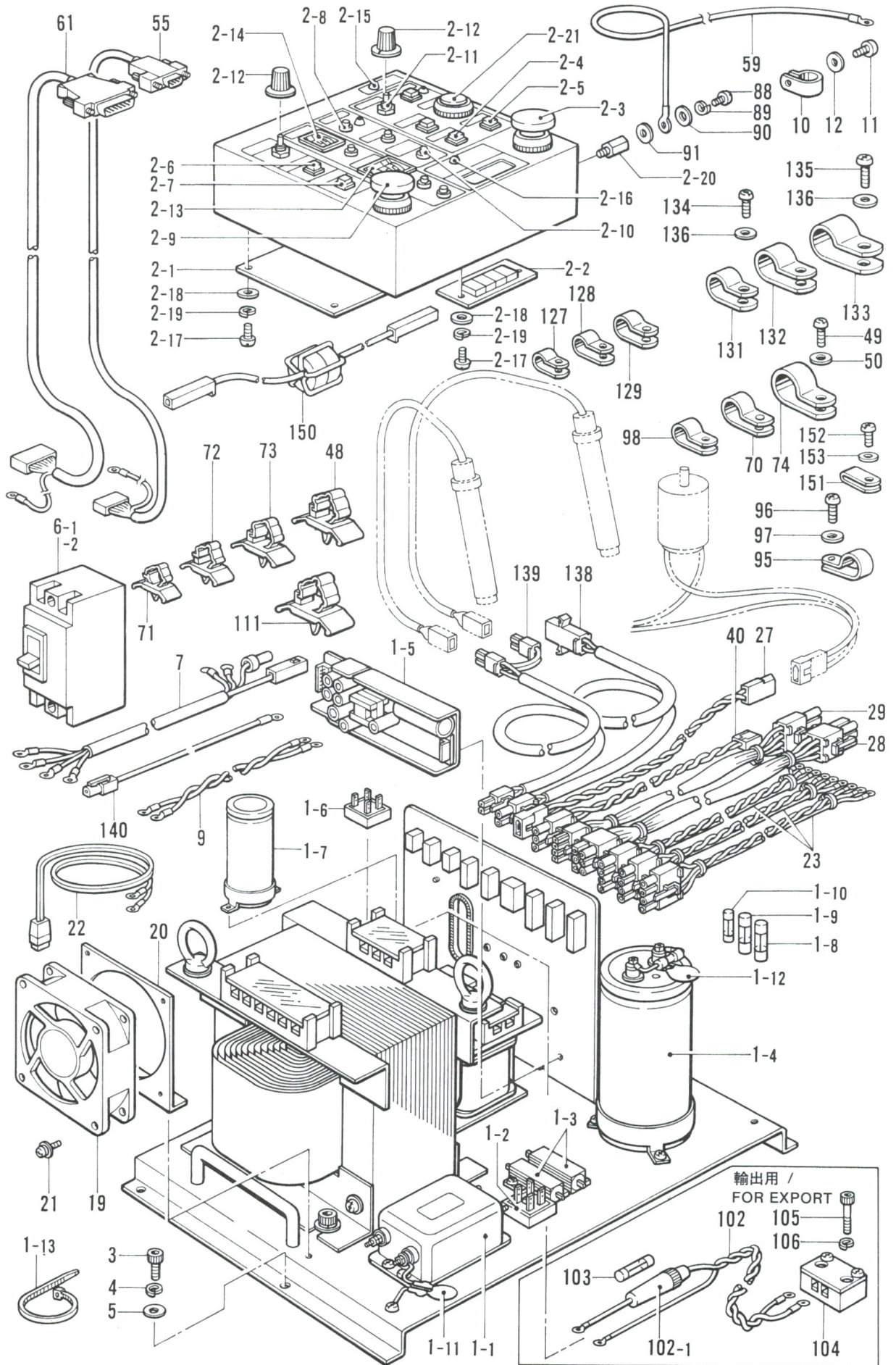

S. 空圧関係 / Air pressure mechanism / Luftdruck /
 Mécanisme de la pression d'air / Mecanismo de la presión de aire

REF.NO.	CODE	Q'TY	ヒンメイ	NAME OF PARTS	RMKS
79	S24944001	1	ハ"キユームソウチクミ	VACUUM EQUIPMENT ASSEMBLY	
79-1	S24945001	1	ハ"キユームシタ	VACUUM LOWER	
79-2	004401414	4	+ サラネジ"4X14	SCREW 4X14	
79-3	S24946000	1	シリンタ"16X15クミ	CYLINDER 16X15 ASSEMBLY	
79-3-1	S24947000	1	シリンタ"16X15	CYLINDER 16X15	
79-3-2	S04905000	2	ハーフユニオン	HALF UNION	
79-4	S24948001	1	スプ"ール	SPRUE	
79-5	S24949000	4	CQ2ホル"トM3X45	CQ2 BOLT	
79-6	028030243	4	ハ"ネサ"カ"ネ2-3	SPRING WASHER 2-3	
79-7	S25057001	1	フィルタ"ホ"ツクス	FILTER BOX	
79-8	S25056001	1	フィルタ"ササエ	FILTER SUPPORT	
79-9	S25058000	1	フィルタ"ネット	FILTER NET	
79-10	004400702	2	+ サラネジ"4X7	SCREW 4X7	
79-11	018402022	2	アナホ"ルト4X20	BOLT 4X20	
79-12	028040242	2	ハ"ネサ"カ"ネ2-4	SPRING WASHER 2-4	
79-13	S24950001	1	ホ"スクミ1300	HOSE ASSEMBLY (L=1300)	
79-13-1	S24951000	1	ホ"ス1270	HOSE (L=1270)	
79-13-2	150353001	1	カフス	CUFFS	
79-14	S24952000	3	ホ"スバンド"	HOSE BAND	
79-15	154778000	2	カツフ"リンク"	COUPLING	
79-16	143361000	1	サイレンサ"ー	SILENCER	
79-17	S27926000	1	ブ"ローモ"ータ106Pクミ	BLOW MOTOR 106P ASSEMBLY	
79-18	018082522	2	アナホ"ルト8X25	BOLT 8X25	
79-19	028080242	2	ハ"ネサ"カ"ネ2-8	SPRING WASHER 2-8	
79-20	S12191000	2	エ"ア"ホ"ス4X2.5-15	AIR TUBE 4X2.5-15 (L=770)	
<スタツカナシ.コクナイヨウ>					
6	*	1	ハ"ルフ"6クミ	-----	
6-1	S12163000	1	マニホ"ルト"6	-----	
6-2	S12161000	4	ハ"ルフ"VZ3143	-----	
6-3	S12160000	2	ハ"ルフ"VZ3143-N	-----	
6-4	S04897000	2	メクラセ"ン	-----	
6-5	140682001	2	サイレンサ"ン	-----	
6-6	S01542000	1	エルホ"ユニオン61	-----	
6-7	153274001	1	1/8ト"メセ"ン	-----	
<ユシュツヨウ /FOR EXPORT>					
78	S12495001	1	-----	TANK UNIT	
78-1	S11953000	1	-----	AIR TANK ASSEMBLY	
78-1-1	S11952000	1	-----	AIR TANK	
78-1-2	149438000	1	-----	SPEED CONTROLLER (B)	
78-1-3	S01522000	1	-----	HALF UNION	
78-2	018081622	2	-----	BOLT 8X16	
78-3	028080242	2	-----	SPRING WASHER 2-8	
78-4	025080232	2	-----	PLAIN WASHER 8	
78-5	S11956000	1	-----	AIR TUBE 10X75 (L=1700)	
78-6	S11957000	1	-----	T-JOINT 010	
78-7	S11958000	2	-----	REDUCER 010-06	
78-8	S12206000	1	-----	AIR TUBE 6X4-1 (L=50)	
78-9	021080302	2	-----	NUT 8	
78-10	S12207000	1	-----	AIR TUBE 6X4-2 (L=170)	
109	S25100000	1	-----	BALL VALVE ASSEMBLY	

S. 空圧関係 / Air pressure mechanism / Luftdruck /
 Mécanisme de la pression d'air / Mecanismo de la presión de aire

スタッカーナシ, 国内用

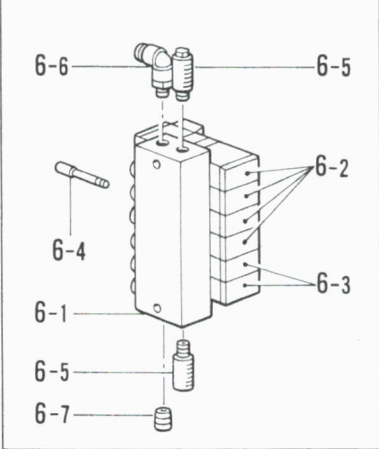

輸出用 / FOR EXPORT

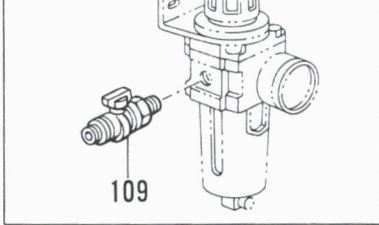

輸出用 / FOR EXPORT

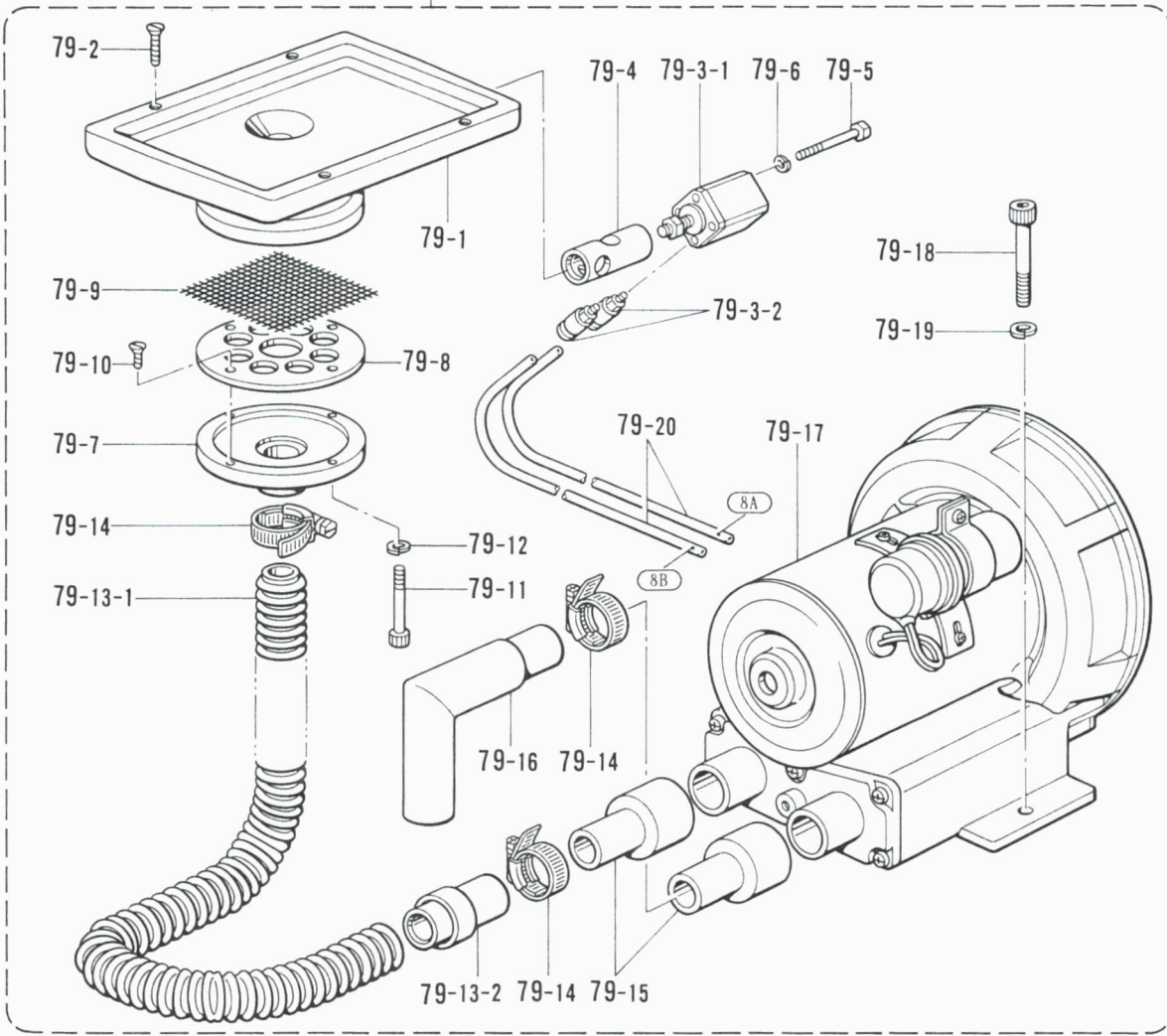
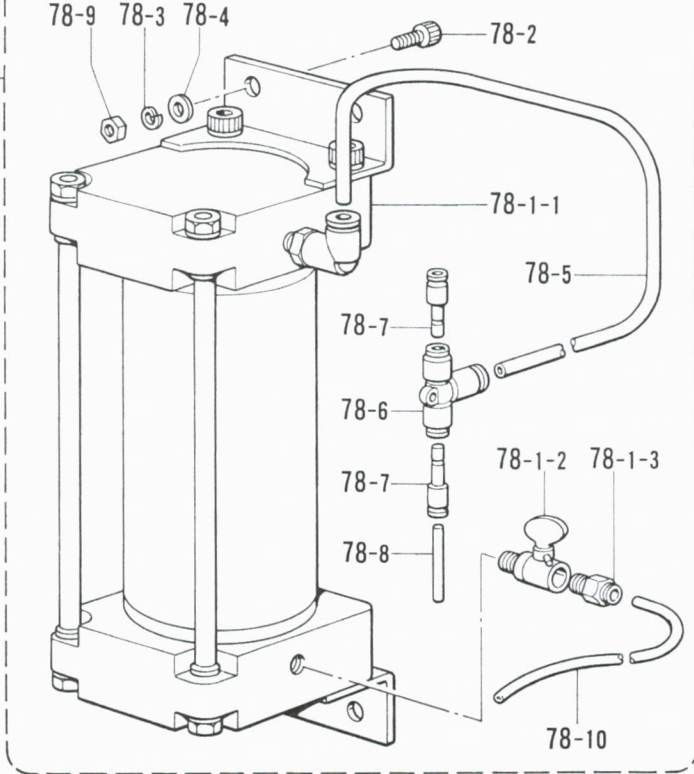

S. 空圧関係 / Air pressure mechanism / Luftdruck /
 Mécanisme de la pression d'air / Mecanismo de la presión de aire

REF.NO.	CODE	Q'TY	ヒンメイ	NAME OF PARTS	RMKS
114	S24895001	1	センサーブローサエ	SENSOR BLOW SUPPORT	
115	S14328000	1	シホリハツ	THROTTLE VALVE	
116	S12199000	1	エアホース4X2.5-23	AIR TUBE 4X2.5-23 (L=1430)	
117	S12178000	1	エアホース4X2.5-2	AIR TUBE 4X2.5-2 (L=130)	
118	S12104000	1	ユニオンワイ4	UNION-Y 4	
<コクナイヨウ /FOR DOMESTIC>					
83	S06857000	1	エアガンクミ	-----	
83-1	S06858000	1	エアガン	-----	
83-2	S06859000	1	カールホース	-----	
85	S04891000	1	チウカンニツプル1/4	-----	
<ユシュツヨウ /FOR EXPORT>					
84	140542001	1	-----	1/4PT CAP	

S. 空圧関係/Air pressure mechanism/Luftdruck/
 Mécanisme de la pression d'air/Mecanismo de la presión de aire

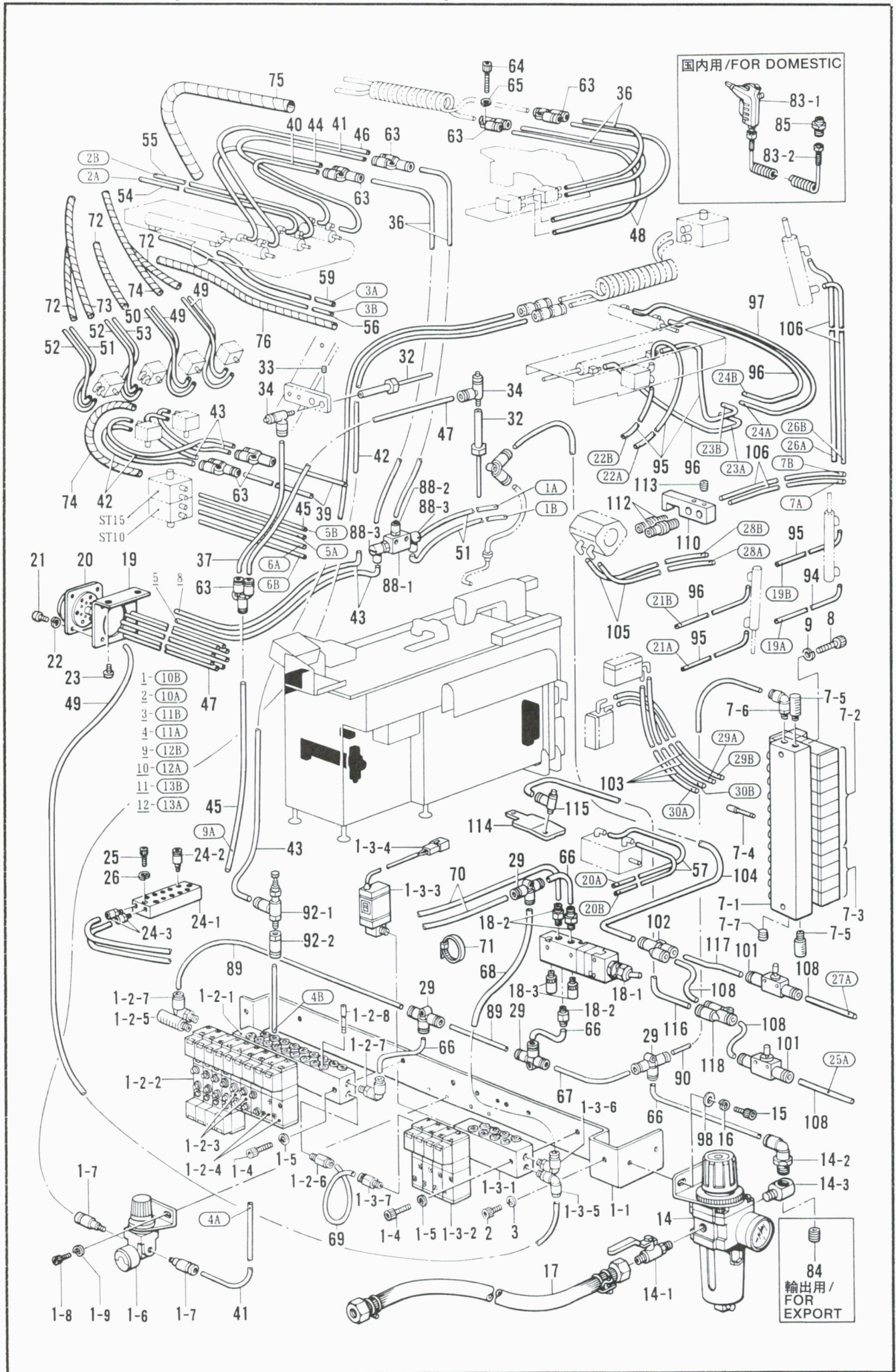

S. 空圧関係 / Air pressure mechanism / Luftdruck /
 Mécanisme de la pression d'air / Mecanismo de la presión de aire

REF.NO.	CODE	Q'TY	ヒンメイ	NAME OF PARTS	RMKS
34	S14328000	2	シホ"リハ"ン	THROTTLE VALVE	
36	S12178000	4	エア-ホ-ス4X2.5-2	AIR TUBE 4X2.5-2 (L=130)	
37	S12179000	1	エア-ホ-ス4X2.5-3	AIR TUBE 4X2.5-3 (L=190)	
39	S12181000	2	エア-ホ-ス4X2.5-5	AIR TUBE 4X2.5-5 (L=290)	
40	S12182000	1	エア-ホ-ス4X2.5-6	AIR TUBE 4X2.5-6 (L=340)	
41	S12183000	2	エア-ホ-ス4X2.5-7	AIR TUBE 4X2.5-7 (L=430)	
42	S12184000	3	エア-ホ-ス4X2.5-8	AIR TUBE 4X2.5-8 (L=480)	
43	S12185000	5	エア-ホ-ス4X2.5-9	AIR TUBE 4X2.5-9 (L=510)	
44	S12186000	1	エア-ホ-ス4X2.5-10	AIR TUBE 4X2.5-10 (L=520)	
45	S12187000	5	エア-ホ-ス4X2.5-11	AIR TUBE 4X2.5-11 (L=570)	
46	S12188000	1	エア-ホ-ス4X2.5-12	AIR TUBE 4X2.5-12 (L=600)	
47	S12189000	9	エア-ホ-ス4X2.5-13	AIR TUBE 4X2.5-13 (L=630)	
48	S12190000	2	エア-ホ-ス4X2.5-14	AIR TUBE 4X2.5-14 (L=310)	
49	S12191000	4	エア-ホ-ス4X2.5-15	AIR TUBE 4X2.5-15 (L=770)	
50	S12192000	1	エア-ホ-ス4X2.5-16	AIR TUBE 4X2.5-16 (L=780)	
51	S12193000	3	エア-ホ-ス4X2.5-17	AIR TUBE 4X2.5-17 (L=890)	
52	S12194000	2	エア-ホ-ス4X2.5-18	AIR TUBE 4X2.5-18 (L=920)	
53	S12195000	1	エア-ホ-ス4X2.5-19	AIR TUBE 4X2.5-19 (L=930)	
54	S12196000	1	エア-ホ-ス4X2.5-20	AIR TUBE 4X2.5-20 (L=1060)	
55	S12197000	1	エア-ホ-ス4X2.5-21	AIR TUBE 4X2.5-21 (L=1090)	
56	S12198000	1	エア-ホ-ス4X2.5-22	AIR TUBE 4X2.5-22 (L=1300)	
57	*	2	エア-ホ-ス4X2.5-15	AIR TUBE 4X2.5-15 (L=770)	
59	S12201000	1	エア-ホ-ス4X2.5-25	AIR TUBE 4X2.5-25 (L=1700)	
63	S12104000	7	ユニオンワイ4	UNION-Y 4	
64	018403022	3	アナホ"ルト4X30	BOLT 4X30	
65	028040242	3	ハ"ネサ"カ"ネ2-4	SPRING WASHER 2-4	
66	S12206000	4	エア-ホ-ス6X4-1	AIR TUBE 6X4-1 (L=50)	
67	S12207000	1	エア-ホ-ス6X4-2	AIR TUBE 6X4-2 (L=170)	
68	S12208000	1	エア-ホ-ス6X4-3	AIR TUBE 6X4-3 (L=200)	
69	S12209000	1	エア-ホ-ス6X4-4	AIR TUBE 6X4-4 (L=320)	
70	S12210000	2	エア-ホ-ス6X4-5	AIR TUBE 6X4-5 (L=400)	
71	S04159000	25	ハ"ント"1M	BAND 1M	
72	S12211000	3	スパ"イラル130S	SPIRAL (130S)	
73	S12212000	1	スパ"イラル290S	SPIRAL (290S)	
74	S12213000	2	スパ"イラル430S	SPIRAL (430S)	
75	S12214000	1	スパ"イラル640L	SPIRAL (640L)	
76	S12215000	1	スパ"イラル640S	SPIRAL (640S)	
88	S15561000	2	クイ"ツクエキ"ゾ"-ストクミ	QUICK EXHAUST ASSEMBLY	
88-1	S15562000	2	クイ"ツクエキ"ゾ"-スト	QUICE EXHAUST	
88-2	S11433000	2	ホ-スニツ"プル4M5	HOSE NIPPLE 4M5	
88-3	S12150000	4	ホ-スエル"ホ"M-5HL-4	TUBE ELBOW (M-5HL-4)	
89	S19585000	2	エア-ホ-ス6X4-6	AIR TUBE 6X4-6 (L=230)	
90	S24953000	1	エア-ホ-ス6X4-8	AIR TUBE 6X4-8(L=1400)	
92	S19971000	1	ケ"ン"アツ"ハ"ンM5-04クミ	PRESSER REDUCING VALVE M5-04 ASSEMBLY	
92-1	S19972000	1	ケ"ン"アツ"ハ"ンM5-04	PRESSER REDUCING VALVE M5-04	
92-2	S29240000	1	メスユニオン4-M5	FEMALE UNION 4-M5	
94	*	1	エア-ホ-ス4X2.5-15	AIR TUBE 4X2.5-15 (L=770)	
95	*	5	エア-ホ-ス4X2.5-17	AIR TUBE 4X2.5-17 (L=890)	
96	*	3	エア-ホ-ス4X2.5-20	AIR TUBE 4X2.5-20 (L=1060)	
97	*	1	エア-ホ-ス4X2.5-21	AIR TUBE 4X2.5-21 (L=1090)	
98	025060232	2	ヒラ"サ"カ"ネチユウ6	PLAIN WASHER 6	
101	S09197000	2	スピ-ト"コン"トローラ	SPEED CONTROLLER	
102	S12104000	1	ユニオンワイ4	UNION-Y 4	
103	S12200000	4	エア-ホ-ス4X2.5-24	AIR TUBE 4X2.5-24 (L=1600)	
104	S12198000	1	エア-ホ-ス4X2.5-22	AIR TUBE 4X2.5-22 (L=1300)	
105	S25051000	2	エア-ホ-ス4X2.5-30	AIR TUBE 4X2.5-30 (L=1250)	
106	S12197000	4	エア-ホ-ス4X2.5-21	AIR TUBE 4X2.5-21 (L=1060)	
108	S25054000	4	エア-ホ-ス4X2.5-33	AIR TUBE 4X2.5-33 (L=50)	
110	S25039001	1	ソケツ"トリツケ"イタ	SOCKET SET PLATE	
112	S25041000	2	ソケツ"ト	SOCKET	
113	014060632	3	アナ"トメ6X6ク"ホ"ミ	SET SCREW 6X6	

S. 空圧関係 / Air pressure mechanism / Luftdruck /
 Mécanisme de la pression d'air / Mecanismo de la presión de aire

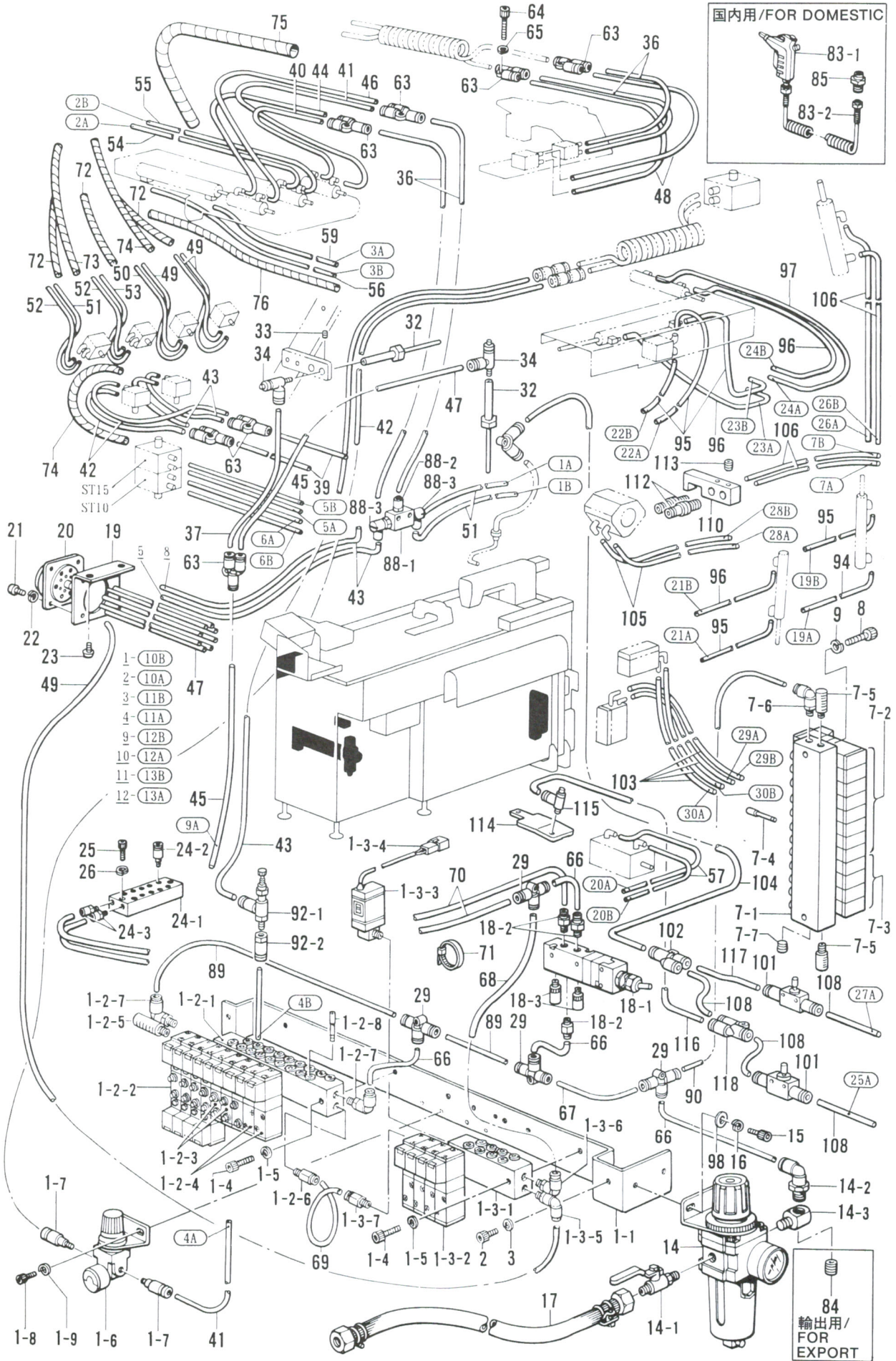
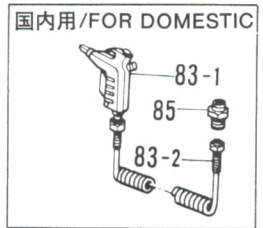

84
 輸出用 /
 FOR EXPORT

S. 空圧関係 / Air pressure mechanism / Luftdruck /
 Mécanisme de la pression d'air / Mecanismo de la presión de aire

REF.NO.	CODE	Q'TY	ヒンメイ	NAME OF PARTS	RMKS
1	S24937001	1	ハ"ルフ"クミJ	VALVE ASSEMBLY (J)	
1-1	S12155101	1	ハ"ルフ"トリツケイタ	VALVE SET PLATE	
1-2	S24938001	1	ハ"ルフ"9ヒタ"リクミ	VALVE 9 LEFT ASSEMBLY	
1-2-1	S19067000	1	マニホルト"9	MANIHOLD 9	
1-2-2	S12158000	4	ハ"ルフ"VZ3243-N	VALVE VZ3243-N	
1-2-3	S12160000	4	ハ"ルフ"VZ3143-N	VALVE VZ3143-N	
1-2-4	S12161000	1	ハ"ルフ"VZ3143	VALVE VZ3143	
1-2-5	140682001	1	サイレンサン	SILENCER	
1-2-6	S01522000	1	ハーフユニオン	HALF UNION	
1-2-7	S01542000	2	エルボ"ユニオン61	ELBOW UNION 61	
1-2-8	S04897000	1	メクラセン	BLIND CAP	
1-3	S24939000	1	ハ"ルフ"4クミ	VALVE 4 ASSEMBLY	
1-3-1	S24940000	1	マニホルト"4	MANIHOLD 4	
1-3-2	S12161000	4	ハ"ルフ"VZ3143	VALVE VZ3143	
1-3-3	S12164000	1	アツリヨクスイッチ	PRESSURE SWITCH	
1-3-4	152509000	1	ナイロンコネクタE	NYLON CONNECTOR (E)	
1-3-5	S04909000	1	エルボ"ユニオン	ELBOW UNION	
1-3-6	S01542000	1	エルボ"ユニオン61	ELBOW UNION 61	
1-3-7	S01522000	1	ハーフユニオン	HALF UNION	
1-4	018503022	4	アナホ"ルト5X30	BOLT 5X30	
1-5	028050242	4	ハ"ネサ"カ"ネ2-5	SPRING WASHER 2-5	
1-6	S12165000	1	レキ"ユレーター	REGULATOR	
1-7	S04905000	2	ハーフユニオン	HALF UNION	
1-8	018400832	2	アナホ"ルト4X8	BOLT 4X8	
1-9	028040242	2	ハ"ネサ"カ"ネ2-4	SPRING WASHER 2-4	
2	018060822	2	アナホ"ルト6X8	BOLT 6X8	
3	028060242	2	ハ"ネサ"カ"ネ2-6	SPRING WASHER 2-6	
7	*	1	ハ"ルフ"12クミ	VALVE 12 ASSEMBLY	
7-1	S24943000	1	マニホルト"12	MANIHOLD 12	
7-2	S12160000	8	ハ"ルフ"VZ3143-N	VALVE VZ3143-N	
7-3	S12161000	4	ハ"ルフ"VZ3143	VALVE VZ3143	
7-4	S04897000	2	メクラセン	BLIND CAP	
7-5	140682001	2	サイレンサン	SILENCER	
7-6	S01542000	1	エルボ"ユニオン61	ELBOW UNION 61	
7-7	153274001	1	1/8トメセン	CAP 1/8	
8	018503022	2	アナホ"ルト5X30	BOLT 5X30	
9	028050242	2	ハ"ネサ"カ"ネ2-5	SPRING WASHER 2-5	
14	S12166000	1	フィルターレキ"ユレータークミ	FILTER REGULATOR ASSEMBLY	
14-1	S09231000	1	ホ"ールハ"ルフ"1/4	BALL VALVE 1/4	
14-2	S04896000	1	エルボ"ユニオン	ELBOW UNION	
14-3	153252000	1	PTチース"	PT-JOINT	
15	018061022	2	アナホ"ルト6X10	BOLT 6X10	
16	028060242	2	ハ"ネサ"カ"ネ2-6	SPRING WASHER 2-6	
17	149796001	1	ゴムホースカナグ"ツキ	AIR TUBE WITH CONNECTOR	
18	S12168000	1	メカニカルハ"ルフ"クミ	MECHANICAL VALVE ASSEMBLY	
18-1	S12169000	1	メカニカルハ"ルフ"	MECHANICAL VALVE	
18-2	S01522000	3	ハーフユニオン	HALF UNION	
18-3	S12170000	2	サイレンサ	SILENCER	
19	S12171001	1	カクヘキイター1	BULKHEAD PLATE	
20	S12172000	1	マルチコネクタS	MULTI CONNECTOR (S)	
21	062400812	4	ナヘ"コ4X8	SCREW 4X8	
22	028040242	4	ハ"ネサ"カ"ネ2-4	SPRING WASHER 2-4	
23	062680812	2	ナヘ"コ437-40X8	SCREW 437X8	
24	S12167000	1	マニホルト"12クミ	MANIFOLD 12 ASSEMBLY	
24-1	S12173000	1	マニホルト"	MANIFOLD	
24-2	S04905000	12	ハーフユニオン	HALF UNION	
24-3	S12174000	2	ホースニツプル6M5	HOSE NIPPLE 6M5	
25	018401622	2	アナホ"ルト4X16	BOLT 4X16	
26	028040242	2	ハ"ネサ"カ"ネ2-4	SPRING WASHER 2-4	
29	S12175000	4	チース"06	T-JOINT 06	
32	S12176000	2	エアフ"ロワー	AIR BLOWER	
33	014400522	2	アナクホ"ミ4X5	SET SCREW 4X5	

S. 空圧関係 / Air pressure mechanism / Luftdruck /
 Mécanisme de la pression d'air / Mecanismo de la presión de aire

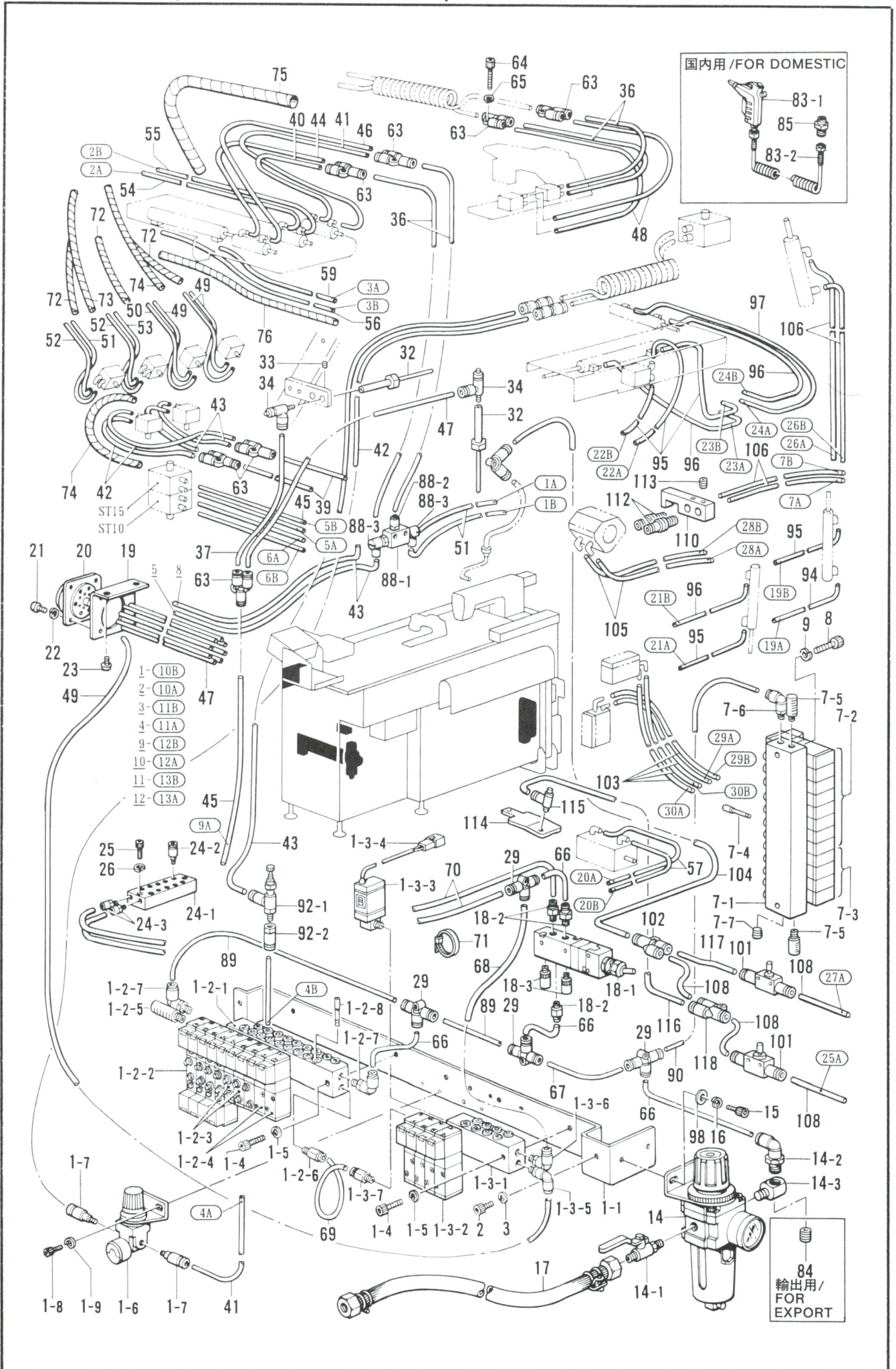

R. 糸切り関係/Thread trimmer mechanism/Fadenabschneidevorrichtung/
 Mécanisme de coupe-fil/Mecanismo de la cortadura de hilos

REF.NO.	CODE	Q'TY	ヒンメイ	NAME OF PARTS	RMKS
1	S00337001	1	イトキリカム	THREAD TRIMMER CAM	
2	154567000	2	カンザ"5.3	WASHER 5.3	
3	014771022	2	アナトメネジ"6.35クホ"ミ	SET SCREW 6.35	
4	159540001	1	コテイハ	FIXED KNIFE	
5	102843004	1	サラネジ"3.57	SCREW 3.57	
6	013660612	1	トメネジ"3.18クホ"ミ	SET SCREW 3.18	
7	S02643001	1	イトサハ"キ	LOWER THREAD FINGER	
8	100645003	1	ザ"カ"ネ	WASHER	
9	062400812	1	ナヘ"コ4X8	SCREW 4X8	
10	156619001	1	イトキリホルダ"	MOVABLE KNIFE HOLDER	
11	156620000	1	スラストザ"カ"ネ	THRUST WASHER	
12	048170145	1	トメワジ"クヨウC17	STOP RING C17	
13	S11926001	1	ザ"カ"ネ	WASHER	
14	159541001	1	イト"ウハ	MOVABLE KNIFE	
15	148537001	2	サラネジ"4.37	SCREW 4.37	
16	154576001	1	イトキリレンカン	THREAD TRIMMER CONNECT ROD	
17	151987001	2	タ"ンネジ"4.37	STUD SCREW 4.37	
18	102571003	1	ナツト4.37	NUT 4.37	
19	159542101	1	イトキリレハ"ー	THREAD TRIMMER LEVER	
20	154578000	1	レハ"ーストツハ°	THREAD TRIMMER LEVER STOPPER	
21	062711412	1	ナヘ"コ476-32X14	SCREW 476X14	
22	156623001	1	イトキリレハ"ーハ"ネ	SPRING	
23	S02647001	1	フタマタジ"ク	FORKED SHAFT	
24	S02648001	1	カラー	COLLAR	
25	154581001	1	フタマタジ"クメタル	FORKED SHAFT BUSH	
26	014400822	1	アナトメネジ"4クホ"ミ	SET SCREW 4	
27	154582001	1	イトキリカムレハ"ークミ	THREAD TRIMMER CAM LEVER ASSEMBLY	
28	154590001	1	コロシ"クCクミ	ROLLER SHAFT (C) ASSEMBLY	
29	105234003	1	ナツト4.37	NUT 4.37	
30	100251001	1	トメネジ"6.35	SET SCREW 6.35	
31	154593001	1	イトキリカムレハ"ーシ"ク	THREAD TRIMMER CAM LEVER SHAFT	
32	154594000	1	カラー	COLLAR	
33	154595001	1	カムレハ"ーモト"シハ"ネ	SPRING	
34	154596000	1	イトキリカムレハ"ークツシオン	CUSHION	
35	110367001	1	ザ"カ"ネ	WASHER	
36	048060342	1	トメワE6	STOP RING E6	
37	S11927009	1	イトキリソレノイト"クミ	THREAD TRIMMER SOLENOID ASSEMBLY	
37-1	S11928009	1	イトキリソレノイト"	THREAD TRIMMER SOLENOID	
37-2	143488000	1	ナイロンコネクター	NYLON CONNECTOR	
38	154598001	1	イトキリソレノイト"タ"イ	THREAD TRIMMER SOLENOID BRACKET	
39	154599000	1	ソレノイト"クツシオン	SOLENOID CUSHION	
40	S02652001	1	ザ"カ"ネ	WASHER	
41	S23836001	1	ソレノイト"レハ"ークミ	SOLENOID LEVER ASSEMBLY	
41-1	014680622	1	アナトメネジ"4.37クホ"ミ	SET SCREW 4.37	
42	110201001	2	シメネジ"6.35	SCREW 6.35	
43	S11929001	1	イトキリシ"クメタルL	THREAD TRIMMER SHAFT BUSH (L)	
44	S11930001	1	イトキリシ"クメタルR	THREAD TRIMMER SHAFT BUSH (R)	
45	014400822	2	アナトメネジ"4クホ"ミ	SET SCREW 4	
46	S02657001	1	コード"オサエ	CORD HOLDER	
47	062300612	1	ナヘ"コ3X6	SCREW 3X6	

R. 糸切り関係 / Thread trimmer mechanism / Fadenabschneidevorrichtung /
 Mécanisme de coupe-fil / Mecanismo de la cortadura de hilos

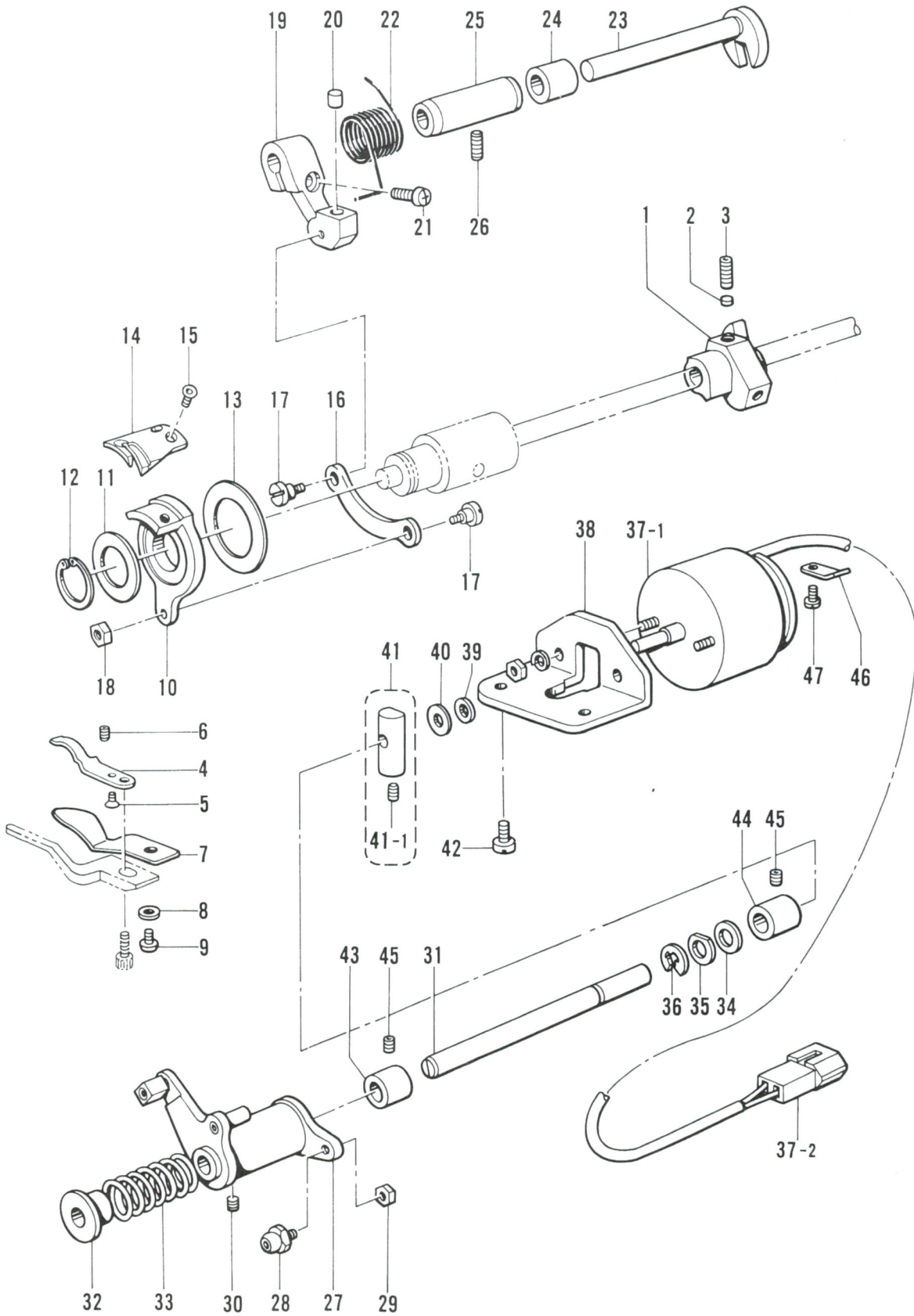

Q. 糸巻関係/Bobbin winder mechanism/Spuler/

Mécanisme du bobineur/Mecanismo del devanador de la canilla

REF.NO.	CODE	Q'TY	ヒンメイ	NAME OF PARTS	RMKS
1	S17701009	1	イトマキソウチクミ	BOBBIN WINDER EQUIPMEINT ASSEMBLY	
1-1	S12027109	1	イトマキベース	BOBBIN WINDER BASE	
1-2	004300513	4	+ サラネジ"3X5	SCREW 3X5	
1-3	215083001	3	+ ナヘ"セツト3X6D	WASHER SCREW 3X6D	
1-5	152358001	1	イトマキシ"ク	BOBBIN WINDER SHAFT	
1-6	014300332	2	アナクホ"ミ3X3	SET SCREW 3X3	
1-7	154024001	1	ホ"ヒン"オサエ	BOBBIN PRESSER	
1-8	154092001	1	イトマキツメタ"ンツキ	BOBBIN WINDER CLAW	
1-9	014680422	2	アナトメネジ"4.37クホ"ミ	SET SCREW 4.37	
1-10	152361001	1	イトマキレハ"ー	BOBBIN WINDER LEVER	
1-11	152362001	1	イトマキタ"ンネジ"	BOBBIN WINDER STUD SCREW	
1-12	111942001	1	イタハ"ネ	PLATE SPRING	
1-13	111943001	1	イタハ"ネサ"ガ"ネ	PLATE SPRING WASHER	
1-14	060660512	1	ハ"イント"318-40X5	SCREW 318X5	
1-15	152363001	1	ネジ"リハ"ネA	TWIST SPRING (A)	
1-16	047301042	1	スプリング"ピン	SPRING PIN	
1-17	152364001	2	カラー	COLLAR	
1-18	145571101	1	イトマキアンナイト"イクミ	BOBBIN WINDER GUIDE BRACKET ASSEMBLY	
1-19	145446001	2	イトチヨウシサラ	TENSION DISC	
1-20	100401001	1	イトチヨウシハ"ネ	TENSION SPRING	
1-21	100136001	1	イトチヨウシナツト	TENSION NUT	
1-22	146197001	1	イトツカミクミ	THREAD CLAMP ASSEMBLY	
1-23	025040232	2	ヒラサ"ガ"ネチユウ4	PLAIN WASHER 4	
1-24	028040242	1	ハ"ネサ"ガ"ネ2-4	SPRING WASHER 2-4	
1-25	062401012	1	ナヘ"コM4X10	SCREW M4X10	
1-26	021400202	1	2シユナツト4	NUT 4	
1-27	S19522001	1	イトマキモータークミ	BOBBIN WINDER GUIDE BRACKET ASSEMBLY	
1-27-1	S16667000	1	イトマキモータ	BOBBIN WINDER MOTOR	
1-27-2	152507000	1	マイクロスイッチD	MICRO SWITCH (D)	
1-27-3	152508000	1	マイクロアクチエータ	MICRO ACTUATOR	
1-27-4	152509000	1	ナイロンコネクタE	NYLON CONNECTOR (E)	
1-27-5	552851001	2	ピンターミナル#1854	TERMINAL PIN #1854	
1-28	152645001	1	ホ"ヒン"オサエイタ	BOBBIN HOLD PLATE	
1-29	062300616	1	ナヘ"コM3X6	SCREW M3X6	
1-30	025030233	1	ヒラサ"ガ"ネチユウ3	PLAIN WASHER 3	
1-31	158597001	1	イトマキストッパ"ー	BOBBIN WINDER STOPPER	
1-32	158598009	1	イトマキアンナイトリツケイタ	BOBBIN WINDER GUIDE SET PLATE	
1-33	062401012	1	ナヘ"コM4X10	SCREW M4X10	
1-34	028040242	1	ハ"ネサ"ガ"ネ2-4	SPRING WASHER 2-4	
1-35	S16669000	1	プロテクタ0.5A	PROTECTOR 0.5A	
2	062400806	4	ナヘ"コ4X8	SCREW M4X8	
3	028040243	4	ハ"ネサ"ガ"ネ2-4	SPRING WASHER 2-4	

Q. 糸巻関係/Bobbin winder mechanism/Spuler/
 Mécanisme du bobineur/Mecanismo del devanador de la canilla

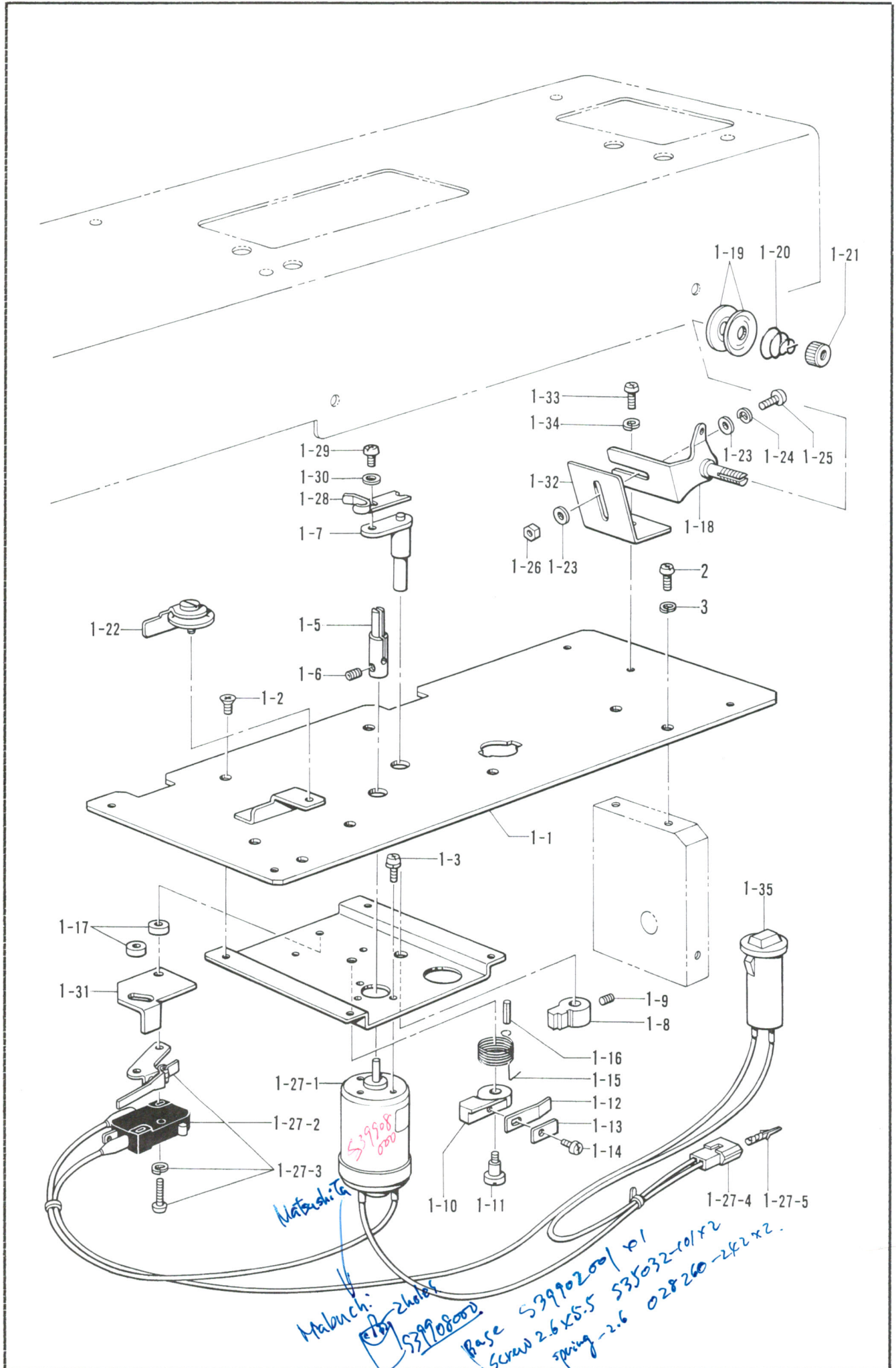

P. 糸通シ関係 / Threading mechanism / Fadenführungsrichtung /
 Mécanisme de l'enfilage / Mecanismo del enhebrado

REF.NO.	CODE	Q'TY	ヒンメイ	NAME OF PARTS	RMKS
39	S24936001	1	アームイトアンナイシタ	ARM THREAD GUIDE LOWER	
40	112751002	1	シメネジ"3.57	SCREW 3.57	
41	S24962001	1	イトトオシイタ	THREADING PLATE	

P. 糸通シ関係 / Threading mechanism / Fadenführungsrichtung /
 Mécanisme de l'enfilage / Mecanismo del enhebrado

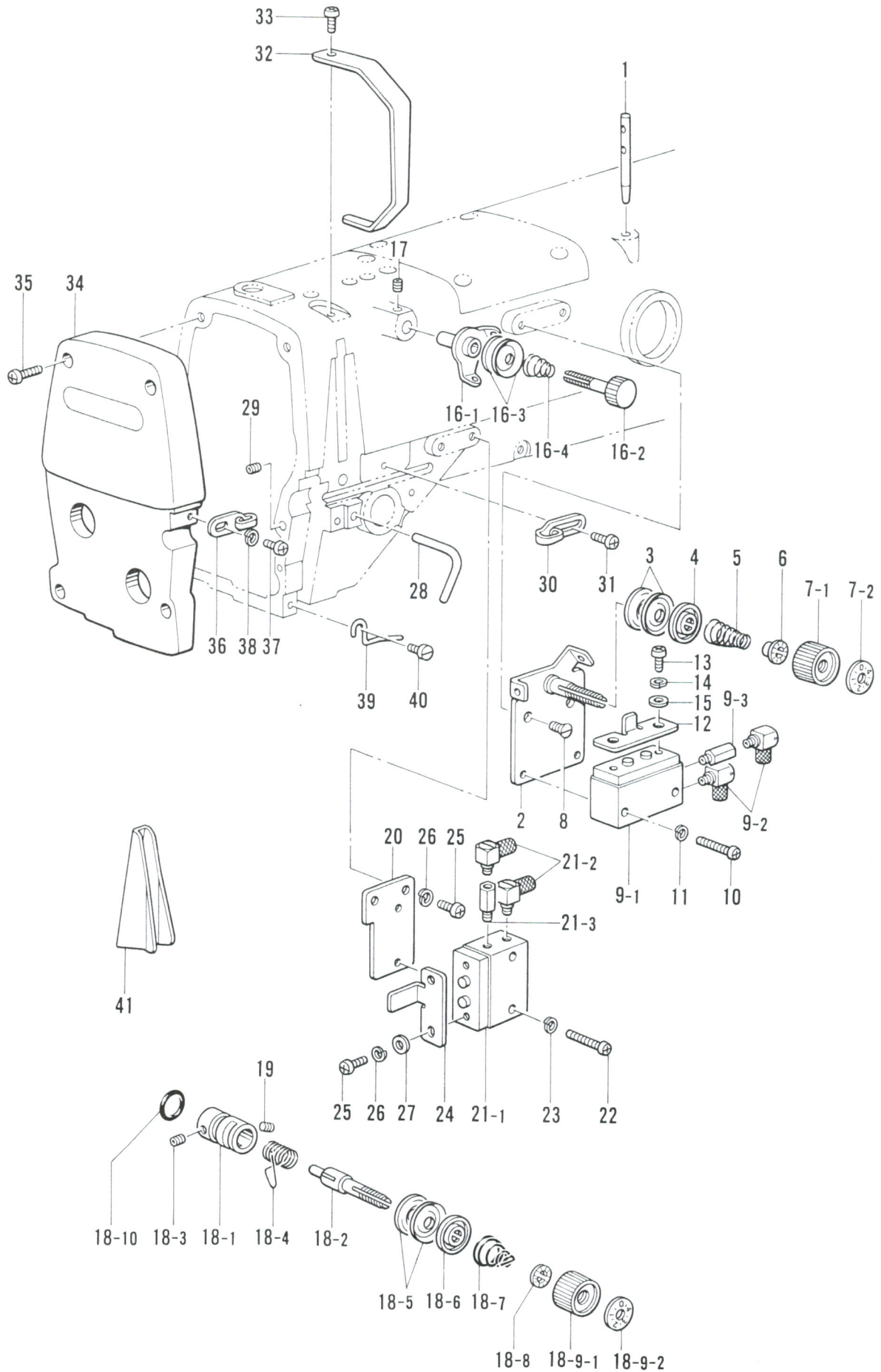

P. 糸通シ関係 / Threading mechanism / Fadenführungsvorrichtung /
 Mécanisme de l'enfilage / Mecanismo del enhebrado

REF.NO.	CODE	Q'TY	ヒンメイ	NAME OF PARTS	RMKS
1	147557101	1	イトタテホ"ウ	SPOOL PIN	
2	S24927001	1	イトチヨウシクミ	THREAD TENSION ASSEMBLY	
3	145446001	2	イトチヨウシサラ	TENSION DISC	
4	159805001	1	イトチヨウシサラオサエ	TENSION DISC PRESSER	
5	148851001	1	ハリイトチヨウシハ"ネ	TENSION SPRING	
6	144105000	1	チヨウシハ"ネウエサ"カ"ネ	SPRING WASHER	
7	S11182009	1	イトチヨウシナツクミ	THREAD TENSION NUT ASSEMBLY	
7-1	S11183009	1	チヨウセツツマミ	CONTROL DIAL	
7-2	S11184009	1	イトチヨウシメモリイタ	TENSION ADJUST SCALE PLATE	
8	100032003	2	サラネジ"4.37	SCREW 4.37	
9	S24929000	1	ツインロッド"シリンドラ"ークミ	TWIN ROD CYLINDER ASSEMBLY	
9-1	S12103000	1	ツインロッド"シリンドラ"ー	TWIN ROD CYLINDER	
9-2	S12150000	2	ホースエルボ"M-5HL-4	TUBE ELBOW (M-5HL-4)	
9-3	S24930000	1	エンチヨウツキ"テM-5J	EXTENDED JOINT M-5J	
10	062402016	2	ナヘ"コM4X20	SCREW M4X20	
11	028040243	2	ハ"ネサ"カ"ネ2-4	SPRING WASHER 2-4	
12	S24931001	1	サラワリツメ	CLAW	
13	062400806	2	ナヘ"コ4X8	SCREW M4X8	
14	028040243	2	ハ"ネサ"カ"ネ2-4	SPRING WASHER 2-4	
15	025040233	2	ヒラサ"カ"ネチユウ4	PLAIN WASHER 4	
16	183378001	1	プレテンションクミB	PRE-TENSION ASSEMBLY (B)	
16-1	S02611001	1	イトアンナイ	THREAD GUIDE	
16-2	S02612001	1	イトアンナイチヨウシホ"ウ	PRE-TENSION STUD	
16-3	144504001	2	イトアンナイサラ	THREAD GUIDE DISC	
16-4	154562001	1	プレテンションハ"ネB	PRE-TENSION SPRING (B)	
17	014400522	1	アナクホ"ミ4X5	SET SCREW 4X5	
18	183514009	1	イトチヨウシホ"ウタ"イクミ	THREAD TENSION BRACKET ASSEMBLY	
18-1	S03254001	1	イトチヨウシホ"ウタ"イ	THREAD TENSION BRACKET	
18-2	116922001	1	イトチヨウシホ"ウ	TENSION STUD	
18-3	100402004	1	トメネジ"3.57	SET SCREW 3.57	
18-4	S02620001	1	イトトリハ"ネ	SPRING	
18-5	145446001	2	イトチヨウシサラ	TENSION DISC	
18-6	159805001	1	イトチヨウシサラオサエ	TENSION DISC PRESSER	
18-7	S04632001	1	イトチヨウシハ"ネ	TENSION SPRING	
18-8	S12441001	1	チヨウシハ"ネウエサ"カ"ネ	WASHER	
18-9	S11182009	1	イトチヨウシナツクミ	THREAD TENSION NUT ASSEMBLY	
18-9-1	S11183009	1	チヨウセツツマミ	CONTROL DIAL	
18-9-2	S11184009	1	イトチヨウシメモリイタ	TENSION ADJUST SCALE PLATE	
18-10	114294001	1	Oリング"	O RING	
19	103950003	1	トメネジ"5.95	SET SCREW 5.95	
20	S24932001	1	シリンドラ"ササエイタ	CYLINDER SUPPORT PLATE	
21	S24929000	1	ツインロッド"シリンドラ"ークミ	TWIN ROD CYLINDER ASSEMBLY	
21-1	S12103000	1	ツインロッド"シリンドラ"ー	TWIN ROD CYLINDER	
21-2	S12150000	2	ホースエルボ"M-5HL-4	TUBE ELBOW (M-5HL-4)	
21-3	S24930000	1	エンチヨウツキ"テM-5J	EXTENDED JOINT M-5J	
22	062402016	2	ナヘ"コM4X20	SCREW M4X20	
23	028040243	2	ハ"ネサ"カ"ネ2-4	SPRING WASHER 2-4	
24	S24933001	1	サラワリツメ	CLAW	
25	062401006	4	ナヘ"コ4X10	SCREW M4X10	
26	028040243	4	ハ"ネサ"カ"ネ2-4	SPRING WASHER 2-4	
27	025040233	2	ヒラサ"カ"ネチユウ4	PLAIN WASHER 4	
28	116112001	1	イトアンナイ	THREAD GUIDE	
29	014400822	1	アナトメネジ"4クホ"ミ	SET SCREW 4	
30	145522001	1	アームイトアンナイR	ARM THREAD GUIDE (R)	
31	060670612	1	ハ"イント"357-40X6	SCREW 357X6	
32	S24934009	1	テンヒンカハ"ー	THREAD TAKE-UP COVER	
33	062400812	1	ナヘ"コ4X8	SCREW 4X8	
34	S24935009	1	メンイタ	FACE PLATE	
35	062401212	4	ナヘ"コ4X12	SCREW 4X12	
36	S02617001	1	メンイタイトアンナイ	FACE PLATE THREAD GUIDE	
37	060670612	1	ハ"イント"357-40X6	SCREW 357X6	
38	028350242	1	ハ"ネサ"カ"ネ2-3.5	SPRING WASHER 2-3.5	

P. 糸通シ関係/Threading mechanism/Fadenführungsrichtung/
 Mécanisme de l'enfilage/Mecanismo del enhebrado

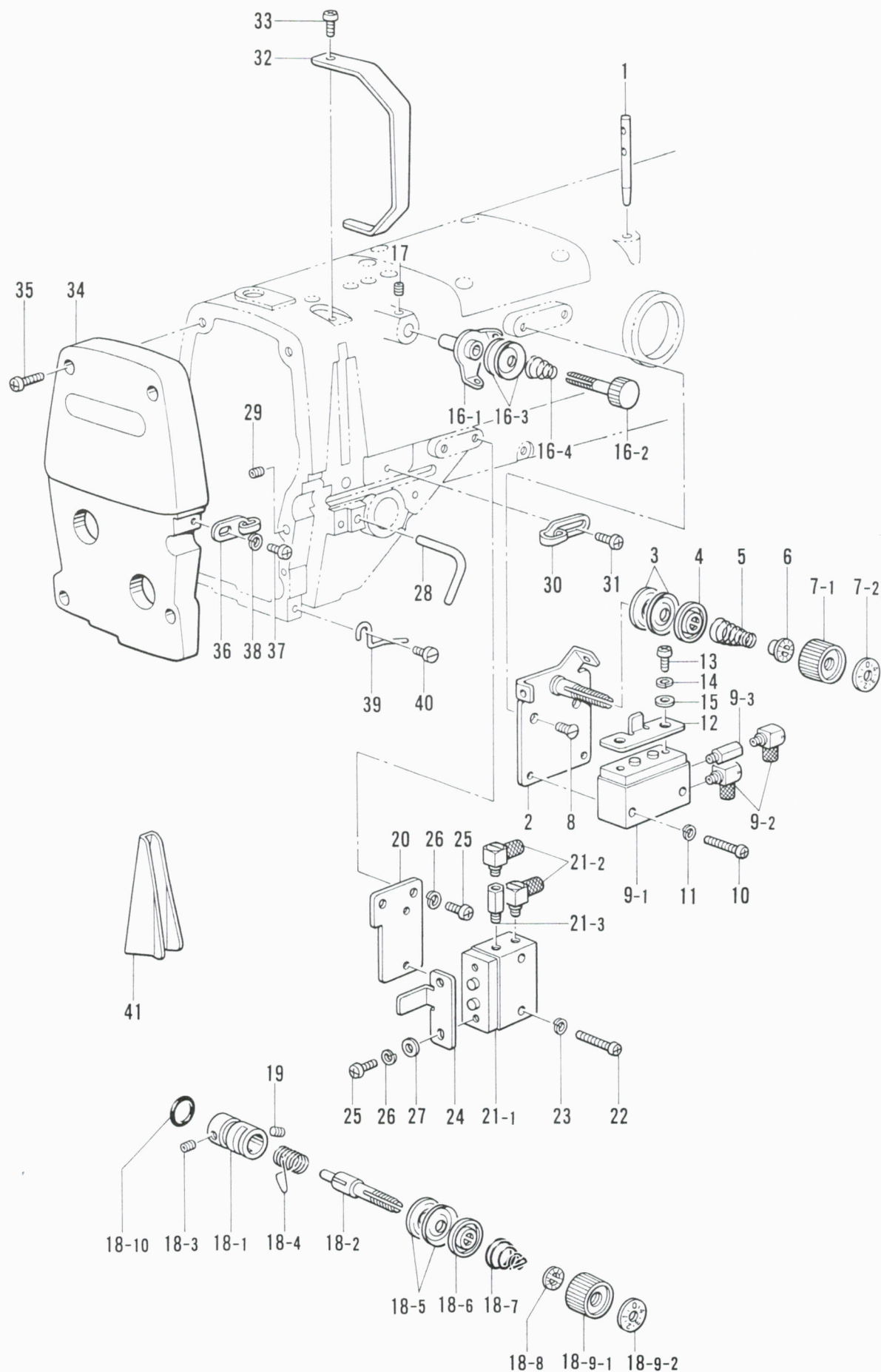

N. 給油・潤滑関係 / Lubrication / Schmierung /
Lubrication / Lubricación

REF.NO.	CODE	Q'TY	ヒンメイ	NAME OF PARTS	RMKS
64	110558001	4	Oリング	O RING	
65	S24924001	1	アブ"ラカハ"ー	OIL COVER	
66	018400822	2	アナホ"ルト4X8	BOLT 4X8	
67	028040242	2	ハ"ネサ"カ"ネ2-4	SPRING WASHER 2-4	
68	S12043000	2	エルホ"ユニオン	ELBOW UNION	
69	S11946000	1	ヒ"ニルチューブ"(L=1350)	OIL TUBE (L=1350)	
70	S11947000	1	ヒ"ニルチューブ"(L=800)	OIL TUBE (L=800)	
71	S04159000	2	ハ"ント"1M	BAND 1M	
72	S11949000	1	ゴ"ムフ"ツシユ	RUBBER BUSH	
73	S19523201	1	チューブ"ササエ	TUBE SUPPORT	
74	S12483000	1	チース"ユニオン	T-UNION	
75	S12484000	1	ヒ"ニルチューブ"(L=350)	OIL TUBE (L=350)	
76	154468001	1	ハイユク"チ	OIL FEEDING	
77	144508001	1	ホ"リオイルーノス"ルトメ	CAP	
78	106147002	1	ナツト7.94	NUT 7.94	
79	114486002	1	ホ"リオイルータイ	OILER	
80	133172003	1	アブ"ラサシタ"イ	OIL BRACKET	
81	008400806	1	+トラスコ4X8	SCREW 4X8	
82	S12482009	1	オイルータイトリツケイタ	OILER SET PLATE	
83	S12481000	2	ナイラツチ	NYLATCH	
84	S11848000	1	コート"クランプ"7-L	CORD CLAMP (7-L)	
85	149547000	1	コート"オサエ4N	CORD HOLDER (4N)	
86	018400832	2	アナホ"ルト4X8	BOLT 4X8	
87	028040242	2	ハ"ネサ"カ"ネ2-4	SPRING WASHER 2-4	
88	025040233	1	ヒラサ"カ"ネチユウ4	PLAIN WASHER 4	
89	062400806	1	ナヘ"コ4X8	SCREW M4X8	
90	145624000	4	フェルト	FELT	

N. 給油・潤滑関係 / Lubrication / Schmierung /
Lubrification / Lubricación

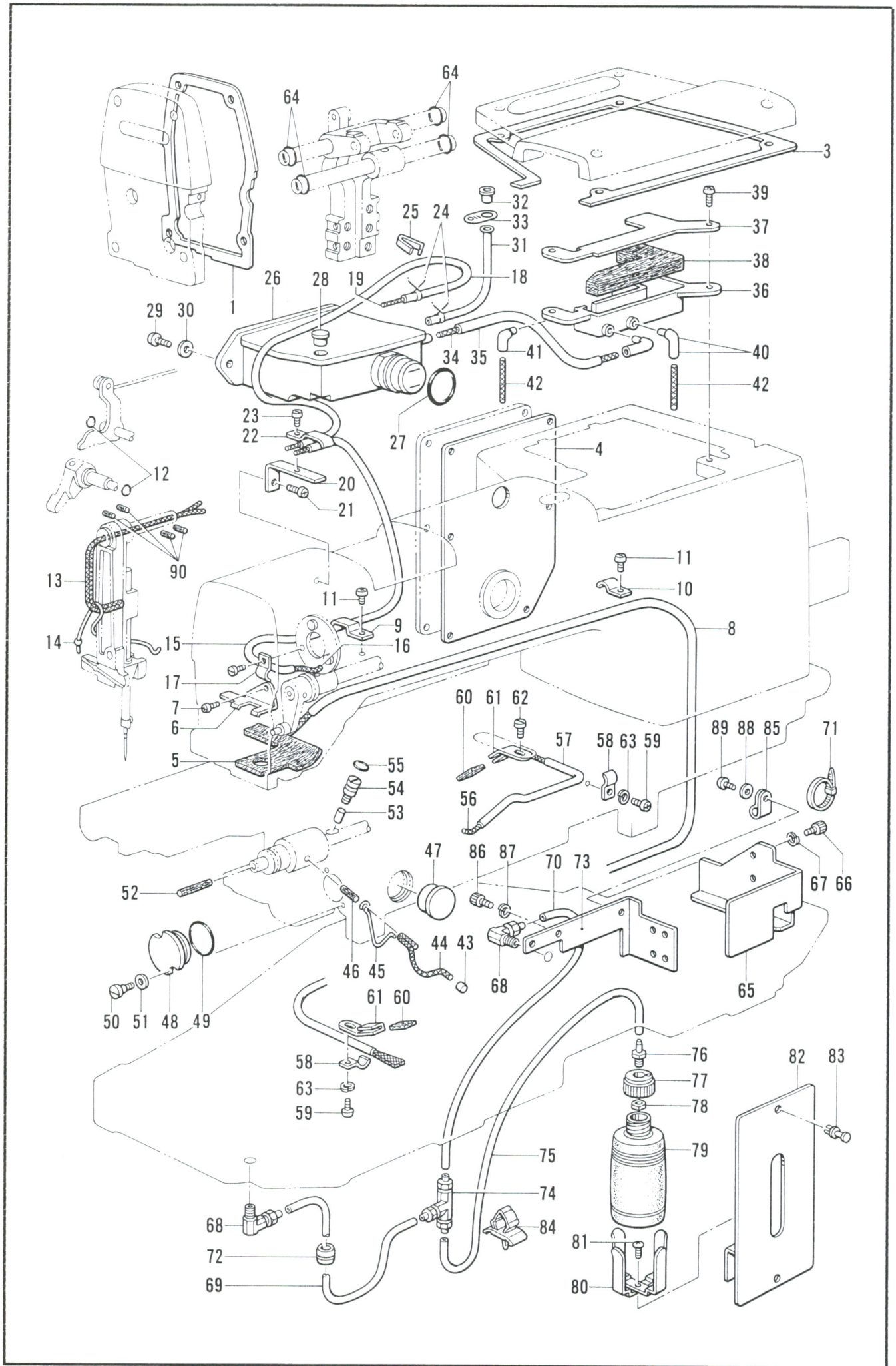

N. 給油・潤滑関係/Lubrication/Schmierung/
Lubrication/Lubricación

REF.NO.	CODE	Q'TY	ヒンメイ	NAME OF PARTS	RMKS
1	S24909000	1	メンイタハ°ツキン	FACE PLATE PACKING	
3	S24910000	1	ウフフ"タハ°ツキン	TOP COVER PACKING	
4	S24911000	1	ガ"フイタハ°ツキン	REAR COVER PACKING	
5	S24912000	1	スイアゲ"フェルトクミ	SUCTION FELT ASSEMBLY	
6	S24915001	1	スイアゲ"フェルトササエ	SUCTION FELT SUPPORT	
7	062670612	1	ナヘ"コ357-40X6	SCREW 357X6	
8	S24916000	1	ヒ"ニルチューブ"(L=680)	OIL TUBE (L=680,4X6)	
9	S02702001	1	コート"オサエU2	CORD HOLDER U2	
10	140647001	1	コート"オサエ	CORD HOLDER	
11	062300612	2	ナヘ"コ3X6	SCREW 3X6	
12	081001670	2	Oリング"PW1	O RING PW1	
13	S24917000	1	クミヒモ4X4 (L=470)	WICK (L=470,4X4)	
14	159561001	2	リリアンクミヒモ	WICK	
15	S24925000	1	ヒ"ニルチューブ"(L=200)	OIL TUBE (L=200,3X5)	
16	S24926000	1	クミヒモ3X3 (L=350)	WICK (L=350,3X3)	
17	S00955001	1	パイプ"ササエイタ	PIPE SUPPORT PLATE	
18	S24918000	1	ヒ"ニルチューブ"(L=270)	OIL TUBE (L=270,3X5)	
19	S24919000	1	クミヒモ3X3 (L=470)	WICK (L=470,3X3)	
20	S24920001	1	チューブ"ササエ	TUBE SUPPORT	
21	062400812	1	ナヘ"コ4X8	SCREW 4X8	
22	S02702001	1	コート"オサエU2	CORD HOLDER U2	
23	062300612	1	ナヘ"コ3X6	SCREW 3X6	
24	S07876001	2	チューブ"ストツハ°	TUBE CLAMP	
25	S07469001	1	チューブ"カシメ	TUBE CALKING	
26	S07450109	1	オイルタンククミ	OIL TANK ASSEMBLY	
27	081030070	1	Oリング"P30	O RING P30	
28	104821009	1	メクラセン	OIL CAP	
29	062711012	2	ナヘ"コ476-32X10	SCREW 476X10	
30	025710232	2	ヒラサ"カ"ネチユウ4.76	PLAIN WASHER 4.76	
31	S11945000	1	ヒ"ニルチューブ"(L=100)	OIL TUBE (L=100,3X5)	
32	112758009	1	ヘ"ツト"オイルフタ	OIL CAP	
33	S24921009	1	オイルシート	OIL SEAT	
34	S24917000	1	クミヒモ4X4 (L=470)	WICK (L=470,4X4)	
35	S24922000	1	ヒ"ニルチューブ"(L=100)	OIL TUBE (L=100,5X8)	
36	159189000	1	トウシンヘ"ースB	WICK BASE (B)	
37	159190001	1	トウシンヘ"ースBフタ	WICK BASE (B) COVER	
38	159191000	1	トウシンヘ"ースBフェルト	FELT	
39	062401012	2	ナヘ"コM4X10	SCREW M4X10	
40	159192000	2	オイルパイプ"A	OIL PIPE (A)	
41	159193000	1	オイルパイプ"B	OIL PIPE (B)	
42	S24923000	1	クミヒモ4X4 (L=270)	WICK (L=270,4X4)	
43	157843001	1	ゴムセン6X6	OIL CAP 6X6	
44	157840000	1	クミヒモ3X3 (L=100)	WICK (L=100,3X3)	
45	S11916001	1	クミヒモササエ	WICK SUPPORT	
46	S11915000	1	フェルト5X16	FELT 5X16	
47	152948001	1	オイルホ°ツト"マト"	OIL GAUGE WINDOW	
48	157844000	1	アブ"ラマト"	OIL GAUGE WINDOW	
49	081024070	1	Oリング"P24	O RING P24	
50	153112001	2	タ"ンネジ"3.57	STUD SCREW 3.57	
51	140208001	2	サ"カ"ネ	WASHER	
52	S11918000	1	フェルト	FELT	
53	S07478000	1	ゴムオサエ	RUBBER PRESSER	
54	S11917001	1	オイルチヨウセツツネシ"	ADJUST SCREW	
55	081005670	1	Oリング"PW5	O RING PW5	
56	S11909000	1	クミヒモ3X3 (L=250)	WICK (L=250,3X3)	
57	S11919000	1	ヒ"ニルチューブ"(L=160)	OIL TUBE (L=160)	
58	140647001	2	コート"オサエ	CORD HOLDER	
59	062300612	2	ナヘ"コ3X6	SCREW 3X6	
60	S11914000	2	フェルト	FELT	
61	S11920001	2	フェルトササエ	FELT SUPPORT	
62	106629002	1	シメネジ"4.37	SCREW 4.37	
63	028030242	2	ハ"ネサ"カ"ネ2-3	SPRING WASHER 2-3	

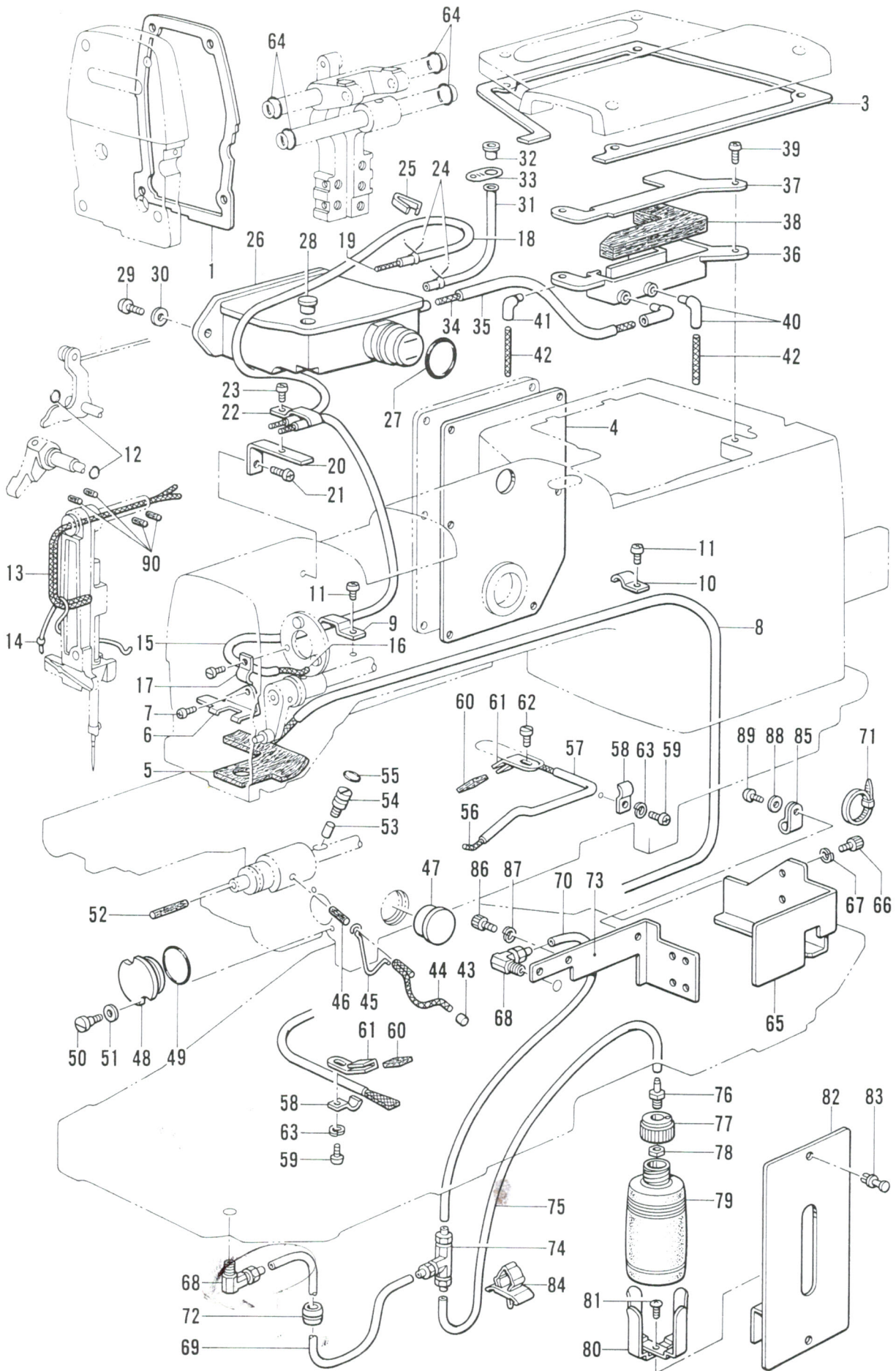

M. カマ関係 / Rotary hook mechanism / Greifervorrichtung /
Mécanisme du crochet rotatif / Mecanismo del cangrejo

REF.NO.	CODE	Q'TY	ヒンメイ	NAME OF PARTS	RMKS
1	159745100	1	Dタイミング"プー"リクミ	LOWER TIMING PULLEY ASSEMBLY	
2	014760622	4	アナトメネシ"5.95	SET SCREW 5.95	
3	S24901001	1	シタシ"ク	LOWER SHAFT	
4	S11921000	1	タマシ"クウケ6002DDU	BALL BEARING 6002DDU	
5	072620260	1	タマシ"クウケ6202VVC2	BALL BEARING 6202VVC2	
8	048350242	1	トメワアナヨウC35	STOP RING C35	
9	S11893001	1	タマシ"クウケオサエ	BALL BEARING PRESSER	
10	062401012	3	ナヘ"COM4X10	SCREW M4X10	
11	048150142	1	トメワシ"クヨウC15	STOP RING C15	
12	S11894001	1	スパ"イラルキ"ヤ	SPIRAL GEAR	
13	014770622	3	アナトメネシ"6.35クホ"ミ	SET SCREW 6.35	
14	S24902001	1	カマシ"ク	ROTARY HOOK SHAFT	
15	S11896001	1	カマシ"クメタル	ROTARY HOOK SHAFT BUSH	
16	014400822	1	アナトメネシ"4クホ"ミ	SET SCREW 4	
17	183532001	1	セツトカラークミ	SET COLLAR ASSEMBLY	
17-1	101706001	2	トメネシ"6.35	SET SCREW 6.35	
18	S11898000	1	キト"ウリン	DRIVE TUMBLER	
19	S11899000	1	ニート"ルヘ"アリンク"	NEEDLE BEARING	
20	115007001	1	サ"カ"ネ	WASHER	
21	159324001	1	ウチカマトメ	BOBBIN CASE HOLDER POSITION BRACKET	
22	018401422	1	アナホ"ルト4X14	BOLT 4X14	
23-1	S24903001	1	コウソクカマ1.7	ROTARY HOOK ASSEMBLY 1.7	
23-2	S24903901	1	コウソクカマ1.7ハコクミ	ROTARY HOOK 1.7 BOX ASSEMBLY	
24	S24904001	1	ホ"ヒ"ンケースクミ1.7	BOBBIN CASE ASSEMBLY 1.7	
24-1	S24905001	1	ホ"ヒ"ンケースチヨウシハ"ネ	TENSION SPRING	
24-2	183809001	1	チヨウシハ"ネチヨウセツネシ"	ADJUST SCREW	
24-3	183810001	1	チヨウシハ"ネトメネシ"	SET SCREW	
24-4	183811001	1	クウテンホ"ウシハ"ネ	BOBBIN TENSION SPRING	
25	S23848001	1	ホ"ヒ"ン1.7	BOBBIN 1.7	
26	048220242	1	トメワアナヨウC22	STOP RING C22	
27	072060860	1	タマシ"クウケ608VV	BALL BEARING 608VV	
28	S11924000	1	タマシ"クウケ608DDW1	BALL BEARING 608DDW1	
31	S11900001	1	ピ"ニオン	PINION	
32	014770622	3	アナトメネシ"6.35クホ"ミ	SET SCREW 6.35	
33	048080142	1	トメワシ"クヨウC8	STOP RING C8	
34	S01040001	1	サ"カ"ネ	WASHER	

M. カマ関係 / Rotary hook mechanism / Greifervorrichtung /
 Mécanisme du crochet rotatif / Mecanismo del cangrejo

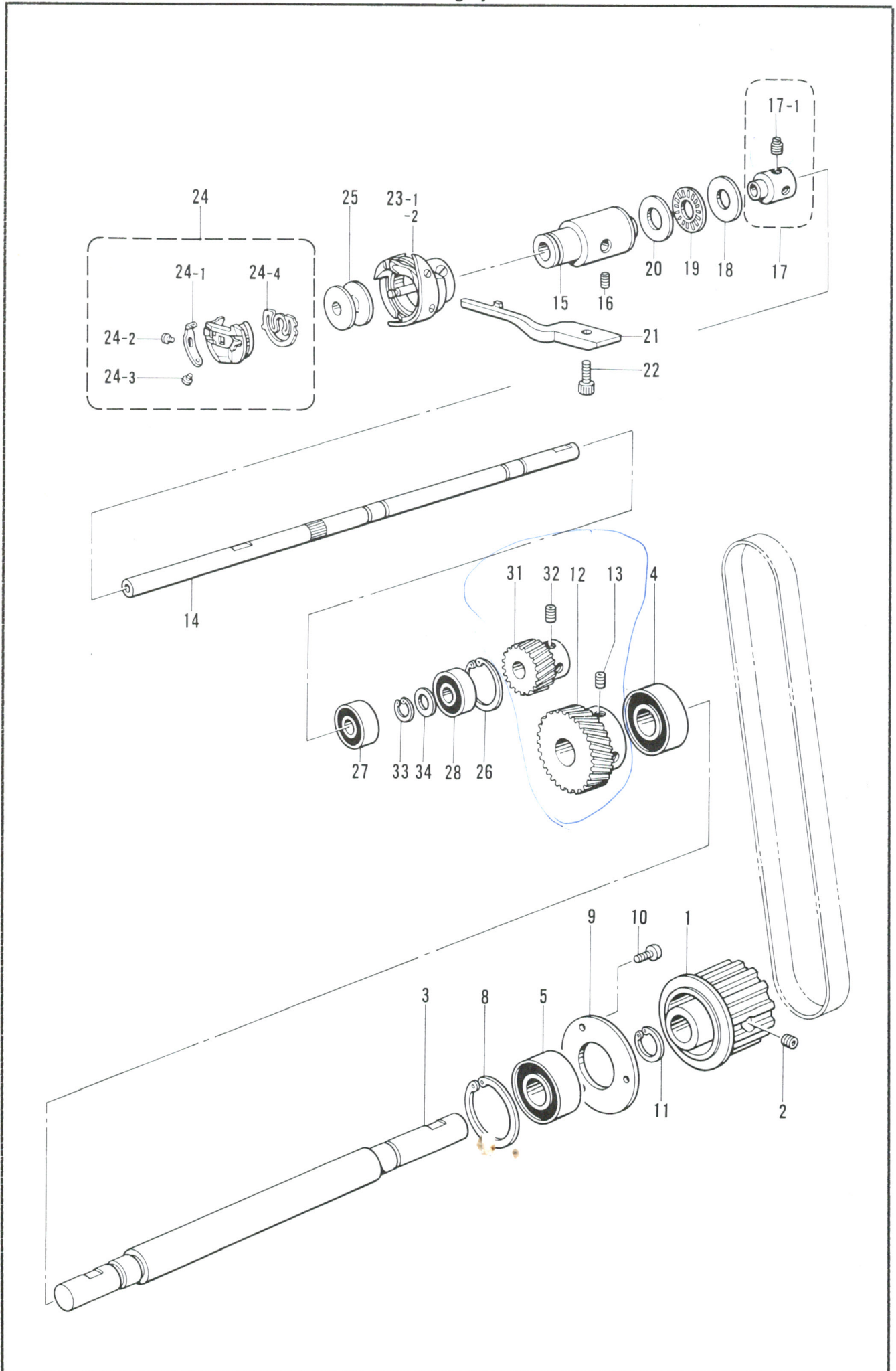

L. 折り曲げ土台関係/Folding margin base mechanism/Faltungsvorrichtungsgundplatte/
 Mécanisme de base de marge d'ourlet/Mecanismo base de margen de plegado

REF.NO.	CODE	Q'TY	ヒンメイ	NAME OF PARTS	RMKS
45	018501222	2	アナボルト5X12	BOLT 5X12	
46	028050242	2	ハネサカネ2-5	SPRING WASHER 2-5	
47	S11880000	1	スイッチトリツケカナク"20	SWITCH SET METAL FITTING 20	
48	S12151009	1	ケーシ"ササエ	CENTER BLADE SUPPORT	
49	S12152001	2	ケーシ"ササエシ"クA	CENTER BLADE SUPPORT SHAFT (A)	
50	S12153001	2	ケーシ"ササエシ"クB	CENTER BLADE SUPPORT SHAFT (B)	
51	018400822	4	アナボルト4X8	BOLT 4X8	
52	028040242	4	ハネサカネ2-4	SPRING WASHER 2-4	
53	S12154000	4	ガイドホイール	GUIDE WHEEL	
54	028040242	4	ハネサカネ2-4	SPRING WASHER 2-4	
55	021400103	4	ナット1"ユ4	NUT 4	
56	S12051000	2	ロックシリンダー"ク三A	LOCK CYLINDER ASSEMBLY (A)	
56-1	S12052000	2	ロックシリンダー"	LOCK CYLINDER	
56-2	S11433000	4	ホースニツプル4M5	HOSE NIPPLE 4M5	
57	S12053000	8	CQ2ボルトM3X25	CQ2 BOLT M3X25	
58	028030243	8	ハネサカネ2-3	SPRING WASHER 2-3	
59	525664000	1	コードホルダ"6N	CORD HOLDER (6N)	
60	062400806	5	ナヘ"コ4X8	SCREW M4X8	
61	025040233	5	ヒラサ"カ"ネチユウ4	PLAIN WASHER 4	
62	117934009	1	メクラセン	OIL CAP	
63	018062022	2	アナボルト6X20	BOLT 6X20	
64	028060242	2	ハネサカネ2-6	SPRING WASHER 2-6	
65	018062522	2	アナボルト6X25	BOLT 6X25	
66	028060242	2	ハネサカネ2-6	SPRING WASHER 2-6	
67	025060232	2	ヒラサ"カ"ネチユウ6	PLAIN WASHER 6	
71	S15526001	2	アシ"ヤストネジ"	ADJUST SCREW	
72	S15525001	2	チヨウセイシ"ク	ADJUST SHAFT	
73	014060632	2	アナトメ6X6クボ"ミ	SET SCREW 6X6	
74	018062022	2	アナボルト6X20	BOLT 6X20	
75	025060232	2	ヒラサ"カ"ネチユウ6	PLAIN WASHER 6	
76	028060242	2	ハネサカネ2-6	SPRING WASHER 2-6	
77	S00480000	4	コードホルダ"5N	CORD HOLDER (5N)	

L. 折り曲ゲ土台関係 / Folding margin base mechanism / Faltungsvorrichtunggrundplatte / Mécanisme de base de marge d'ourlet / Mecanismo base de margen de plgado

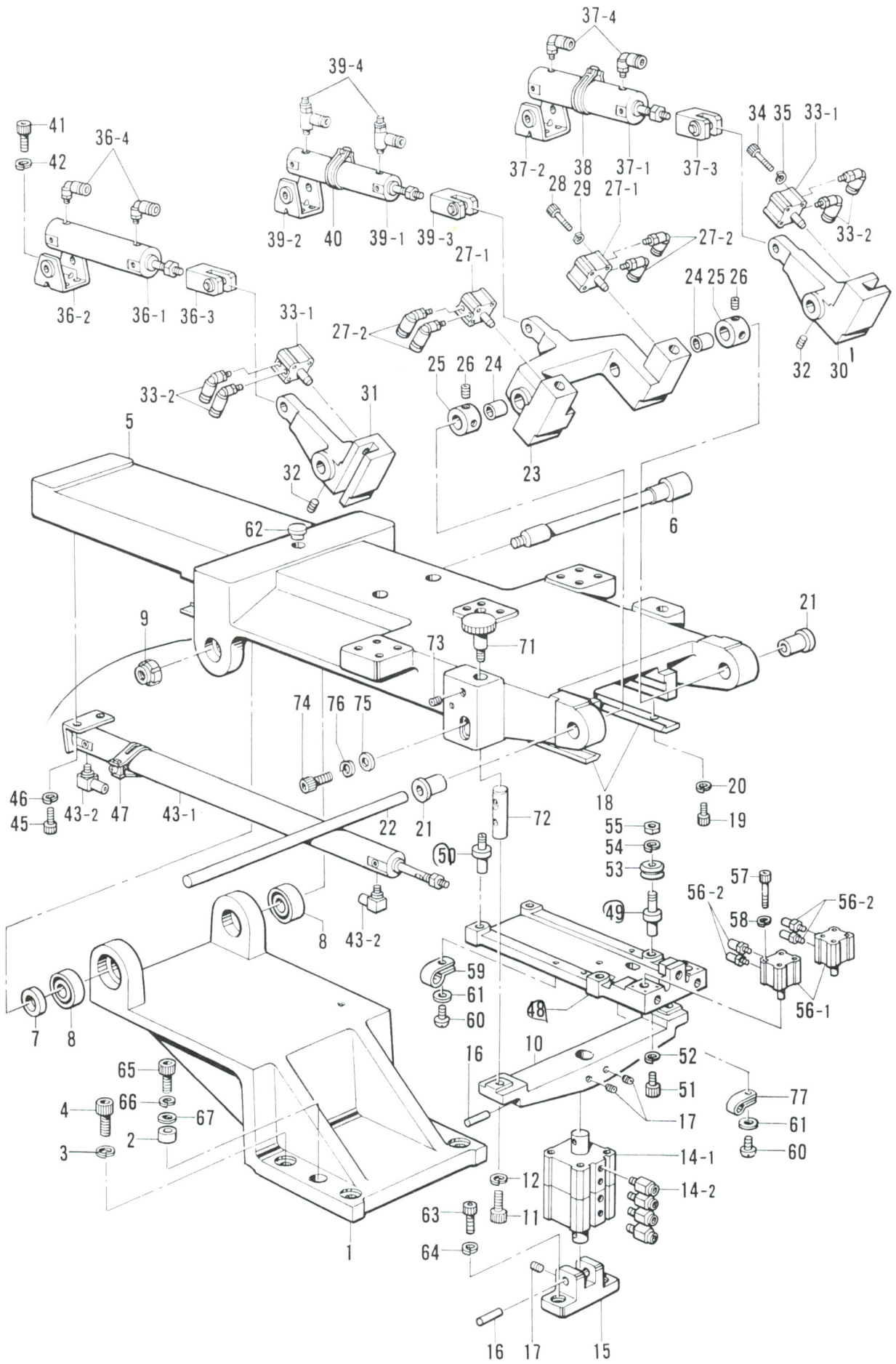

L. 折り曲げ土台関係 / Folding margin base mechanism / Faltungsvorrichtungsgundplatte /
 Mécanisme de base de marge d'ourlet / Mecanismo base de margen de plegado

REF.NO.	CODE	Q'TY	ヒンメイ	NAME OF PARTS	RMKS
1	S15532009	1	ヒンジ"ト"タ"イ	HINGE BASE	
2	S12119001	2	ピン	PIN	
3	028080242	4	ハ"ネサ"カ"ネ2-8	SPRING WASHER 2-8	
4	018082522	4	アナホ"ルト8X25	BOLT 8X25	
5	S15556009	1	オリト"タ"イ	FOLDING BASE	
6	S15530001	1	オリト"タ"イシ"ク	FOLDING BASE SHAFT	
7	S15531001	1	オリト"タ"イカラ-	FOLDING BASE COLLAR	
8	S12123000	2	アンキ"ユラタマシ"クウケ2	ANGULAR BALL BEARING 2	
9	S04782000	1	フライン"U"ナツトSS-AN02	FAIN (U) NUT SS-AN02	
10	S15542109	1	オリト"タ"イヒンシ"ウエ	FOLDING BASE HINGE UPPER	
11	018081622	2	アナホ"ルト8X16	BOLT 8X16	
12	028080242	2	ハ"ネサ"カ"ネ2-8	SPRING WASHER 2-8	
14	S12125000	1	ウスカ"タシリンダ"-ABクミ	THIN TYPE CYLINDER (AB) ASSEMBLY	
14-1	S12126000	1	ウスカ"タシリンダ"-AB	THIN TYPE CYLINDER (AB)	
14-2	S04910000	4	ハ-フユニオン	HALF UNION	
15	S12127109	1	オリト"タ"イヒンシ"	FOLDING BASE HINGE	
16	S12128101	2	オリト"タ"イヒンシ"シ"ク	FOLDING BASE HINGE SHAFT	
17	014500522	4	アナトメネシ"5クホ"ミ	SET SCREW 5	
18	S12129000	2	トラツクレール	TRACK RAIL	
19	018400832	20	アナホ"ルト4X8	BOLT 4X8	
20	028040242	20	ハ"ネサ"カ"ネ2-4	SPRING WASHER 2-4	
21	S12130000	2	フランシ"フ"ツシユ1520	FLANGE BUSH 1520	
22	S12131000	1	LMシャフト15	LM SHAFT 15	
23	S12132009	1	ナカオサエレハ-	INNER CLAMP LEVER	
24	S12133000	2	フ"ツシユ1512	BUSH 1512	
25	S12134001	2	ナカオサエカラ-	INNER CLAMP COLLAR	
26	014060632	4	アナトメ6X6クホ"ミ	SET SCREW 6X6	
27	S12135000	2	ロツクシリンダ"-クミB	LOCK CYLINDER ASSEMBLY (B)	
27-1	S12052000	2	ロツクシリンダ"-	LOCK CYLINDER	
27-2	S11426000	4	エルホ"ユニオン4M5	ELBOW UNION 4M5	
28	S12053000	8	CQ2ホ"ルトM3X25	CQ2 BOLT M3X25	
29	028030243	8	ハ"ネサ"カ"ネ2-3	SPRING WASHER 2-3	
30	S12136009	1	ア-ムR	ARM (R)	
31	S12137009	1	ア-ムL	ARM (L)	
32	014060632	2	アナトメ6X6クホ"ミ	SET SCREW 6X6	
33	S12135000	2	ロツクシリンダ"-クミB	LOCK CYLINDER ASSEMBLY (B)	
33-1	S12052000	2	ロツクシリンダ"-	LOCK CYLINDER	
33-2	S11426000	4	エルホ"ユニオン4M5	ELBOW UNION 4M5	
34	S12053000	8	CQ2ホ"ルトM3X25	CQ2 BOLT M3X25	
35	028030243	8	ハ"ネサ"カ"ネ2-3	SPRING WASHER 2-3	
36	S12138000	1	シリンダ"-25X50クミ	CYLINDER 25X50 ASSEMBLY	
36-1	S12140000	1	シリンダ"-25X50	CYLINDER 25X50	
36-2	S12139000	1	ヨウト"ウウケカナク"1	ROCK SUPPORT METAL FITTING 1	
36-3	S11994000	1	2ヤマナツクルシ"ヨイント1	KNUCKLE JOINT 1	
36-4	S11426000	2	エルホ"ユニオン4M5	ELBOW UNION 4M5	
37	S12141000	1	シリンダ"-25X50Sクミ	CYLINDER 25X50 (S) ASSEMBLY	
37-1	S12142000	1	シリンダ"-25X50S	CYLINDER 25X50 (S)	
37-2	S12139000	1	ヨウト"ウウケカナク"1	ROCK SUPPORT METAL FITTING 1	
37-3	S11994000	1	2ヤマナツクルシ"ヨイント1	KNUCKLE JOINT 1	
37-4	S11426000	2	エルホ"ユニオン4M5	ELBOW UNION 4M5	
38	S12271000	1	スイッチトリツケカナク"25	SWITCH SET METAL FITTING 25	
39	S12144100	1	シリンダ"-20X50クミ	CYLINDER 20X50 ASSEMBLY	
39-1	S12146000	1	シリンダ"-20X50	CYLINDER 20X50	
39-2	S12145000	1	ヨウト"ウウケカナク"2	ROCK SUPPORT METAL FITTING 2	
39-3	S11988000	1	2ヤマナツクルシ"ヨイント2	KNUCKLE JOINT 2	
39-4	S15567000	2	スピ"コン(OUT)	SPEED CONTROLLER (OUT)	
40	S11880000	1	スイッチトリツケカナク"20	SWITCH SET METAL FITTING 20	
41	018501222	12	アナホ"ルト5X12	BOLT 5X12	
42	028050242	12	ハ"ネサ"カ"ネ2-5	SPRING WASHER 2-5	
43	S23396000	1	シリンダ"-20X335クミ	CYLINDER 20X335 ASSEMBLY	
43-1	S23397000	1	シリンダ"-20X335	CYLINDER 20X335	
43-2	S12150000	2	ホ-スエルホ"M-5HL-4	TUBE ELBOW (M-5HL-4)	

L. 折り曲ゲ土台関係 / Folding margin base mechanism / Faltungsvorrichtunggrundplatte /
 Mécanisme de base de marge d'ourlet / Mecanismo base de margen de plegado

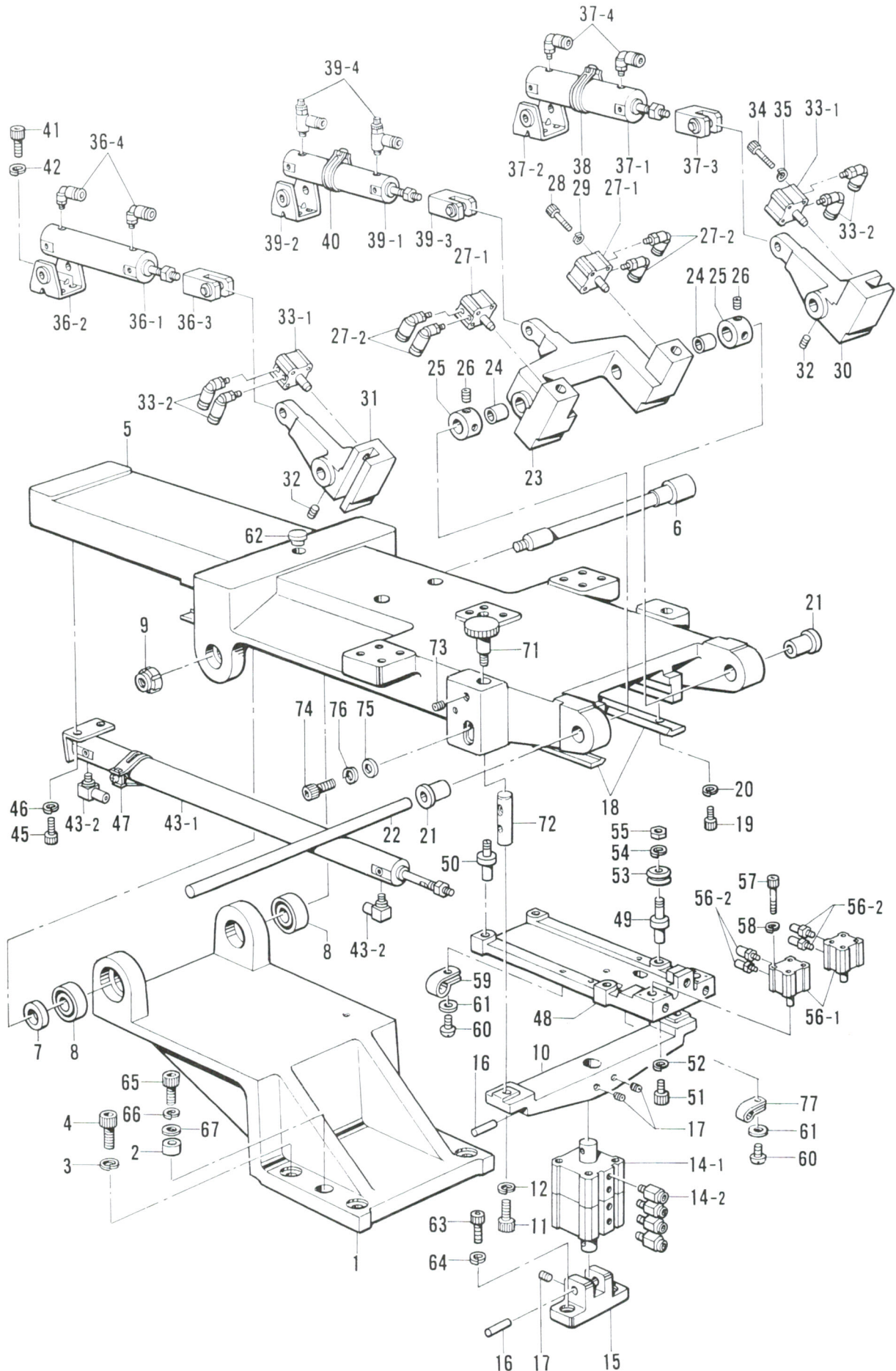

K. 折り曲げ関係/Folding margin mechanism/Faltungsvorrichtung/
 Mécanisme de marge d'ourlet/Mecanismo de margen de plegado

REF.NO.	CODE	Q'TY	ヒンメイ	NAME OF PARTS	RMKS
11	S24889001	1	コネクタブ"ロツクLクミ	CONNECT BLOCK (L) ASSEMBLY	
11-1	S24458001	1	コネクタブ"ロツクL-1	CONNECT BLOCK (L-1)	
11-2	S24459001	1	コネクタブ"ロツクL-2	CONNECT BLOCK (L-2)	
11-3	018502022	2	アナボルト5X20	BOLT 5X20	
11-4	028050242	2	ハ"ネサ"カ"ネ2-5	SPRING WASHER 2-5	
14	S21121001	1	コネクタブ"ロツクSSR	CONNECT BLOCK (SSR)	
15	S21122001	1	コネクタブ"ロツクSSL	CONNECT BLOCK (SSL)	
16	S21123001	2	コネクタブ"ロツクS	CONNECT BLOCK (S)	
17	S24828000	1	クランプ"リンク"12	CLAMP RING 12	
18	S24890001	1	イチキ"メイタ(ラベルソウチ)	POSITIONING PLATE (LABEL DEVICE)	
19	062400616	2	ナヘ"コM4X6	SCREW 4X6	
20	028040243	2	ハ"ネサ"カ"ネ2-4	SPRING WASHER 2-4	
21	025040233	2	ヒラサ"カ"ネチユウ4	PLAIN WASHER 4	
22	S24893000	1	オリイタウエJ	FOLDING PLATE UPPER (J)	

K. 折り曲げ関係/Folding margin mechanism/Faltungsvorrichtung/
 Mécanisme de marge d'ourlet/Mecanismo de margen de plegado

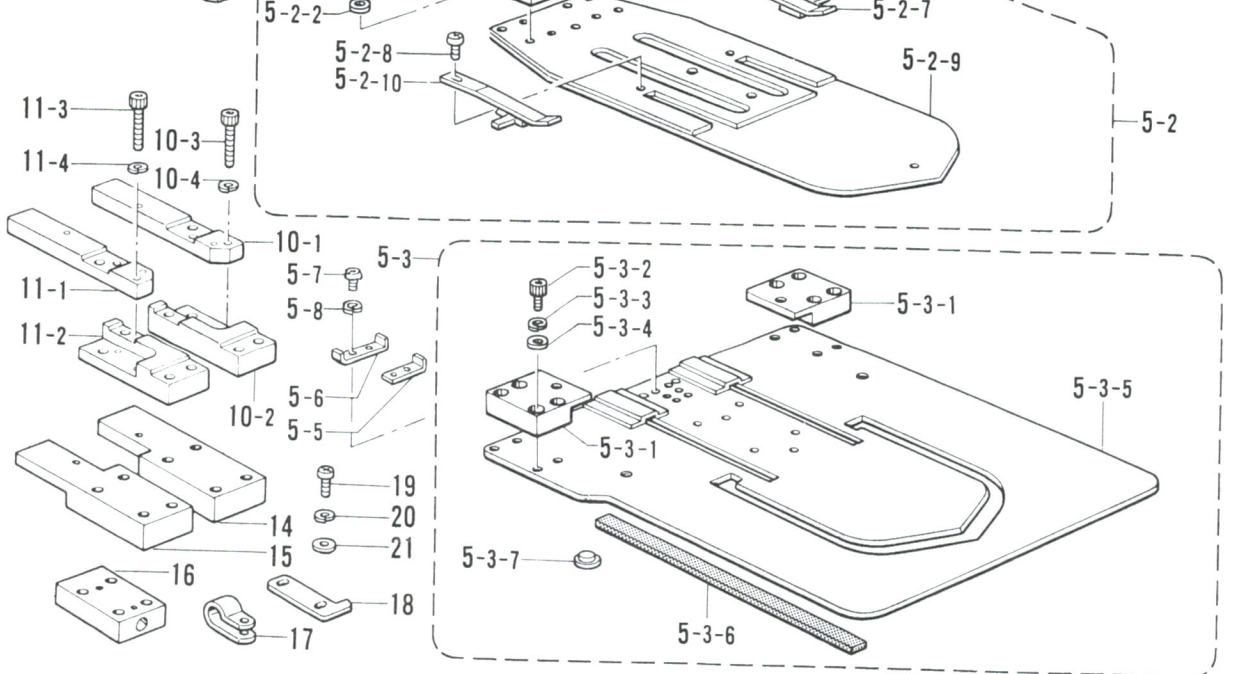
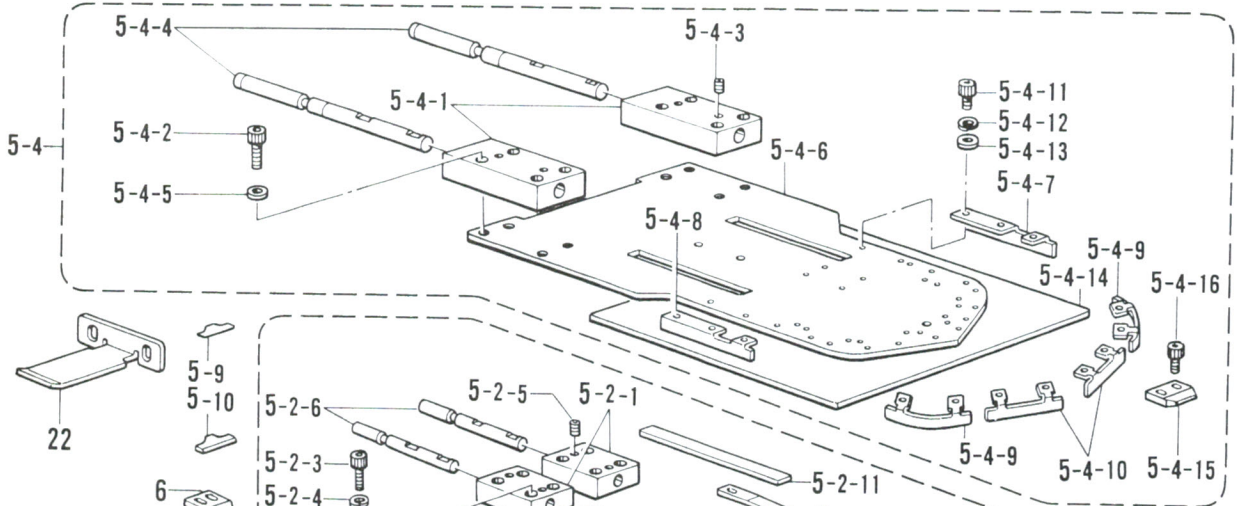
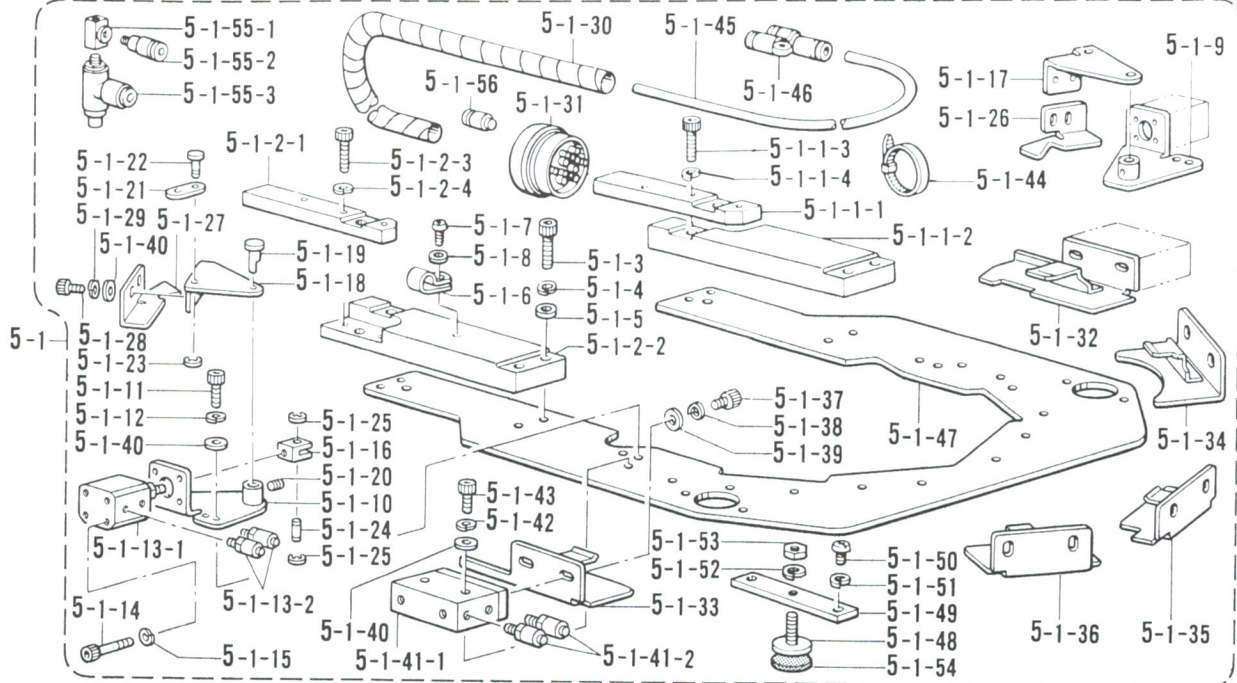

K. 折り曲げ関係 / Folding margin mechanism / Faltungsvorrichtung /
Mécanisme de marge d'ourlet / Mecanismo de margen de plegado

REF.NO.	CODE	Q'TY	ヒンメイ	NAME OF PARTS	RMKS
5-1-49	S12294001	2	トリツケイタ(オリササエ)	FITTING PLATE (FOLDING CLAMP)	
5-1-50	062401006	4	ナヘ"コ4X10	SCREW 4X10	
5-1-51	028040243	4	ハ"ネサ"カ"ネ2-4	SPRING WASHER 2-4	
5-1-52	028060243	2	ハ"ネサ"カ"ネ2-6	SPRING WASHER 2-6	
5-1-53	021060206	2	2シユナツト6	NUT 6	
5-1-54	S12297000	2	スホ"ンシ"2-30	SPONGE 2-30	
5-1-55	S15564000	1	チ-M5クミ	T-M5 ASSEMBLY	
5-1-55-1	S15563000	1	チ-M5	T-M5	
5-1-55-2	S04905000	1	ハーフユニオン	HALF UNION	
5-1-55-3	S14328000	2	シホ"リハ"ン	THROTTLE VALVE	
5-1-56	S19555000	2	キャツプ4	CAP 4	
5-2	S24875---	1	ケ"ーシ"クミ-マル2J	CENTER BLADE ASSEMBLY (ROUND-2J)	
5-2-1	S12107001	2	コネクトフ"ロツク(GAGE)	CONNECT BLOCK (CENTER BLADE)(GAGE)	
5-2-2	158722002	8	サ"カ"ネ4.2	WASHER 4.2	
5-2-3	018402032	8	アナホ"ルト4X20	BOLT 4X20	
5-2-4	028040242	8	ハ"ネサ"カ"ネ2-4	SPRING WASHER 2-4	
5-2-5	014500522	4	アナトメネシ"5クホ"ミ	SET SCREW 5	
5-2-6	S12108001	2	コネクトピン(ケ"ーシ")	PIN (CENTER BLADE)(GAGE)	
5-2-7	S29189---	1	イタハ"ネR0.8-マル2J	PLATE SPRING (R-0.8-ROUND-2J)	
5-2-8	060300414	4	ハ"イント"3X4	SCREW 3X4	
5-2-9	S24876---	1	ケ"ーシ"-マル2J	CENTER BLADE (ROUND-2J)	
5-2-10	S29190---	1	イタハ"ネL0.8-マル2J	PLATE SPRING (L-0.8-ROUND-2J)	
5-2-11	S24802000	2	ウケイタ(ケ"ーシ")1.6J	SUPPORT PLATE (CENTER BLADE)(GAGE-1.6J)	
5-3	S24877---	1	オサエクミ-マル2J	SEWING CLAMP ASSEMBLY (ROUND-2J)	
5-3-1	S12110001	2	コネクトフ"ロツク(オサエ)	CONNECT BLOCK (PRESSER)	
5-3-2	018401022	8	アナホ"ルト4X10	BOLT 4X10	
5-3-3	028040242	8	ハ"ネサ"カ"ネ2-4	SPRING WASHER 2-4	
5-3-4	158722002	8	サ"カ"ネ4.2	WASHER 4.2	
5-3-5	S24878---	1	オサエ-マル2J	SEWING CLAMP (ROUND-2J)	
5-3-6	S12298000	2	フォーム3X15X1000	FORM 3X15X1000	
5-3-7	S12279000	6	ウケイタ(オサエ)	SUPPORT PLATE (PRESSER)	
5-4	S24879---	1	ナカオサエクミ-マル2J	INNER CLAMP ASSEMBLY (ROUND-2J)	
5-4-1	S12113001	2	コネクトフ"ロツク(ナカ)	CONNECT BLOCK (INNER)	
5-4-2	018502522	8	アナホ"ルト5X25	BOLT 5X25	
5-4-3	014500522	4	アナトメネシ"5クホ"ミ	SET SCREW 5	
5-4-4	S12114001	2	コネクトピン(ナカ)	PIN (INNER)	
5-4-5	S20246001	8	ヒラサ"カ"ネタ"イ5	PLAIN WASHER 5	
5-4-6	S24880---	1	ナカオサエ-マル2J	INNER CLAMP (ROUND-2J)	
5-4-7	S24881---	1	ナカオサエウエ1-マル2J	INNER CLAMP UPPER-1 (ROUND-2J)	
5-4-8	S24882---	1	ナカオサエウエ2-マル2J	INNER CLAMP UPPER-2 (ROUND-2J)	
5-4-9	S24883---	2	ナカオサエウエ3-マル2J	INNER CLAMP UPPER-3 (ROUND-2J)	
5-4-10	S24884---	2	ナカオサエウエ4-マル2J	INNER CLAMP UPPER-4 (ROUND-2J)	
5-4-11	018300532	14	アナホ"ルト3X5	BOLT 3X5	
5-4-12	028030242	14	ハ"ネサ"カ"ネ2-3	SPRING WASHER 2-3	
5-4-13	025030232	14	ヒラサ"カ"ネチユウ3	PLAIN WASHER 3	
5-4-14	S12117000	1	フォーム2X200X200	FORM 2X200X200	
5-4-15	S12487000	6	オリイタウケ(ナカオサエ)	FOLDING PLATE SUPPORT (INNER CLAMP)	
5-4-16	018300532	12	アナホ"ルト3X5	BOLT 3X5	
5-5	S12111001	3	スリットC	SLIT (C)	
5-6	S12112001	3	スリットD	SLIT (D)	
5-7	062300502	6	ナヘ"コ3X5	SCREW 3X5	
5-8	028030242	6	ハ"ネサ"カ"ネ2-3	SPRING WASHER 2-3	
5-9	S16514000	2	スヘ"ーサ0.05	SPACER 0.05	
5-10	S16513000	2	スヘ"ーサ0.1	SPACER 0.1	
6	S12494000	1	オリイタウケシヨウ	FOLDING PLATE SUPPORT (SMALL)	
10	S24888001	1	コネクトフ"ロツクRクミ	CONNECT BLOCK (R) ASSEMBLY	
10-1	S24460001	1	コネクトフ"ロツクR-1	CONNECT BLOCK (R-1)	
10-2	S24461001	1	コネクトフ"ロツクR-2	CONNECT BLOCK (R-2)	
10-3	018502022	2	アナホ"ルト5X20	BOLT 5X20	
10-4	028050242	2	ハ"ネサ"カ"ネ2-5	SPRING WASHER 2-5	

A1. 動力台関係/Power table/Motorgestell/

Mécanisme du plateau de la machine/Mecanismo de la mesa de la máquina

REF.NO.	CODE	Q'TY	ヒンメイ	NAME OF PARTS	RMKS
2	S24777000	8	アシ"ヤスター20	ADJUST SCREW 20	
3	S12225000	4	キヤスター100	CASTER 420-SA-RD-100	
4	S12230001	2	キハ"ンササエA	CIRCUIT BOARD BASE PLATE (A)	
5	018400832	8	アナホ"ルト4X8	BOLT 4X8	
6	028040242	8	ハ"ネサ"カ"ネ2-4	SPRING WASHER 2-4	
7	S24774001	1	ト"ライハ"ーホ"ツクス	DRIVER BOX	
8	018400832	4	アナホ"ルト4X8	BOLT 4X8	
9	028040242	4	ハ"ネサ"カ"ネ2-4	SPRING WASHER 2-4	
10	S12235009	1	ツールホ"ツクス	TOOL BOX	
11	018400832	4	アナホ"ルト4X8	BOLT 4X8	
12	028040242	4	ハ"ネサ"カ"ネ2-4	SPRING WASHER 2-4	
13	S12236109	1	ガード"	GUARD	
14	018502222	2	アナホ"ルト5X22	BOLT 5X22	
15	028050242	2	ハ"ネサ"カ"ネ2-5	SPRING WASHER 2-5	
16	S20850001	1	フロツヒ"ーササエミキ"	FLOPPY SUPPORT (R)	
17	018400822	7	アナホ"ルト4X8	BOLT 4X8	
18	028040242	7	ハ"ネサ"カ"ネ2-4	SPRING WASHER 2-4	
19	S15533009	1	ト"タ"イL	BASE (L)	
20	018082022	7	アナホ"ルト8X20	BOLT 8X20	
21	028080242	7	ハ"ネサ"カ"ネ2-8	SPRING WASHER 2-8	
22	S12239009	1	ト"タ"イR	BASE (R)	
23	018082022	9	アナホ"ルト8X20	BOLT 8X20	
24	028080242	9	ハ"ネサ"カ"ネ2-8	SPRING WASHER 2-8	
25	S15547009	1	ハ"ネルト"タ"イ	PANEL BASE	
26	018082022	3	アナホ"ルト8X20	BOLT 8X20	
27	028080242	3	ハ"ネサ"カ"ネ2-8	SPRING WASHER 2-8	
29	S24564009	2	ハリイタ"タ"イL	NEEDLE PLATE BASE (L)	
30	018081422	6	アナホ"ルト8X14	BOLT 8X14	
31	028080242	6	ハ"ネサ"カ"ネ2-8	SPRING WASHER 2-8	
32	S12243001	1	ハリイタ"タ"イA	NEEDLE PLATE BASE (A)	
33	S23402001	1	ハ"ネルササエホ"ウ	PANEL SUPPORT STUD	
34	S12359001	1	ミゴ"ロササエ	FRONT SUPPORT	
35	062400616	1	ナヘ"コM4X6	SCREW M4X6	
36	028040243	1	ハ"ネサ"カ"ネ2-4	SPRING WASHER 2-4	
37	S12246001	1	ハ"ネルササエ	PANEL SUPPORT	
38	S12247001	1	ソウサホ"ツクスシタ	OPERATION BOX LOWER	
39	018502522	2	アナホ"ルト5X25	BOLT 5X25	
40	028050242	2	ハ"ネサ"カ"ネ2-5	SPRING WASHER 2-5	
41	S24968009	1	ホ"ケットウケLL	POCKET SUPPORT (LL)	
42	008400604	4	+トラスコ4X6	SCREW 4X6	
43	*	1	スホ"ンシ"3X170X500	SPONGE 3X170X500	
44	*	1	アテイタ	CAUL	
45	S24969009	1	ゼ"ンメンカハ"ーヒタ"リ	FRONT COVER LEFT	
46	S24970009	1	ゼ"ンメンカハ"ーミキ"	FRONT COVER RIGHT	
47	S27932009	1	ゼ"ンメンカハ"ーL	FRONT COVER (L)	
48	S15557009	1	ソクメンカハ"ーL	FRAME SIDE COVER (L)	
49	S17720009	1	ソクメンカハ"ーR	FRAME SIDE COVER (R)	
50	S24971009	1	ハイメンカハ"ー	REAR COVER	
51	008400604	59	+トラスコ4X6	SCREW 4X6	
52	*	3	+サラネジ"4X8	SCREW 4X8	
53	S24972009	1	テーブ"ルS	TABLE (S)	
54	S24973009	1	テーブ"ルL	TABLE (L)	
55	018401622	6	アナホ"ルト4X16	BOLT 4X16	
56	025040232	6	ヒラサ"カ"ネチユウ4	PLAIN WASHER 4	
57	S24974009	1	テーブ"ルカハ"ー	TABLE COVER	
58	018501222	3	アナホ"ルト5X12	BOLT 5X12	
59	028050242	3	ハ"ネサ"カ"ネ2-5	SPRING WASHER 2-5	
60	S12260009	1	ローラーササエ	ROLLER SUPPORT	
61	018082022	2	アナホ"ルト8X20	BOLT 8X20	
62	028080242	2	ハ"ネサ"カ"ネ2-8	SPRING WASHER 2-8	
63	S24975001	2	ジ"ヤハ"ラカハ"ー	BELLOW COVER	
64	S24976001	2	ジ"ヤハ"ラトリツケイタA	BELLOW SET PLATE (A)	

A1. 動力台関係 / Power table / Motorgestell /
 Mécanisme du plateau de la machine / Mecanismo de la mesa de la máquina

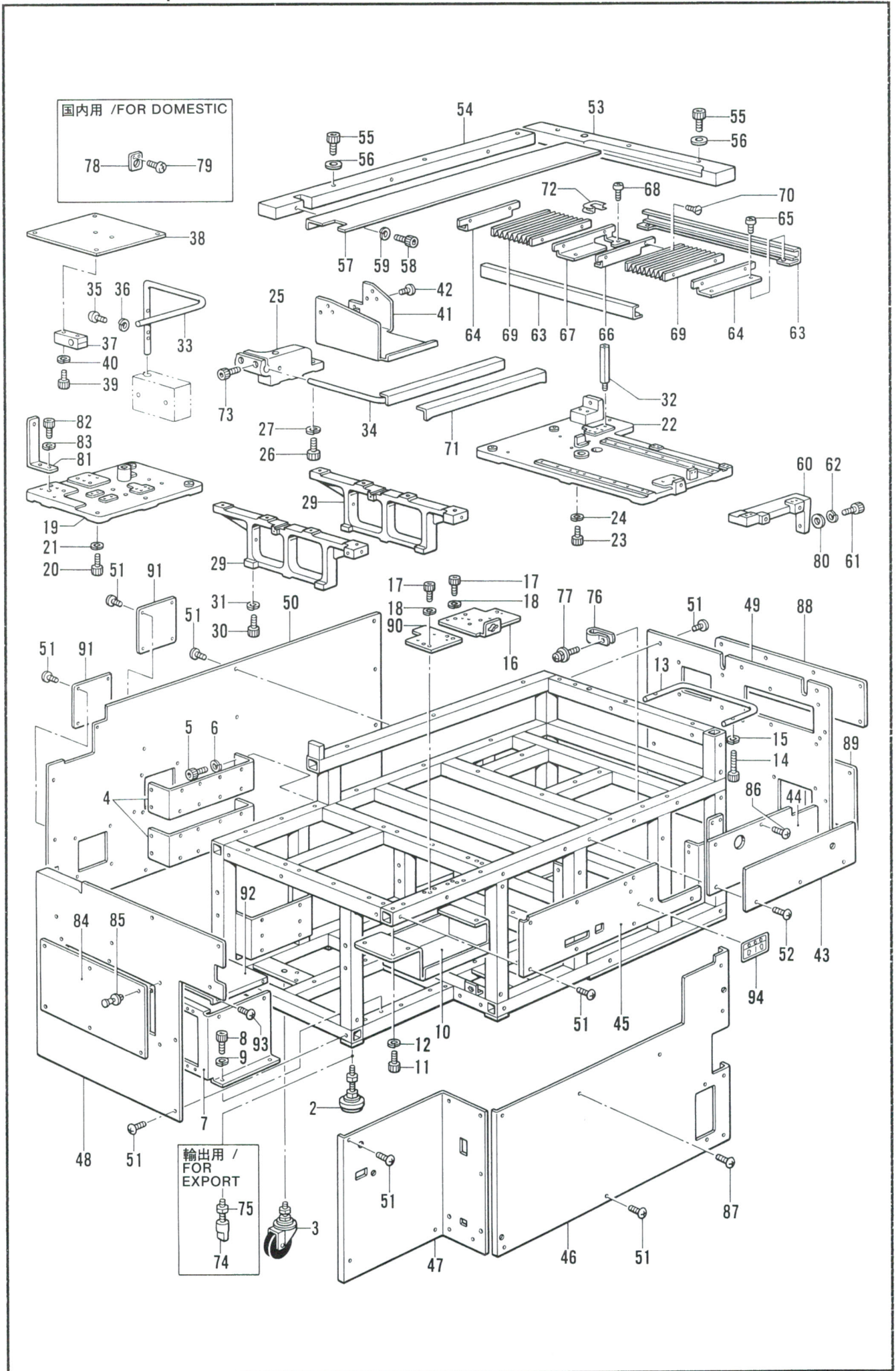

A1. 動力台関係/Power table/Motorgestell/

Mécanisme du plateau de la machine/Mecanismo de la mesa de la máquina

REF.NO.	CODE	Q'TY	ヒンメイ	NAME OF PARTS	RMKS
65	062680612	8	ナヘ"コ437-40X6	SCREW 437X6	
66	S24977001	1	ジ"ヤハ"ヲトリツケイタB	BELLOW SET PLATE (B)	
67	S24978001	1	ジ"ヤハ"ヲトリツケイタC	BELLOW SET PLATE (C)	
68	062680612	4	ナヘ"コ437-40X6	SCREW 437X6	
69	S24979001	2	ジ"ヤハ"ラクミ	BELLOW ASSEMBLY	
70	004400702	8	+サラネシ"4X7	SCREW 4X7	
71	S12280100	1	スホ"ンシ"2X440X60	SPONGE 2X44X60	
72	S12466000	1	ジ"サ"イフ"ツシユB	FREE BUSH (B)	
73	018502022	2	アナホ"ルト5X20	BOLT 5X20	
76	525907000	1	コート"ホルダ"9N	CORD HOLDER (9N)	
77	052400806	1	ナヘ"コハ"ネヒラ4X8	WASHER SCREW 4X8	
80	025080232	2	ヒラサ"カ"ネチユウ8	PLAIN WASHER 8	
81	S15528001	2	ハイメンカハ"ーササエ	REAR COVER SUPPORT	
82	018401022	4	アナホ"ルト4X10	BOLT 4X10	
83	028040242	4	ハ"ネサ"カ"ネ2-4	SPRING WASHER 2-4	
84	S15558009	1	ソクメンカハ"ーLフタ	SIDE COVER (L) CAP	
85	S12481000	26	ナイラツチ	NYLATCH	
86	*	3	+トラスコ4X8	SCREW 4X8	
87	*	1	+トラスコ4X6	SCREW 4X6	
88	S17722009	1	ソクメンカハ"ーRフタウエ	FRAME SIDE COVER (R) UPPER CAP	
89	S17721009	1	ソクメンカハ"ーRフタシタ	FRAME SIDE COVER (R) LOWER CAP	
90	S20851000	1	フロツヒ"ーササエヒタ"リ	FLOPPY SUPPORT (L)	
91	S23763009	2	ハイメンカハ"ーフタ	REAR COVER CAP	
92	S24775001	1	ト"ライハ"ーホ"ツクスウエ	DRIVER BOX UPPER	
93	008400604	4	+トラスコ4X6	SCREW 4X6	
94	S24894009	1	スタツカーシール	STACKER SEAL	
<ユシュツヨウ /FOR EXPORT>					
74	S12356001	12	-----	STAND	
75	021200203	12	-----	NUT 20	
<コクナイヨウ /FOR DOMESTIC>					
78	S12506001	1	エアガ"ンフツク	-----	
79	062680612	2	ナヘ"コ437-40X6	-----	

B1. 付属装置セット / Attachment set / Anbausatz /
 Jeu d'accessoires / Juego de fijación

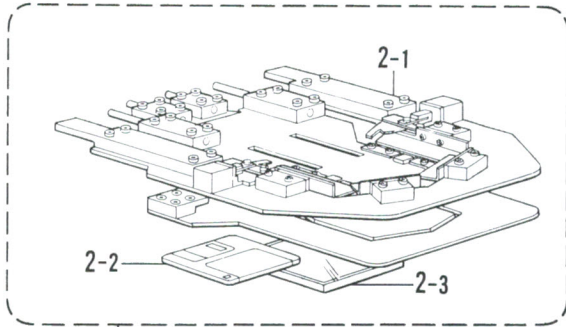

2

4

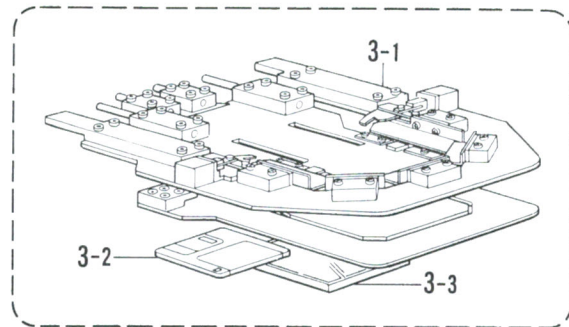

3

5

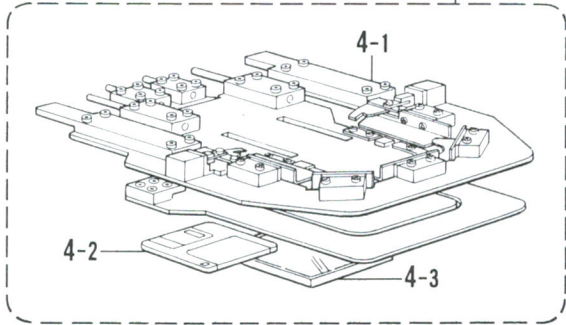

4-2

4-3

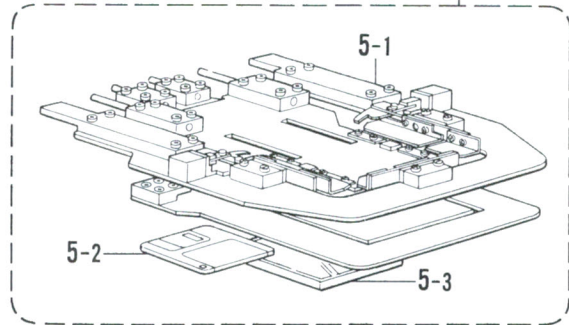

5-2

5-3

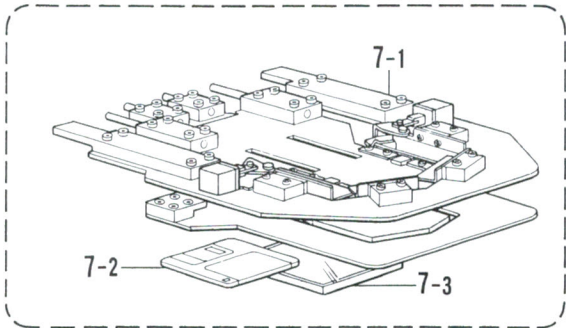

7-2

7-3

7

9

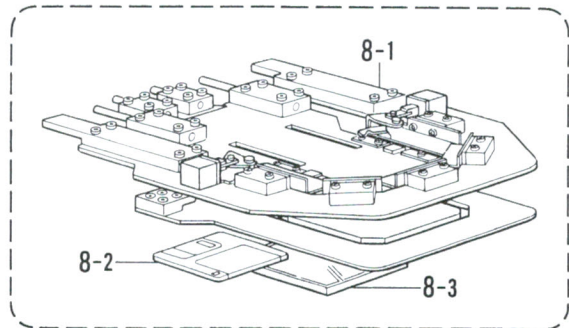

8-2

8-3

8

10

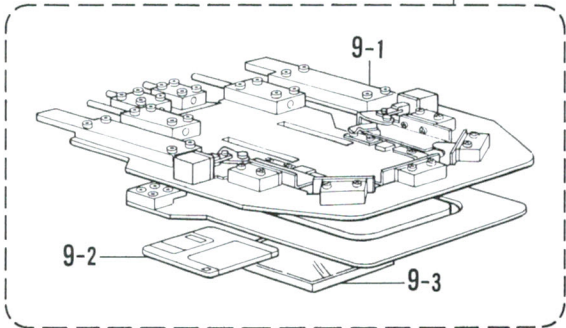

9-2

9-3

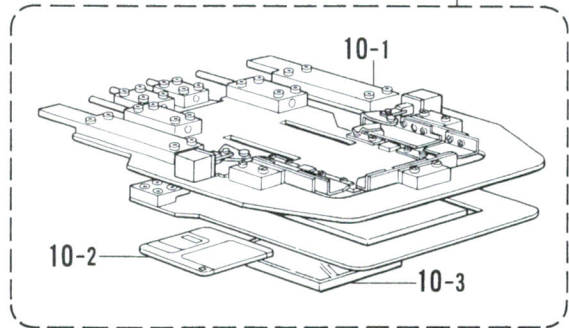

10-2

10-3

11

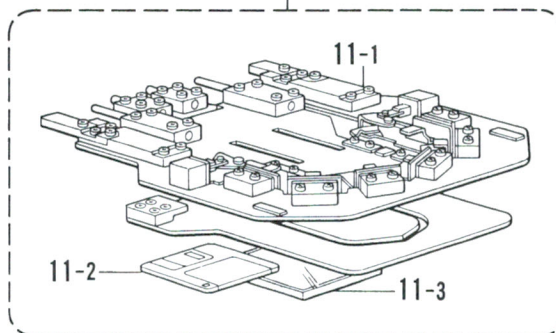

11-2

11-3

B1. 付属装置セット / Attachment set / Anbausatz /
Jeu d'accessoires / Juego de fijación

REF.NO.	CODE	Q'TY	ヒンメイ	NAME OF PARTS	RMKS
2	S12488001	1	オリキホキユウクミ-3カクL	FOLDING GROUP SUPPLY ASSEMBLY (TRIANGLE)	
2-1	S12283001	1	オリキクミ-3カク	FOLDING GROUP ASSEMBLY (TRIANGLE)	
2-2	U42775001	1	3.5メテ"イア 2DD	3.5-MEDIA 2DD	
2-3	S09989000	1	フロッピーケース	FLOPPY CASE	
3	S12489001	1	オリキホキユウクミ-5カクL	FOLDING GROUP SUPPLY ASSEMBLY (MITER-L)	
3-1	S12305001	1	オリキクミ-5カク	FOLDING GROUP ASSEMBLY (MITER)	
3-2	U42775001	1	3.5メテ"イア 2DD	3.5-MEDIA 2DD	
3-3	S09989000	1	フロッピーケース	FLOPPY CASE	
4	S12490001	1	オリキホキユウクミ-マルL	FOLDING GROUP SUPPLY ASSEMBLY (ROUND-L)	
4-1	S12323001	1	オリキクミ-マル	FOLDING GROUP ASSEMBLY (ROUND)	
4-2	U42775001	1	3.5メテ"イア 2DD	3.5-MEDIA 2DD	
4-3	S09989000	1	フロッピーケース	FLOPPY CASE	
5	S12491001	1	オリキホキユウクミ-4カクL	FOLDING GROUP SUPPLY ASSEMBLY(SQUARE-L)	
5-1	S12341001	1	オリキクミ-4カク	FOLDING GROUP ASSEMBLY (SQUARE)	
5-2	U42775001	1	3.5メテ"イア 2DD	3.5-MEDIA 2DD	
5-3	S09989000	1	フロッピーケース	FLOPPY CASE	
7	S25021001	1	オリキホキユウクミ-3カクJ	FOLDING GROUP SUPPLY ASSEMBLY(TRIANGLE-J)	
7-1	S24781001	1	オリキクミ-3カクJ	FOLDING GROUP ASSEMBLY (TRIANGLE-J)	
7-2	U42775001	1	3.5メテ"イア 2DD	3.5-MEDIA 2DD	
7-3	S09989000	1	フロッピーケース	FLOPPY CASE	
8	S25022001	1	オリキホキユウクミ-5カクJ	FOLDING GROUP SUPPLY ASSEMBLY (MITER-J)	
8-1	S24797001	1	オリキクミ-5カクJ	FOLDING GROUP ASSEMBLY (MITER-J)	
8-2	U42775001	1	3.5メテ"イア 2DD	3.5-MEDIA 2DD	
8-3	S09989000	1	フロッピーケース	FLOPPY CASE	
9	S25023001	1	オリキホキユウクミ-マル1J	FOLDING GROUP SUPPLY ASSEMBLY(ROUND-1J)	
9-1	S24808001	1	オリキクミ-マル1J	FOLDING GROUP ASSEMBLY (ROUND-1J)	
9-2	U42775001	1	3.5メテ"イア 2DD	3.5-MEDIA 2DD	
9-3	S09989000	1	フロッピーケース	FLOPPY CASE	
10	S25024001	1	オリキホキユウクミ-4カクJ	FOLDING GROUP SUPPLY ASSEMBLY(SQUARE-J)	
10-1	S24817001	1	オリキクミ-4カクJ	FOLDING GROUP ASSEMBLY (SQUARE-J)	
10-2	U42775001	1	3.5メテ"イア 2DD	3.5-MEDIA 2DD	
10-3	S09989000	1	フロッピーケース	FLOPPY CASE	
11	S24885001	1	オリキホキユウクミ-マル2J	FOLDING GROUP SUPPLY ASSEMBLY(ROUND-2J)	
11-1	S24833001	1	オリキクミ-マル2J	FOLDING GROUP ASSEMBLY (ROUND-2J)	
11-2	U42775001	1	3.5メテ"イア 2DD	3.5-MEDIA 2DD	
11-3	S09989000	1	フロッピーケース	FLOPPY CASE	

B1. 付属装置セット / Attachment set / Anbausatz /
 Jeu d'accessoires / Juego de fijación

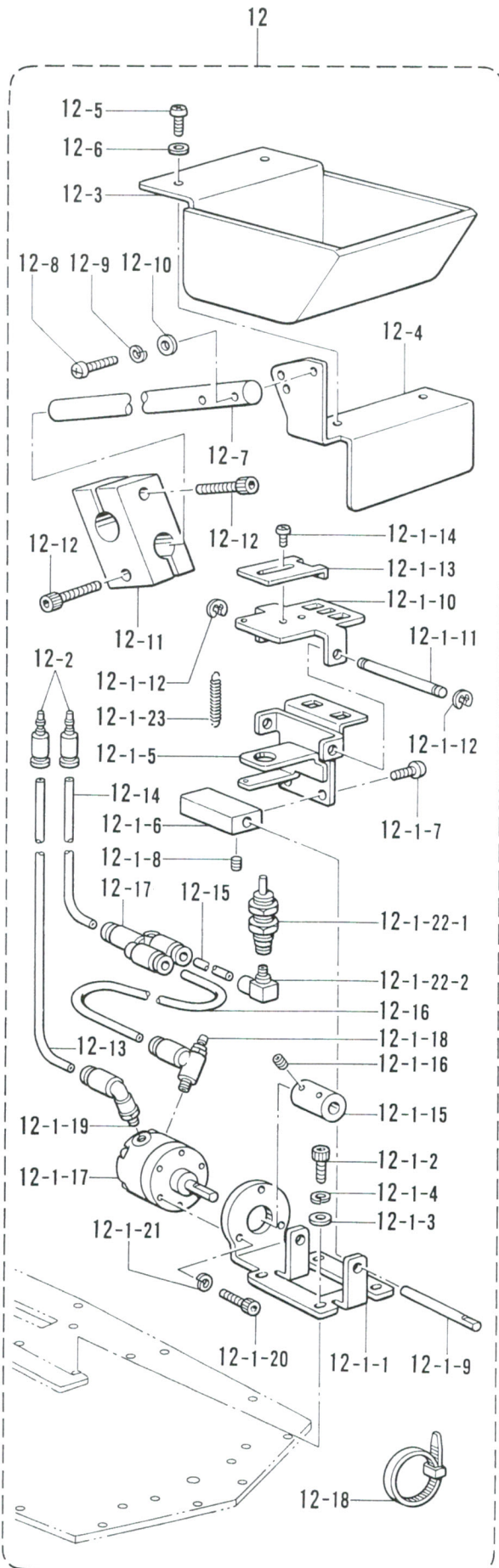
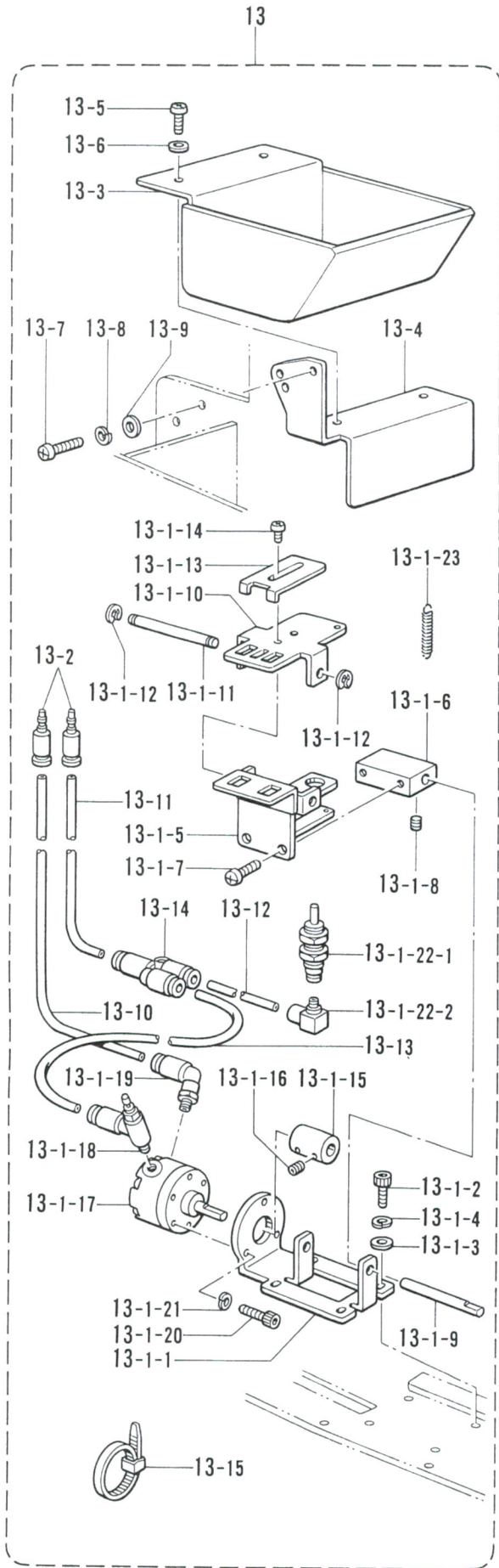

B1. 付属装置セット / Attachment set / Anbausatz /
Jeu d'accessoires / Juego de fijación

REF.NO.	CODE	Q'TY	ヒンメイ	NAME OF PARTS	RMKS
<コクナイヨウ /FOR DOMESTIC>					
<オプション /FOR OPTION>					
12	S25025001	1	ラヘルツクオオクミA	-----	
12-1	S25026001	1	ラヘルツククミ	-----	
12-1-1	S25027001	1	ササエイタ	-----	
12-1-2	018400832	2	アナホ"ルト4X8	-----	
12-1-3	025040232	2	ヒラサ"カ"ネチユウ4	-----	
12-1-4	028040242	2	ハ"ネサ"カ"ネ2-4	-----	
12-1-5	S25028001	1	ラヘル"ル"タイ	-----	
12-1-6	S25029001	1	ジ"クササエ	-----	
12-1-7	060400816	2	ハ"イント"4X8	-----	
12-1-8	014400522	2	アナクホ"ミ4X5	-----	
12-1-9	S25030001	1	ジ"ク"ホ	-----	
12-1-10	S25031001	1	ラヘル"ル"オサエ	-----	
12-1-11	S25032001	1	ジ"ク"ホA	-----	
12-1-12	048040342	2	トメフE4	-----	
12-1-13	S25033001	1	ラヘル"ル"イチキ"メ	-----	
12-1-14	060300414	2	ハ"イント"3X4	-----	
12-1-15	S25034001	1	セツトカラー	-----	
12-1-16	148294001	4	アナトメネジ"3.57クホ"ミ	-----	
12-1-17	S25036000	1	ロータリシリ"ンタ"	-----	
12-1-18	S15567000	1	スピコン(OUT)	-----	
12-1-19	S11426000	1	エルホ"ユニオン4M5	-----	
12-1-20	018301222	3	アナホ"ルト3X12	-----	
12-1-21	028030242	3	ハ"ネサ"カ"ネ2-3	-----	
12-1-22	S25037000	1	ピンシリ"ンタ"クミ	-----	
12-1-22-1	S25038000	1	ピンシリ"ンタ"	-----	
12-1-22-2	S12150000	1	ホースエルホ"M-5HL-4	-----	
12-1-23	118352001	1	ヒキハ"ネ	-----	
12-2	S25040000	2	フ"ラク"	-----	
12-3	S25044000	1	ラヘル"ル"ホ"ツクス	-----	
12-4	S25045001	1	ラヘル"ル"ホ"ツクス"スタ"イ	-----	
12-5	062400806	2	ナヘ"コ4X8	-----	
12-6	025040233	2	ヒラサ"カ"ネチユウ4	-----	
12-7	S25046001	1	ホ"ツクス"ストリ"ツクホ"ウ	-----	
12-8	062401616	2	ナヘ"コ4X16	-----	
12-9	028040243	2	ハ"ネサ"カ"ネ2-4	-----	
12-10	025040233	2	ヒラサ"カ"ネチユウ4	-----	
12-11	S24956001	1	トリ"ツクホ"ウササエ	-----	
12-12	018502022	2	アナホ"ルト5X20	-----	
12-13	S12180000	1	エア-ホース4X2.5-4	-----	
12-14	S12179000	1	エア-ホース4X2.5-3	-----	
12-15	S12178000	1	エア-ホース4X2.5-2	-----	
12-16	S25050000	1	エア-ホース4X2.5-36	-----	
12-17	S12104000	1	ユニオン"ワイ4	-----	
12-18	S04159000	1	ハ"ント"1M	-----	

B1. 付属装置セット / Attachment set / Anbausatz /
 Jeu d'accessoires / Juego de fijación

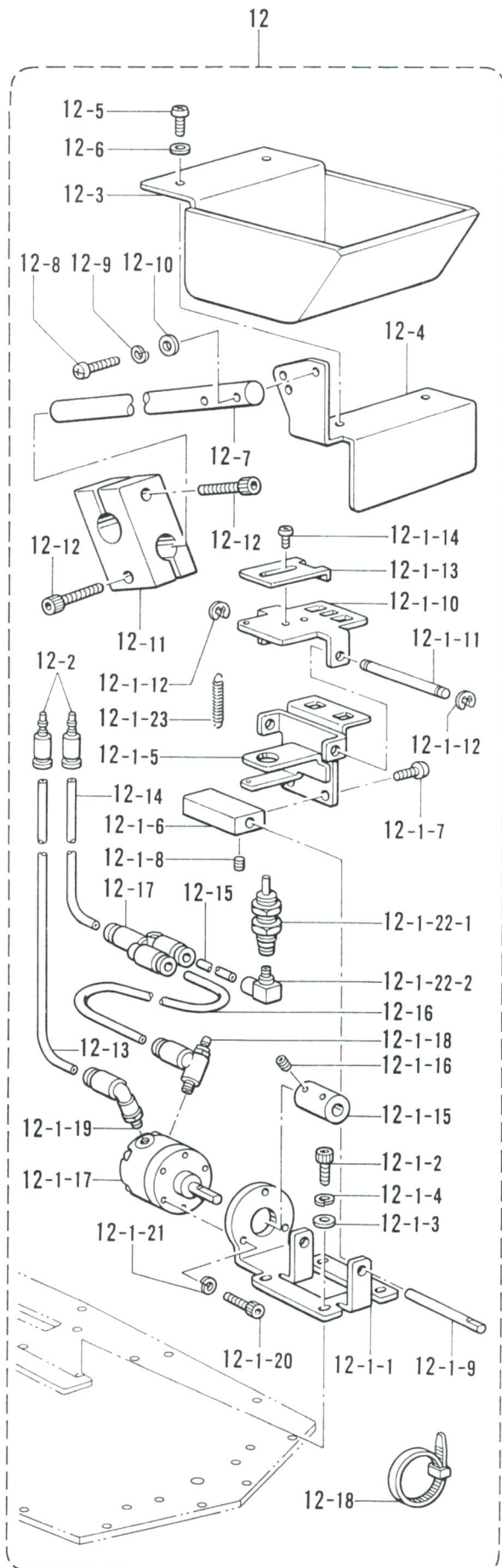
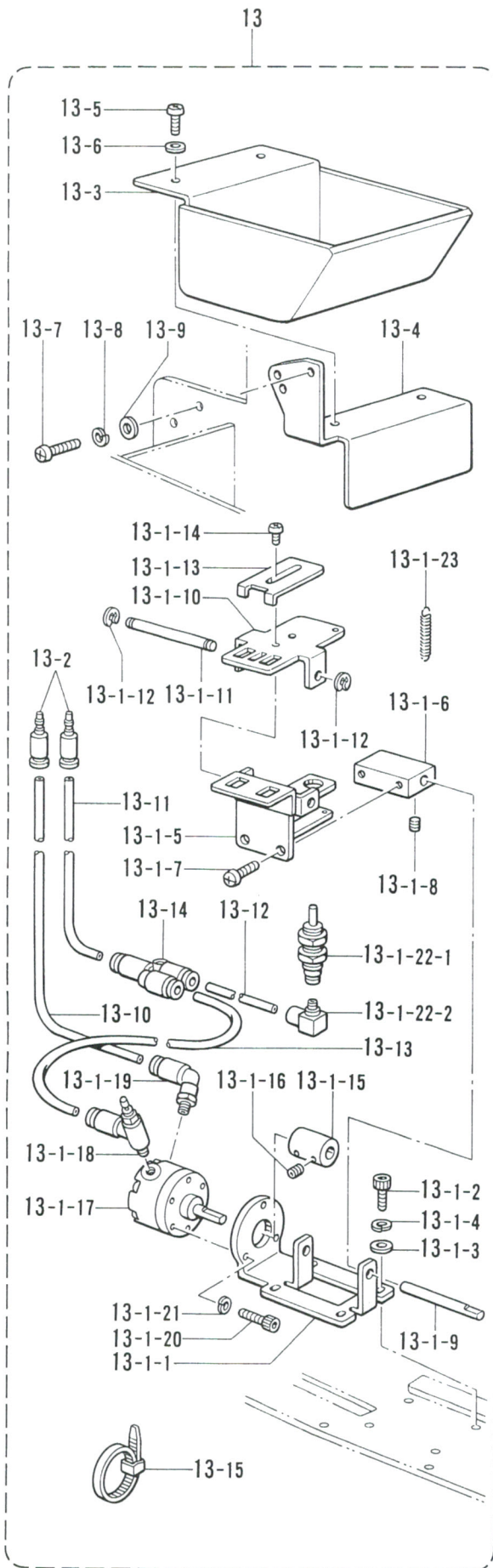

B1. 付属装置セット / Attachment set / Anbausatz /
 Jeu d'accessoires / Juego de fijación

REF.NO.	CODE	Q'TY	ヒンメイ	NAME OF PARTS	RMKS
<ユシュツヨウ /FOR EXPORT>					
<オプション /FOR OPTION>					
13	S25047001	1	-----	LABELING DEVICE(B)	
13-1	S25026001	1	-----	LABELING ASSEMBLY	
13-1-1	S25027001	1	-----	SUPPORT PLATE	
13-1-2	018400832	2	-----	BOLT 4X8	
13-1-3	025040232	2	-----	PLAIN WASHER 4	
13-1-4	028040242	2	-----	SPRING WASHER 2-4	
13-1-5	S25028001	1	-----	LABEL BRACKET	
13-1-6	S25029001	1	-----	SHAFT SUPPORT	
13-1-7	060400816	2	-----	SCREW 4X8	
13-1-8	014400522	2	-----	SET SCREW 4X5	
13-1-9	S25030001	1	-----	SHAFT (B)	
13-1-10	S25031001	1	-----	LABEL PRESSER	
13-1-11	S25032001	1	-----	SHAFT (A)	
13-1-12	048040342	2	-----	STOP RING E4	
13-1-13	S25033001	1	-----	LABEL POSITIONAL	
13-1-14	060300414	2	-----	SCREW 3X4	
13-1-15	S25034001	1	-----	SET COLLER	
13-1-16	148294001	4	-----	SET SCREW 3.57	
13-1-17	S25036000	1	-----	ROTARY CYLINDER	
13-1-18	S15567000	1	-----	SPEED CONTROLLER (OUT)	
13-1-19	S11426000	1	-----	ELBOW UNION 4M5	
13-1-20	018301222	3	-----	BOLT 3X12	
13-1-21	028030242	3	-----	SPRING WASHER 2-3	
13-1-22	S25037000	1	-----	PIN CYLINDER ASSEMBLY	
13-1-22-1	S25038000	1	-----	PIN CYLINDER	
13-1-22-2	S12150000	1	-----	TUBE ELBOW (M-5HL-4)	
13-1-23	118352001	1	-----	SPRING	
13-2	S25040000	2	-----	PLUG	
13-3	S25044000	1	-----	LABEL BOX	
13-4	S25045001	1	-----	LABEL BOX BASE	
13-5	062400806	2	-----	SCREW M4X8	
13-6	025040233	2	-----	PLAIN WASHER 4	
13-7	062401616	2	-----	SCREW 4X16	
13-8	028040243	2	-----	SPRING WASHER 2-4	
13-9	025040233	2	-----	PLAIN WASHER 4	
13-10	S12180000	1	-----	AIR TUBE 4X2.5-4 (L=260)	
13-11	S12179000	1	-----	AIR TUBE 4X2.5-3 (L=190)	
13-12	S12178000	1	-----	AIR TUBE 4X2.5-2 (L=130)	
13-13	S25050000	1	-----	AIR TUBE 4X2.5-36 (L=75)	
13-14	S12104000	1	-----	UNION-Y 4	
13-15	S04159000	1	-----	BAND 1M	

C1. 付属装置セット / Attachment set / Anbausatz /
Jeu d'accessoires / Juego de fijación

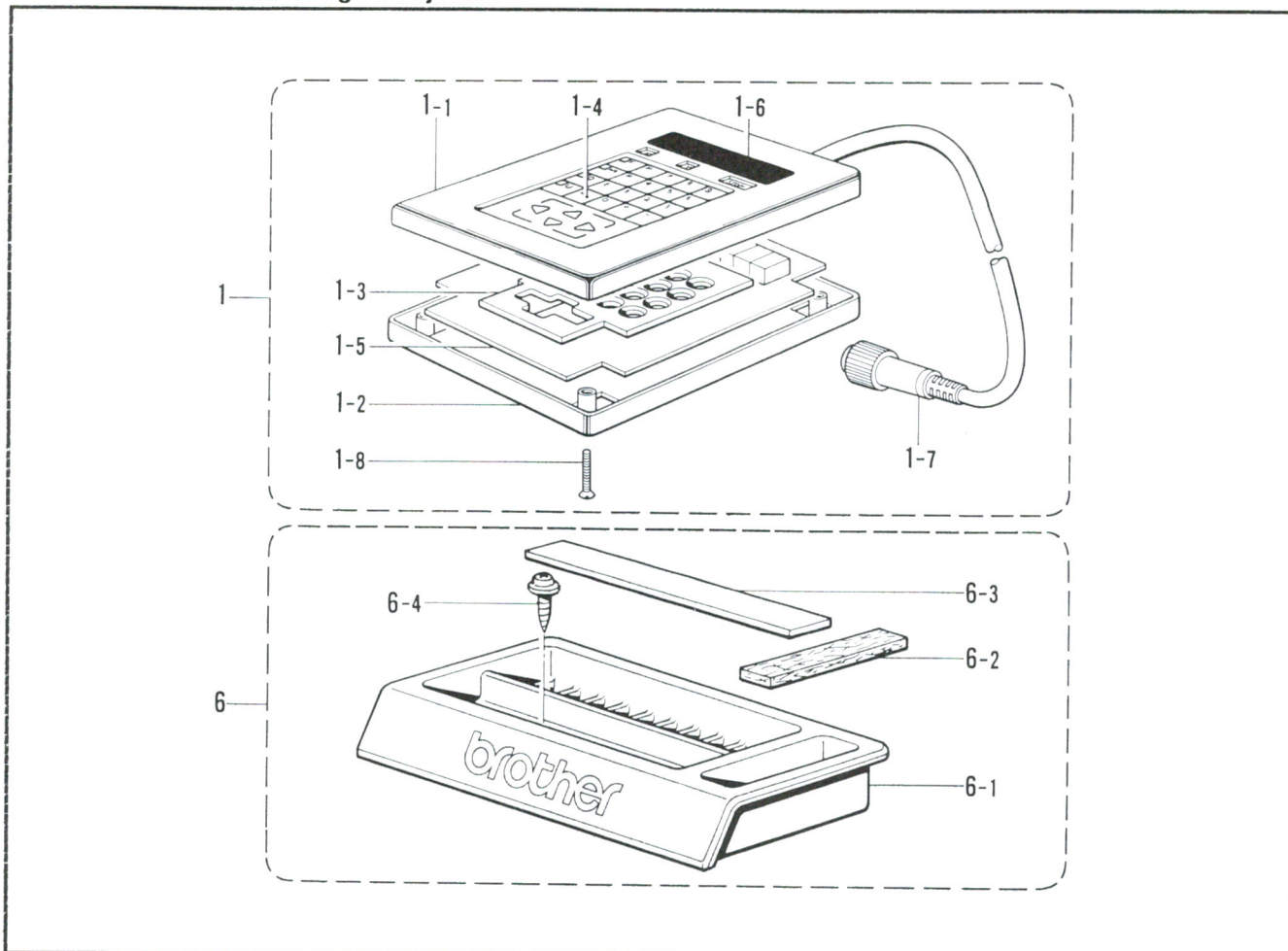

Z1. 付属品関係 / Accessories / Zubehör /
Accessoires / Accesorios

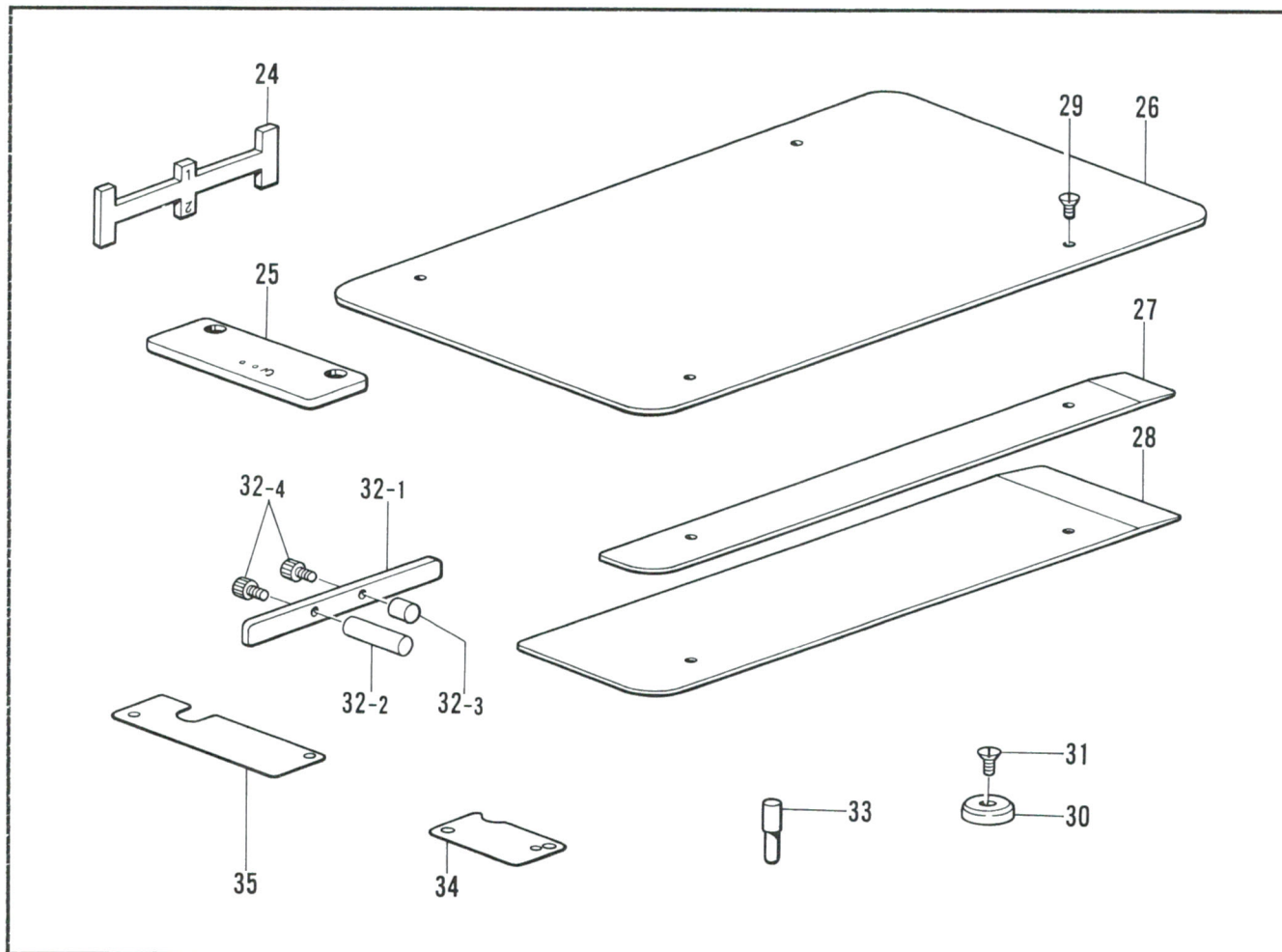

C1. 付属装置セット / Attachment set / Anbausatz /
Jeu d'accessoires / Juego de fijación

REF.NO.	CODE	Q'TY	ヒンメイ	NAME OF PARTS	RMKS
1	S02939009	1	プログラマー組み	PROGRAMMER ASSEMBLY	
1-1	S02940001	1	プログラマーハコウエ	PROGRAMMER COVER (U)	
1-2	S02941001	1	プログラマーハコシタ	PROGRAMMER COVER (D)	
1-3	S02942001	1	スペーサー	SPACER	
1-4	S02943009	1	キーボードシート	KEY BOARD SHEET	
1-5	S02947001	1	プログラマーキハバンBクミ	PROGRAMMER CIRCUIT BOARD ASSEMBLY (B)	
1-6	S02949001	1	スクリーンパネル	SCREEN PANEL	
1-7	S02950001	1	プログラマーハーネスA	PROGRAMMER HARNESS (A)	
1-8	061302506	4	サラコ3X25	SCREW 3X25	
6	183400009	1	コモノケースセット	ACCESSORY CASE SET	
6-1	S02738009	1	コモノケース	ACCESSORY CASE	
6-2	S02740000	1	フェルト	FELT	
6-3	S02739000	1	ゴムシヤクテープ	RUBBER MAGNET TAPE	
6-4	S10476001	2	ハンワツシヤタツヒンネジ	SCREW	

Z1. 付属品関係 / Accessories / Zubehör /
Accessoires / Accesorios

REF.NO.	CODE	Q'TY	ヒンメイ	NAME OF PARTS	RMKS
24	S24982000	1	テアイケージ	LOOPER TIMING GAUGE	
25	S24983000	1	ハリフリゲージ	ZIGZAG GAUGE	
26	S24984000	1	ハリイタスペーサB	NEEDLE PLATE SPACER (B)	
27	S24985000	1	ハリイタスペーサC	NEEDLE PLATE SPACER (C)	
28	S24986000	1	ハリイタスペーサD	NEEDLE PLATE SPACER (D)	
29	102843004	4	サラネジ3.57	SCREW 3.57	
30	S11857000	4	ハリイタウケ	NEEDLE PLATE SUPPORT	
31	107272002	4	サラネジ4.37	SCREW 4.37	
32	S24987001	1	ハリフリゲージイタクミ	ZIGZAG GAUGE PLATE ASSEMBLY	
32-1	S24988001	1	ハリフリゲージイタ	ZIGZAG GAUGE PLATE	
32-2	S24989001	1	ハリフリゲージシクA	ZIGZAG GAUGE SHAFT (A)	
32-3	S24990001	1	ハリフリゲージシクB	ZIGZAG GAUGE SHAFT (B)	
32-4	018401022	2	アナボルト4X10	BOLT 4X10	
33	S24773001	2	イチキメピン	POSITIONING PIN	
34	S24778000	2	ボトムスペーサA	BOTTOM SPACER (A)	
35	S24779000	2	ボトムスペーサB	BOTTOM SPACER (B)	

Z2. 付屬品關係 / Accessories / Zubehör /
Accessoires / Accesorios

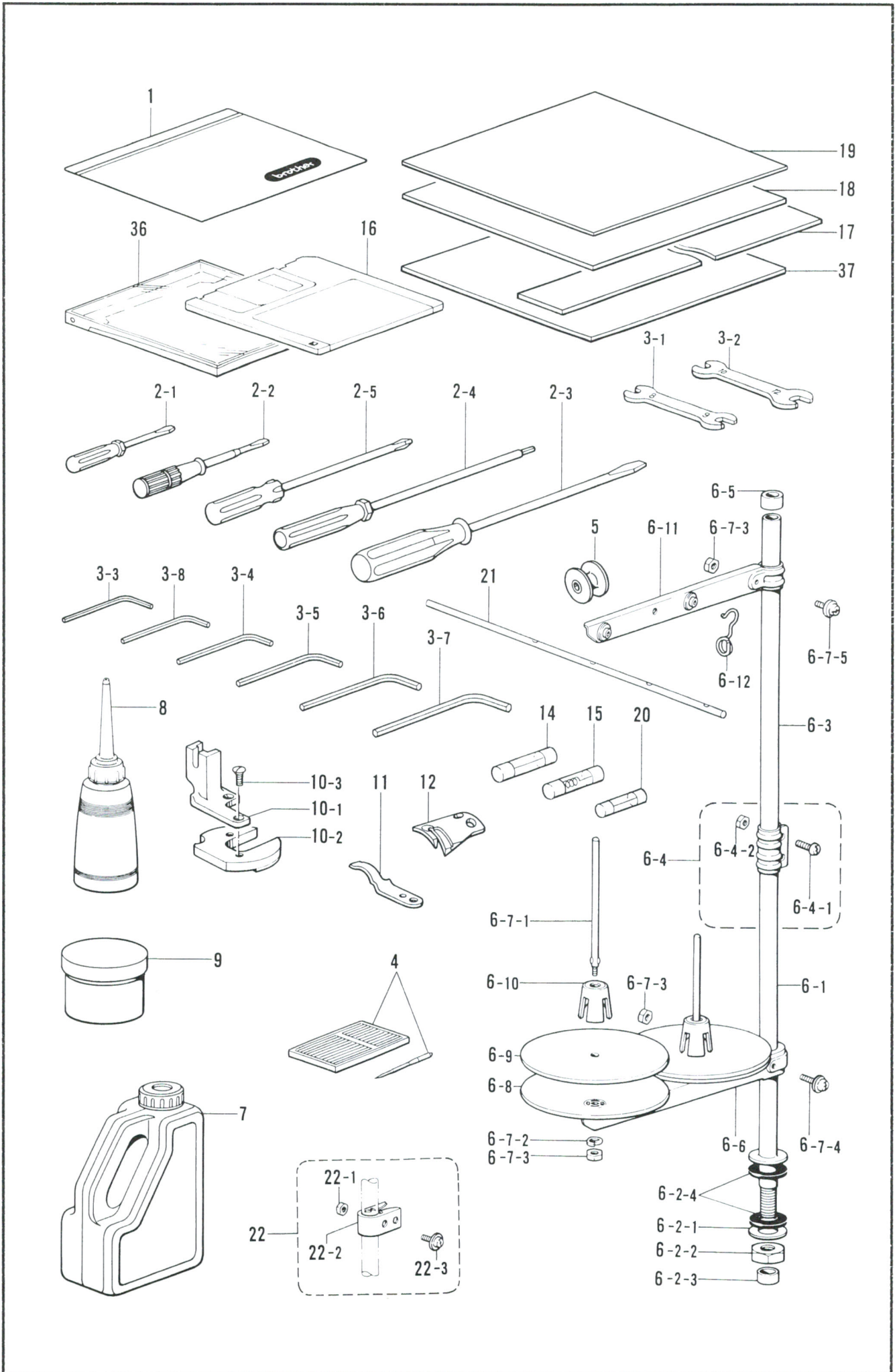

Z2. 付属品関係 / Accessories / Zubehör /
Accessoires / Accesorios

REF.NO.	CODE	Q'TY	ヒンメイ	NAME OF PARTS	RMKS
1	122991001	1	フゾクヒンホリフクロ	ACCESSORY BAG	
2-1	142443001	1	ネジマフシ1.9X52	SCREW DRIVER 1.9X52	
2-2	118837001	1	ネジマフシ3.4X70	SCREW DRIVER 3.4X70	
2-3	101572101	1	ネジマフシ5.5X190	SCREW DRIVER 5.5X190	
2-4	149173001	1	6カクホウネシマフシ3	SCREW DRIVER 3	
2-5	150332001	1	プラスチックライハ-NO.2	DRIVER NO.2	
3-1	100887001	1	スパナ8X9	SPANNER 8X9	
3-2	107780001	1	スパナ10X12	SPANNER 10X12	
3-3	146049001	1	6カクホウスパナ2	HEXAGONAL WRENCH 2	
3-4	142721001	1	6カクホウスパナ3	HEXAGONAL WRENCH 3	
3-5	118064001	1	6カクホウスパナ4	HEXAGONAL WRENCH 4	
3-6	150335001	1	6カクホウスパナ5	HEXAGONAL WRENCH 5	
3-7	115157001	1	6カクホウスパナ6	HEXAGONAL WRENCH 6	
3-8	154125001	1	6カクホウスパナ2.5	HEXAGONAL WRENCH 2.5	
4	S24705005	10	ミシンハリ1955-01	NEEDLE 1955-01	
5	S23848001	3	ホヒン1.7	BOBBIN 1.7	
6	S02763202	1	イトタテダイクミ2DR	COTTON STAND ASSEMBLY 2DR	
6-1	156112003	1	コラムパイプD	COLUMN PIPE (D)	
6-2	S02777001	1	パイプDネジセットB	PIPE (D) SCREW SET (B)	
6-2-1	150206002	1	ヒラサカネ16	PLAIN WASHER 16	
6-2-2	150191002	1	6カクナット5/8	NUT 5/8	
6-2-3	150174000	1	コラムキャップ	COLUMN CAP	
6-2-4	S01005000	2	イトタテゴム	RUBBER WASHER	
6-3	150172003	1	コラムパイプ	COLUMN PIPE	
6-4	150106003	1	コラムジョイントクミ	COLUMN JOINT ASSEMBLY	
6-4-1	062501406	2	ナヘコヒラサ5X14	SCREW 5X14	
6-4-2	021500106	2	1シユナット5	NUT 5	
6-5	150174000	1	コラムキャップ	COLUMN CAP	
6-6	S02778002	1	スプールホルダー2	SPOOL HOLDER 2	
6-7	S02780001	1	スプールネジセット2	SPOOL SCREW SET 2	
6-7-1	150179002	2	スプールシャフトB	SPOOL SHAFT (B)	
6-7-2	028050246	2	ハネサカネ2-5	SPRING WASHER 2-5	
6-7-3	021500106	4	1シユナット5	NUT 5	
6-7-4	050503006	1	ナヘコヒラサ5X30	WASHER SCREW 5X30	
6-7-5	050501406	1	ナヘコヒラサ5X14	WASHER SCREW 5X14	
6-8	150180001	2	ウケサラ	SPOOL STAND BASE	
6-9	150182000	2	スプールマット	SPOOL MAT	
6-10	126863001	2	スプールクッション	SPOOL CUSHION	
6-11	S02786002	1	スレッドハンガークミ2	THREAD HANGER ASSEMBLY 2	
6-12	S02747101	1	イトカケハネ	SPRING	
7	154702001	1	オイルタンク	OIL TANK	
8	114483002	1	ホリオリラークミ	OILER ASSEMBLY	
9	S00966000	1	グリースタンク30	GREASE TUNK 30	
10	S24742001	1	オサエアシクミ	WORK CLAMP ASSEMBLY	
10-1	S24743001	1	オサエアシ	WORK CLAMP	
10-2	S24744000	1	オサエイタ	PRESSER PLATE	
10-3	102843004	2	サラネジ3.57	SCREW 3.57	
11	159540001	1	コテイハ	FIXED KNIFE	
12	159541001	1	イトウハ	MOVABLE KNIFE	
14	S11734000	2	ヒユース20A	FUSE (20A)	
15	152565000	2	ヒユースB	FUSE (B)	
16	U42775001	2	3.5メディア2DD	3.5-MEDIA 2DD	
17	S12298000	1	フォーム3X15X1000	FORM 3X15X1000	
18	S12116000	1	スポンジ3X200X200	SPONGE 3X200X200	
19	S12117000	1	フォーム2X200X200	FORM 2X200X200	
20	S11705000	2	スローブローヒユース	SLOW BLOW FUSE	
21	S11959001	1	シタイトアンナイ	LOWER THREAD GUIDE	
22	150145009	1	イトアンナイホルダークミ	THREAD GUIDE HOLDER ASSEMBLY	
22-1	021500106	1	1シユナット5	NUT 5	
22-2	150185009	1	イトアンナイホルダー	THREAD GUIDE HOLDER	
22-3	050503006	1	ナヘコヒラサ5X30	WASHER SCREW 5X30	
36	S09989000	2	フロppyケース	FLOPPY CASE	
37	S24780000	1	フォーム3X200X200	FORM 3X200X200	

仕様別部品一覧表 / DIFFERENT PARTS LIST / ZUBEHÖRLISTE /
LISTE DES PIÉCES ACCESSOIRES / LISTA DE PIEZAS ACCESORIAS

REF.NO.	サブクラス SUB CLASS ヒンメイ PARTS	22111	32111	42111		
		200V,50-60HZ FOR DOMESTIC コクナイヨウ	200V,50-60HZ FOR DOMESTIC コクナイヨウ	200V,50-60HZ FOR DOMESTIC コクナイヨウ		
G-128	スタツカー(WORK)クミ ----- -----	-----	-----	S14461009		
S-6	ハ"ルプ"6クミ ----- -----	S24941001	-----	-----		
S-7	ハ"ルプ"12クミ ----- VALVE 12 ASSEMBLY	-----	S24942001	←		
S-57	エア-ホ-ス4X2.5-15 (L=770) ----- AIR TUBE 4X2.5-1.5 (L=770)	-----	S12191000	←		
S-94	エア-ホ-ス4X2.5-15 (L=770) ----- AIR TUBE 4X2.5-15 (L=770)	-----	S12191000	←		
S-95	エア-ホ-ス4X2.5-17 (890) ----- AIR TUBE 4X2.5-17 (L=890)	-----	S12193000	←		
S-96	エア-ホ-ス4X2.5-20 (L=1060) ----- AIR TUBE 4X2.5-20 (L=1060)	-----	S12196000	←		
S-97	エア-ホ-ス4X2.5-21 (L=1090) ----- AIR TUBE 4X2.5-21 (L=1090)	-----	S12197000	←		
A1-43	スポンジ"3X170X500 ----- SPNGE 3X170X500	S12249000	←	-----		
A1-44	アテイタ ----- CAUL	S12250009	←	-----		
A1-52	+サラネシ"4X8 ----- SCREW 4X8	004400804	←	-----		
A1-86	+トラスコ 4X8 ----- SCREW 4X8	008400806	←	-----		
A1-87	+トラスコ 4X6 ----- SCREW 4X6	008400604	←	-----		
	----- -----					
	----- -----					
	----- -----					
	----- -----					
	----- -----					

REF.NO.	サブクラス SUB CLASS ヒンメイ PARTS	31202	31203	31204		
		200V,50-60HZ FOR EXPORT ユシユツヨウ	200V,50-60HZ FOR EXPORT ユシユツヨウ	200V,50-60HZ FOR EXPORT ユシユツヨウ		
G-128	スタツカー(WORK)クミ ----- -----	-----	-----	-----		
S-6	ハ"ルブ"6クミ ----- -----	-----	-----	-----		
S-7	ハ"ルブ"12クミ ----- VALVE 12 ASSEMBLY	S24942001	←	←		
S-57	エア-ホ-ス4X2.5-15 (L=770) ----- AIR TUBE 4X2.5-1.5 (L=770)	S12191000	←	←		
S-94	エア-ホ-ス4X2.5-15 (L=770) ----- AIR TUBE 4X2.5-15 (L=770)	S12191000	←	←		
S-95	エア-ホ-ス4X2.5-17 (890) ----- AIR TUBE 4X2.5-17 (L=890)	S12193000	←	←		
S-96	エア-ホ-ス4X2.5-20 (L=1060) ----- AIR TUBE 4X2.5-20 (L=1060)	S12196000	←	←		
S-97	エア-ホ-ス4X2.5-21 (L=1090) ----- AIR TUBE 4X2.5-21 (L=1090)	S12197000	←	←		
A1-43	スポ"ンジ"3X170X500 ----- SPNGE 3X170X500	S12249000	←	-----		
A1-44	アテイタ ----- CAUL	S12250009	←	-----		
A1-52	+ サラネジ"4X8 ----- SCREW 4X8	004400804	←	-----		
A1-86	+ トラスコ 4X8 ----- SCREW 4X8	008400806	←	-----		
A1-87	+ トラスコ 4X6 ----- SCREW 4X6	008400604	←	-----		
	----- -----					
	----- -----					
	----- -----					
	----- -----					
	----- -----					

索引/INDEX/VERZEICHNIS/
INDEX/INDICE

CODE	REF.NO.	PAGE
S00337001	R - 1	76
S00470000	T - 132	88
S00480000	J - 49	28
	L - 77	62
S00909001	B - 11	4
S00910000	B - 11-1	4
S00955001	A - 14	2
	N - 17	66
S00966000	Z2 - 9	112
S01005000	Z2 - 6-2-4	112
S01040001	M - 34	64
S01201000	A - 19	2
S01304001	C - 15-2	6
S01522000	S - 1-2-6	78
	S - 1-3-7	78
	S - 18-2	78
	S - 78-1-3	84
S01542000	S - 1-2-7	78
	S - 1-3-6	78
	S - 6-6	84
	S - 7-6	78
S01824000	Y - 1-2	98
S01998001	D - 15	10
S02302001	D - 16	10
S02534101	B - 13	4
S02551001	D - 22	10
S02611001	P - 16-1	70
S02612001	P - 16-2	70
S02617001	P - 36	70
S02620001	P - 18-4	70
S02643001	R - 7	76
S02647001	R - 23	76
S02648001	R - 24	76
S02652001	R - 40	76
S02657001	F - 2	12
	R - 46	76
S02702001	N - 22	66
	N - 9	66
S02738009	C1 - 6-1	110
S02739000	C1 - 6-3	110
S02740000	C1 - 6-2	110
S02747101	Z2 - 6-12	112
S02763202	Z2 - 6	112
S02777001	Z2 - 6-2	112
S02778002	Z2 - 6-6	112
S02780001	Z2 - 6-7	112
S02786002	Z2 - 6-11	112
S02915100	T - 79	90
S02939009	C1 - 1	110
S02940001	C1 - 1-1	110
S02941001	C1 - 1-2	110
S02942001	C1 - 1-3	110
S02943009	C1 - 1-4	110
S02947001	C1 - 1-5	110
S02949001	C1 - 1-6	110
S02950001	C1 - 1-7	110
S03254001	P - 18-1	70
S04159000	B1 - 12-18	106
	B1 - 13-15	108
	G - 128-63	22
	K - 1-1-43	30
	K - 2-1-43	36
	K - 3-1-43	42
	K - 4-1-42	48
	K - 5-1-44	54
	N - 71	68
	S - 71	80

CODE	REF.NO.	PAGE
S04159000	T - 101-3	92
	T - 81	90
	W - 31	96
S04173000	T - 1-8	86
S04557000	T - 1-13	86
S04587000	H - 78	26
S04632001	P - 18-7	70
S04782000	L - 9	60
S04891000	S - 85	82
S04896000	S - 14-2	78
S04897000	S - 1-2-8	78
	S - 6-4	84
	S - 7-4	78
S04905000	G - 128-23-2	20
	K - 1-1-54-2	32
	K - 2-1-55-2	38
	K - 3-1-55-2	44
	K - 4-1-57-2	50
	K - 5-1-55-2	56
	S - 1-7	78
	S - 24-2	78
	S - 79-3-2	84
S04907000	H - 16	24
S04909000	D - 32-2	10
	G - 14-2	14
	H - 13-2	24
	S - 1-3-5	78
S04910000	L - 14-2	60
S04993000	T - 2-14	86
S05035000	T - 51-1	90
S06143000	T - 141	92
S06550001	Y - 1-1	98
S06551101	Y - 1-1-1	98
S06552000	Y - 1-1-2	98
S06857000	S - 83	82
S06858000	S - 83-1	82
S06859000	S - 83-2	82
S06999001	C - 53-1	8
S07450109	N - 26	66
S07469001	N - 25	66
S07478000	N - 53	66
S07876001	N - 24	66
S08017000	W - 18-2	96
S08106000	T - 6-2	88
S08119000	T - 41-1	90
	T - 54-1	90
S08137000	W - 30	96
S08367000	W - 18-1	96
S09027001	G - 98	16
S09141000	T - 48	86
S09142000	T - 111	88
S09197000	S - 101	80
S09231000	S - 14-1	78
S09989000	B1 - 10-3	104
	B1 - 11-3	104
	B1 - 2-3	104
	B1 - 3-3	104
	B1 - 4-3	104
	B1 - 5-3	104
	B1 - 7-3	104
	B1 - 8-3	104
	B1 - 9-3	104
	Z2 - 36	112
S10243000	J - 47	28
S10287000	T - 6-1	88
S10315000	T - 1-6	86
S10335001	T - 19	86

CODE	REF.NO.	PAGE
S10476001	C1 - 6-4	110
S11182009	P - 18-9	70
	P - 7	70
S11183009	P - 18-9-1	70
	P - 7-1	70
S11184009	P - 18-9-2	70
	P - 7-2	70
S11426000	B1- 12-1-19	106
	B1- 13-1-19	108
	C - 48-2	8
	G - 107-2	18
	G - 115-2	18
	G - 128-17-4	20
	G - 38-3	14
	G - 47-3	16
	L - 27-2	60
	L - 33-2	60
	L - 36-4	60
	L - 37-4	60
S11433000	H - 29-2	24
	K - 1-1-13-2	30
	K - 1-1-40-2	30
	K - 2-1-13-2	36
	K - 2-1-40-2	36
	K - 3-1-13-2	42
	K - 3-1-40-2	42
	K - 4-1-13-2	48
	K - 4-1-39-2	48
	K - 5-1-13-2	54
	K - 5-1-41-2	54
	L - 56-2	62
	S - 88-2	80
S11693000	T - 30	90
S11694000	T - 39	90
S11696100	T - 41	90
S11697000	T - 42	90
S11698000	T - 43	90
S11700000	T - 45	92
S11701000	T - 46	90
S11702000	T - 27	86
S11703000	T - 44	90
S11705000	Z2 - 20	112
S11706000	T - 2-21	86
S11708000	T - 104	88
S11709000	T - 102-1	88
S11711000	T - 54	90
S11712000	T - 53	90
S11715200	T - 51	90
S11716000	T - 55	86
S11717000	T - 61	86
S11728000	T - 150	88
S11730000	T - 56	90
S11731000	T - 57	90
S11732000	T - 60	90
S11734000	Z2 - 14	112
S11748000	T - 2-11	86
S11749000	T - 2-8	86
S11750000	T - 2-9	86
S11751000	T - 2-10	86
S11752000	T - 2-7	86
S11753000	T - 2-6	86
S11754000	T - 2-5	86
S11755000	T - 2-4	86
S11756100	T - 2-3	86
S11757000	T - 2-13	86
S11761000	T - 2-20	86
S11762000	T - 78	90

CODE	REF.NO.	PAGE
S11763000	T - 77	90
S11803001	T - 20	86
S11811000	T - 1-1	86
S11816000	J - 53	28
	T - 151	88
S11817000	T - 133	88
	T - 74	88
S11826000	T - 2-1	86
S11827000	T - 2-2	86
S11828000	T - 122-1	92
S11830400	T - 115-1	92
S11839000	T - 80	90
S11840000	T - 66	90
S11841000	T - 67	90
S11842000	T - 68	90
S11848000	N - 84	68
	T - 71	86
S11856001	A - 22	2
S11857000	A - 24	2
	Z1 - 30	110
S11863001	B - 7	4
S11871101	D - 11	10
S11872001	D - 12	10
S11874001	D - 25	10
S11876001	D - 28	10
S11880000	D - 33	10
	L - 40	60
	L - 47	62
S11881001	D - 34	10
S11882009	D - 36	10
S11883001	D - 20	10
S11893001	M - 9	64
S11894001	M - 12	64
S11896001	M - 15	64
S11898000	M - 18	64
S11899000	M - 19	64
S11900001	M - 31	64
S11909000	N - 56	66
S11914000	N - 60	66
S11915000	N - 46	66
S11916001	N - 45	66
S11917001	N - 54	66
S11918000	N - 52	66
S11919000	N - 57	66
S11920001	N - 61	66
S11921000	B - 2	4
	M - 4	64
S11922000	B - 3	4
	C - 3	6
S11924000	M - 28	64
S11926001	R - 13	76
S11927009	R - 37	76
S11928009	R - 37-1	76
S11929001	R - 43	76
S11930001	R - 44	76
S11936101	X - 7	98
S11937001	X - 9	98
S11945000	N - 31	66
S11946000	N - 69	68
S11947000	N - 70	68
S11949000	N - 72	68
S11952000	S - 78-1-1	84
S11953000	S - 78-1	84
S11956000	S - 78-5	84
S11957000	S - 78-6	84
S11958000	S - 78-7	84
S11959001	Z2 - 21	112

CODE	REF.NO.	PAGE
S11966001	E - 9	12
S11967001	E - 10	12
S11968009	G - 1	14
S11969000	G - 5	14
S11970009	G - 8	14
S11971009	G - 11	14
S11972001	G - 13	14
S11973000	G - 14	14
S11974000	G - 14-1	14
S11975000	G - 15	14
S11976000	G - 17	14
S11977001	G - 18	14
S11979000	G - 21	14
S11980001	G - 22	14
S11985001	G - 34	14
S11986000	G - 38	14
S11987000	G - 38-1	14
S11988000	G - 38-2	14
	L - 39-3	60
S11989009	G - 39	14
S11990001	G - 42	14
S11991001	G - 43	16
S11992000	G - 47	16
S11993000	G - 47-1	16
S11994000	G - 128-17-3	20
	G - 47-2	16
	L - 36-3	60
	L - 37-3	60
S11995009	G - 48	16
S11996000	G - 52	16
S11997001	G - 55	16
S11998009	G - 56	16
S12000009	G - 66	18
S12002000	G - 73	16
S12003000	G - 74	16
S12004000	G - 75	16
S12005001	G - 76	16
S12006000	G - 78	16
S12007000	G - 79	16
S12008000	G - 81	16
S12009000	G - 81-1	16
S12010000	G - 84	16
S12011001	G - 85	16
S12012000	G - 87	16
S12013000	G - 89	16
S12014000	G - 90	16
S12015000	G - 91	16
S12019001	G - 96	16
S12020001	G - 99	16
S12021001	G - 102	16
S12022001	G - 105	18
S12023001	G - 106	18
S12024000	G - 107	18
S12025000	G - 107-1	18
S12027109	Q - 1-1	74
S12029109	G - 112	18
S12030000	G - 115	18
S12031000	G - 115-1	18
S12033009	G - 118	18
S12035000	H - 2	24
S12036000	H - 3	24
S12038001	H - 53	24
	H - 9	24
S12039001	H - 10	24
	H - 46	24
S12043000	N - 68	68
S12044000	H - 17	24

CODE	REF.NO.	PAGE
S12045000	H - 18	24
S12050001	H - 26	24
S12051000	H - 29	24
	L - 56	62
S12052000	H - 29-1	24
	L - 27-1	60
	L - 33-1	60
	L - 56-1	62
S12053000	H - 30	24
	L - 28	60
	L - 34	60
	L - 57	62
S12054000	H - 33	24
	H - 55	24
S12056001	H - 43	24
S12060001	H - 62	26
	H - 67	26
S12062009	H - 73	26
S12063009	J - 1	28
S12065000	J - 5	28
S12066000	J - 6	28
S12067000	J - 7	28
S12068001	J - 8	28
S12069000	J - 9	28
S12070000	J - 11	28
S12074000	J - 19	28
S12075002	J - 21	28
S12076000	J - 22	28
S12077000	J - 23	28
S12078000	G - 128-7	20
	J - 24	28
S12079000	J - 25	28
S12081000	J - 27	28
S12082000	J - 32	28
S12090000	K - 1-1-13	30
	K - 2-1-13	36
	K - 3-1-13	42
	K - 4-1-13	48
	K - 5-1-13	54
S12091000	K - 1-1-13-1	30
	K - 2-1-13-1	36
	K - 3-1-13-1	42
	K - 4-1-13-1	48
	K - 5-1-13-1	54
S12092000	K - 1-1-14	30
	K - 2-1-14	36
	K - 3-1-14	42
	K - 4-1-14	48
	K - 5-1-14	54
S12093001	K - 1-1-16	30
	K - 2-1-16	36
	K - 3-1-16	42
	K - 4-1-16	48
	K - 5-1-16	54
S12096001	K - 1-1-19	30
	K - 2-1-19	36
	K - 3-1-19	42
	K - 4-1-19	48
	K - 5-1-19	54
S12097001	K - 1-1-21	30
	K - 2-1-21	36
	K - 3-1-21	42
	K - 4-1-21	48
	K - 5-1-21	54
S12098001	K - 1-1-22	30
	K - 2-1-22	36
	K - 3-1-22	42

CODE	REF.NO.	PAGE
S12098001	K - 4-1-22	48
	K - 5-1-22	54
S12099001	K - 1-1-24	30
	K - 2-1-24	36
	K - 3-1-24	42
	K - 4-1-24	48
	K - 5-1-24	54
S12103000	P - 21-1	70
	P - 9-1	70
S12104000	B1- 12-17	106
	B1- 13-14	108
	G - 128-57	22
	K - 1-1-45	30
	K - 2-1-45	36
	K - 3-1-45	42
	K - 4-1-44	48
	K - 5-1-46	54
	S - 102	80
	S - 118	82
	S - 63	80
S12106000	K - 1-1-31	30
	K - 2-1-31	36
	K - 3-1-31	42
	K - 4-1-31	48
	K - 5-1-31	54
S12107001	K - 1-2-1	32
	K - 2-2-1	38
	K - 3-2-1	44
	K - 4-2-1	50
	K - 5-2-1	56
S12108001	K - 1-2-6	32
	K - 2-2-6	38
	K - 3-2-6	44
	K - 4-2-6	50
	K - 5-2-6	56
S12110001	K - 1-3-1	32
	K - 2-3-1	38
	K - 3-3-1	44
	K - 4-3-1	50
	K - 5-3-1	56
S12111001	K - 1-5	32
	K - 2-5	38
	K - 3-5	44
	K - 4-5	50
	K - 5-5	56
S12112001	K - 1-6	32
	K - 2-6	38
	K - 3-6	44
	K - 4-6	50
	K - 5-6	56
S12113001	K - 1-4-1	32
	K - 2-4-1	38
	K - 3-4-1	44
	K - 4-4-1	50
	K - 5-4-1	56
S12114001	K - 1-4-4	32
	K - 2-4-4	38
	K - 3-4-4	44
	K - 4-4-4	50
	K - 5-4-4	56
S12116000	Z2 - 18	112
S12117000	K - 1-4-13	32
	K - 2-4-14	38
	K - 3-4-14	44
	K - 4-4-13	50
	K - 5-4-14	56
	Z2 - 19	112

CODE	REF.NO.	PAGE
S12119001	L - 2	60
S12123000	L - 8	60
S12125000	L - 14	60
S12126000	L - 14-1	60
S12127109	L - 15	60
S12128101	L - 16	60
S12129000	L - 18	60
S12130000	L - 21	60
S12131000	L - 22	60
S12132009	L - 23	60
S12133000	L - 24	60
S12134001	L - 25	60
S12135000	L - 27	60
	L - 33	60
S12136009	L - 30	60
S12137009	L - 31	60
S12138000	L - 36	60
S12139000	G - 128-17-2	20
	L - 36-2	60
	L - 37-2	60
S12140000	L - 36-1	60
S12141000	L - 37	60
S12142000	L - 37-1	60
S12144100	L - 39	60
S12145000	L - 39-2	60
S12146000	L - 39-1	60
S12150000	B1- 12-1-22-2	106
	B1- 13-1-22-2	108
	G - 81-2	16
	L - 43-2	60
	P - 21-2	70
	P - 9-2	70
	S - 88-3	80
S12151009	L - 48	62
S12152001	L - 49	62
S12153001	L - 50	62
S12154000	L - 53	62
S12155101	S - 1-1	78
S12158000	S - 1-2-2	78
S12160000	S - 1-2-3	78
	S - 6-3	84
	S - 7-2	78
S12161000	S - 1-2-4	78
	S - 1-3-2	78
	S - 6-2	84
	S - 7-3	78
S12163000	S - 6-1	84
S12164000	S - 1-3-3	78
S12165000	S - 1-6	78
S12166000	S - 14	78
S12167000	S - 24	78
S12168000	S - 18	78
S12169000	S - 18-1	78
S12170000	S - 18-3	78
S12171001	S - 19	78
S12172000	S - 20	78
S12173000	S - 24-1	78
S12174000	S - 24-3	78
S12175000	S - 29	78
S12176000	S - 32	78
S12178000	B1- 12-15	106
	B1- 13-12	108
	S - 117	82
	S - 36	80
S12179000	B1- 12-14	106
	B1- 13-11	108
	S - 37	80

CODE	REF.NO.	PAGE
S12180000	B1 - 12-13	106
	B1 - 13-10	108
S12181000	S - 39	80
S12182000	S - 40	80
S12183000	G - 128-56	22
	S - 41	80
S12184000	S - 42	80
S12185000	S - 43	80
S12186000	S - 44	80
S12187000	S - 45	80
S12188000	S - 46	80
S12189000	S - 47	80
S12190000	S - 48	80
S12191000	S - 49	80
	S - 57	80
	S - 79-20	84
	S - 94	80
S12192000	S - 50	80
S12193000	S - 51	80
	S - 95	80
S12194000	S - 52	80
S12195000	G - 128-55	22
	S - 53	80
S12196000	S - 54	80
	S - 96	80
S12197000	S - 106	80
	S - 55	80
	S - 97	80
S12198000	S - 104	80
	S - 56	80
S12199000	S - 116	82
S12200000	S - 103	80
S12201000	S - 59	80
S12205000	K - 1-1-44	30
	K - 2-1-44	36
	K - 3-1-44	42
	K - 4-1-43	48
	K - 5-1-45	54
S12206000	S - 66	80
	S - 78-8	84
S12207000	S - 67	80
	S - 78-10	84
S12208000	S - 68	80
S12209000	S - 69	80
S12210000	S - 70	80
S12211000	S - 72	80
S12212000	S - 73	80
	T - 76	90
S12213000	S - 74	80
S12214000	K - 1-1-30	30
	K - 2-1-30	36
	K - 3-1-30	42
	K - 4-1-30	48
	K - 5-1-30	54
	S - 75	80
	T - 108	92
S12215000	S - 76	80
	T - 75	90
S12216001	W - 1	96
S12217001	W - 4	96
S12222009	Y - 1	98
S12225000	A1 - 3	100
S12230001	A1 - 4	100
S12235009	A1 - 10	100
S12236109	A1 - 13	100
S12239009	A1 - 22	100
S12243001	A1 - 32	100

CODE	REF.NO.	PAGE
S12246001	A1 - 37	100
S12247001	A1 - 38	100
S12249000	A1 - 43	100
S12250009	A1 - 44	100
S12260009	A1 - 60	100
S12271000	L - 38	60
S12276000	G - 116	18
S12279000	K - 1-3-7	32
	K - 2-3-7	38
	K - 3-3-7	44
	K - 4-3-7	50
	K - 5-3-7	56
S12280100	A1 - 71	102
S12283001	B1 - 2-1	104
S12291001	K - 1-1-48	30
	K - 2-1-49	38
	K - 3-1-48	42
	K - 4-1-51	50
	K - 5-1-48	54
S12294001	K - 1-1-49	32
	K - 2-1-50	38
	K - 3-1-49	44
	K - 4-1-52	50
	K - 5-1-49	56
S12297000	K - 1-1-47	30
	K - 2-1-47	36
	K - 3-1-54	44
	K - 4-1-46	48
	K - 5-1-54	56
S12298000	K - 1-3-6	32
	K - 2-3-6	38
	K - 3-3-6	44
	K - 4-3-6	50
	K - 5-3-6	56
	Z2 - 17	112
S12305001	B1 - 3-1	104
S12323001	B1 - 4-1	104
S12341001	B1 - 5-1	104
S12356001	A1 - 74	102
S12359001	A1 - 34	100
S12441001	P - 18-8	70
S12458000	T - 53-1	90
S12459000	T - 53-2	90
S12461001	T - 122-2	92
S12463001	T - 122	92
S12465000	T - 101-2	92
S12466000	A1 - 72	102
	T - 100	90
S12469---	K - 4-1-48	48
S12481000	A1 - 85	102
	N - 83	68
S12482009	N - 82	68
S12483000	N - 74	68
S12484000	N - 75	68
S12487000	K - 1-4-14	32
	K - 2-4-15	38
	K - 3-4-15	44
	K - 4-4-14	50
	K - 5-4-15	56
S12488001	B1 - 2	104
S12489001	B1 - 3	104
S12490001	B1 - 4	104
S12491001	B1 - 5	104
S12494000	K - 6	32
S12495001	S - 78	84
S12506001	A1 - 78	102
S12565009	T - 101-1	92

CODE	REF.NO.	PAGE
S13385001	D - 8	10
S14328000	K - 1-1-54-3	32
	K - 2-1-55-3	38
	K - 3-1-55-3	44
	K - 4-1-57-3	50
	K - 5-1-55-3	56
	S - 115	82
	S - 34	80
S14461009	G - 128	20
S14462009	G - 128-1	20
S14463009	G - 128-4	20
S14464001	G - 128-11	20
S14465009	G - 128-12	20
S14466001	G - 128-15	20
S14468000	G - 128-17	20
S14469000	G - 128-17-1	20
S14470000	G - 128-20	20
S14471000	G - 128-23	20
S14472000	G - 128-23-1	20
S14473000	G - 128-24	20
S14475009	G - 128-28	20
S14477000	G - 128-29	20
S14478001	G - 128-32	20
S14479001	G - 128-34	20
S14480000	G - 128-35	20
S14481009	G - 128-38	20
S14482009	G - 128-39	20
S14483009	G - 128-40	20
S14484009	G - 128-44	20
S14485009	G - 128-48	20
S14486009	G - 128-51	20
S14488000	W - 18	96
S14495000	A - 17	2
S15525001	L - 72	62
S15526001	L - 71	62
S15528001	A1 - 81	102
S15530001	L - 6	60
S15531001	L - 7	60
S15532009	L - 1	60
S15533009	A1 - 19	100
S15538001	H - 19	24
S15539001	H - 20	24
S15542109	L - 10	60
S15545000	H - 79	26
S15547009	A1 - 25	100
S15551001	H - 83	26
S15556009	L - 5	60
S15557009	A1 - 48	100
S15558009	A1 - 84	102
S15561000	S - 88	80
S15562000	S - 88-1	80
S15563000	K - 1-1-54-1	32
	K - 2-1-55-1	38
	K - 3-1-55-1	44
	K - 4-1-57-1	50
	K - 5-1-55-1	56
S15564000	K - 1-1-54	32
	K - 2-1-55	38
	K - 3-1-55	44
	K - 4-1-57	50
	K - 5-1-55	56
S15567000	B1 - 12-1-18	106
	B1 - 13-1-18	108
	L - 39-4	60
S16513000	K - 1-10	32
	K - 2-10	38
	K - 3-10	44

CODE	REF.NO.	PAGE
S16513000	K - 4-10	50
	K - 5-10	56
S16514000	K - 1-9	32
	K - 2-9	38
	K - 3-9	44
	K - 4-9	50
	K - 5-9	56
S16558000	T - 1-7	86
S16661001	T - 62	90
S16667000	Q - 1-27-1	74
S16669000	Q - 1-35	74
S17029000	T - 1-5	86
S17701009	Q - 1	74
S17706001	H - 5	24
S17711101	W - 15	96
S17716009	H - 21	24
S17717009	H - 23	24
S17718000	G - 94	16
S17719009	H - 1	24
S17720009	A1 - 49	100
S17721009	A1 - 89	102
S17722009	A1 - 88	102
S17724001	H - 80	26
S17725000	H - 13	24
S17726000	H - 13-1	24
S19067000	S - 1-2-1	78
S19509000	T - 109	92
S19510000	T - 110	92
S19522001	Q - 1-27	74
S19523201	N - 73	68
S19553000	H - 14	24
	H - 32	24
S19555000	K - 2-1-48	36
	K - 3-1-47	42
	K - 4-1-47	48
	K - 5-1-56	56
S19585000	S - 89	80
S19971000	S - 92	80
S19972000	S - 92-1	80
S20019001	T - 1	86
S20029000	T - 1-12	86
S20038000	T - 1-9	86
S20045000	T - 13	90
S20047000	T - 16	90
S20049000	T - 1-2	86
S20051000	T - 1-11	86
S20053000	T - 1-3	86
S20054000	T - 1-4	86
S20246001	K - 1-1-38	30
	K - 1-1-5	30
	K - 1-4-5	32
	K - 2-1-38	36
	K - 2-1-5	36
	K - 2-4-5	38
	K - 3-1-38	42
	K - 3-1-5	42
	K - 3-4-5	44
	K - 4-1-37	48
	K - 4-1-5	48
	K - 4-4-5	50
	K - 5-1-39	54
	K - 5-1-5	54
	K - 5-4-5	56
	W - 23	96
S20551000	T - 118	92
S20552000	T - 17	90
S20789000	G - 93	16

CODE	REF.NO.	PAGE
S20816001	D - 39	10
S20850001	A1 - 16	100
S20851000	A1 - 90	102
S21083001	T - 21	86
S21121001	K - 14	34
S21122001	K - 15	34
S21123001	K - 16	34
S21186101	V - 2	94
S21190000	T - 113	92
S21191000	T - 137	92
S21193000	T - 114	92
S21194009	T - 2	86
S23325000	V - 3	94
S23326000	V - 4	94
S23328000	T - 138	88
S23329000	T - 139	88
S23392001	G - 70	18
S23394000	G - 125	18
S23395001	G - 129	18
S23396000	L - 43	60
S23397000	L - 43-1	60
S23398001	G - 110	18
S23399001	W - 7	96
S23400001	W - 8	96
S23401001	W - 9	96
S23402001	A1 - 33	100
S23403001	J - 13	28
S23404001	J - 14	28
S23763009	A1 - 91	102
S23836001	R - 41	76
S23848001	M - 25	64
	Z2 - 5	112
S23868000	T - 7	86
S23869200	T - 140	88
S23871001	V - 1	94
S24454001	K - 1-1-2-1	30
	K - 2-1-2-1	36
	K - 3-1-2-1	42
	K - 4-1-2-1	48
	K - 5-1-2-1	54
S24455001	K - 1-1-2-2	30
	K - 2-1-2-2	36
	K - 3-1-2-2	42
	K - 4-1-2-2	48
	K - 5-1-2-2	54
S24456001	K - 1-1-1-1	30
	K - 2-1-1-1	36
	K - 3-1-1-1	42
	K - 4-1-1-1	48
	K - 5-1-1-1	54
S24457001	K - 1-1-1-2	30
	K - 2-1-1-2	36
	K - 3-1-1-2	42
	K - 4-1-1-2	48
	K - 5-1-1-2	54
S24458001	K - 11-1	32
S24459001	K - 11-2	32
S24460001	K - 10-1	32
S24461001	K - 10-2	32
S24560001	G - 59	16
S24564009	A1 - 29	100
S24695009	A - 6	2
S24696009	A - 8	2
S24699001	A - 13	2
S24700001	A - 26	2
S24701001	B - 1	4
S24702000	B - 4	4

CODE	REF.NO.	PAGE
S24703001	B - 5	4
S24704001	B - 17	4
S24705002	B - 19	4
S24705003	B - 19	4
S24705004	B - 19	4
S24705005	B - 19	4
	Z2 - 4	112
S24705006	B - 19	4
S24706001	B - 21	4
S24708001	B - 22	4
S24711000	B - 32	4
S24712001	C - 2	6
S24713001	C - 4	6
S24714001	C - 7	6
S24715001	C - 10	6
S24716001	C - 15	6
S24717000	C - 15-12	6
S24718000	C - 16	6
S24719001	C - 39	6
S24720001	C - 39-1	6
S24721000	C - 40	6
S24722001	C - 42	6
S24723001	C - 43	8
S24724000	C - 46	8
S24725000	C - 47	8
S24726000	C - 48	8
S24727000	C - 48-1	8
S24728000	C - 48-3	8
S24729000	C - 49	8
S24731009	C - 53	8
S24732009	C - 53-3	8
S24733001	E - 1	12
S24734001	E - 2	12
S24735001	E - 4	12
S24736000	E - 13	12
S24737000	E - 14	12
S24738100	E - 16	12
S24739100	E - 17	12
S24740001	D - 5	10
S24741001	D - 6	10
S24742001	D - 7	10
	Z2 - 10	112
	D - 7-1	10
S24743001	Z2 - 10-1	112
	D - 7-2	10
S24744000	Z2 - 10-2	112
S24745000	D - 9	10
S24746009	C - 11	6
S24747009	D - 18	10
S24748001	D - 23	10
S24749001	D - 27	10
S24751000	D - 32	10
S24752000	D - 32-1	10
S24756000	G - 24	14
S24757001	G - 25	14
S24758001	G - 30	14
S24759000	G - 33	14
S24760009	G - 63	16
S24761000	G - 128-64	22
S24762001	H - 40	24
S24763000	H - 58	24
S24764001	H - 59	24
S24765001	H - 64	26
S24766001	H - 71	26
S24767001	J - 17	28
S24768000	J - 26	28
S24769001	J - 35	28

CODE	REF.NO.	PAGE
S24770001	J - 46	28
S24771001	U - 1	94
S24772001	U - 3	94
S24773001	Z1 - 33	110
S24774001	A1 - 7	100
S24775001	A1 - 92	102
S24776001	E - 3	12
S24777000	A1 - 2	100
S24778000	Z1 - 34	110
S24779000	Z1 - 35	110
S24780000	Z2 - 37	112
S24781---	K - 1	30
S24781001	B1 - 7-1	104
S24782---	K - 1-1	30
S24783001	K - 1-1-9	30
	K - 2-1-9	36
	K - 3-1-9	42
	K - 4-1-9	48
	K - 5-1-9	54
S24784001	K - 1-1-10	30
	K - 2-1-10	36
	K - 3-1-10	42
	K - 4-1-10	48
	K - 5-1-10	54
S24785000	K - 1-1-17	30
	K - 2-1-17	36
	K - 3-1-17	42
	K - 4-1-17	48
	K - 5-1-17	54
S24786000	K - 1-1-18	30
	K - 2-1-18	36
	K - 3-1-18	42
	K - 4-1-18	48
	K - 5-1-18	54
S24787000	K - 1-1-26	30
	K - 2-1-26	36
	K - 3-1-26	42
	K - 4-1-26	48
	K - 5-1-26	54
S24788000	K - 1-1-27	30
	K - 2-1-27	36
	K - 3-1-27	42
	K - 4-1-27	48
	K - 5-1-27	54
S24789000	K - 1-1-40	30
	K - 2-1-40	36
	K - 3-1-40	42
	K - 4-1-39	48
	K - 5-1-41	54
S24790000	K - 1-1-40-1	30
	K - 2-1-40-1	36
	K - 3-1-40-1	42
	K - 4-1-39-1	48
	K - 5-1-41-1	54
S24791---	K - 1-1-46	30
S24792---	K - 1-2	32
S24793---	K - 1-2-9	32
S24794---	K - 1-3	32
S24795---	K - 1-3-5	32
S24796---	K - 1-4	32
S24797---	K - 2	36
S24797001	B1 - 8-1	104
S24798---	K - 2-1	36
S24799---	K - 2-1-46	36
S24800---	K - 2-2	38
S24801000	K - 2-2-9	38
S24802000	K - 1-2-11	32

CODE	REF.NO.	PAGE
S24802000	K - 2-2-11	38
	K - 3-2-11	44
	K - 4-2-11	50
	K - 5-2-11	56
S24805---	K - 2-3	38
S24806---	K - 2-3-5	38
S24807---	K - 2-4	38
S24808---	K - 3	42
S24808001	B1 - 9-1	104
S24809---	K - 3-1	42
S24810---	K - 3-1-46	42
S24811---	K - 3-2	44
S24812---	K - 3-2-9	44
S24813---	K - 3-3	44
S24814---	K - 3-3-5	44
S24815---	K - 3-4	44
S24816---	K - 3-4-6	44
S24817---	K - 4	48
S24817001	B1 - 10-1	104
S24818---	K - 4-1	48
S24819---	K - 4-1-45	48
S24820---	K - 4-2-9	50
S24821---	K - 4-3	50
S24822---	K - 4-3-5	50
S24823---	K - 4-4	50
S24824---	K - 4-4-6	50
S24825---	K - 4-2	50
S24826---	K - 1-4-6	32
S24827---	K - 2-4-6	38
S24828000	K - 17	34
S24830001	J - 38	28
S24831001	J - 39	28
S24832001	H - 49	24
S24833---	K - 5	54
S24833001	B1 - 11-1	104
S24834---	K - 5-1	54
S24835---	K - 5-1-32	54
S24836---	K - 5-1-33	54
S24837---	K - 5-1-34	54
S24838---	K - 5-1-35	54
S24839---	K - 5-1-36	54
	K - 5-1-47	54
S24841---	K - 1-1-32	30
S24842---	K - 1-1-33	30
S24843---	K - 1-1-34	30
S24844---	K - 1-1-35	30
S24845---	K - 2-1-32	36
S24846---	K - 2-1-33	36
S24847---	K - 2-1-34	36
S24848---	K - 2-1-35	36
S24849---	K - 3-1-32	42
S24850---	K - 3-1-33	42
S24851---	K - 3-1-34	42
S24852---	K - 3-1-35	42
S24853---	K - 4-1-32	48
S24854---	K - 4-1-33	48
S24855---	K - 4-1-34	48
S24856---	K - 4-1-49	50
S24857---	K - 4-1-50	50
S24858---	K - 4-1-59	50
S24859---	K - 4-1-60	50
S24860---	K - 4-1-61	50
S24861---	K - 1-4-7	32
S24862---	K - 1-4-8	32
S24863---	K - 1-4-9	32
S24864---	K - 2-4-7	38
S24865---	K - 2-4-8	38

CODE	REF.NO.	PAGE
S24866---	K - 2-4-9	38
S24867---	K - 2-4-10	38
S24868---	K - 3-4-7	44
S24869---	K - 3-4-8	44
S24870---	K - 3-4-9	44
S24871---	K - 3-4-10	44
S24872---	K - 4-4-7	50
S24873---	K - 4-4-8	50
S24874---	K - 4-4-9	50
S24875---	K - 5-2	56
S24876---	K - 5-2-9	56
S24877---	K - 5-3	56
S24878---	K - 5-3-5	56
S24879---	K - 5-4	56
S24880---	K - 5-4-6	56
S24881---	K - 5-4-7	56
S24882---	K - 5-4-8	56
S24883---	K - 5-4-9	56
S24884---	K - 5-4-10	56
S24885001	B1- 11	104
S24886001	K - 1-1-1	30
	K - 2-1-1	36
	K - 3-1-1	42
	K - 4-1-1	48
	K - 5-1-1	54
S24887001	K - 1-1-2	30
	K - 2-1-2	36
	K - 3-1-2	42
	K - 4-1-2	48
	K - 5-1-2	54
S24888001	K - 10	32
S24889001	K - 11	32
S24890001	K - 18	34
S24893000	K - 22	34
S24894009	A1- 94	102
S24895001	S - 114	82
S24901001	M - 3	64
S24902001	M - 14	64
S24903001	M - 23-1	64
S24903901	M - 23-2	64
S24904001	M - 24	64
S24905001	M - 24-1	64
S24909000	N - 1	66
S24910000	N - 3	66
S24911000	N - 4	66
S24912000	N - 5	66
S24915001	N - 6	66
S24916000	N - 8	66
S24917000	N - 13	66
	N - 34	66
S24918000	N - 18	66
S24919000	N - 19	66
S24920001	N - 20	66
S24921009	N - 33	66
S24922000	N - 35	66
S24923000	N - 42	66
S24924001	N - 65	68
S24925000	N - 15	66
S24926000	N - 16	66
S24927001	P - 2	70
S24929000	P - 21	70
	P - 9	70
S24930000	P - 21-3	70
	P - 9-3	70
S24931001	P - 12	70
S24932001	P - 20	70
S24933001	P - 24	70

CODE	REF.NO.	PAGE
S24934009	P - 32	70
S24935009	P - 34	70
S24936001	P - 39	72
S24937001	S - 1	78
S24938001	S - 1-2	78
S24939000	S - 1-3	78
S24940000	S - 1-3-1	78
S24941001	S - 6	84
S24942001	S - 7	78
S24943000	S - 7-1	78
S24944001	S - 79	84
S24945001	S - 79-1	84
S24946000	S - 79-3	84
S24947000	S - 79-3-1	84
S24948001	S - 79-4	84
S24949000	S - 79-5	84
S24950001	S - 79-13	84
S24951000	S - 79-13-1	84
S24952000	S - 79-14	84
S24953000	S - 90	80
S24954001	T - 101	92
S24955001	T - 101-4	92
S24956001	B1- 12-11	106
	T - 101-5	92
	T - 101-7	92
S24957001	T - 101-7	92
S24958001	W - 17	96
S24959009	X - 1	98
S24960009	X - 4	98
S24962001	P - 41	72
S24963009	X - 11	98
S24964000	X - 13	98
S24965000	X - 13-1	98
S24966000	X - 13-2	98
S24968009	A1- 41	100
S24969009	A1- 45	100
S24970009	A1- 46	100
S24971009	A1- 50	100
S24972009	A1- 53	100
S24973009	A1- 54	100
S24974009	A1- 57	100
S24975001	A1- 63	100
S24976001	A1- 64	100
S24977001	A1- 66	102
S24978001	A1- 67	102
S24979001	A1- 69	102
S24982000	Z1 - 24	110
S24983000	Z1 - 25	110
S24984000	Z1 - 26	110
S24985000	Z1 - 27	110
S24986000	Z1 - 28	110
S24987001	Z1 - 32	110
S24988001	Z1 - 32-1	110
S24989001	Z1 - 32-2	110
S24990001	Z1 - 32-3	110
S25021001	B1 - 7	104
S25022001	B1 - 8	104
S25023001	B1 - 9	104
S25024001	B1 - 10	104
S25025001	B1 - 12	106
S25026001	B1 - 12-1	106
	B1 - 13-1	108
S25027001	B1 - 12-1-1	106
	B1 - 13-1-1	108
S25028001	B1 - 12-1-5	106
	B1 - 13-1-5	108
S25029001	B1 - 12-1-6	106
	B1 - 13-1-6	108

CODE	REF.NO.	PAGE
S25030001	B1 - 12-1-9	106
	B1 - 13-1-9	108
S25031001	B1 - 12-1-10	106
	B1 - 13-1-10	108
S25032001	B1 - 12-1-11	106
	B1 - 13-1-11	108
S25033001	B1 - 12-1-13	106
	B1 - 13-1-13	108
S25034001	B1 - 12-1-15	106
	B1 - 13-1-15	108
S25036000	B1 - 12-1-17	106
	B1 - 13-1-17	108
S25037000	B1 - 12-1-22	106
	B1 - 13-1-22	108
S25038000	B1 - 12-1-22-1	106
	B1 - 13-1-22-1	108
S25039001	S - 110	80
S25040000	B1 - 12-2	106
	B1 - 13-2	108
S25041000	S - 112	80
S25044000	B1 - 12-3	106
	B1 - 13-3	108
S25045001	B1 - 12-4	106
	B1 - 13-4	108
S25046001	B1 - 12-7	106
S25047001	B1 - 13	108
S25050000	B1 - 12-16	106
	B1 - 13-13	108
S25051000	S - 105	80
S25054000	S - 108	80
S25055009	G - 20	14
S25056001	S - 79-8	84
S25057001	S - 79-7	84
S25058000	S - 79-9	84
S25100000	S - 109	84
S25205000	T - 59	86
S25206000	T - 28	86
S25207000	T - 29	86
S25208000	T - 22	86
S25209000	T - 24	90
S25210000	T - 25	90
S25575000	T - 26	90
S25576000	T - 36	90
S25577000	T - 37	90
S25578000	T - 38	90
S25579100	T - 33	90
S25580100	T - 34	90
S25581100	T - 35	90
S25582000	T - 23	86
S25583000	T - 40	86
S25584000	T - 102	88
S25585000	T - 9	86
S25868000	T - 107	92
S27926000	S - 79-17	84
S27927000	T - 142	92
S27929000	T - 147	92
S27931000	T - 148	92
S27932009	A1 - 47	100
S27933000	T - 145	92
S27934000	T - 146	92
S27935000	T - 149	92
S29181---	K - 1-2-7	32
S29182---	K - 1-2-10	32
S29183---	K - 2-2-7	38
S29184---	K - 2-2-10	38
S29185---	K - 3-2-7	44
S29186---	K - 3-2-10	44

CODE	REF.NO.	PAGE
S29187---	K - 4-2-7	50
S29188---	K - 4-2-10	50
S29189---	K - 5-2-7	56
S29190---	K - 5-2-10	56
S29240000	S - 92-2	80
S29467000	T - 115-2	92
S29468001	F - 1	12
S29470000	T - 115	92
S29885009	A - 10	2
U42775001	B1 - 10-2	104
	B1 - 11-2	104
	B1 - 2-2	104
	B1 - 3-2	104
	B1 - 4-2	104
	B1 - 5-2	104
	B1 - 7-2	104
	B1 - 8-2	104
	B1 - 9-2	104
	Z2 - 16	112
002300803	T - 2-17	86
003400804	T - 101-9	92
004300513	Q - 1-2	74
004400702	A1 - 70	102
	G - 32	14
	S - 79-10	84
004400804	A1 - 52	100
	G - 126	18
	G - 128-36	20
004401414	S - 79-2	84
008400604	A1 - 42	100
	A1 - 51	100
	A1 - 87	102
	A1 - 93	102
	G - 113	18
	G - 119	18
	H - 24	24
	J - 52	28
008400806	A1 - 86	102
	N - 81	68
013660612	R - 6	76
013781012	B - 14	4
	B - 24	4
	B - 26	4
014060632	G - 41	14
	G - 58	16
	J - 10	28
	J - 12	28
	J - 20	28
	L - 26	60
	L - 32	60
	L - 73	62
	S - 113	80
014300332	Q - 1-6	74
014400422	A - 23	2
	D - 21	10
	X - 10	98
014400522	B1 - 12-1-8	106
	B1 - 13-1-8	108
	G - 12	14
	G - 77	16
	G - 80	16
	H - 72	26
	J - 44	28
	K - 1-1-20	30
	K - 2-1-20	36
	K - 3-1-20	42
	K - 4-1-20	48

CODE	REF.NO.	PAGE	
014400522	K - 5-1-20	54	
	P - 17	70	
	S - 33	78	
014400822	M - 16	64	
	P - 29	70	
	R - 26	76	
	R - 45	76	
014500522	A - 29	2	
	A - 32	2	
	D - 31	10	
	G - 128-33	20	
	G - 88	16	
	G - 92	16	
	G - 97	16	
	H - 63	26	
	H - 68	26	
	K - 1-2-5	32	
	K - 1-4-3	32	
	K - 2-2-5	38	
	K - 2-4-3	38	
	K - 3-2-5	44	
	K - 3-4-3	44	
	K - 4-2-5	50	
	K - 4-4-3	50	
	K - 5-2-5	56	
	K - 5-4-3	56	
	L - 17	60	
	Q - 1-9	74	
	014680422	C - 15-11	6
		C - 15-14	6
		C - 15-7	6
		R - 41-1	76
	014710522	X - 12	98
		D - 19	10
014760622	B - 28	4	
	C - 27	6	
	C - 45	8	
	M - 2	64	
014770622	C - 1-2	6	
	C - 15-5	6	
	C - 31	6	
	C - 5	6	
	C - 6-2	6	
	C - 8	6	
	D - 26	10	
	M - 13	64	
	M - 32	64	
	R - 3	76	
	014771022	C - 51	8
		S - 2	78
	017771412	S - 15	78
018060822	G - 44	16	
018061022	G - 53	16	
018061422	G - 9	14	
018062022	G - 49	16	
	G - 67	16	
	J - 2	28	
	J - 28	28	
	L - 63	62	
	L - 74	62	
018062522	G - 19	14	
	G - 40	14	
	G - 57	16	
	L - 65	62	
018063022	X - 3	98	
	J - 15	28	
	J - 31	28	

CODE	REF.NO.	PAGE	
018081222	G - 35	14	
018081422	A1- 30	100	
	G - 6	14	
018081622	L - 11	60	
	S - 78-2	84	
018082022	A1- 20	100	
	A1- 23	100	
	A1- 26	100	
	A1- 61	100	
	H - 60	24	
	H - 65	26	
	H - 74	26	
018082522	T - 14	90	
	G - 2	14	
	L - 4	60	
	S - 79-18	84	
018300532	K - 1-4-10	32	
	K - 1-4-15	32	
	K - 2-4-11	38	
	K - 2-4-16	38	
	K - 3-4-11	44	
	K - 3-4-16	44	
	K - 4-4-10	50	
	K - 4-4-15	50	
	K - 5-4-11	56	
	K - 5-4-16	56	
	018301222	B1- 12-1-20	106
B1- 13-1-20		108	
018400632	K - 1-1-28	30	
	K - 2-1-28	36	
	K - 3-1-28	42	
	K - 4-1-28	48	
	K - 5-1-28	54	
	A1- 17	100	
018400822	K - 3-1-11	42	
	K - 5-1-11	54	
	L - 51	62	
	N - 66	68	
	T - 3	86	
	T - 31	90	
	018400832	A1- 11	100
		A1- 5	100
		A1- 8	100
		B1- 12-1-2	106
		B1- 13-1-2	108
G - 128-41		20	
G - 128-8		20	
H - 50		24	
H - 6		24	
H - 81		26	
J - 36		28	
J - 40		28	
K - 1-1-11		30	
K - 2-1-11	36		
K - 4-1-11	48		
018401022	L - 19	60	
	N - 86	68	
	S - 1-8	78	
	T - 86	90	
	A1- 82	102	
	G - 108	18	
	G - 128-2	20	
	G - 86	16	
	K - 1-3-2	32	
	K - 2-3-2	38	
	K - 3-3-2	44	
	K - 4-3-2	50	

CODE	REF.NO.	PAGE	
018401022	K - 5-3-2	56	
	X - 8	98	
	Z1 - 32-4	110	
018401222	G - 71	18	
	T - 105	88	
018401422	M - 22	64	
018401622	A1 - 55	100	
	G - 100	16	
	G - 103	18	
	G - 128-37	20	
	G - 82	16	
	H - 41	24	
	J - 33	28	
	S - 25	78	
	018402022	S - 79-11	84
		K - 1-2-3	32
	018402032	K - 2-2-3	38
		K - 3-2-3	44
		K - 4-2-3	50
		K - 5-2-3	56
		X - 16	98
018402522		G - 128-58	22
		018403022	K - 1-1-42
K - 2-1-42	36		
K - 3-1-42	42		
K - 4-1-41	48		
K - 5-1-43	54		
S - 64	80		
018500822	G - 128-18		20
	G - 128-21	20	
	K - 1-1-36	30	
	K - 2-1-36	36	
	K - 3-1-36	42	
	K - 4-1-35	48	
	K - 5-1-37	54	
018501022	G - 123	18	
	G - 128-45	20	
	G - 128-49	20	
	G - 128-52	20	
	G - 27	14	
018501222	A1 - 58	100	
	E - 6	12	
	G - 64	16	
	L - 41	60	
018501622	L - 45	62	
	A - 27	2	
	G - 111	18	
018502022	G - 128-26	20	
	G - 128-5	20	
	H - 11	24	
	H - 47	24	
	J - 42	28	
	W - 10	96	
	W - 13	96	
	W - 2	96	
	A1 - 73	102	
	B1 - 12-12	106	
	G - 128-13	20	
	G - 128-16	20	
	G - 130	18	
	H - 27	24	
	H - 44	24	
K - 1-1-1-3	30		
K - 1-1-2-3	30		
K - 10-3	32		
K - 11-3	32		
K - 2-1-1-3	36		

CODE	REF.NO.	PAGE	
018502022	K - 2-1-2-3	36	
	K - 3-1-1-3	42	
	K - 3-1-2-3	42	
	K - 4-1-1-3	48	
	K - 4-1-2-3	48	
	K - 5-1-1-3	54	
	K - 5-1-2-3	54	
	T - 101-6	92	
	T - 119	92	
	W - 12	96	
	W - 19	96	
	W - 5	96	
	018502222	A1 - 14	100
		018502522	A1 - 39
	H - 54		24
K - 1-1-3	30		
K - 1-4-2	32		
K - 2-1-3	36		
K - 2-4-2	38		
K - 3-1-3	42		
K - 3-4-2	44		
K - 4-1-3	48		
K - 4-4-2	50		
K - 5-1-3	54		
K - 5-4-2	56		
W - 21	96		
018503022	S - 1-4		78
	S - 8		78
	W - 20	96	
021060206	K - 1-1-53	32	
	K - 2-1-54	38	
	K - 3-1-53	44	
	K - 4-1-56	50	
	K - 5-1-53	56	
	S - 78-9	84	
021080302	A1 - 75	102	
	021200203	L - 55	62
021400103		Q - 1-26	74
		021400202	Z2 - 22-1
Z2 - 6-4-2	112		
Z2 - 6-7-3	112		
021500106	T - 125	92	
	T - 2-18	86	
025030132	T - 90	88	
025030133	K - 1-4-12	32	
	K - 2-4-13	38	
	K - 3-4-13	44	
025030232	K - 4-4-12	50	
	K - 5-4-13	56	
	Q - 1-30	74	
025030233	T - 91	88	
	025040232	A1 - 56	100
B1 - 12-1-3		106	
B1 - 13-1-3		108	
G - 128-10		20	
H - 52		24	
H - 57		24	
H - 8		24	
H - 84		26	
Q - 1-23		74	
T - 5		86	
T - 85		90	
025040233		A - 40	2
		B1 - 12-10	106
		B1 - 12-6	106
		B1 - 13-6	108
	B1 - 13-9	108	

CODE	REF.NO.	PAGE	
025040233	G - 128-43	20	
	G - 128-62	22	
	G - 61	16	
	H - 35	24	
	H - 38	24	
	J - 51	28	
	K - 1-1-8	30	
	K - 2-1-8	36	
	K - 21	34	
	K - 3-1-8	42	
	K - 4-1-8	48	
	K - 5-1-8	54	
	L - 61	62	
	N - 88	68	
	P - 15	70	
	P - 27	70	
	T - 12	86	
	T - 136	88	
	T - 153	88	
	T - 50	86	
	T - 84	90	
	T - 97	88	
	W - 29	96	
	T - 121	92	
	025050132	E - 8	12
		G - 128-47	20
	025050232	G - 128-54	20
		G - 29	14
	025060232	G - 46	16
		G - 51	16
		G - 69	16
		J - 29	28
		L - 67	62
		L - 75	62
	025080232	S - 98	80
		A1 - 80	102
G - 37		14	
G - 4		14	
025350132	S - 78-4	84	
	D - 41	10	
025710232	N - 30	66	
025900232	B - 31	4	
028030242	B1 - 12-1-21	106	
	B1 - 13-1-21	108	
028030243	F - 4	12	
	K - 1-4-11	32	
	K - 1-8	32	
	K - 2-4-12	38	
	K - 2-8	38	
	K - 3-4-12	44	
	K - 3-8	44	
	K - 4-4-11	50	
	K - 4-8	50	
	K - 5-4-12	56	
	K - 5-8	56	
	N - 63	66	
	T - 117	92	
	T - 122-4	92	
	T - 124	92	
	H - 31	24	
	K - 1-1-15	30	
	K - 2-1-15	36	
	K - 3-1-15	42	
	K - 4-1-15	48	
	K - 5-1-15	54	
	L - 29	60	
	L - 35	60	

CODE	REF.NO.	PAGE	
028030243	L - 58	62	
	S - 79-6	84	
	T - 144	92	
	T - 2-19	86	
	T - 64	90	
	T - 89	88	
	028040242	A1 - 12	100
		A1 - 18	100
		A1 - 6	100
		A1 - 83	102
A1 - 9		100	
B1 - 12-1-4		106	
B1 - 13-1-4		108	
G - 101		16	
G - 104		18	
G - 109		18	
G - 128-3		20	
G - 128-59		22	
G - 128-9		20	
G - 72		18	
G - 83		16	
H - 42		24	
H - 51		24	
H - 7		24	
H - 82		26	
J - 34		28	
J - 37		28	
J - 41		28	
K - 1-1-12		30	
K - 1-1-29		30	
K - 1-1-41		30	
K - 1-2-4		32	
K - 1-3-3		32	
K - 2-1-12		36	
K - 2-1-29		36	
K - 2-1-41		36	
K - 2-2-4		38	
K - 2-3-3		38	
K - 3-1-12		42	
K - 3-1-29	42		
K - 3-1-41	42		
K - 3-2-4	44		
K - 3-3-3	44		
K - 4-1-12	48		
K - 4-1-29	48		
K - 4-1-40	48		
K - 4-2-4	50		
K - 4-3-3	50		
K - 5-1-12	54		
K - 5-1-29	54		
K - 5-1-42	54		
K - 5-2-4	56		
K - 5-3-3	56		
L - 20	60		
L - 52	62		
L - 54	62		
N - 67	68		
N - 87	68		
Q - 1-24	74		
Q - 1-34	74		
S - 1-9	78		
S - 22	78		
S - 26	78		
S - 65	80		
S - 79-12	84		
T - 106	88		
T - 32	90		

CODE	REF.NO.	PAGE
028040242	T - 4	86
	T - 87	90
	X - 18	98
028040243	X - 6	98
	A1 - 36	100
	B1 - 12-9	106
	B1 - 13-8	108
	E - 12	12
	G - 128-31	20
	G - 128-42	20
	K - 1-1-51	32
	K - 2-1-52	38
	K - 20	34
	K - 3-1-51	44
	K - 4-1-54	50
	K - 5-1-51	56
	P - 11	70
	P - 14	70
	P - 23	70
	P - 26	70
Q - 3	74	
028050242	T - 101-10	92
	T - 83	90
	A1 - 15	100
	A1 - 40	100
	A1 - 59	100
	E - 7	12
	G - 124	18
	G - 128-19	20
	G - 128-22	20
	G - 128-27	20
	G - 128-46	20
	G - 128-50	20
	G - 128-53	20
	G - 128-6	20
	G - 131	18
	G - 16	14
	G - 28	14
	G - 65	16
	H - 12	24
	H - 28	24
	H - 45	24
	H - 48	24
	J - 43	28
	K - 1-1-1-4	30
	K - 1-1-2-4	30
	K - 1-1-37	30
	K - 1-1-4	30
	K - 10-4	32
	K - 11-4	32
	K - 2-1-1-4	36
	K - 2-1-2-4	36
	K - 2-1-37	36
	K - 2-1-4	36
	K - 3-1-1-4	42
	K - 3-1-2-4	42
	K - 3-1-37	42
	K - 3-1-4	42
K - 4-1-1-4	48	
K - 4-1-2-4	48	
K - 4-1-36	48	
K - 4-1-4	48	
K - 5-1-1-4	54	
K - 5-1-2-4	54	
K - 5-1-38	54	
K - 5-1-4	54	
L - 42	60	

CODE	REF.NO.	PAGE
028050242	L - 46	62
	S - 1-5	78
	S - 9	78
	T - 120	92
	W - 11	96
	W - 14	96
	W - 22	96
	W - 24	96
	W - 3	96
	W - 6	96
028050243	C - 50	8
	G - 117	18
	G - 128-25	20
028050246	H - 15	24
	Z2 - 6-7-2	112
028060242	G - 10	14
	G - 45	16
	G - 50	16
	G - 54	16
	G - 68	16
	H - 77	26
	J - 16	28
	J - 3	28
	J - 30	28
	L - 64	62
	L - 66	62
	L - 76	62
	S - 16	78
	S - 3	78
	X - 2	98
	028060243	K - 1-1-52
K - 2-1-53		38
K - 3-1-52		44
K - 4-1-55		50
K - 5-1-52		56
028080242		A1 - 21
	A1 - 24	100
	A1 - 27	100
	A1 - 31	100
	A1 - 62	100
	G - 3	14
	G - 36	14
	G - 7	14
	H - 61	26
	H - 66	26
	H - 75	26
	L - 12	60
	L - 3	60
	S - 78-3	84
S - 79-19	84	
T - 15	90	
028350242	D - 42	10
	P - 38	70
034311302	Y - 1-3	98
047301042	Q - 1-16	74
048040342	B1 - 12-1-12	106
	B1 - 13-1-12	108
048050342	D - 17	10
	D - 38	10
	C - 18	6
	K - 1-1-23	30
	K - 1-1-25	30
	K - 2-1-23	36
	K - 2-1-25	36
	K - 3-1-23	42
	K - 3-1-25	42
	K - 4-1-23	48

CODE	REF.NO.	PAGE
048050342	K - 4-1-25	48
	K - 5-1-23	54
	K - 5-1-25	54
048060342	R - 36	76
048070342	D - 35	10
048080142	M - 33	64
048120142	C - 14	6
	G - 128-14	20
	G - 23	14
048150142	B - 29-4	4
	B - 9	4
048170145	M - 11	64
	R - 12	76
048220242	M - 26	64
048320242	B - 10	4
048350242	B - 29-3	4
	H - 4	24
	M - 8	64
048370242	C - 13	6
050501406	Z2 - 6-7-5	112
050503006	Z2 - 22-3	112
052400806	Z2 - 6-7-4	112
	A1 - 77	102
	T - 58	90
060300414	W - 27	96
	B1 - 12-1-14	106
	B1 - 13-1-14	108
060400816	K - 1-2-8	32
	K - 2-2-8	38
	K - 3-2-8	44
	K - 4-2-8	50
	K - 5-2-8	56
	B1 - 12-1-7	106
060660512	B1 - 13-1-7	108
	Q - 1-14	74
060670612	P - 31	70
061302506	P - 37	70
	C1 - 1-8	110
062300502	K - 1-7	32
	K - 2-7	38
	K - 3-7	44
	K - 4-7	50
	K - 5-7	56
	T - 47	90
	T - 88	88
062300506	T - 143	92
	T - 123	92
062300606	Q - 1-29	74
062300612	T - 63	90
062300616	A1 - 35	100
	E - 11	12
	K - 19	34
062400806	B1 - 12-5	106
	B1 - 13-5	108
	G - 128-30	20
	G - 128-61	22
	G - 62	16
	H - 34	24
	H - 37	24
	H - 56	24

CODE	REF.NO.	PAGE	
062400806	J - 50	28	
	L - 60	62	
	N - 89	68	
	P - 13	70	
	Q - 2	74	
	T - 101-8	92	
	T - 11	86	
	T - 152	88	
	T - 49	86	
	T - 96	88	
	W - 28	96	
	062400812	N - 21	66
		P - 33	70
		R - 9	76
062401006	S - 21	78	
	X - 5	98	
	A - 20	2	
	K - 1-1-50	32	
	K - 1-1-7	30	
	K - 2-1-51	38	
	K - 2-1-7	36	
	K - 3-1-50	44	
	K - 3-1-7	42	
	K - 4-1-53	50	
	K - 4-1-7	48	
	K - 5-1-50	56	
	K - 5-1-7	54	
	P - 25	70	
062401012	T - 134	88	
	T - 82	90	
062401212	A - 7	2	
	A - 9	2	
	B - 8	4	
	M - 10	64	
	N - 39	66	
	Q - 1-25	74	
	Q - 1-33	74	
	A - 12	2	
	P - 35	70	
	X - 14	98	
T - 135	88		
062401412	A - 21	2	
	B1 - 12-8	106	
062401416	B1 - 13-7	108	
062401616	P - 10	70	
	P - 22	70	
062402016	E - 5	12	
062501202	Z2 - 6-4-1	112	
062501406	A - 16	2	
	N - 7	66	
062670612	N - 7	66	
062680512	C - 24	6	
062680612	A1 - 65	102	
	A1 - 68	102	
	A1 - 79	102	
062680812	S - 23	78	
062681012	C - 33	6	
062711012	N - 29	66	
062711412	D - 29	10	
	R - 21	76	
062762012	H - 76	26	
072060860	M - 27	64	
072620260	B - 29-2	4	
072630140	M - 5	64	
	C - 9	6	
076002450	J - 4	28	
081001670	N - 12	66	
081005670	N - 55	66	

CODE	REF.NO.	PAGE
081024070	N - 49	66
081030070	N - 27	66
100022005	C - 37	6
100032003	E - 19	12
	P - 8	70
100136001	Q - 1-21	74
100251001	B - 11-2	4
	B - 6	4
	R - 30	76
100257010	D - 40	10
100328001	C - 55	8
100360003	U - 4	94
100401001	Q - 1-20	74
100402004	P - 18-3	70
100645003	R - 8	76
	X - 17	98
100887001	Z2 - 3-1	112
101572101	Z2 - 2-3	112
101706001	M - 17-1	64
102571003	R - 18	76
102843004	D - 7-3	10
	E - 15	12
	R - 5	76
	Z1 - 29	110
	Z2 - 10-3	112
103950003	P - 19	70
104449009	A - 33	2
104450109	A - 34	2
104464001	B - 12	4
104821001	A - 39	2
104821009	A - 35	2
	N - 28	66
105077000	B - 16	4
105176001	C - 12	6
105234003	R - 29	76
106147002	N - 78	68
106629002	N - 62	66
107272002	A - 25	2
	Z1 - 31	110
107780001	Z2 - 3-2	112
108549001	C - 53-6	8
110201001	R - 42	76
110367001	B - 15	4
	R - 35	76
110558001	N - 64	68
111466001	D - 1	10
111865009	C - 57	8
111942001	Q - 1-12	74
111943001	Q - 1-13	74
112751002	P - 40	72
112758009	N - 32	66
113431002	H - 85	26
114294001	P - 18-10	70
114483002	Z2 - 8	112
114486002	N - 79	68
115007001	C - 28	6
	M - 20	64
115157001	Z2 - 3-7	112
116112001	P - 28	70
116922001	P - 18-2	70
117671002	C - 30	6
117934009	L - 62	62
118064001	Z2 - 3-5	112
118352001	B1 - 12-1-23	106
	B1 - 13-1-23	108
118837001	Z2 - 2-2	112
122991001	Z2 - 1	112

CODE	REF.NO.	PAGE
126863001	Z2 - 6-10	112
129458002	C - 53-5	8
129500010	C - 53-2	8
133172003	N - 80	68
140004001	B - 13-2	4
140208001	N - 51	66
140542001	S - 84	82
140553102	B - 20	4
140647001	N - 10	66
	N - 58	66
140682001	S - 1-2-5	78
	S - 6-5	84
	S - 7-5	78
141207001	D - 3	10
141309001	C - 1-1	6
141334001	C - 36	6
142403001	D - 10	10
142443001	Z2 - 2-1	112
142628001	B - 23	4
142721001	Z2 - 3-4	112
142746002	C - 53-4	8
143361000	S - 79-16	84
143488000	R - 37-2	76
143609001	C - 35	6
144105000	P - 6	70
144504001	P - 16-3	70
144508001	N - 77	68
145446001	P - 18-5	70
	P - 3	70
	Q - 1-19	74
145465001	B - 13-1	4
145472001	D - 2	10
145474001	D - 14	10
145478001	D - 24	10
145480001	C - 20	6
145502001	C - 54	8
145522001	P - 30	70
145571101	Q - 1-18	74
145580001	D - 13	10
145624000	B - 13-4	4
	N - 90	68
146049001	Z2 - 3-3	112
146153001	D - 37	10
146197001	Q - 1-22	74
146293001	C - 29	6
146581001	C - 44	8
146629000	D - 30	10
147251009	A - 36	2
147557101	P - 1	70
147777000	B - 13-3	4
147846002	D - 4	10
148294001	B1 - 12-1-16	106
	B1 - 13-1-16	108
148537001	R - 15	76
	U - 2	94
148851001	P - 5	70
149173001	Z2 - 2-4	112
149287000	H - 36	24
149438000	S - 78-1-2	84
149547000	A - 18	2
	J - 48	28
	N - 85	68
	T - 127	88
	T - 98	88
	W - 25	96
149796001	S - 17	78
149809000	T - 126	92

CODE	REF.NO.	PAGE
149809000	T - 69	90
150106003	Z2 - 6-4	112
150145009	Z2 - 22	112
150172003	Z2 - 6-3	112
150174000	Z2 - 6-2-3	112
	Z2 - 6-5	112
150179002	Z2 - 6-7-1	112
150180001	Z2 - 6-8	112
150182000	Z2 - 6-9	112
150185009	Z2 - 22-2	112
150191002	Z2 - 6-2-2	112
150206002	Z2 - 6-2-1	112
150332001	Z2 - 2-5	112
150335001	Z2 - 3-6	112
150349001	T - 72	86
150353001	S - 79-13-2	84
150357001	T - 73	88
150554002	C - 52	8
150756009	A - 37	2
150949001	J - 18	28
151276001	C - 56	8
151594001	B - 18	4
151827000	T - 103	88
151987001	R - 17	76
152358001	Q - 1-5	74
152361001	Q - 1-10	74
152362001	Q - 1-11	74
152363001	Q - 1-15	74
152364001	Q - 1-17	74
152429000	T - 2-16	86
152430000	T - 2-15	86
152507000	Q - 1-27-2	74
152508000	Q - 1-27-3	74
152509000	Q - 1-27-4	74
	S - 1-3-4	78
152510000	T - 8	90
152565000	T - 1-10	86
	Z2 - 15	112
152645001	Q - 1-28	74
152858001	H - 70	26
152859001	H - 69	26
152866001	A - 28	2
152867000	A - 31	2
152868009	A - 30	2
152914001	X - 15	98
152937001	F - 5	12
152948001	N - 47	66
153112001	N - 50	66
153138001	C - 19	6
153252000	S - 14-3	78
153274001	S - 6-7	84
	S - 7-7	78
154024001	Q - 1-7	74
154092001	Q - 1-8	74
154125001	Z2 - 3-8	112
154468001	N - 76	68
154562001	P - 16-4	70
154567000	R - 2	76
154576001	R - 16	76
154578000	R - 20	76
154581001	R - 25	76
154582001	R - 27	76
154590001	R - 28	76
154593001	R - 31	76
154594000	R - 32	76
154595001	R - 33	76
154596000	R - 34	76

CODE	REF.NO.	PAGE
154598001	R - 38	76
154599000	R - 39	76
154702001	Z2 - 7	112
154778000	S - 79-15	84
156112003	Z2 - 6-1	112
156619001	R - 10	76
156620000	R - 11	76
156623001	R - 22	76
157840000	N - 44	66
157843001	N - 43	66
157844000	N - 48	66
157875000	T - 2-12	86
158597001	Q - 1-31	74
158598009	Q - 1-32	74
158722002	K - 1-1-39	30
	K - 1-2-2	32
	K - 1-3-4	32
	K - 2-1-39	36
	K - 2-2-2	38
	K - 2-3-4	38
	K - 3-1-39	42
	K - 3-2-2	44
	K - 3-3-4	44
	K - 4-1-38	48
	K - 4-2-2	50
	K - 4-3-4	50
	K - 5-1-40	54
	K - 5-2-2	56
	K - 5-3-4	56
158726001	B - 13-5	4
158727001	B - 13-6	4
158882009	A - 38	2
158889001	B - 25	4
158906001	B - 29	4
158907001	B - 29-1	4
158908001	B - 29-5	4
158909001	B - 30	4
158917001	C - 6-1	6
158920001	C - 15-3	6
158921001	C - 15-4	6
158922001	C - 15-6	6
158923001	C - 15-8	6
158924001	C - 15-9	6
158925001	C - 15-10	6
158926001	C - 17	6
158927001	C - 15-13	6
158929001	C - 25	6
158930001	C - 21	6
158931001	C - 23	6
158933001	C - 26	6
158935001	C - 34	6
158940001	C - 38	6
158946001	C - 41	6
158947001	C - 15-1	6
159150009	Y - 1-4	98
159189000	N - 36	66
159190001	N - 37	66
159191000	N - 38	66
159192000	N - 40	66
159193000	N - 41	66
159324001	M - 21	64
159426001	C - 32	6
159540001	R - 4	76
	Z2 - 11	112
159541001	R - 14	76
	Z2 - 12	112
159542101	R - 19	76

CODE	REF.NO.	PAGE
159561001	N - 14	66
159624001	B - 21-1	4
159625001	C - 39-2	6
159690001	A - 15	2
159744100	B - 27	4
159745100	M - 1	64
159805001	P - 18-6	70
	P - 4	70
159906001	C - 22	6
183378001	P - 16	70
183400009	C1 - 6	110
183514009	P - 18	70
183532001	M - 17	64
183702001	C - 1	6
183707001	C - 6	6
183809001	M - 24-2	64
183810001	M - 24-3	64
183811001	M - 24-4	64
215083001	Q - 1-3	74
	T - 52	90
	T - 92	90
	T - 94	90
525567000	T - 129	88
525664000	G - 128-60	22
	L - 59	62
	T - 128	88
	W - 26	96
525907000	A1 - 76	102
	G - 60	16
	H - 39	24
	T - 70	86
552851001	Q - 1-27-5	74
552907000	K - 1-1-6	30
	K - 2-1-6	36
	K - 3-1-6	42
	K - 4-1-6	48
	K - 5-1-6	54
552908000	T - 95	88
554482000	T - 10	86
	T - 131	88
602394001	T - 18	90

brother

ブラザー工業株式会社

〒467 名古屋市瑞穂区河岸一丁目1番1号
TEL (052) 824-2392代

BROTHER INDUSTRIES, LTD. NAGOYA, JAPAN

151-760
195760-001 ①
1992, 05

Printed in Japan/Gedruckt in Japan/Imprimé au Japon/Impreso en Japón