

T-8450B

パーツブック
PARTS BOOK

2本針本縫角縫ミシン

TWIN NEEDLE SPLIT NEEDLE BAR LOCK STITCHER

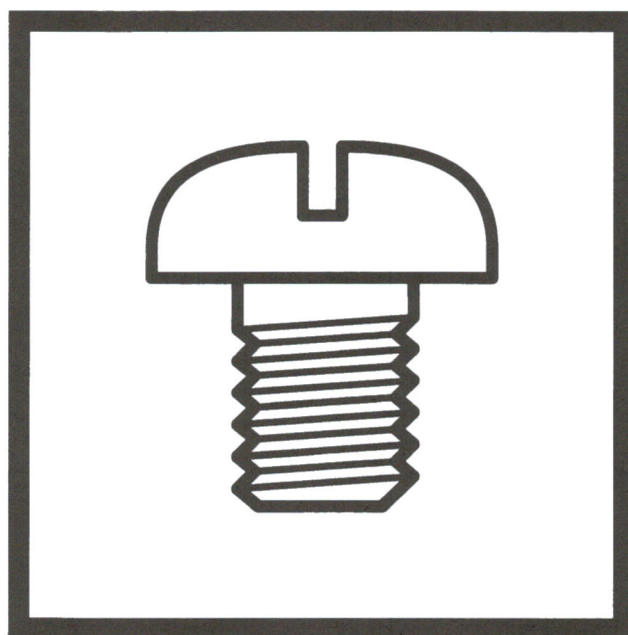

brother[®]

最新の部品情報は Parts Navigation でご覧いただけます。
The latest parts information, refer to the Parts Navigation.

<http://partsbook.brother.co.jp/jpn/>
<http://partsbook.brother.co.jp/eng/>

NEEDLE BAR LOCK STITCHER



brother

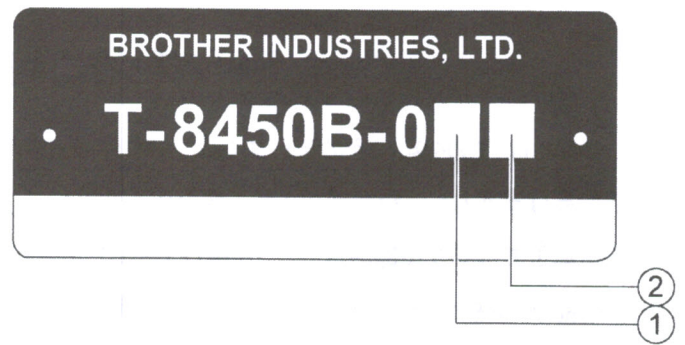

① — 0: 微量給油仕様 / Minimum lubrication type

② — 3: 中厚物 / Medium-weight materials
5: 厚物 / Heavy-weight materials

パーツブックご利用に際して

1. この本は、2004年 10月のデータに基づいて作成されたものです。
2. 部品は予告なしに設計変更される場合があります。
3. 組単位で補給する部品は、 破線で示してあります。
4. 部品コード欄が*となっている場合は、仕様別部品一覧表及びゲージ部品一覧表でお調べ下さい。
(38から43ページ)

目 次

A. 主体関係	1
B. 上軸関係	3
C. 針棒揺動関係	5
D. 針棒切替操作関係	9
E. 押え関係	11
F. 送り関係	13
G. 送り軸関係	15
J1. カマ関係	17
J2. カマ関係	21
H. ゲージ関係	21
K. 下軸関係	23
L. 給油潤滑関係	25
M. 糸通し関係	29
N. 糸巻関係	31
Z1. 付属品関係	33
Z2. 付属品関係	35
Wa. 警告ラベル	37
Sp. 仕様別部品一覧	38
Ga. ゲージ一覧	39
索引	44

Notes for using this parts book

1. This book was prepared based on information available in October 2004.
2. Parts are subject to changes in design without prior notice.
3. Parts supplied as complete assemblies are circled by a dotted line .
4. If the symbol * is found in the " Parts No." column, refer to the different parts lists, gauge parts list on page 38 - 43.

CONTENTS

A. Machine body	1
B. Upper shaft mechanism	3
C. Needle bar rocking mechanism	5
D. Needle bar flip-up mechanism	9
E. Presser foot mechanism	11
F. Feed mechanism	13
G. Feed shaft mechanism	15
J1. Rotary hook mechanism	17
J2. Rotary hook mechanism	21
H. Gauge parts	21
K. Lower shaft mechanism	23
L. Lubrication	25
M. Threading mechanism	29
N. Bobbin winder mechanism	31
Z1. Accessories	33
Z2. Accessories	35
Wa. Warning labels	37
Sp. Different parts list	38
Ga. Gauge parts list	39
Index	44

A. 主体関係 / Machine body

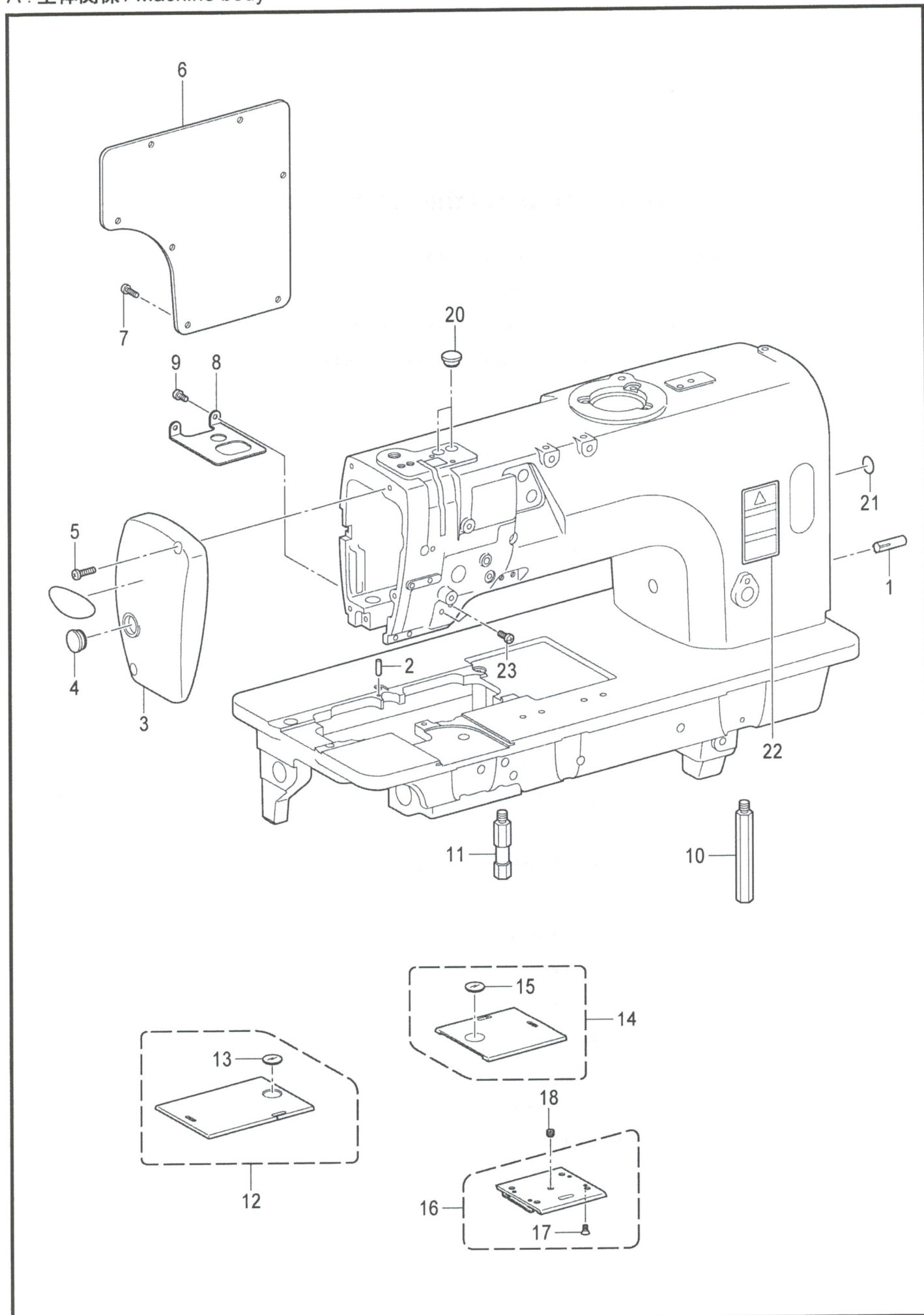

A. 主体関係 / Machine body

REF.NO	CODE	Q'TY	品名	NAME OF PARTS	RM
1	140063001	1	ミゾツキピン	DOWEL PIN	
2	SA3924001	1	ハライタイチキメピン	POSITIONING PIN	
3	SA4364001	1	メンイタ	FACE PLATE	
4	104449001	1	ゴムセン15.5	RUBBER CAP, 15.5	
5	062501416	2	ナベコ5X14	SCREW PAN M5X14	
6	SA2441001	1	ガワイタ	REAR COVER	
7	062501216	7	ナベコ5X12	SCREW PAN M5X12	
8	SA4370001	1	ダストプレート	DUST PROTECTOR	
9	062500616	2	ナベコ5X6	SCREW PAN M5X6	
10	SA2444001	1	キヤクチュウL	BED LEG,L	
11	SA2445001	1	キヤクチュウS	BED LEG,S	
12	SA2447001	1	スベリイタLAクミ	SLIDE PLATE, LA ASSY	
13	SA2479001	1	スベリイタマド	BOBBIN WINDOW	
14	SA2449001	1	スベリイタRクミ	SLIDE PLATE ASSY, R	
15	SA2479001	1	スベリイタマド	BOBBIN WINDOW	
16	S36663051	1	スベリイタFクミ	SLIDE PLATE F ASSY	
17	S34438051	4	サラネジ3.18X4	SCREW, FLAT SM3.18-40X4	
18	116010001	1	トメネジ5.16	SET SCREW, SM5.16-40X4	
20	SA2929001	2	ゴムセン12.5	RUBBER CAP, 12.5	
21	S37060001	1	ア-スマーク	LABEL, GROUNDING	
22	SA2040001	1	<中国向以外> ラベルチュウイ.ワエイ	<For Except China> LABEL, CAUTION JPN/ENG	
22	SA2041001	1	<中国向> ラベルチュウイ.チュウエイ	<For China only> LABEL, CAUTION CHN/ENG	
23	062500816	2	ナベコ5X8	SCREW PAN M5X8	

B. 上軸関係 / Upper shaft mechanism

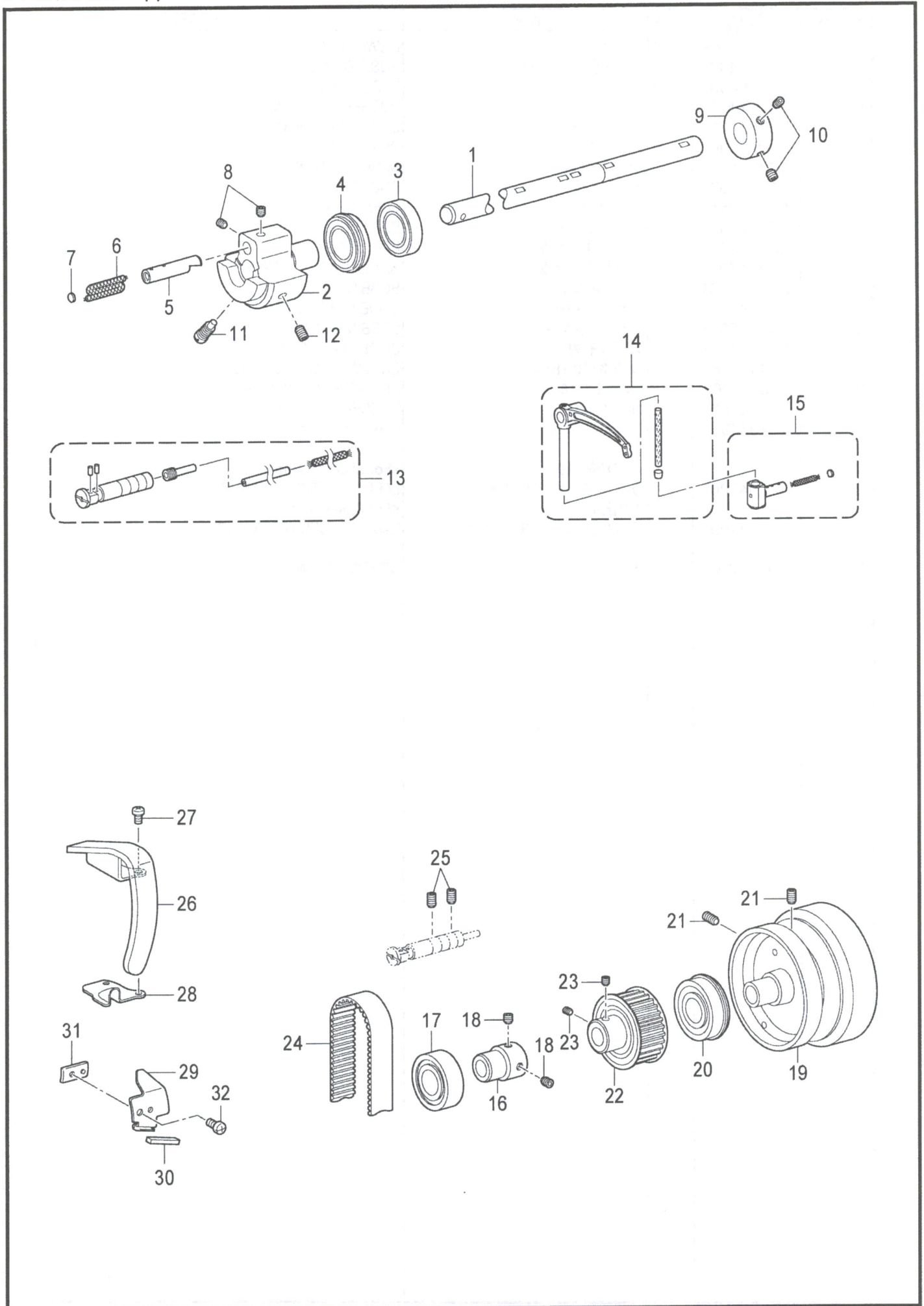

B. 上軸関係 / Upper shaft mechanism

REF.NO	CODE	Q'TY	品名	NAME OF PARTS	RM
1	SA4550001	1	ウワジクST	UPPER SHAFT, ST	
2	SA4373001	1	テンビンクランク	THREAD TAKE-UP CRANK	
3	S25234001	1	タマジクウケ6004ZZ	BALL BEARING, 6004ZZ	
4	S38707001	1	タマジクウケ6004ZZNR	BALL BEARING, 6004ZZNR	
5	S38398001	1	ハリボウクランクジク	CRANKSHAFT, N-BAR	
6	SA4335001	1	クミヒモ4X4	WICK,4X4(L=90)	
7	113014000	1	クミヒモフタ	PUSHER	
8	S25260001	2	アナヒラ6X5ホソメ	SET SCREW, SOCKET (FT) M6X5	
9	SA1120001	1	イトマキドウリン	BOBBIN WINDER DRIVING WHEEL	
10	S23651001	2	アナヒラ6X6ホソメ	SET SCREW, SOCKET (FT) M6X6	
11	S25235001	1	シメネジ8	SCREW, M8	
12	S25236001	1	アナヒラ6X10ホソメ	SET SCREW, SOCKET (FT) M6X10	
13	SA2861001	1	テンビンササエジクソウクミ	THREAD TAKE-UP S-SHAFT UNIT	
14	SA2936101	1	テンビンS5-Lクミ	THREAD TAKE-UP LEVER ASSY, S5-L	
15	S13160001	1	テンビンスベリコ2クミ	T-TAKE-UP SLIDE BLOCK ASSY, 2	
16	SA2748001	1	タマジクウケブツシュ	BALL BEARING BUSH	
17	076023800	1	Rタマジクウケ60/22ZZ	BALL BEARING RADIAL 60/22ZZ	
18	S23651001	2	アナヒラ6X6ホソメ	SET SCREW, SOCKET (FT) M6X6	
19	SA2750001	1	プーリ	PULLY	
20	158115001	1	タマジクウケ6204ZZNR	BALL BEARING, 6204ZZNR	
21	012061036	2	アナヒラ6X10	SET SCREW SOCKET (FT) M6X10	
22	SA2720101	1	タイミングプーリU STクミ	TIMING PULLEY ASSY, U ST	
23	SA4214001	2	アナトメネジ6X6ホソメ	SET SCREW, SOCKET (CP) M6X6	
24	SA2463001	1	タイミングベルト	TIMING BELT	
25	012061036	2	アナヒラ6X10	SET SCREW SOCKET (FT) M6X10	
26	SA2469001	1	テンビンカバー	THREAD TAKE-UP LEVER COVER	
27	062500816	2	ナベコ5X8	SCREW PAN M5X8	
28	SA4537001	1	ダストカバー	DUST COVER	
29	SA4376101	1	シヤハイバン	SHELTER PLATE	
30	SA3065001	1	フェルト	FELT	
31	SA3059001	1	シヤハイバンオサエ	HOLDER, SHELTER PLATE	
32	062500816	1	ナベコ5X8	SCREW PAN M5X8	

C. 針棒揺動関係 / Needle bar rocking mechanism

REF.NO	CODE	Q'TY	品名	NAME OF PARTS	RM
1	SA4377001	1	ハリボウヨウドウジクミ	NEEDLE BAR ROCKER SHAFT ASSY	
2	SA4378001	1	ハリボウダイクミ	NEEDLE BAR BASE ASSY	
3	SA2474101	1	カクコマスライダ	SLIDE BLOCK SLIDER	
4	018401036	2	アナボルト4X10	BOLT SOCKET M4X10	
5	SA4382001	1	ハリボウLクミ	NEEDLE BAR ASSY, L	
6	SA4385001	1	ハリボウRクミ	NEEDLE BAR ASSY, R	

7	SA4387001	1	必ず記号を確認後注文のこと ハリボウダキクミ <記号A>	Need check the "Mark" the above parts before ordering. NEEDLE BAR CLAMP ASSY <Mark A>	
7	SA4387002	1	ハリボウダキクミ <記号B>	NEEDLE BAR CLAMP ASSY <Mark B>	
7	SA4387003	1	ハリボウダキクミ <記号C>	NEEDLE BAR CLAMP ASSY <Mark C>	

8	149604001	2	ピン1.5X5.8	PIN, 1.5X5.8	
9	149605001	2	クラツチテコバネ	SPRING, CLUTCH LEVER	
10	149827001	1	ピン2X15.8	PIN, 2X15.8	
11	S34561001	1	クラツチトメL	CLUTCH STOPPER, L	
12	S34562001	1	クラツチトメR	CLUTCH STOPPER, R	
13	149608001	1	ピン2X17.8	PIN, 2X17.8	
14	112609001	2	スベリイタストツパバネ	SPRING	
15	SA4391001	1	バネササエ	SPRING HOLDER	
16	062260316	2	ナベコ26X3	SCREW PAN M2.6X3	
17	149610001	1	リリースピン	PIN	
18	149611101	1	リリースピンバネ	SPRING, RELEASE PIN	
19	SA4392001	1	リリースピンフタ	PIN COVER	
20	062260516	1	ナベコ26X5	SCREW PAN M2.6X5	
21	SA4389001	2	クラツチテコクミ	CLUTCH LEVER ASSY	
22	SA4395001	1	スベリコアンナイイタ	SLIDE BLOCK GUIDE PLATE	

23	S07575000	1	必ず記号を確認後注文のこと スベリコクミ <記号25>	Need check the "Mark" the above parts before ordering. SLIDE BLOCK ASSY, 25 <Mark 25>	
23	S07575001	1	スベリコクミ <記号30>	SLIDE BLOCK ASSY, 30 <Mark 30>	
23	S07575002	1	スベリコクミ <記号35>	SLIDE BLOCK ASSY, 35 <Mark 35>	
23	S07575003	1	スベリコクミ <記号40>	SLIDE BLOCK ASSY, 40 <Mark 40>	
23	S07575004	1	スベリコクミ <記号45>	SLIDE BLOCK ASSY, 45 <Mark 45>	
23	S07575005	1	スベリコクミ <記号50>	SLIDE BLOCK ASSY, 50 <Mark 50>	
23	S07575006	1	スベリコクミ <記号55>	SLIDE BLOCK ASSY, 55 <Mark 55>	
23	S07575007	1	スベリコクミ <記号60>	SLIDE BLOCK ASSY, 60 <Mark 60>	
23	S07575008	1	スベリコクミ <記号65>	SLIDE BLOCK ASSY, 65 <Mark 65>	
23	S07575009	1	スベリコクミ <記号70>	SLIDE BLOCK ASSY, 70 <Mark 70>	
23	S07575010	1	スベリコクミ <記号75>	SLIDE BLOCK ASSY, 75 <Mark 75>	
23	S07575011	1	スベリコクミ <記号80>	SLIDE BLOCK ASSY, 80 <Mark 80>	

24	SA4583001	2	ハリボウストツパー	STOPPER, N-BAR	
25	149622001	2	ハリボウストツパーバネ	SPRING, N-BAR STOPPER	
26	SA4396001	1	バネフタ	SPRING COVER	
27	060350616	1	バインド35X6	SCREW BIND M3.5X6	
28	SA4397001	2	ハリボウマワリトメ	ROTATE STOPPER, N-BAR	
29	SA4398001	2	シメネジ3.5	SCREW, SM3.5	
30	060350616	2	バインド35X6	SCREW BIND M3.5X6	
31	SA4399001	2	ザガネ	WASHER, PLANE	
32	062350816	2	ナベコ35X8	SCREW PAN M3.5X8	
33	112728001	1	クミヒモ	WICK, L=50	
34	SA4393001	1	ハリボウクランクロツド	CRANK ROD, N-BAR	
35	SA4394001	1	カクコマ	SLIDE BLOCK	
36	SA4401001	1	フェルトオサエD	FELT SUPPORT, D	
37	062350616	2	ナベコ35X6	SCREW PAN M3.5X6	
38	SA4400001	1	フェルト	FELT	
39	107155001	2	フェルト	FELT	
40	SA5155001	1	フェルトササエ	FELT SUPPORT	

C. 針棒搖動關係 / Needle bar rocking mechanism

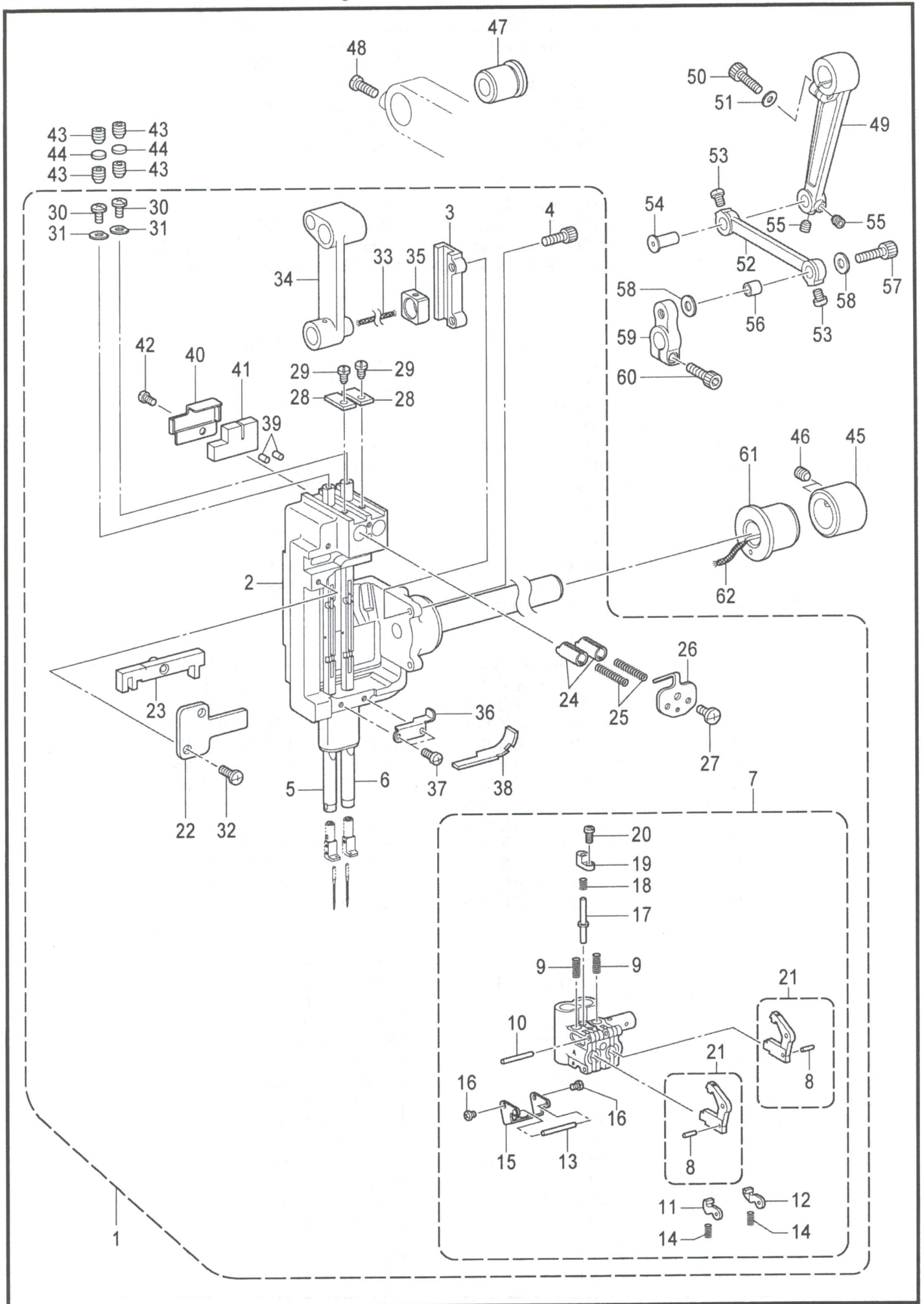

C. 針棒揺動関係 / Needle bar rocking mechanism

REF.NO	CODE	Q'TY	品名	NAME OF PARTS	RM
41	SA5237001	1	フェルト	FELT	
42	062350516	1	ナベコ35X5	SCREW PAN M3.5X5	
43	014080831	4	アナクボミ8X8	SET SCREW SOCKET (CP) M8X8	
44	154567000	2	カンザ5.3	SPACER, 5.3	
45	SA2485001	1	セットカラ-	SET SCREW COLLAR	
46	S25260001	2	アナヒラ6X5ホソメ	SET SCREW, SOCKET (FT) M6X5	
47	SA2486101	1	ヨウドウジクメタルR	BUSH, R	
48	062061616	1	ナベコ6X16	SCREW PAN M6X16	
49	SA2489001	1	ハリボウヨウドウレバー	NEEDLE BAR ROCKER LEVER ASSY	
50	018062032	1	アナボルト6X20	BOLT SOCKET M6X20	
51	118735002	1	ザガネ	WASHER	
52	SA2490101	1	ハリボウヨウドウリンク	ROCKER LINK, N-BAR	
53	S23460001	2	ナベコ6X5	SCREW, PAN M6X5	
54	SA4117001	1	ヨウドウリンクジクP	LINK SHAFT, N-BAR ROCKER P	
55	012060636	2	アナヒラ6X6	SET SCREW SOCKET (FT) M6X6	
56	SA4118001	1	ヨウドウリンクカラ-P	ZIGZAG LINK BUSH, P	
57	018062532	1	アナボルト6X25	BOLT SOCKET M6X25	
58	SA2493001	2	ザガネ	WASHER, PLAIN	
59	SA2494001	1	ハリボウヨウドウウデ	NEEDLE BAR ROCK ARM	
60	018062032	1	アナボルト6X20	BOLT SOCKET M6X20	
61	SA5332001	1	ヨウドウジクメタルL	BUSH, L	
62	S48204000	1	クミヒモ4X4	WICK, 4X4 L=150	

D. 針棒切換操作關係 / Needle bar flip-up mechanism

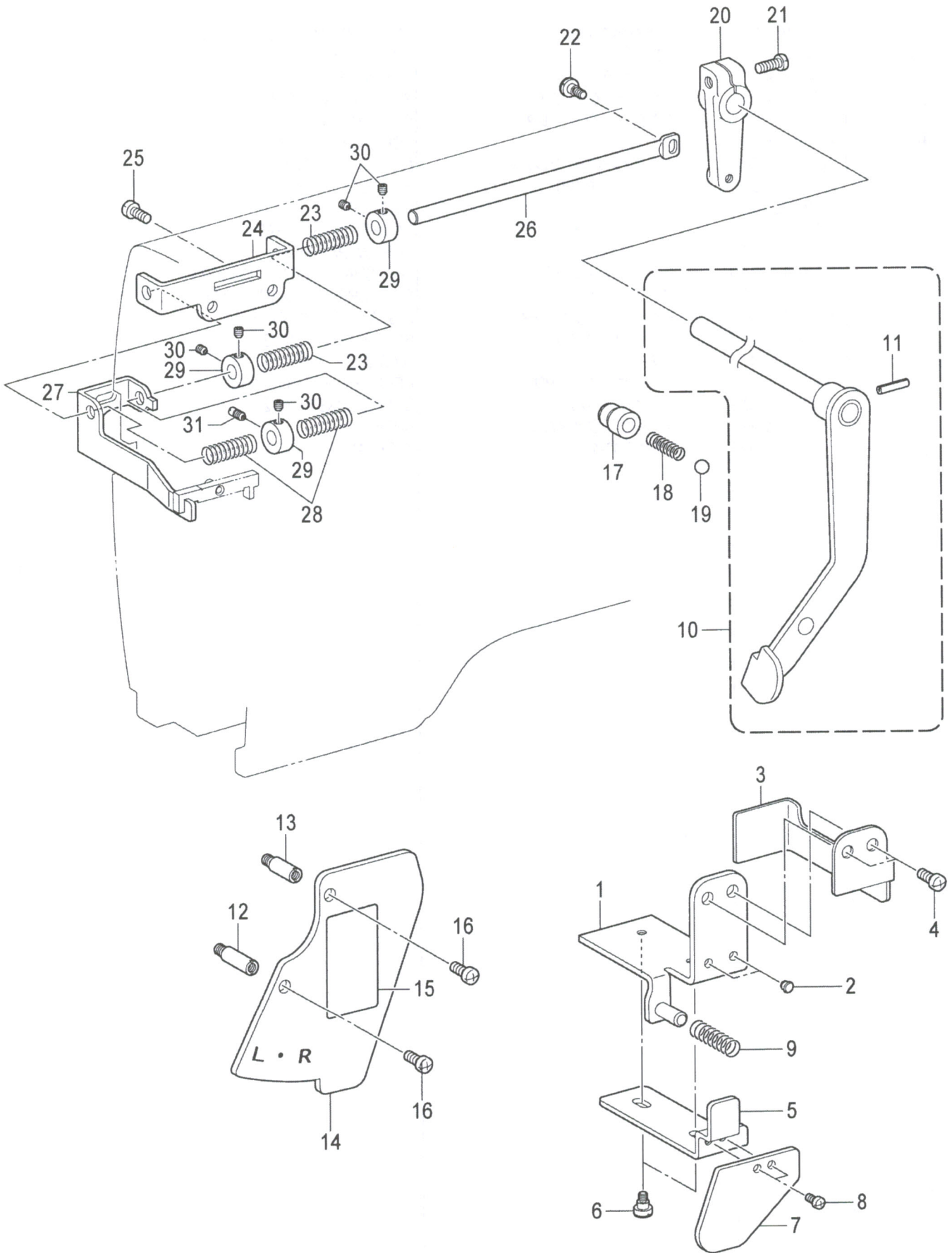

D. 針棒切替操作関係 / Needle bar flip-up mechanism

REF.NO	CODE	Q'TY	品名	NAME OF PARTS	RM
1	SA4402001	1	シジイタクミ	INDICATION PLATE ASSY	
2	104833001	2	ゴムセン4.3	RUBBER CAP, 4.3	
3	SA5336001	1	シジイタカバー	HOLDER PLATE COVER	
4	062501016	2	ナベコ5X10	SCREW PAN M5X10	
5	SA4404001	1	プツシユレバー	PUSH LEVER	
6	SA4441001	2	ダンネジM4	SHOULDER SCREW, M4	
7	SA4405001	1	プツシユレバーイタ	PLATE, PUSH LEVER	
8	062350516	2	ナベコ35X5	SCREW PAN M3.5X5	
9	SA5333001	1	プツシユレバーバネ	SPRING	
10	SA4406001	1	ストップレバージククミ	STOP LEVER SHAFT ASSY	
11	047301842	1	スプリングピンAW3	PIN SPRING ROLL AW3	
12	SA4408001	1	スタツドL	STUD, L	
13	SA4409001	1	スタツドS	STUD, S	
14	SA4411101	1	キリカエシジイタ	FLIP-UP HOLDER PLATE	
			<中国向以外>	<For Except China>	
15	S18964001	1	キリカエシジイタラベル.ワイ	LABEL	
			<中国向>	<For China only>	
15	SA4419001	1	キリカエシジイタラベル.チュウワイ	LABEL	
16	062500816	2	ナベコ5X8	SCREW PAN M5X8	
17	SA4412001	1	タマアンナイブツシユ	BALL GUIDE BUSH	
18	150820001	1	タマオシバネ	SPRING	
19	071063550	1	コウキユウ1/4	BEARING BALL, 1/4	
20	SA4413001	1	レバージクウデ	ARM, LEVER SHAFT	
21	062501416	1	ナベコ5X14	SCREW PAN M5X14	
22	S23773001	1	ダンネジM4	SHOULDER SCREW, M4	
23	SA4414001	2	レバージクウデバネ	SPRING	
24	SA4415001	1	スライドジクウケ	SLIDE SHAFT BRACKET	
25	062500816	2	ナベコ5X8	SCREW PAN M5X8	
26	S07588101	1	スライドジク	SLIDE SHAFT	
27	SA4416001	1	スライドジクウケイタ	SUPPORT PLATE, SLIDE SHAFT	
28	149863001	2	ジクウケイタバネ	SPRING, PLATE	
29	SA4417001	3	セツトカラー	SET SCREW COLLAR	
30	014400432	5	アナクボミ4X4	SET SCREW SOCKET (CP) M4X4	
31	SA4418001	1	アンナイネジ	GUIDE SCREW	

E. 押え関係 / Presser foot mechanism

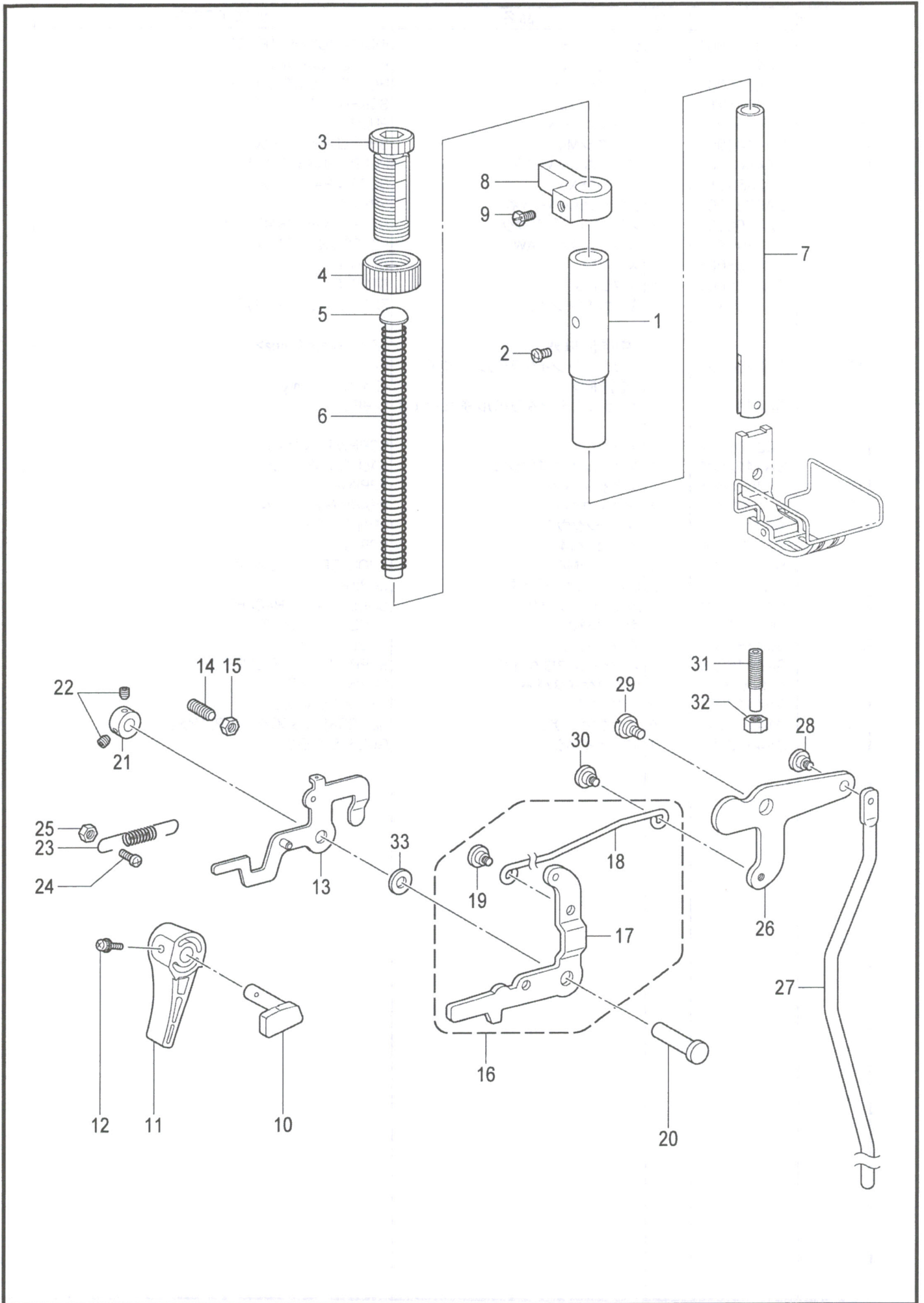

E. 押え関係 / Presser foot mechanism

REF.NO	CODE	Q'TY	品名	NAME OF PARTS	RM
1	SA2495001	1	オサエボウメタル	PRESSER BAR BUSH	
2	062500816	1	ナベコ5X8	SCREW PAN M5X8	
3	SA1174001	1	オサエチヨウセツネジM14	PRESSER ADJUSTING SCREW, M14	
4	SA1175001	1	チヨウセツネジナットM14	ADJUST SCREW NUT	
5	141208001	1	オサエバネアンナイ	SPRING GUIDE	
6	S07346101	1	オサエバネ	PRESSER BAR SPRING, -5	
7	SA2496001	1	オサエボウ	PRESSER BAR	
8	SA2498001	1	オサエボウダキ	GUIDE BRACKET, P-BAR	
9	S25289001	1	ボルト6	BOLT, (CP) M6X10	
10	SA2499001	1	オサエアゲクランク	PRESSER BAR LIFTING CRANK	
11	S31006001	1	オサエアゲテコ	LIFTING LEVER	
12	S39051001	1	ナベザクミ35X12	SCREW, PAN (S/P W) M3.5X12	
13	S07353001	1	イトユルメイタクミ	TENSION RELEASE PLATE ASSY	
14	012061832	1	アナヒラ6X18	SET SCREW, SOCKET (FT) M6X18	
15	021060306	1	3シュナット6	NUT 3 M6	
16	SA2500001	1	ヒザアゲレンカクミ	KNEE LIFTER C-ROD ASSY	
17	SA2501001	1	オサエアゲレバー	PRESSER BAR LIFTING LEVER	
18	SA2502001	1	ヒザアゲレンカン	KNEE LIFTER CONNECTING ROD	
19	SA1179001	1	ダンネジ5	SHOULDER SCREW, M5	
20	S07349001	1	オサエアゲレバージク	P-BAR LIFTING LEVER SHAFT	
21	SA2504001	1	セットカラー	SET SCREW COLLAR	
22	012500536	2	アナヒラ5X5	SET SCREW SOCKET (FT) M5X5	
23	S07355051	1	オサエアゲレバーバネ	SPRING, EXTENSION	
24	062501416	1	ナベコ5X14	SCREW PAN M5X14	
25	021500106	1	1シュナット5	NUT 1 M5	
26	SA2506001	1	ヒザアゲレバー	KNEE LIFTER LEVER	
27	SA2507001	1	ヒザアゲボウ	KNEE LIFTER BAR	
28	SA1179001	1	ダンネジ5	SHOULDER SCREW, M5	
29	SA2165001	1	ダンネジ6	SHOULDER SCREW, M6	
30	SA1179001	1	ダンネジ5	SHOULDER SCREW, M5	
31	SA4149001	1	チヨウセツネジ6	ADJUSTING SCREW, 6	
32	021060306	1	3シュナット6	NUT 3 M6	
33	S07350001	1	ザガネ	WASHER,PLAIN	

F. 送り関係 / Feed mechanism

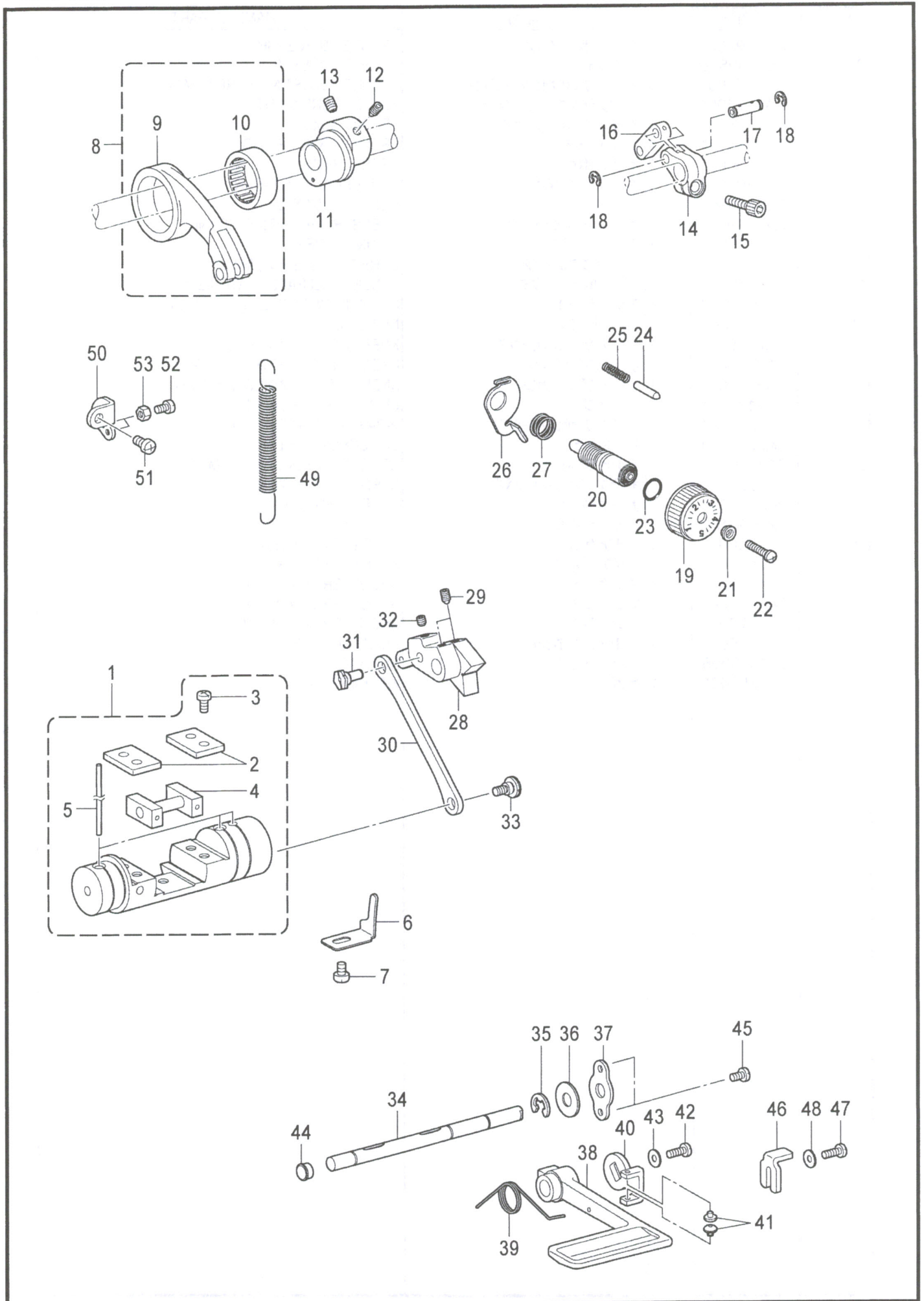

F. 送り関係 / Feed mechanism

REF.NO	CODE	Q'TY	品名	NAME OF PARTS	RM
1	SA2509001	1	キリカエキクミ	FEED REGULATOR ASSY	
2	SA2511001	2	カクコマアンナイタ	GUIDE PLATE	
3	062501016	4	ナベコ5X10	SCREW PAN M5X10	
4	SA2512001	1	キリカエキカクコマクミ	SLIDE BLOCK ASSY	
5	SA2515001	3	フェルト	FELT	
6	SA2516001	1	キリカエキトメ	STOPEER	
7	062060816	1	ナベコ6X8	SCREW PAN M6X8	
8	143611201	1	スイヘイオクリレンカンクミ	F-ROCKER CONNECTING ROD ASSY	
9	143612100	1	スイヘイオクリレンカン	FEED ROCKER CONNECTING ROD	
10	118954000	1	ニードルベアリング	NEEDLE BEARING	
11	SA2518001	1	スイヘイヘンシンリン5	LEVEL FEED ECCENTRIC WHEEL 5	
12	SA2585001	1	アナトガリ6X10ホソメ	SET SCREW, SOCKET (FT) M6	
13	S25236001	1	アナヒラ6X10ホソメ	SET SCREW, SOCKET (FT) M6X10	
14	SA2521001	1	スイヘイオクリウデ5	FEED ROCKER ARM 5	
15	018062032	1	アナボルト6X20	BOLT SOCKET M6X20	
16	143613051	1	スイヘイオクリウデリンク	LINK	
17	143616001	1	スイヘイオクリウデジク	SHAFT	
18	048060342	2	トメワE6	RETAINING RING E6	
19	S38427001	1	オクリメモリダイヤル	STITCH LENGTH DIAL, 5	
20	SA3056001	1	オクリチヨウセツネジ	FEED REGULATING STUD	
21	142746002	1	メモリイタオサエ	FEED REGULATING SUPPORTER	
22	129458102	1	シメネジ4.76	SCREW, SM4.76	
23	108549001	1	Oリング	O RING	
24	S50098101	1	メモリイチギメピン	POSITIONING PIN	
25	100328001	1	メモリイチキメピンバネ	NOTCH SPRING	
26	SA2523001	1	ダイヤルロックレバー	DIAL LOCK LEVER	
27	S39830101	1	ダイヤルロックレバーバネ	SPRING	
28	SA2525001	1	オクリチヨウセツキ5	FEED REGULATOR 5	
29	016061031	2	アナトガリ6X10	SET SCREW SOCKET (CN) M6X10	
30	SA2526001	1	キリカエキレンカン	CONNECTING ROD	
31	SA2527001	1	ヘンシンジク	ECCENTRIC SHAFT	
32	012060636	1	アナヒラ6X6	SET SCREW SOCKET (FT) M6X6	
33	SA2528101	1	ダンネジ6	SHOULDER SCREW, M6	
34	SA2529101	1	カエシヌイレバージクTR	SHAFT, R-LEVER TR	
35	048080342	1	トメワE8	RETAINING RING E8	
36	025100132	1	ヒラザガネショウ10	WASHER PLAIN S 10	
37	SA2530001	1	カンザ	SPACER	
38	S07374109	1	カエシヌイレバー	REVERSE STITCHING LEVER	
39	SA2531001	1	カエシヌイレバーオサエバネ	SPRING	
40	SA3067001	1	レバーガイド	LEVER GUIDE	
41	S48367000	2	レバーガイドゴム	RUBBER	
42	062501216	1	ナベコ5X12	SCREW PAN M5X12	
43	025050336	1	ヒラザガネダイ5	WASHER PLAIN L 5	
44	104821001	1	ゴムセン10.5	RUBBER CAP, 10.5	
45	062500816	2	ナベコ5X8	SCREW PAN M5X8	
46	SA2532001	1	ハンドルストツパ	STOPPER	
47	062501216	1	ナベコ5X12	SCREW PAN M5X12	
48	025050236	1	ヒラザガネチュウ5	WASHER PLAIN M 5	
49	S07376101	1	キリカエキバネ	FEED REGULATOR SPRING	
50	SA2533001	1	バネカケ	SPRING HOOK	
51	062060816	1	ナベコ6X8	SCREW PAN M6X8	
52	062501216	1	ナベコ5X12	SCREW PAN M5X12	
53	021500106	1	1シュナット5	NUT 1 M5	

G. 送り軸関係 / Feed shaft mechanism

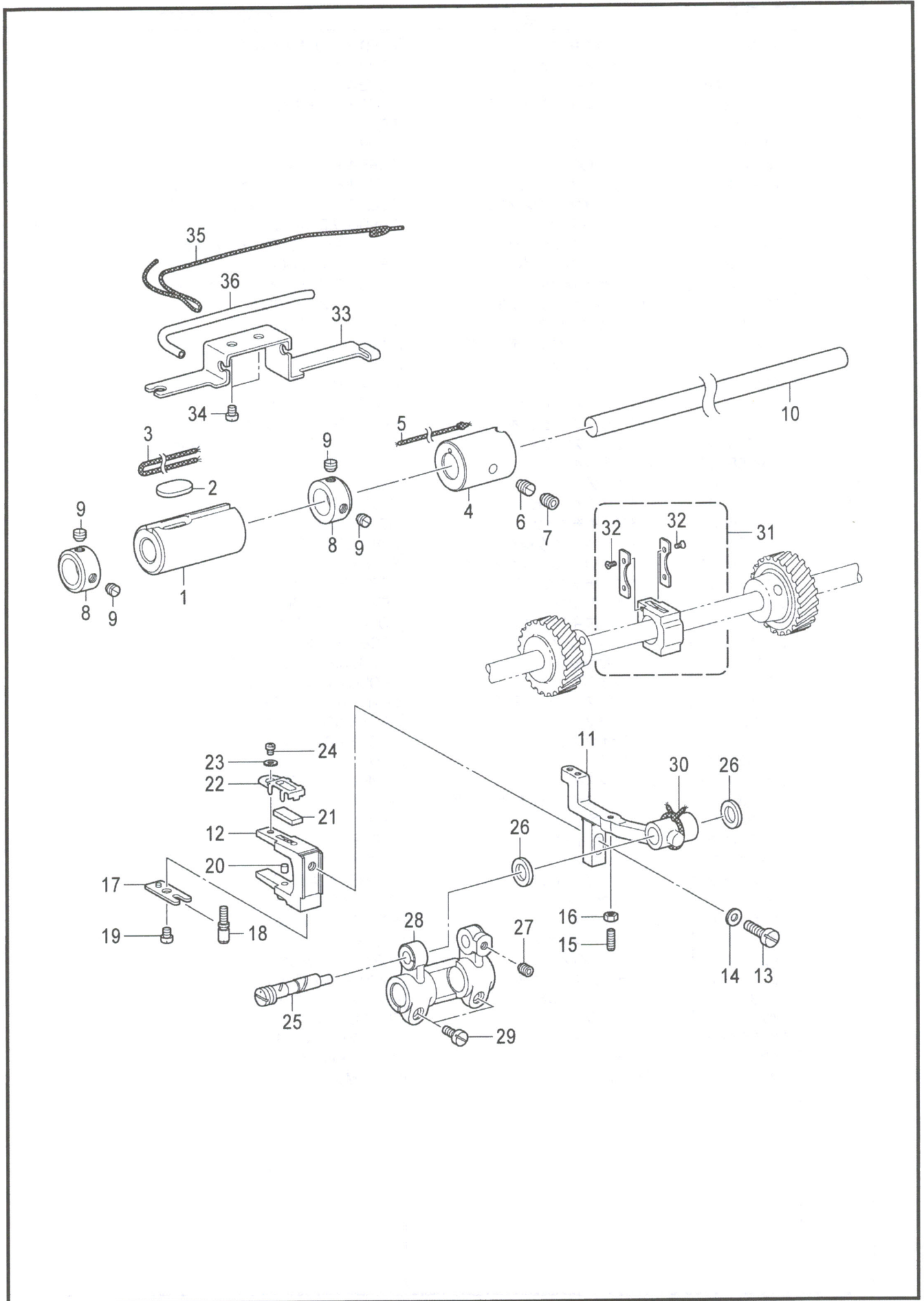

G. 送り軸関係 / Feed shaft mechanism

REF.NO	CODE	Q'TY	品名	NAME OF PARTS	RM
1	SA3855001	1	オクリジクメタルL	BUSH,L:F-ROCKER SHAFT	
2	SA3965001	1	フェルト	FELT	
3	SA4028001	1	クミヒモ4X4 L=220	WICK, 4X4 L=220	
4	SA2543001	1	オクリジクメタルR	FEED ROCKER SHAFT BUSH, R	
5	108802001	1	クミヒモ4X4	WICK, 4X4 L=250	
6	SA2544001	1	トメネジM6	SET SCREW M6	
7	012060636	1	アナヒラ6X6	SET SCREW SOCKET (FT) M6X6	
8	SA2546001	2	セットカラー	SET SCREW COLLAR	
9	S23651001	4	アナヒラ6X6ホソメ	SET SCREW, SOCKET (FT) M6X6	
10	SA3840001	1	スイヘイオクリジク	FEED ROCKER SHAFT	
11	SA3864001	1	オクリダイST	FEED BAR,ST	
12	SA3886001	1	オクリダイフタマタ	FEED BAR FORK	
13	SA2927001	1	シメネジM6X14	SCREW, M6X14	
14	025060132	1	ヒラザガネシヨウ6	WASHER PLAIN S 6	
15	SA2566001	1	トメネジ3.5	SET SCREW, M3.5	
16	021350106	1	1シュナット35	NUT 1 M3.5	
17	SA2553001	1	フタマタプレート	FORKED PLATE	
18	SA2554001	1	タカサチヨウセツネジ	ADJUSTING SCREW ,HIGHT	
19	062400616	1	ナベコ4X6	SCREW PAN M4X6	
20	SA3990001	1	フェルト	FELT	
21	SA3887001	1	フェルト	FELT	
22	SA3888001	1	フェルトオサエ	FELT HOLDER	
23	025030132	1	ヒラザガネシヨウ3	WASHER PLAIN S 3	
24	062300416	1	ナベコ3X4	SCREW PAN M3X4	
25	SA2550001	1	オクリダイトリツケジク	FEED BAR SHAFT	
26	SA2551001	2	スラストリング	THRUST RING	
27	012060636	1	アナヒラ6X6	SET SCREW SOCKET (FT) M6X6	
28	SA2555001	1	スイヘイオクリダイウデ	FEED ROCKER BASE ARM	
29	SA2928001	2	シメネジM5X12	SCREW, M5X12	
30	SA4538001	1	クミヒモ3X3 L=200	WICK, 3X3 L=200	
31	SA2806001	1	オクリダイカクコマクミ	FEED BAR SLIDE BLOCK ASSY	
32	W01519001	4	0サラコ3シユ2X4	SCREW, FLAT #0 M2X4	
33	SA4009001	1	クミヒモササエ	WICK SUPPORT	
34	062400616	2	ナベコ4X6	SCREW PAN M4X6	
35	SA2724001	1	クミヒモ	WICK, L=400	
36	SA4011001	1	ビニルチューブ L=100	OIL TUBE, L=100	

J1. かま関係 / Rotary hook mechanism

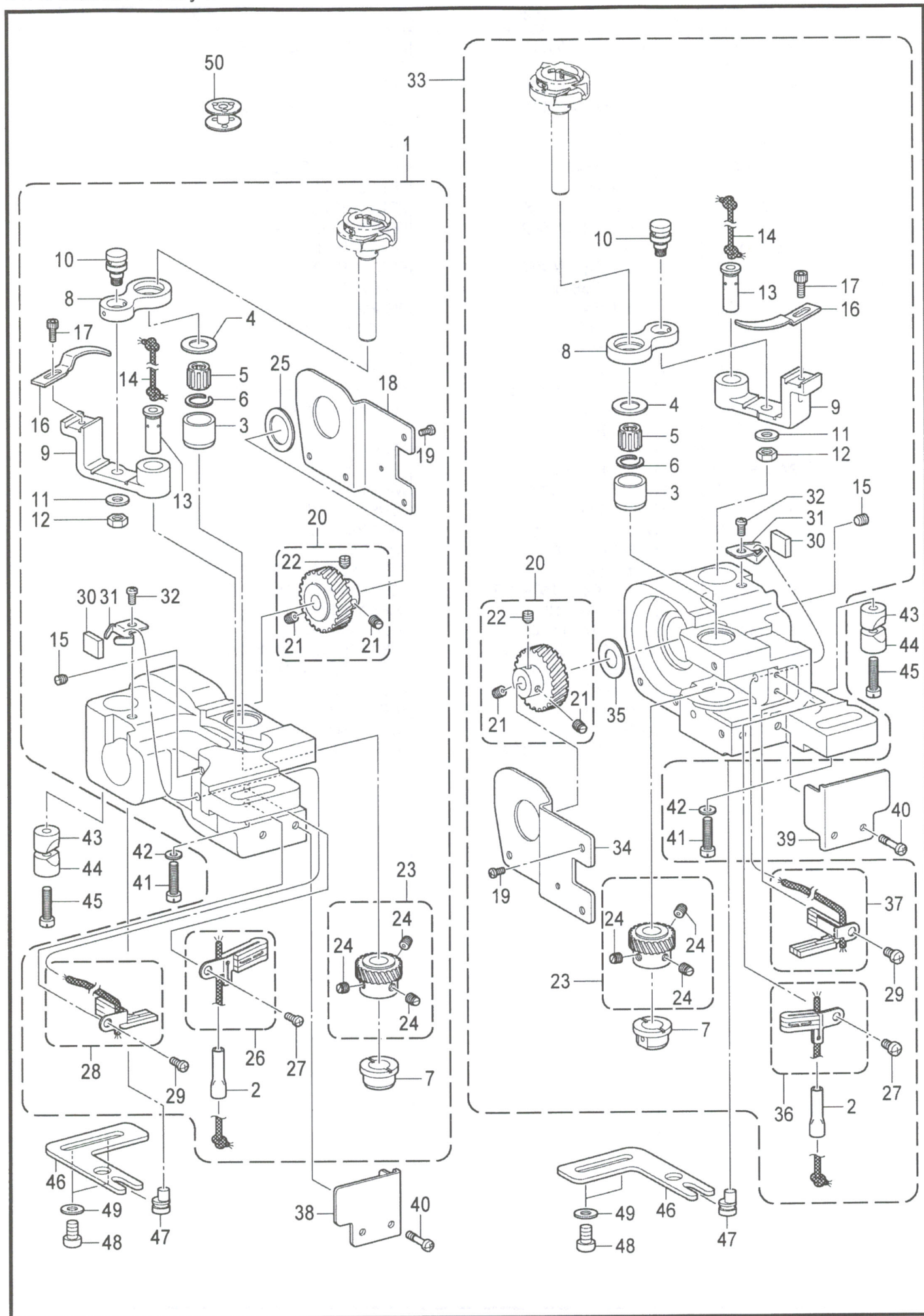

J1. カマ関係 / Rotary hook mechanism

REF.NO	CODE	QTY	品名	NAME OF PARTS	RM
1	SA4420101	1	カマドダイ845ST(L)クミ	ROTARY HOOK BASE ASSY,845ST(L)	
2	SA3961001	1	パイプ	PIPE	
3	SA4029001	1	カマジクメタルU	ROTARY HOOK SHAFT BUSH	
4	S09260001	1	スラストリングA <t=1.2>	THRUST RING, A :1.2MM <t=1.2>	
4	SA4038001	1	スラストリング <t=1.0>	THRUST RING <t=1.0>	
4	S09261001	1	スラストリングB <t=1.4>	THRUST RING, B :1.4MM <t=1.4>	
4	SA4444001	1	スラストリング0.8 <t=0.8>	THRUST RING 0.8MM <t=0.8>	
5	S07420000	1	ニードルベアリング	NEEDLE BEARING	
6	S07419001	1	ストツプリング	RETAINING RING	
7	SA2557001	1	カマジクメタルD	ROTARY HOOK SHAFT BUSH	
8	SA3856001	1	オープナーリンク	OPENER LINK	
9	SA3859001	1	オープナーレバー	OPENER LEVER	
10	SA2560001	1	オープナーリンクジク	SHAFT, O-LINK	
11	025710132	1	ヒラザガネシヨウ4.76	WASHER PLAIN S SM4.76	
12	021500316	1	3シュナット5	NUT 3 M5	
13	SA3889101	1	オープナーレバージク	O-LEVER SHAFT	
14	SA4026001	1	クミヒモ4X4 L=100	WICK, 4X4 L=100	
15	012500536	1	アナヒラ5X5	SET SCREW SOCKET (FT) M5X5	
16	S38212001	1	オープナー	OPENER	
17	154965001	1	アナボルト3.57X8	BOLT, SOCKET SM3.57X8	
18	SA2562101	1	カマドダイカバーL	ROTARY HOOK BASE COVER, L	
19	062300612	4	ナベコ3X6	SCREW PAN M3X6	
20	SA4549001	1	スパイラルギア ネジツキ	SPIRAL GEAR SCREW ASSY	
21	SA2574001	2	トメネジM6ホソメ	SET SCREW, (FT) M6	
22	SA2575001	1	トメネジM6ホソメ	SET SCREW, (FT) M6	
23	SA2576001	1	ピニオン ネジツキ	PINION GEAR SCREW ASSY	
24	SA2574001	3	トメネジM6ホソメ	SET SCREW, (FT) M6	
25	SA3054001	1	スラストザガネL	THRUST WASHER, L	
26	SA4042001	1	フェルトULクミ	FELT UL ASSY	
27	062400616	1	ナベコ4X6	SCREW PAN M4X6	
28	SA4044001	1	フェルトDLクミ	FELT DL ASSY	
29	062400616	1	ナベコ4X6	SCREW PAN M4X6	
30	SA4012001	1	フェルト	FELT	
31	SA3894001	1	フェルトオサエ	FELT SUPPORT	
32	062400616	1	ナベコ4X6	SCREW PAN M4X6	
<hr/>					
33	SA4421101	1	カマドダイ845ST(R)クミ	ROTARY HOOK BASE ASSY,845ST(R)	
2	SA3961001	1	パイプ	PIPE	
3	SA4029001	1	カマジクメタルU	ROTARY HOOK SHAFT BUSH	
4	S09260001	1	スラストリングA <t=1.2>	THRUST RING, A :1.2MM <t=1.2>	
4	SA4038001	1	スラストリング <t=1.0>	THRUST RING <t=1.0>	
4	S09261001	1	スラストリングB <t=1.4>	THRUST RING, B :1.4MM <t=1.4>	
4	SA4444001	1	スラストリング0.8 <t=0.8>	THRUST RING 0.8MM <t=0.8>	
5	S07420000	1	ニードルベアリング	NEEDLE BEARING	
6	S07419001	1	ストツプリング	RETAINING RING	
7	SA2557001	1	カマジクメタルD	ROTARY HOOK SHAFT BUSH	
8	SA3856001	1	オープナーリンク	OPENER LINK	
9	SA3859001	1	オープナーレバー	OPENER LEVER	
10	SA2560001	1	オープナーリンクジク	SHAFT, O-LINK	
11	025710132	1	ヒラザガネシヨウ4.76	WASHER PLAIN S SM4.76	
12	021500316	1	3シュナット5	NUT 3 M5	
13	SA3889101	1	オープナーレバージク	O-LEVER SHAFT	
14	SA4026001	1	クミヒモ4X4 L=100	WICK, 4X4 L=100	
15	012500536	1	アナヒラ5X5	SET SCREW SOCKET (FT) M5X5	
16	S38212001	1	オープナー	OPENER	
17	154965001	1	アナボルト3.57X8	BOLT, SOCKET SM3.57X8	
34	SA2563101	1	カマドダイカバーR	ROTARY HOOK BASE COVER, R	
19	062300612	4	ナベコ3X6	SCREW PAN M3X6	
20	SA4549001	1	スパイラルギア ネジツキ	SPIRAL GEAR SCREW ASSY	
21	SA2574001	2	トメネジM6ホソメ	SET SCREW, (FT) M6	
22	SA2575001	1	トメネジM6ホソメ	SET SCREW, (FT) M6	
23	SA2576001	1	ピニオン ネジツキ	PINION GEAR SCREW ASSY	

J1. かま関係 / Rotary hook mechanism

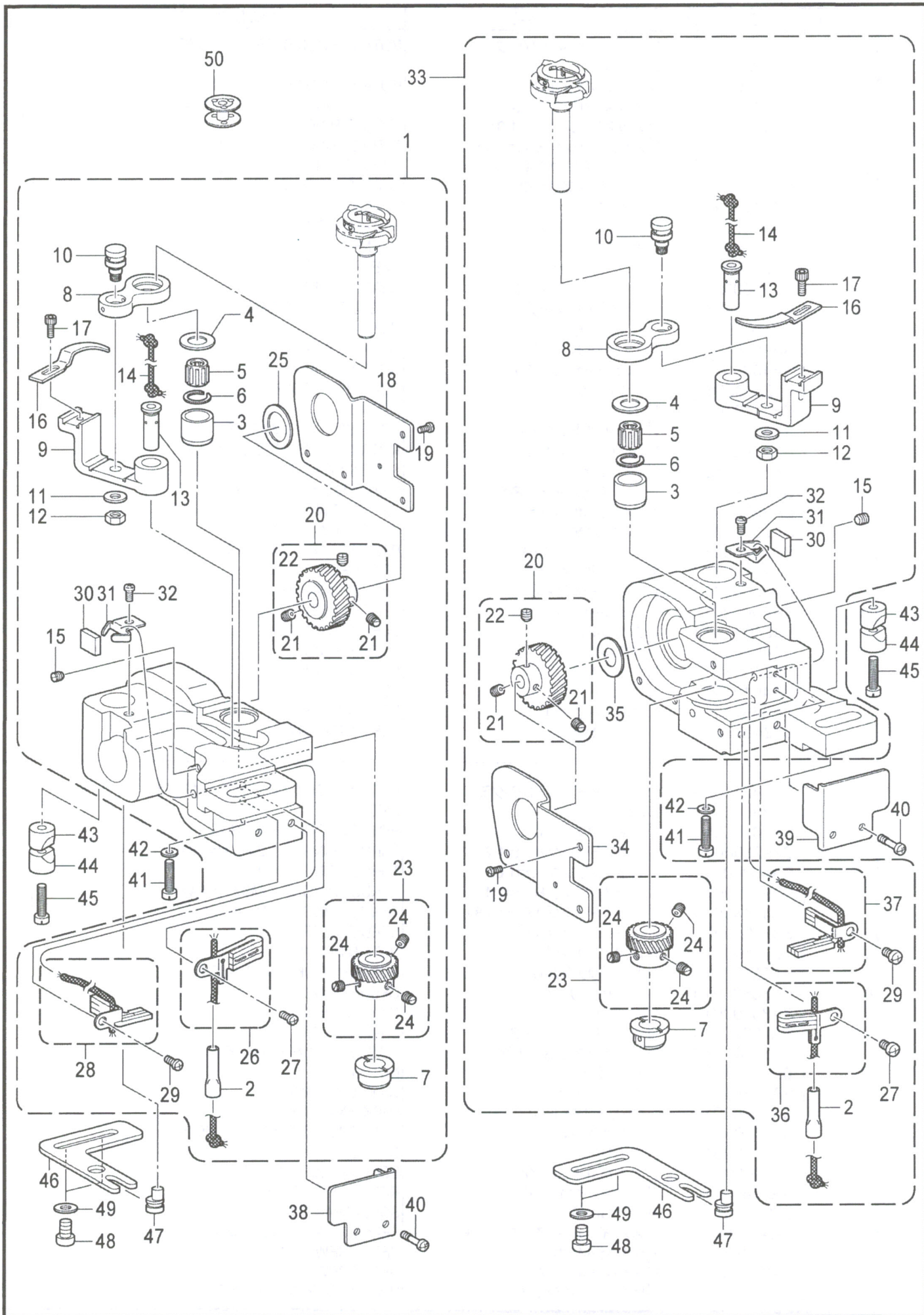

J1. カマ関係 / Rotary hook mechanism

REF.NO	CODE	Q'TY	品名	NAME OF PARTS	RM
24	SA2574001	3	トメネジM6ホソメ	SET SCREW, (FT) M6	
35	SA2579001	1	スラストザガネ	SPECER	
36	SA4043001	1	フェルトURクミ	FELT UR ASSY	
27	062400616	1	ナベコ4X6	SCREW PAN M4X6	
37	SA4045001	1	フェルトDRクミ	FELT DR ASSY	
29	062400616	1	ナベコ4X6	SCREW PAN M4X6	
30	SA4012001	1	フェルト	FELT	
31	SA3894001	1	フェルトオサエ	FELT SUPPORT	
32	062400616	1	ナベコ4X6	SCREW PAN M4X6	
38	SA3988001	1	カマダイカバー-FL	ROTARY HOOK BASE COVER, FL	
39	SA3916001	1	カマダイカバー-FR	ROTARY HOOK BASE COVER, FR	
40	SA2825001	4	シメネジM3X12	SCREW, M3X12	
41	SA2556001	2	シメネジM6X25	SCREW, M6X25	
42	115947001	2	ザガネ	WASHER, PLAIN 6.35	
43	SA2722001	2	ピンチスリーブA	PINCH SLEEVE A	
44	SA2565001	2	ピンチスリーブB	PINCH SLEEVE B	
45	SA2556001	2	シメネジM6X25	SCREW, M6X25	
46	SA2567001	2	ハリスキチヨウセツイタ	NEEDLE UPPER ADJUSTING PLATE	
47	SA2568001	2	ハリスキチヨウセツジク	NEEDLE UPPER POSITIONING SHAFT	
48	062061016	4	ナベコ6X10	SCREW PAN M6X10	
49	025060136	4	ヒラザガネショウ6	WASHER PLAIN S 6	
50	S01928151	2	ボビン	BOBBIN	

J2 . かま関係 / Rotary hook mechanism

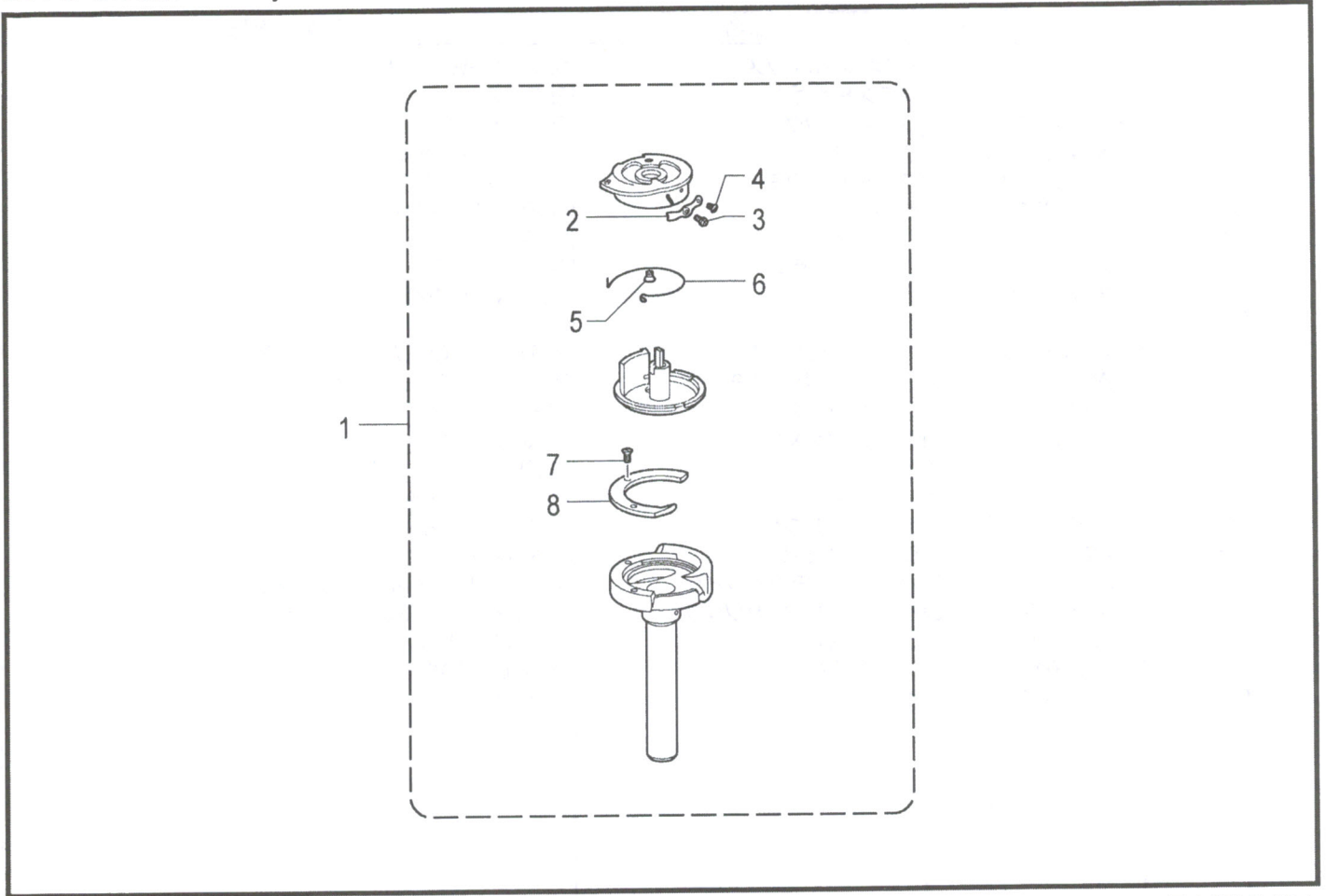

T-8450B-301

H . ゲージ関係 / Gauge parts

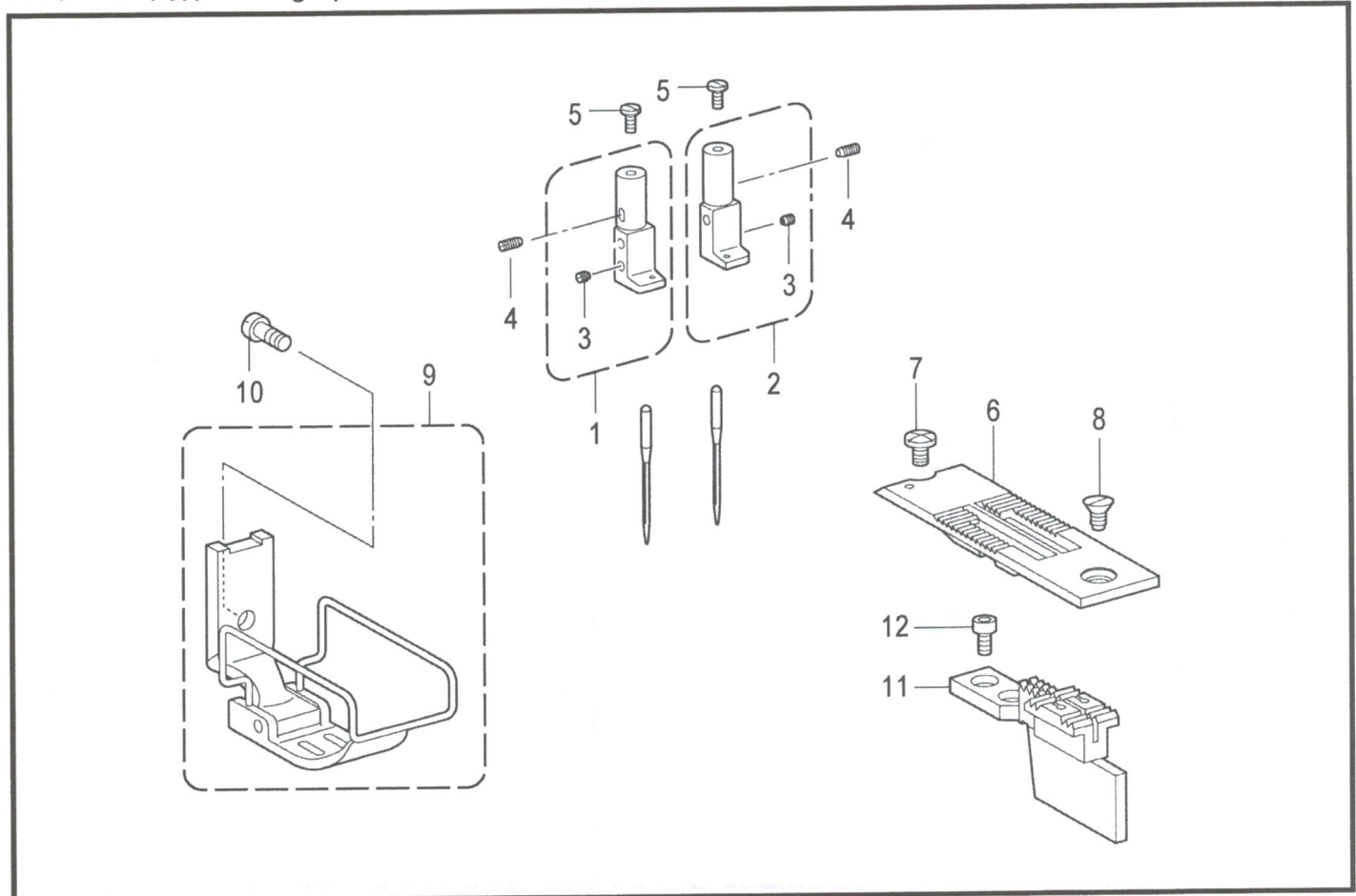

T-8450B-231

J2. カマ関係 / Rotary hook mechanism

REF.NO	CODE	Q'TY	品名	NAME OF PARTS	RM
1	*	1	カマハコクミ	ROTARY HOOK BOX ASSY	
2	151025001	1	チヨウシバネ	TENSION SPRING	
3	S01567001	1	チヨウシネジ	TENSION ADJUSTING SCREW	
4	S01568001	1	チヨウシバネトメネジ	SET SCREW	
5	151035001	1	タルミトリバネトメネジ	SET SCREW	
6	151034001	1	シタイトタルミトリバネ	TENSION SPRING	
7	151027001	2	ウチカマオサエトメネジ	SET SCREW	
8	S07746001	1	ウチカマオサエ	INNER ROTARY HOOK HOLDER	
<p>* については、仕様別部品一覧表(P.38)でお調べください。 As for symbol * look it up in the different parts list on page 38.</p>					

T-8450B-301

H. ゲージ関係 / Gauge parts

REF.NO	CODE	Q'TY	品名	NAME OF PARTS	RM
1	*	1	ハリダキLクミ	NEEDLE CLAMP ASSY,L	
2	*	1	ハリダキRクミ	NEEDLE CLAMP ASSY,R	
3	013660412	2	トメクボミ3.18-40X4	NEEDLE PLATE	
4	S13085001	2	トメネジ3.18	SET SCREW, SM3.18	
5	149831101	2	アタマツキトメネジ3.18	SET SCREW, SM3.18	
6	*	1	ハリイタ	NEEDLE PLATE	
7	S11244001	1	シメネジ4.37	SCREW, SM4.37	
8	100032004	1	サラネジ4.37	SCREW, FLAT SM4.37-40X8	
9	*	1	オサエクミ	PRESSER FOOT ASSY	
10	113050001	1	シメネジ3.57	SCREW, SM3.57	
11	*	1	オクリバ	FEED DOG	
12	S07494001	2	シメネジ3.18	SCREW, W/SOCKET SM3.18X7	
<p>* については、ゲージ部品一覧表(P.39-42)でお調べください。 As for symbol * look it up in the gauge parts list on page 39-42 .</p>					

T-8450B-231

K. 下軸関係 / Lower shaft mechanism

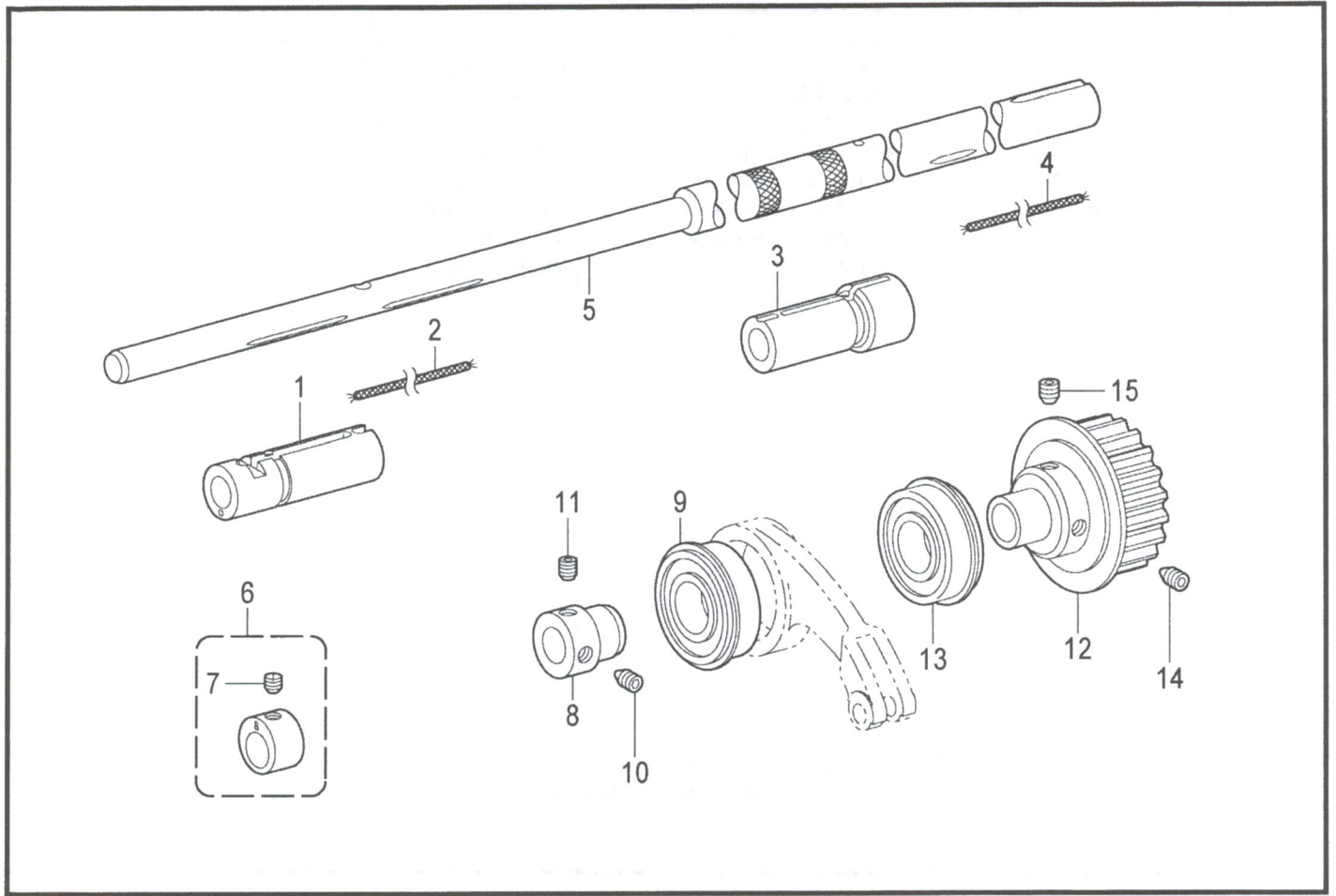

T-8450B-305

K. 下軸関係 / Lower shaft mechanism

REF.NO	CODE	QTY	品名	NAME OF PARTS	RM
1	SA3890001	1	カマドダイメタルL	ROTARY HOOK BASE BUSH, L	
2	SA4585001	1	フェルト	FELT	
3	SA3891001	1	カマドダイメタルR	ROTARY HOOK BASE BUSH, R	
4	SA4585001	1	フェルト	FELT	
5	SA2571001	1	シタジク	LOWER SHAFT	
6	SA2759001	1	ジヨウゲヘンシンリンSTクミ	F-LIFTING ECCENTRIC WHEEL ASSY	
7	SA2575001	1	トメネジM6ホソメ	SET SCREW, (FT) M6	
8	SA2584001	1	タマジクウケブツシュ	BALL BEARING BUSH	
9	072600480	1	Tタマジクウケ6004ZZ	BALL BEARING, THRUST 6004ZZ	
10	SA2585001	1	アナトガリ6X10ホソメ	SET SCREW, SOCKET (FT) M6	
11	S25236001	1	アナヒラ6X10ホソメ	SET SCREW, SOCKET (FT) M6X10	
12	SA2587101	1	タイミングプーリDクミ	TIMING PULLEY ASSY, D	
13	158115001	1	タマジクウケ6204ZZNR	BALL BEARING, 6204ZZNR	
14	SA2585001	1	アナトガリ6X10ホソメ	SET SCREW, SOCKET (FT) M6	
15	SA4213001	1	アナトメネジ6X10ホソメ	SET SCREW, SOCKET (CP) M6X10	

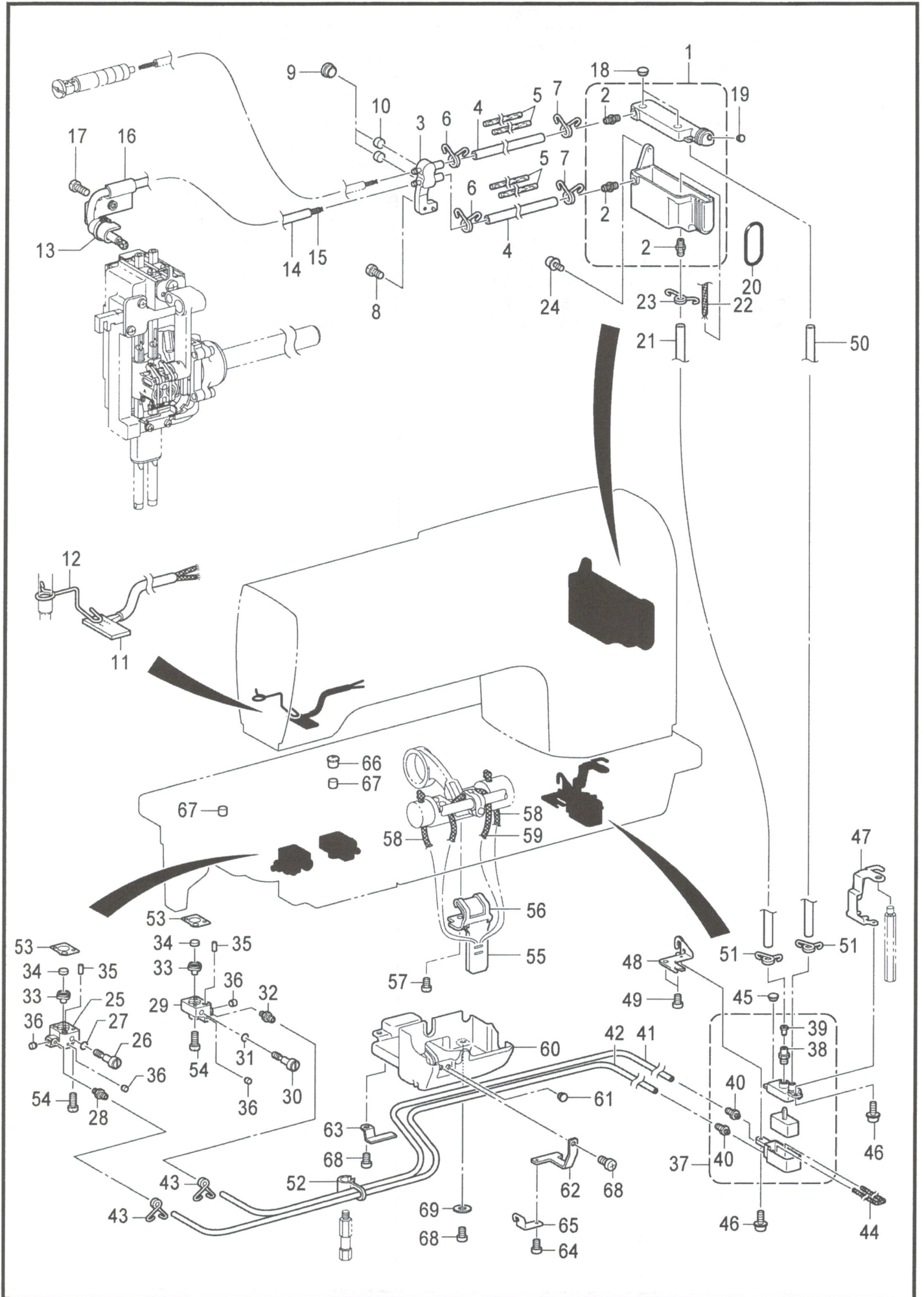

L. 給油潤滑関係 / Lubrication

REF.NO	CODE	QTY	品名	NAME OF PARTS	RM
1	SA2814201	1	オイルタンククミ	OIL TANK ASSY	
2	SA3040001	3	オイルクチ8.6	OIL FEEDING PIPE, 8.6	
3	SA3946001	1	キユウユタ-ミナル	OIL TERMINAL	
4	SA2956001	2	ビニルチューブ	OIL TUBE, L=135	
5	SA2957001	4	フェルト	FELT	
6	SA3055101	2	チューブストツパー	TUBE CLIP	
7	SA3055101	2	チューブストツパー	TUBE CLIP	
8	062500816	1	ナベコ5X8	SCREW PAN M5X8	
9	SA2929001	2	ゴムセン12.5	RUBBER CAP, 12.5	
10	S38266000	2	カマジクフェルト	ROTARY HOOK SHAFT FELT	
11	SA5224001	1	フェルトクミ	FELT ASSY	
12	SA4033101	1	フェルトオサエ	FELT SUPPORT	
13	228475000	1	ケツソクバンド1.9X80	FASTENING BAND, 1.9X80	
14	S49623000	1	ビニルチューブ	OIL TUBE, L=280	
15	S48190000	1	クミヒモ4X4	WICK, 4X4 L=380	
16	SA5154001	1	キユウユササエ	OIL SUPPORT	
17	062501016	1	ナベコ5X10	SCREW PAN M5X10	
18	SA2929001	2	ゴムセン12.5	RUBBER CAP, 12.5	
19	104450101	1	ゴムセン8	RUBBER CAP, 8	
20	081038070	1	OリングP38	O RING P38	
21	SA2723001	1	ビニルチューブ	OIL TUBE, L=210	
22	SA2724001	1	クミヒモ	WICK, L=400	
23	SA3055101	1	チューブストツパー	TUBE CLIP	
24	0A5501006	2	+ナベザクミ5X10DB	SCREW PAN (S/P WASHER) M5X10	
25	SA3896001	1	キユウユブロックL	OIL BLOCK,L	
26	SA2599001	1	オイルチヨウセツネジ	OIL ADJUSTING SCREW	
27	081004070	1	OリングP4	O RING P4	
28	SA3147001	1	オイルクチ2.5	OIL FEEDING PIPE 2.5	
29	SA3898001	1	キユウユブロックR	OIL BLOCK,R	
30	SA2599001	1	オイルチヨウセツネジ	OIL ADJUSTING SCREW	
31	081004070	1	OリングP4	O RING P4	
32	SA3147001	1	オイルクチ2.5	OIL FEEDING PIPE 2.5	
33	SA3061001	2	ゴムパツキン	RUBBER PACKING	
34	SA2727101	2	カマジクフェルト	ROTARY HOOK SHAFT FELT	
35	S05246000	2	フェルト	FELT	
36	142274101	4	ゴムセン4.2	RUBBER CAP, 4.2	
37	SA3037001	1	サブタンククミ	SUB-TANK ASSY	
38	SA3040001	1	オイルクチ	OIL FEEDING PIPE	
39	SA3060001	1	バルブパツキン	VALVE PACKING	
40	SA3147001	2	オイルクチ2.5	OIL FEEDING PIPE 2.5	
41	SA2596001	1	ビニルチューブ	OIL TUBE, L=400	
42	SA2597001	1	ビニルチューブ	OIL TUBE, L=500	
43	S07876101	2	チューブストツパー	TUBE CLIP	
44	SA2598101	1	クミヒモ	WICK, L=1250	
45	104450101	1	ゴムセン8	RUBBER CAP, 8	
46	0A4400806	2	+ナベザクミ4X8DA	SCREW PAN (S/P WASHER) M4X8	
47	SA3045101	1	サブタンクトリツケイタA	SUB-TANK SETTING PLATE, A	
48	SA3046001	1	サブタンクトリツケイタB	SUB-TANK SETTING PLATE, B	
49	062060816	2	ナベコ6X8	SCREW PAN M6X8	
50	SA3044001	1	ビニルチューブ	OIL TUBE, L=242	
51	SA3055101	2	チューブストツパー	TUBE CLIP	
52	SA3047001	1	チューブササエ	TUBE SUPPORT	
53	SA3923001	2	カマドダイDパツキン	ROTARY HOOK BASE D PACKING	
54	062401616	4	ナベコ4X16	SCREW PAN M4X16	
55	SA2604001	1	キリカエキフェルト	FEED REGULATOR FELT	
56	SA2605001	1	フェルトオサエイタ	FELT SUPPORT	
57	062500616	1	ナベコ5X6	SCREW PAN M5X6	
58	108802001	2	クミヒモ4X4	WICK, 4X4 L=250	
59	108801001	1	クミヒモ4X4	WICK, 4X4 L=350	
60	SA2606101	1	オイルカバー	OIL COVER	
61	104450101	1	ゴムセン8	RUBBER CAP, 8	
62	SA3048101	1	チューブオサエA	TUBE SUPPORT, A	
63	SA3049001	1	チューブオサエB	TUBE SUPPORT, B	

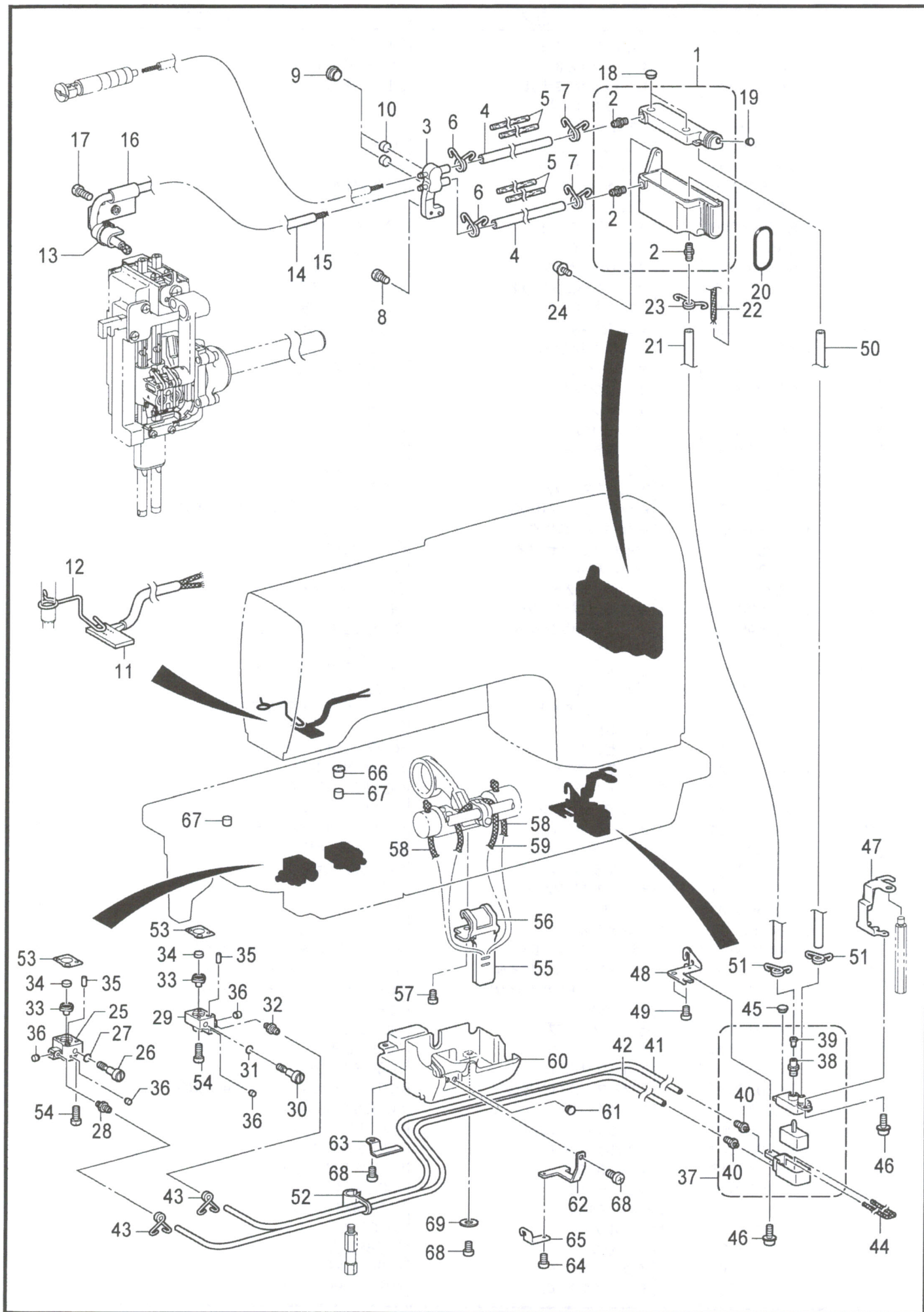

L. 給油潤滑関係 / Lubrication

REF.NO	CODE	Q'TY	品名	NAME OF PARTS	RM
64	062400616	1	ナベコ4X6	SCREW PAN M4X6	
65	SA4014001	1	チューブガイド	TUBE GUIDE	
66	140890009	1	オイルカツプ	OIL CAP	
67	112753001	2	フェルト	FELT	
68	062061016	3	ナベコ6X10	SCREW PAN M6X10	
69	025060236	1	ヒラザガネチュウ6	WASHER PLAIN M 6	

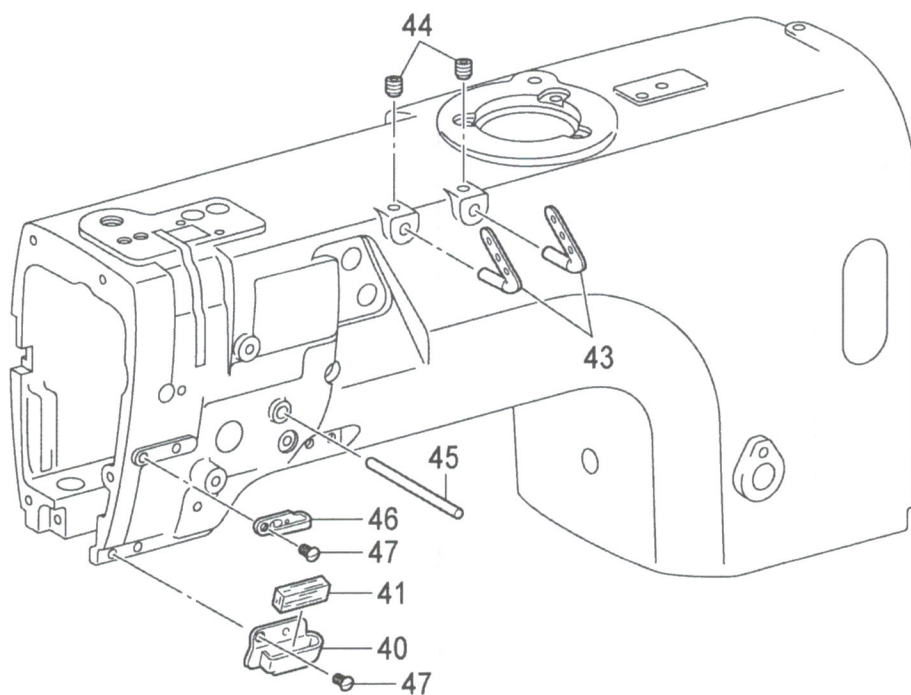
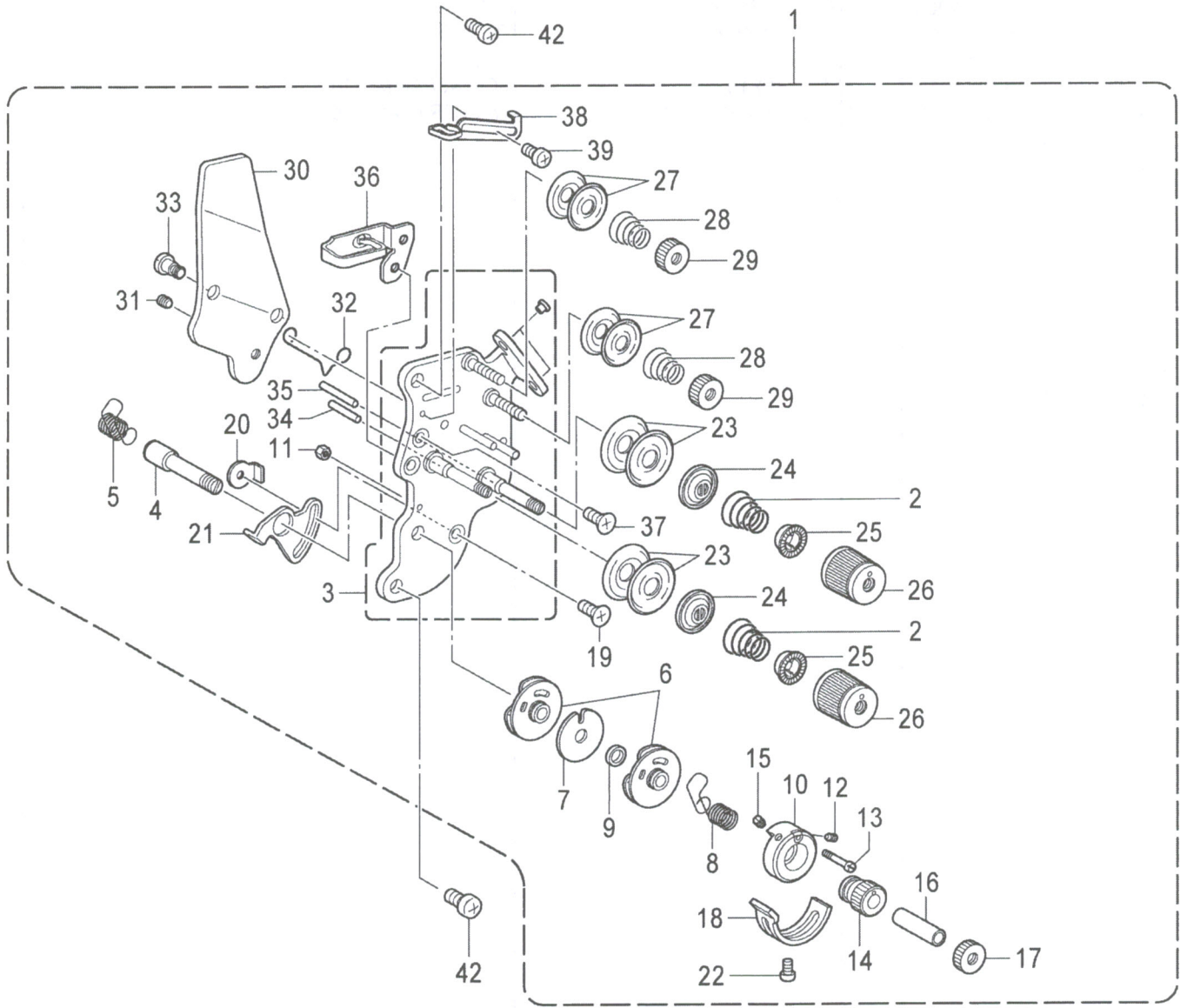

M. 糸通し関係 / Threading mechanism

REF.NO	CODE	Q'TY	品名	NAME OF PARTS	RM
1	SA3417001	1	<-□□3用> ウワイトチヨウシクミ-3	<For "-□□3"> UPPER THREAD TENSION ASSY, -3	
2	SA3415001	2	イトチヨウシバネL	TENSION SPRING, L	
1	SA2607001	1	<-□□5用> ウワイトチヨウシクミ-5	<For "-□□5"> UPPER THREAD TENSION ASSY, -5	
2	SA3416001	2	イトチヨウシバネLL	TENSION SPRING, LL	
3	SA4212001	1	イトチヨウシダイクミ	TENSION PLATE ASSY	
4	SA2613001	1	チヨウシジク	TENSION STUD	
5	SA2614001	1	イトトリバネL	THREAD TAKE-UP SPRING, L	
6	SA2615001	2	イトトリバネアンナイクミ	GUIDE ASSY, T/TAKE-UP SPRING	
7	SA2619001	1	スペーサー	SPACER	
8	SA2623001	1	イトトリバネR	THREAD TAKE-UP SPRING, R	
9	SA2620001	1	カラー	COLLAR	
10	SA2621001	1	ストツパウケ	STOPPER SUPPORT	
11	021300106	1	1シュナット3	NUT 1 M3	
12	SA2626001	1	トメネジ3.5	SET SCREW, (CP) M3.5	
13	SA2624001	1	バネアンナイトメネジ	SPRING GUIDE SET SCREW	
14	SA2625001	1	チヨウセツツマミ	ADJUSTING THUMB	
15	SA2626001	1	トメネジ3.5	SET SCREW, (CP) M3.5	
16	SA2627001	1	カラー	COLLAR	
17	SA2628001	1	イトチヨウシナツト	TENSION NUT	
18	SA2629001	1	イトトリバネストツパ	STOPPER	
19	061350616	1	サラコ35X6	SCREW FLAT M3.5X6	
20	SA2824001	1	マワリドメナツトM3.5	NUT, WHIRL-STOP M3.5	
21	SA2630001	1	イトトリバネストツパ	STOPPER	
22	062350512	1	ナベコ35X5	SCREW PAN M3.5X5	
23	145446001	4	イトチヨウシサラ	DISC, TENSION	
24	159805001	2	イトチヨウシサラオサエ	TENSION DISC PRESSER	
25	S20681000	2	チヨウシバネウエザガネ	WASHER	
26	S20682105	2	イトチヨウシナツト	TENSION NUT	
27	144504001	4	イトアンナイサラ	THREAD GUIDE DISC	
28	154560001	2	プレテンションバネA	PRE-TENSION SPRING, A	
29	155510001	2	イトチヨウシナツト	TENSION NUT	
30	SA2632001	1	イトユルメイタ	TENSION RELEASE PLATE	
31	012500536	1	アナヒラ5X5	SET SCREW SOCKET (FT) M5X5	
32	S38274001	1	イトユルメバネ	T-RELEASE SPRING	
33	SA2633001	2	ダンネジ3.5	SHOULDER SCREW, M3.5	
34	SA4506001	1	イトユルメピンL	TENSION RELEASE PIN, L	
35	SA4507001	1	イトユルメピンR	TENSION RELEASE PIN, R	
36	SA2634001	1	ア-ムイトアンナイU	THREAD GUIDE, U :ARM	
37	061350616	2	サラコ35X6	SCREW FLAT M3.5X6	
38	SA2635001	1	イトリヨウチヨウセイ	THREAD QUANTITY ADJUST	
39	062300616	1	ナベコ3X6	SCREW PAN M3X6	
40	SA2639001	1	ア-ムイトアンナイD	THREAD GUIDE, D :ARM	
41	114941001	1	ア-ムイトアンナイフェルト	FELT	
42	062500816	2	ナベコ5X8	SCREW PAN M5X8	
43	SA2636001	2	ミツメイトカケ	THREAD RETAINER	
44	012060636	2	アナヒラ6X6	SET SCREW SOCKET (FT) M6X6	
45	SA2637001	1	イトユルメジク	BAR, TENSION RELEASE	
46	SA2638001	1	ア-ムイトアンナイM	THREAD GUIDE, M :ARM	
47	SA2640001	2	サラネジ5X8	SCREW, FLAT M5X8	

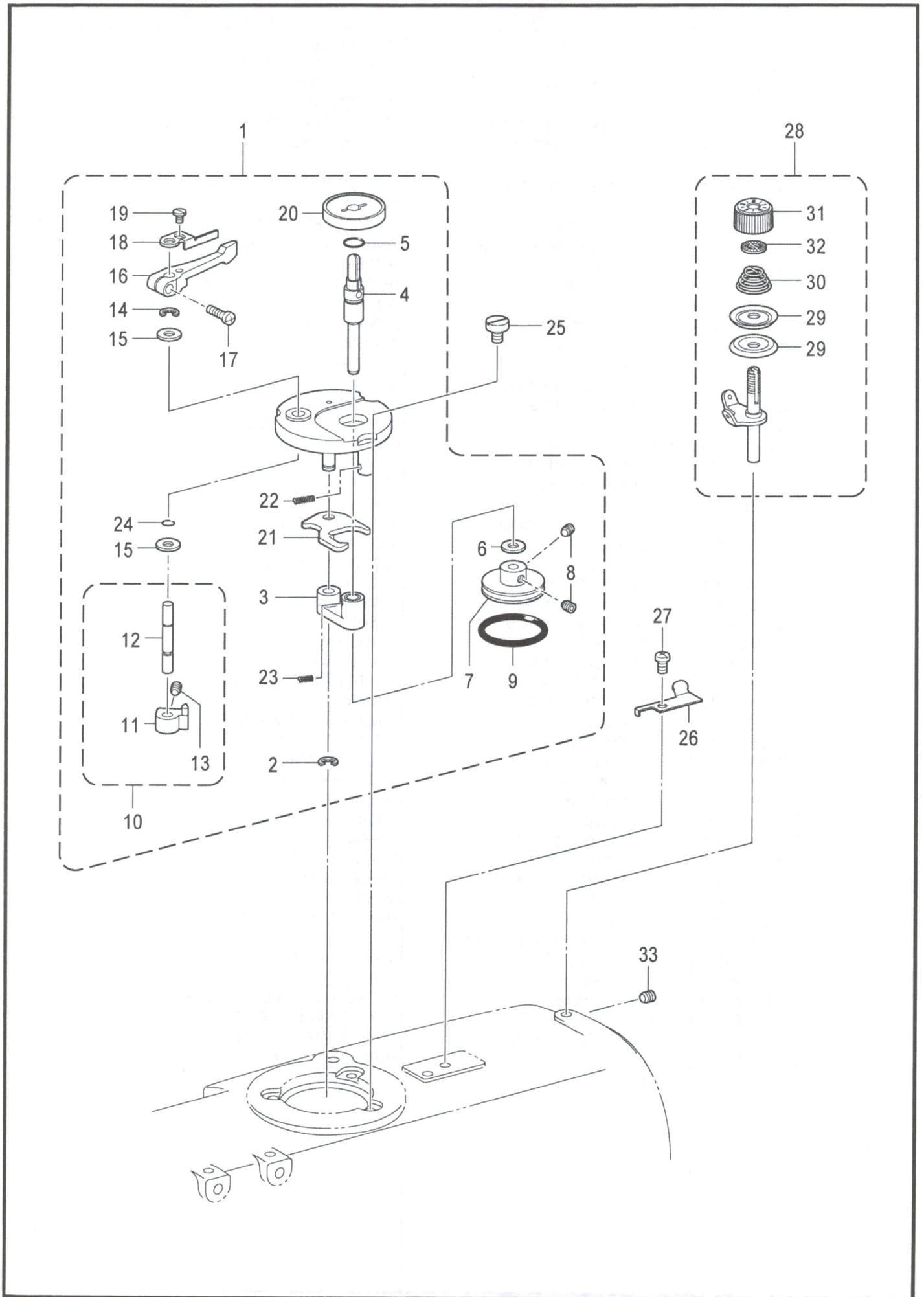

N. 糸巻関係 / Bobbin winder mechanism

REF.NO	CODE	Q'TY	品名	NAME OF PARTS	RM
1	SA1971101	1	イトマキユニット	BOBBIN WINDER UNIT	
2	048040342	1	トメワE4	RETAINING RING E4	
3	SA1975001	1	イトマキジクウケクミ	B-WINDER SHAFT SUPPORT ASSY	
4	SA1978001	1	イトマキジク	BOBBIN WINDER SHAFT	
5	081009070	1	OリングP9	O RING P9	
6	025060136	1	ヒラザガネショウ6	WASHER PLAIN S 6	
7	SA1980001	1	イトマキクルマ	BOBBIN WINDER WHEEL	
8	012500536	2	アナヒラ5X5	SET SCREW SOCKET (FT) M5X5	
9	S25789000	1	ゴムワ29	RUBBER RING, 29	
10	SA1981101	1	ボビンオサエカムクミ	BOBBIN PRESSER CAM ASSY	
11	SA1982101	1	ボビンオサエカム	BOBBIN PRESSER CAM	
12	SA1983001	1	イトマキウデジク	BOBBIN WINDER ARM SHAFT	
13	012500536	1	アナヒラ5X5	SET SCREW SOCKET (FT) M5X5	
14	048040342	1	トメワE4	RETAINING RING E4	
15	025060136	2	ヒラザガネショウ6	WASHER PLAIN S 6	
16	SA1984001	1	ボビンオサエウデ	BOBBIN PRESSER ARM	
17	062401216	1	ナベコ4X12	SCREW PAN M4X12	
18	SA1985001	1	ボビンオサエ	BOBBIN PRESSER	
19	S23418002	1	シメネジ4X5	SCREW, M4X5	
20	SA1988001	1	ボビンウケ	BOBBIN SUPPORT	
21	SA1989001	1	イトマキレバー	BOBBIN WINDER LEVER	
22	SA1990101	1	モドシバネ	SPRING	
23	SA1991001	1	イトマキダイバネ	BOBBIN WINDER BASE SPRING	
24	SA2190001	1	OリングSS5	O RING, SS5	
25	SA1992101	3	イトマキコティネジ	BOBBIN WINDER FIXED SCREW	
26	SA1360001	1	メス	KNIFE	
27	062500616	1	ナベコ5X6	SCREW PAN M5X6	
28	SA1994001	1	イトマキチヨウシクミ	BOBBIN WINDER TENSION ASSY	
29	145446001	2	イトチヨウシサラ	DISC, TENSION	
30	100401021	1	イトチヨウシバネ	TENSION SPRING	
31	S31032001	1	イトチヨウシナツト	TENSION NUT	
32	S12441001	1	チヨウシバネウエザガネ	WASHER	
33	012500536	1	アナヒラ5X5	SET SCREW SOCKET (FT) M5X5	

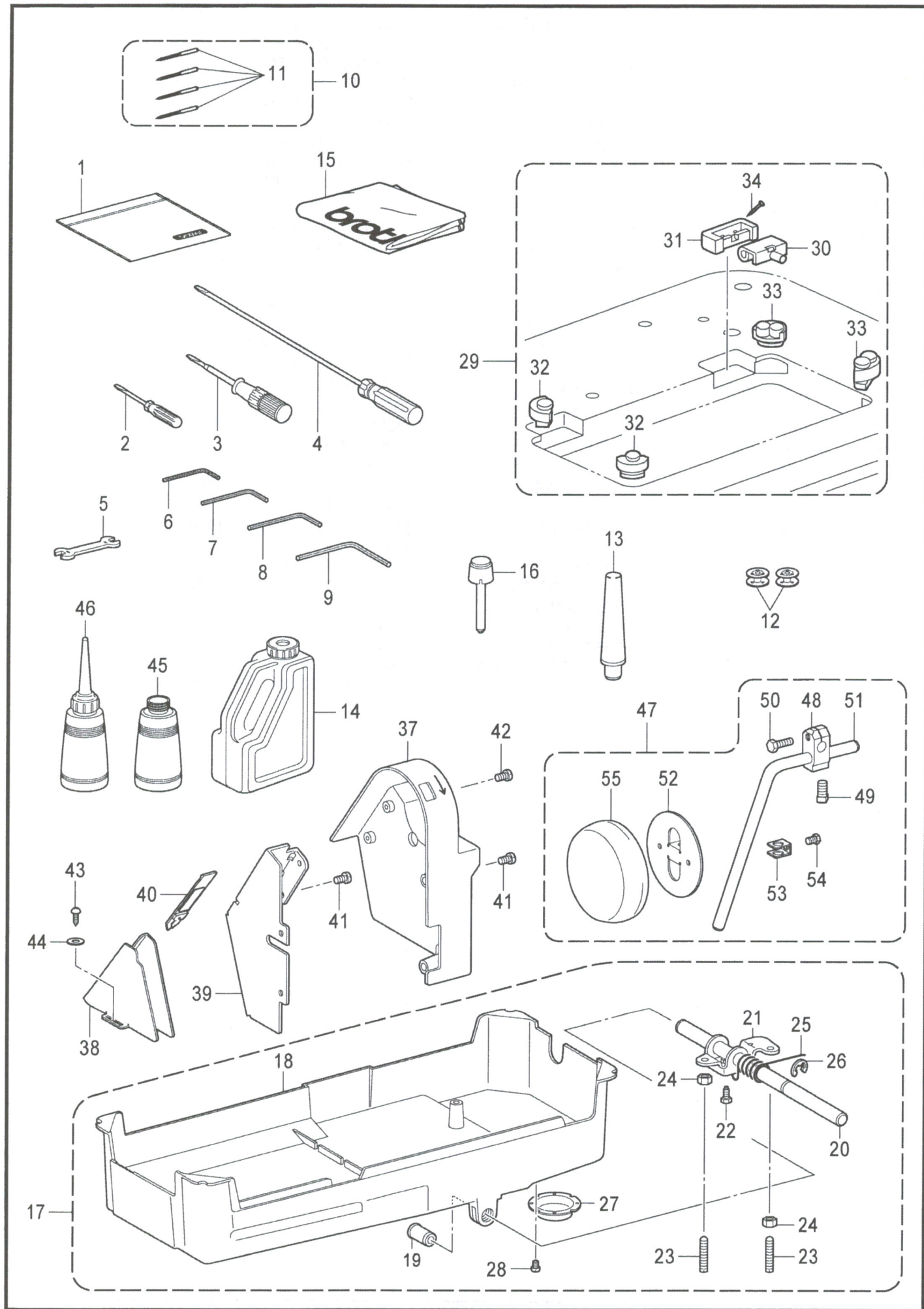

Z1. 付属品関係 / Accessories

REF.NO	CODE	Q'TY	品名	NAME OF PARTS	RM
1	122991001	1	フゾクヒンポリフクロ	ACCESSORY BAG	
2	142443001	1	ネジマワシ1.9X52	SCREW-DRIVER, 1.9X52	
3	118837001	1	ネジマワシ3.4X70	SCREW-DRIVER, 3.4X70	
4	S17774001	1	ネジマワシ4.7X250	SCREW-DRIVER, 4.7X250	
5	100887001	1	スパナ8X9	WRENCH, 8X9	
6	142002001	1	6カクボウスパナ2	HEXAGONAL WRENCH, 2	
7	154125001	1	6カクボウスパナ2.5	HEXAGONAL WRENCH, 2.5	
8	142721001	1	6カクボウスパナ3	HEXAGONAL WRENCH, 3	
9	149570001	1	6カクボウスパナ5 <-□□3用>	HEXAGONAL WRENCH, 5 <For "-□□3">	
10	SA1752014	1	107415ハリ4コイリクミ	NEEDLE 4PIECE ASSY, 107415	
11	107415014	4	ミシンハリDPX5 <-□□5用>	NEEDLE, DPX5 <For "--□□5">	
10	SA1752022	1	107415ハリ4コイリクミ	NEEDLE 4PIECE ASSY, 107415	
11	107415022	4	ミシンハリDPX5	NEEDLE, DPX5	
12	S01928151	2	ボビン	BOBBIN	
13	100477009	1	マクラ	HEAD REST	
14	S55663001	1	オイルタンククミ	OIL TANK ASSY	
15	144226001	1	トウブカバー	HEAD COVER	
16	145573000	1	ヒザアゲオンボウ	KNEE LIFTER COMPLYING BAR	
17	SA2691101	1	アブラウケクミ	OIL PAN ASSY	
18	SA2692101	1	アブラウケ	OIL PAN	
19	149578000	2	ヨコジクブツシュ	BUSH	
20	SA2582001	1	ヒザアゲヨコジク	KNEE LIFTER SHAFT	
21	SA2590001	1	ヒザアゲ	KNEE LIFTER	
22	S25344001	1	ボルト6	BOLT, M6	
23	S25475101	2	トメネジ6	SET SCREW, M6X19	
24	021060306	2	3シュナット6	NUT 3 M6	
25	S15889001	1	ヒザアゲネジリバネ	TWIST SPRING	
26	146293001	1	トメワE10	RETAINING RING, E10	
27	153230101	1	オイルニガシグチ	DRAIN	
28	S23418002	2	シメネジ4X5	SCREW, M4X5	
29	SA1969001	1	ラバーヒンジクミ	RUBBER HINGE ASSY	
30	143882001	2	トウブヒンジ	HEAD HINGE	
31	143910009	2	トウブヒンジウケゴム	RUBBER CUSHION	
32	SA1962001	2	トウブシキゴム	HEAD CUSHION	
33	SA1963001	2	トウブシキゴム	HEAD CUSHION	
34	109714000	4	クギ	NAIL	
37	SA2768101	1	ベルトカバー-U	BELT COVER, U	
38	SA2769001	1	ベルトカバー-D	BELT COVER, D	
39	SA2770101	1	ベルトカバー-ブラケット	BELT COVER BRACKET	
40	S37263001	1	ベルトカバー-DフタL	BELT COVER D LID, L	
41	062500816	4	ナベコ5X8	SCREW PAN M5X8	
42	062500816	2	ナベコ5X8	SCREW PAN M5X8	
43	100666002	2	マルモクネジ5.5X20	WOOD SCREW, ROUND M5.5X20	
44	025750132	2	ヒラザガネショウ5.56	WASHER PLAIN S SM5.56	
45	114486002	1	ポリオイラータイ	OILER	
46	114483002	1	ポリオイラークミ	OILER ASSY	
47	S38300001	1	ヒザアテクミ	KNEE LIFTER ASSY	
48	146039001	1	ヒザアテツギテ	KNEE LIFTER BRACKET	
49	100463001	1	4カクボルト7.94	BOLT, SQUARE SM7.94	
50	017762013	1	ボルト5.95-28X20	BOLT, SM5.95-28X20	
51	S38278001	1	ヒザアゲタテジク	KNEE LIFTER BAR	
52	S34756001	1	ヒザアテ	KNEE LIFTER PLATE	
53	114967001	1	ヒザアテストップ	KNEE LIFTER PLATE STOPPER	
54	110087001	1	ボルト5.95	BOLT, SM5.95-28X8	
55	S31885001	1	ヒザアテカバー	KNEE LIFTER PLATE COVER	

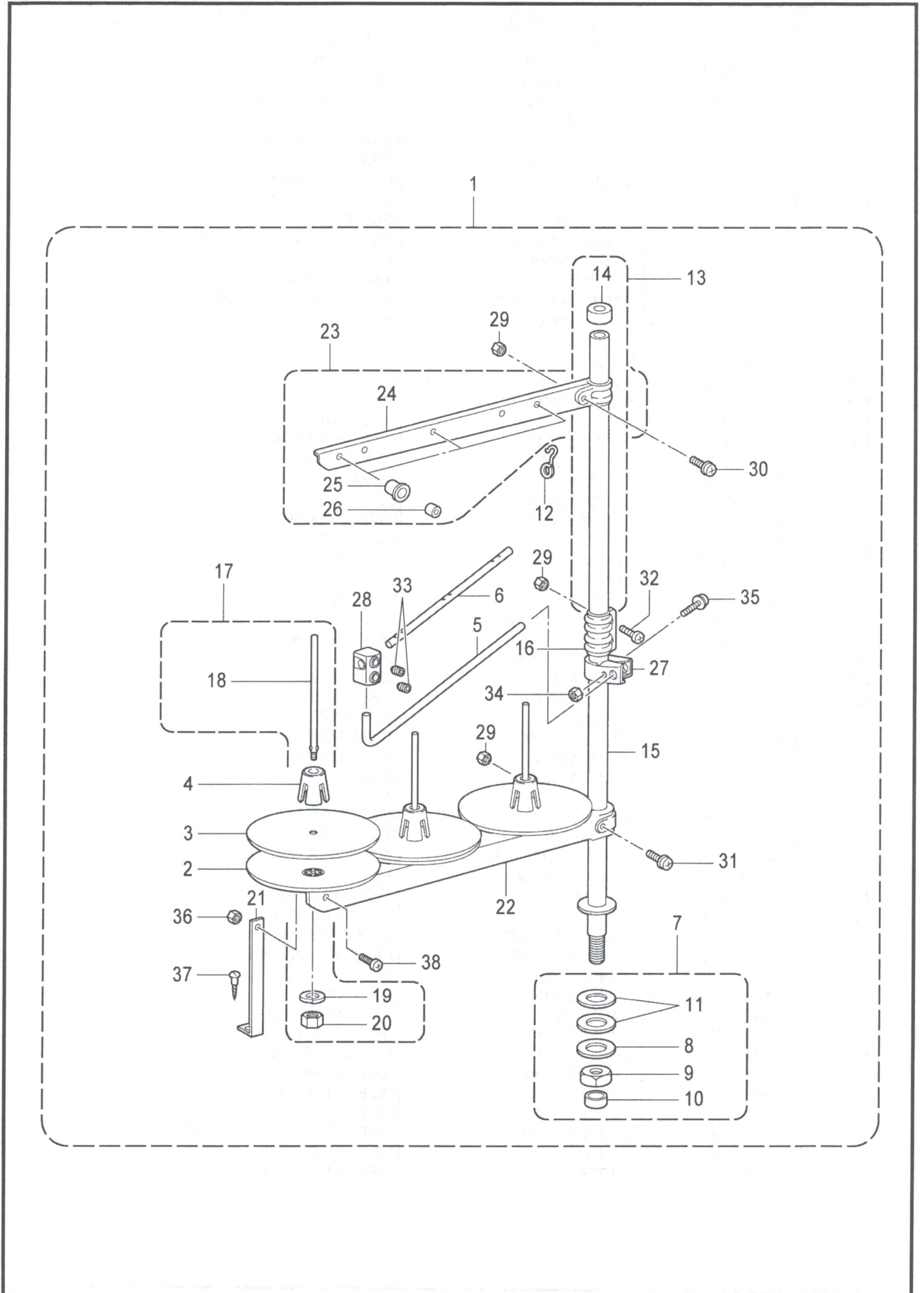

Z2. 付属品関係 / Accessories

REF.NO	CODE	Q'TY	品名	NAME OF PARTS	RM
1	S07558309	1	イトタテダイクミ3DRTHF	COTTON STAND ASSY, 3DRTHF	
2	S51283001	3	ウケザラ	SPOOL STAND BASE	
3	150182000	3	スプールマット	SPOOL MAT	
4	S51282101	3	スプールクッション	SPOOL CUSHION	
5	S04109001	1	イトアンナイササエボウ	THREAD GUIDE SUPPORT BAR	
6	142997001	1	イトアンナイ3	THREAD GUIDE, 3	
7	SA2867001	1	パイプDネジセットB	PIPE D SCREW SET, B	
8	150206002	1	ヒラザガネ16	WASHER, PLAIN 16	
9	S38648001	1	6カクナツU5/8	NUT, U5/8-28	
10	150174000	1	コラムキャップ	COLUMN CAP	
11	S01005000	2	イトタテゴム	RUBBER WASHER	
12	S02747101	1	イトカケバネ	SPRING	
13	S40639001	1	コラムパイプキャップツキ	COLUMN PIPE W/CAP	
14	150174000	1	コラムキャップ	COLUMN CAP	
15	156112003	1	コラムパイプD	COLUMN PIPE, D	
16	150173003	1	コラムジョイント	COLUMN JOINT	
17	S21798001	3	スプールネジセット	SPOOL & SCREW SET	
18	150179002	3	スプールジク	SPOOL SHAFT, B	
19	028050246	3	バネザガネ2-5	WASHER SPRING 2-5	
20	021500106	3	1シュナツ5	NUT 1 M5	
21	150188009	1	スプールホルダ-ササエA	SPOOL HOLDER SUPPORT, A	
22	S02779009	1	スプールホルダ-3	SPOOL HOLDER, 3	
23	S02788009	1	スレツドハンガ-クミ3	THREAD HANGER ASSY, 3	
24	S02789009	1	スレツドハンガ-3	THREAD HANGER, 3	
25	150183000	3	イトカケハンガ-ダイ	THREAD HANGER BASE	
26	142990001	3	スレツドブツシユ	THREAD BUSH	
27	150185009	1	イトアンナイホルダ-	THREAD GUIDE HOLDER	
28	138843001	1	ササエボウツギテ	JOINT	
29	021500106	4	1シュナツ5	NUT 1 M5	
30	S37038001	1	ナベコヒラザ5X14	SCREW, PAN(S/P WASHER) M5X14	
31	S37037001	1	ナベコヒラザ5X32	SCREW, PAN (S/P WASHER) M5X32	
32	062501406	2	ナベコ5X14	SCREW PAN M5X14	
33	014060632	2	アナクボミ6X6	SET SCREW SOCKET (CP) M6X6	
34	021500106	1	1シュナツ5	NUT 1 M5	
35	S37037001	1	ナベコヒラザ5X32	SCREW, PAN (S/P WASHER) M5X32	
36	021500106	1	1シュナツ5	NUT 1 M5	
37	031452206	1	マルモク45X22	WOOD SCREW ROUND M4.5X22	
38	062501006	1	ナベコ5X10	SCREW PAN M5X10	

Wa. 警告ラベル / Warning labels

警告ラベル / Warning labels	品名 / Name of parts	Size(mm)	Code
	<p>ラベル注意・和英 Label, caution Jpn / Eng</p>	<p>64 X 40</p>	<p>SA2040-001</p>
	<p>ラベル注意・中英 Label, caution Chn / Eng</p>	<p>64 X 40</p>	<p>SA2041-001</p>
	<p>アースマーク Label, grounding</p>	<p>φ 12</p>	<p>S37060-001</p>

T-8450B-Wa

Sp.仕様別部品一覧表 / Different parts

■ かま / Rotary hooks

かまは下記のオプションパーツを用意しています。用途に合わせてご使用ください。
(部品コードは、かまが箱に入った組コードです)

The following type of rotary hook are available. Select whichever one is suitable for your application.
(The following parts codes are assigned for the rotary hooks in the boxes.)

●標準 / Normal

	全仕様 / All type
かま箱組 / Rotary hook assy	SA1681-111

●オプション / Option

○オープン給油 / Extra lubrication rotary hook

かまへの油量が多いので、レース部の磨耗を防ぎます。厚物や極厚物の縫製に適しています。

Sufficient oil supplied to the rotary hook to prevent wear of the rotary hook race.

This type is suitable for sewing heavy and extra heavy materials.

	全仕様 / All type
かま箱組 / Rotary hook assy	SA1682-111

Ga. ゲージ部品一覧表 / Gauge parts List

標準品 / For normal

針幅 Needle gauge (mm)	針抱きセット Needle clamp set	針抱き組 Needle clamp assy	針板 Needle plate	送り歯 Feed dog	押え組 Presser foot assy
			中厚,厚物用 (-3, -5) For medium & heavy materials	中厚,厚物用 (-3,-5) For medium & heavy materials	
1/8 (3.2)	(L)S15711-001 (R)S15712-001	(L)S15713-001 (R)S15714-001	117369-001	114951-001	S36544-001
5/32 (4.0)	(L)S15717-001 (R)S15718-001	(L)S15719-001 (R)S15720-001	150850-001	116509-001	116502-001
3/16 (4.8)	(L)S15723-001 (R)S15724-001	(L)S15725-001 (R)S15726-001	117133-001	112659-001	SA4053-001
1/4 (6.4)	(L)S15735-001 (R)S15736-001	(L)S15737-001 (R)S15738-001	117367-001	112660-001	SA4049-001
5/16 (7.9)	(L)S15747-001 (R)S15748-001	(L)S15749-001 (R)S15750-001	144882-001	112661-001	112645-001
3/8 (9.5)	(L)S15753-001 (R)S15754-001	(L)S15755-001 (R)S15756-001	144881-101	116510-101	116498-001
7/16 (11.1)	(L)S15759-001 (R)S15760-001	(L)S15761-001 (R)S15762-001	151596-001	151598-001	151597-101
1/2 (12.7)	(L)S15765-001 (R)S15766-001	(L)S15767-001 (R)S15768-001	S09365-001	116511-001	116499-101
5/8 (15.9)	(L)S15771-001 (R)S15772-001	(L)S15773-001 (R)S15774-001	159577-001	116512-001	116500-101

空縫い用 / For sewing without material

- * 針板と送り歯と押え組が標準品と異なります。最大送りピッチは4mm以下でご使用下さい。
- * Needle plate, the feed dog and presser foot assembly is different from normal parts.
- * Use gauge components of for sewing without material which have a maximum feed pitch of 4mm or less.

針幅 Needle gauge (mm)	(針抱きセット) Needle clamp set	(針抱き組) Needle clamp assy	針板 Needle plate	送り歯 Feed dog	押え組 Presser foot assy
3/16 (4.8)	標準品 / Normal	標準品 / Normal	S36010-101	S36011-101	S36012-001
1/4 (6.4)			S36025-001	S36024-001	S36022-001

薄物用 / For light materials

- * 送り歯が標準品と異なります。
- * The feed dog is different from normal parts.

針幅 Needle gauge (mm)	(針抱きセット) Needle clamp set	(針抱き組) Needle clamp assy	(針板) Needle plate	送り歯 Feed dog	(押え組) Presser foot assy
1/8 (3.2)	標準品 / Normal	標準品 / Normal	標準品 / Normal	S07880-001	標準品 / Normal
3/16 (4.8)				S07878-001	
1/4 (6.4)				S07879-001	

Ga . ゲージ部品一覧表 / Gauge parts List

標準品 / For normal

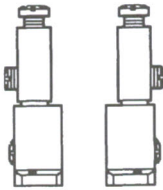
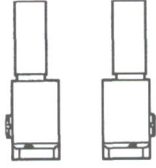
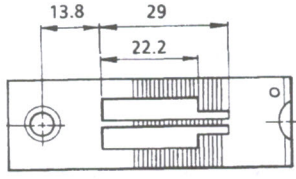
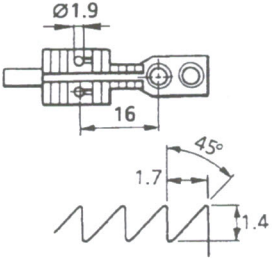
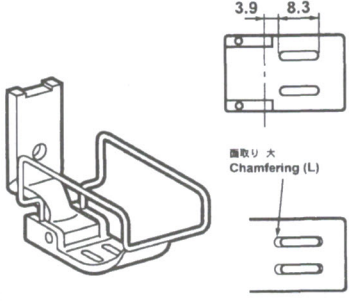
<p>針抱きセット Needle clamp set</p>	<p>針抱き組 Needle clamp assy</p>	<p>針板 Needle plate</p> <p>中、厚物用(-3,-5) For medium & heavy materials</p>
		
<p>送り歯 Feed dog</p> <p>中厚, 厚物用(-3, -5) For medium & heavy materials</p>	<p>押え組 Presser foot assy</p>	
		

空縫い用 / For sewing without material

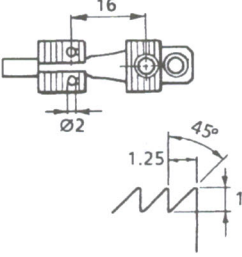
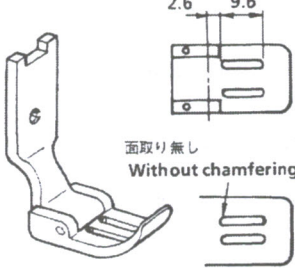
<p>針板 Needle plate</p>	<p>送り歯 Feed dog</p>	<p>押え組 Presser foot assy</p>
		

薄物用 / For light materials

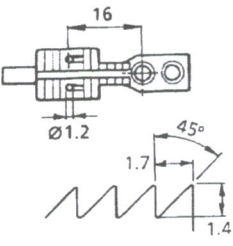
<p>送り歯 Feed dog</p>

Ga . ゲージ部品一覧表 / Gauge parts List

厚物用 / For heavy materials

* 送り歯が標準品と異なります。

* The feed dog is different from normal parts.

針幅 Needle gauge (mm)	(針抱きセット) Needle clamp set	(針抱き組) Needle clamp assy	(針板) Needle plate	送り歯 Feed dog	(押え組) Presser foot assy
3/16 (4.8)	標準品 / Normal	標準品 / Normal	標準品 / Normal	S21149-001	標準品 / Normal
1/4 (6.4)				S21150-001	

極厚物用 / For extra heavy materials

* 送り歯が標準品と異なります。

* The feed dog is different from normal parts.

針幅 Needle gauge (mm)	(針抱きセット) Needle clamp set	(針抱き組) Needle clamp assy	(針板) Needle plate	送り歯 Feed dog	(押え組) Presser foot assy
1/8 (3.2)	標準品 / Normal	標準品 / Normal	標準品 / Normal	158430-001	標準品 / Normal
3/16 (4.8)				S13588-001	
1/4 (6.4)				153882-001	
3/8 (9.5)				153887-001	
1/2 (12.7)				153892-001	
5/8 (15.9)				153897-001	

オプション部品 / Option parts

* 押え組が標準品と異なります。案内付押えは、最大送りピッチ 4mm 以下でご使用下さい。

* The presser foot assembly is different from normal parts.

* The presser foot assembly with guide should be used with a maximum feed pitch of 4mm or less.

品名 Name of parts	針幅 Needle gauge (mm)	(針抱き組) Needle clamp assy	(針板) Needle plate	(送り歯) Feed dog	押え組 Presser foot assy
案内付き押え組 Presser foot assy with guide	1/8 (3.2)	標準品 / Normal	標準品 / Normal	標準品 / Normal	149311-001
	3/16 (4.8)				117281-001
	1/4 (6.4)				149312-001
左案内付き押え Presser foot assy with guide, L	5/16 (7.9)				S13735-001
ファスナー付け用 Presser foot assy for attach zipper (Right)	1/8 (3.2)				S14080-001
左ファスナー付け用 Presser foot assy for attach zipper (Left)	1/8 (3.2)				S33459-001

Ga. ゲージ部品一覧表 / Gauge parts List

厚物用 / For heavy materials

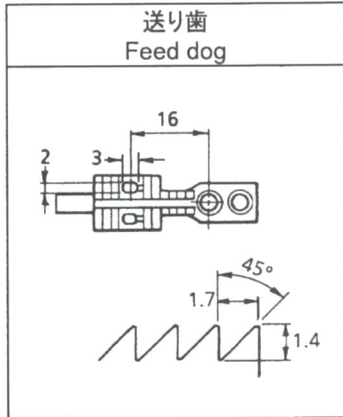

極厚物用 / For extra heavy materials

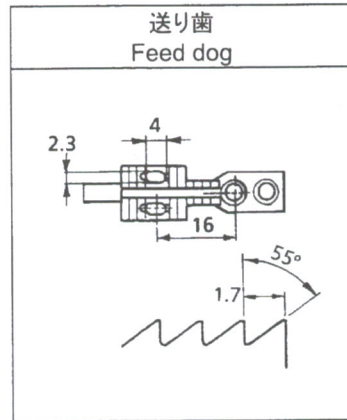

オプション部品 / Option parts

案内付き押え組 Presser foot assy with guide	左案内付き押え Presser foot assy with guide, L	ファスナー付け用 Presser foot assy for attach zipper (Right)	左ファスナー付け用 Presser foot assy for attach zipper (Left)
<p>面取り小 Chamfering (S)</p>	<p>面取り無し Without chamfering</p>	<p>面取り大 Chamfering (L)</p>	<p>面取り大 Chamfering (L)</p>

Ga. ゲージ部品一覧表 / Gauge parts List

下送り用 / For drop Feed

* 最大針幅 5/8"(15.9mm)まで出来ます。

* A maximum stitch width specification of 5/8" (15.9 mm) is available.

針幅 Needle gauge (mm)	針抱きセット Needle clamp set	針抱き組 Needle clamp assy	針板 Needle plate	送り歯 Feed dog	押え組 Presser foot assy
1/8 (3.2)	(L)S15711-001 (R)S15712-001	(L)S15713-001 (R)S15714-001	S07686-001	S07696-001	S38544-001
3/16 (4.8)	(L)S15723-001 (R)S15724-001	(L)S15725-001 (R)S15726-001	S07688-001	S07698-001	S38542-001
1/4 (6.4)	(L)S15735-001 (R)S15736-001	(L)S15737-001 (R)S15738-001	S07689-001	S07699-001	S38543-001
1/2 (12.7)	(L)S15765-001 (R)S15766-001	(L)S15767-001 (R)S15768-001	S07693-001	S07703-001	S07684-101

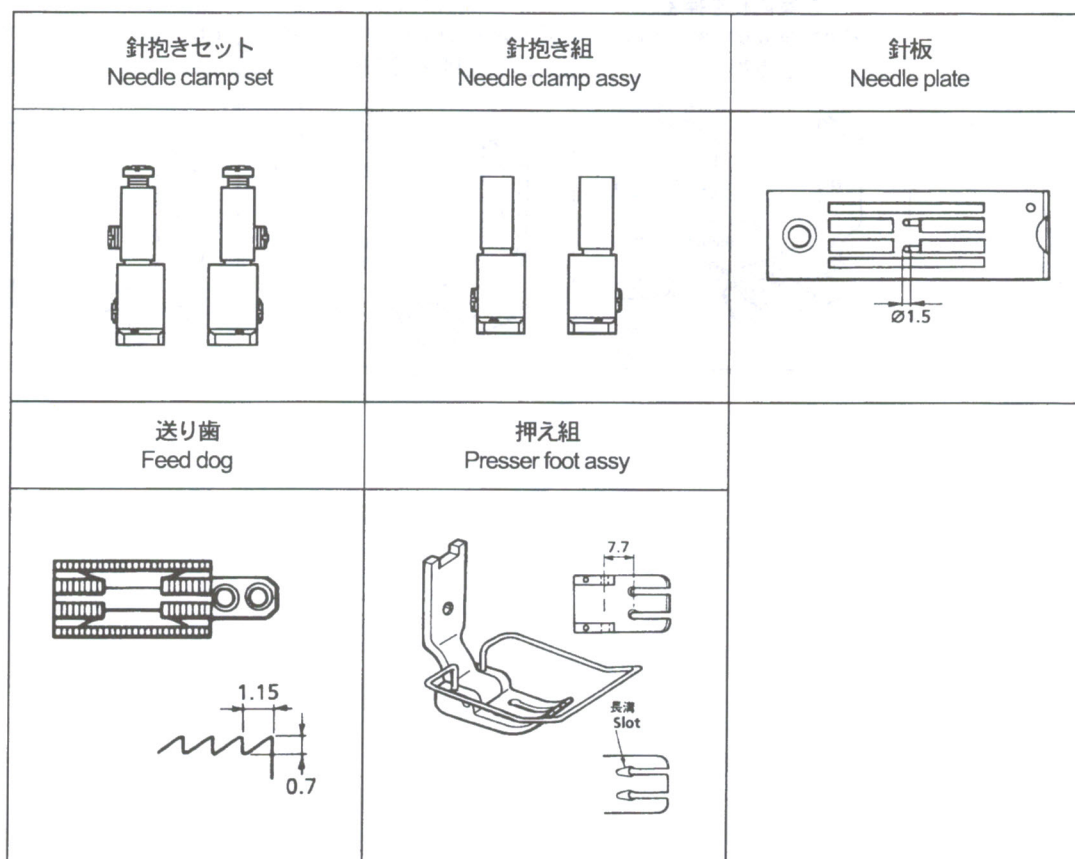

CODE	REF.NO	Page	CODE	REF.NO	Page	CODE	REF.NO	Page	CODE	REF.NO	Page
012060636	C -55	8	062061016	L -68	28	100666002	Z1 -43	34	143613051	F -16	14
	F -32	14	062061616	C -48	8	100887001	Z1 -5	34	143616001	F -17	14
	G -7	16	062260316	C -16	6	104449001	A -4	2	143882001	Z1 -30	34
	G -27	16	062300416	G -24	16	104450101	L -19	26	143910009	Z1 -31	34
	M -44	30	062300612	J1 -19	18		L -45	26	144226001	Z1 -15	34
012061036	B -21	4	062300616	M -39	30		L -61	26	144504001	M -27	30
	B -25	4	062350512	M -22	30	104821001	F -44	14	144881101	Ga	39
012061832	E -14	12	062350516	C -20	6	104833001	D -2	10	144882001	Ga	39
012500536	E -22	12		C -42	8	107155001	C -39	6	145446001	M -23	30
	J1 -15	18		D -8	10	107415014	Z1 -11	34		N -29	32
	M -31	30	062350616	C -37	6	107415022	Z1 -11	34	145573000	Z1 -16	34
	N -8	32	062350816	C -32	6	108549001	F -23	14	146039001	Z1 -48	34
	N -13	32	062400616	G -19	16	108801001	L -59	26	146293001	Z1 -26	34
	N -33	32		G -34	16	108802001	G -5	16	149311001	Ga	41
013660412	H -3	22		J1 -27	18		L -58	26	149312001	Ga	41
014060632	Z2 -33	36		J1 -29	18	109714000	Z1 -34	34	149570001	Z1 -9	34
014080831	C -43	8		J1 -32	18	110087001	Z1 -54	34	149578000	Z1 -19	34
014400432	D -30	10		J1 -27	20	112609001	C -14	6	149604001	C -8	6
016061031	F -29	14		J1 -29	20	112645001	Ga	39	149605001	C -9	6
017762013	Z1 -50	34		J1 -32	20	112659001	Ga	39	149608001	C -13	6
018062032	C -50	8		L -64	28	112660001	Ga	39	149610001	C -17	6
	C -60	8	062401216	N -17	32	112661001	Ga	39	149611101	C -18	6
	F -15	14	062401616	L -54	26	112728001	C -33	6	149622001	C -25	6
018062532	C -57	8	062500616	A -9	2	112753001	L -67	28	149827001	C -10	6
018401036	C -4	6		L -57	26	113014000	B -7	4	149831101	H -5	22
021060306	E -15	12		N -27	32	113050001	H -10	22	149863001	D -28	10
	E -32	12	062500816	A -23	2	114483002	Z1 -46	34	150173003	Z2 -16	36
	Z1 -24	34		B -27	4	114486002	Z1 -45	34	150174000	Z2 -10	36
021300106	M -11	30		B -32	4	114941001	M -41	30		Z2 -14	36
021350106	G -16	16		D -16	10	114951001	Ga	39	150179002	Z2 -18	36
021500106	E -25	12		D -25	10	114967001	Z1 -53	34	150182000	Z2 -3	36
	F -53	14		E -2	12	115947001	J1 -42	20	150183000	Z2 -25	36
	Z2 -20	36		F -45	14	116010001	A -18	2	150185009	Z2 -27	36
	Z2 -29	36		L -8	26	116498001	Ga	39	150188009	Z2 -21	36
	Z2 -34	36		M -42	30	116499101	Ga	39	150206002	Z2 -8	36
	Z2 -36	36		Z1 -41	34	116500101	Ga	39	150820001	D -18	10
021500316	J1 -12	18		Z1 -42	34	116502001	Ga	39	150850001	Ga	39
025030132	G -23	16	062501006	Z2 -38	36	116509001	Ga	39	151025001	J2 -2	22
025050236	F -48	14	062501016	D -4	10	116510101	Ga	39	151027001	J2 -7	22
025050336	F -43	14		F -3	14	116511001	Ga	39	151034001	J2 -6	22
025060132	G -14	16		L -17	26	116512001	Ga	39	151035001	J2 -5	22
025060136	J1 -49	20	062501216	A -7	2	117133001	Ga	39	151596001	Ga	39
	N -6	32		F -42	14	117281001	Ga	41	151597101	Ga	39
	N -15	32		F -47	14	117367001	Ga	39	151598001	Ga	39
025060236	L -69	28		F -52	14	117369001	Ga	39	153230101	Z1 -27	34
025100132	F -36	14	062501406	Z2 -32	36	118735002	C -51	8	153882001	Ga	41
025710132	J1 -11	18	062501416	A -5	2	118837001	Z1 -3	34	153887001	Ga	41
025750132	Z1 -44	34		D -21	10	118954000	F -10	14	153892001	Ga	41
028050246	Z2 -19	36		E -24	12	122991001	Z1 -1	34	153897001	Ga	41
031452206	Z2 -37	36	071063550	D -19	10	129458102	F -22	14	154125001	Z1 -7	34
047301842	D -11	10	072600480	K -9	24	138843001	Z2 -28	36	154560001	M -28	30
048040342	N -2	32	076023800	B -17	4	140063001	A -1	2	154567000	C -44	8
	N -14	32	081004070	L -27	26	140890009	L -66	28	154965001	J1 -17	18
048060342	F -18	14		L -31	26	141208001	E -5	12	155510001	M -29	30
048080342	F -35	14	081009070	N -5	32	142002001	Z1 -6	34	156112003	Z2 -15	36
060350616	C -27	6	081038070	L -20	26	142274101	L -36	26	158115001	B -20	4
	C -30	6	0A4400806	L -46	26	142443001	Z1 -2	34		K -13	24
061350616	M -19	30	0A5501006	L -24	26	142721001	Z1 -8	34	158430001	Ga	41
	M -37	30	100032004	H -8	22	142746002	F -21	14	159577001	Ga	39
062060816	F -7	14	100328001	F -25	14	142990001	Z2 -26	36	159805001	M -24	30
	F -51	14	100401021	N -30	32	142997001	Z2 -6	36	228475000	L -13	26
	L -49	26	100463001	Z1 -49	34	143611201	F -8	14	S01005000	Z2 -11	36
062061016	J1 -48	20	100477009	Z1 -13	34	143612100	F -9	14	S01567001	J2 -3	22

索引 / INDEX

CODE	REF.NO	Page	CODE	REF.NO	Page	CODE	REF.NO	Page	CODE	REF.NO	Page
S01568001	J2 -4	22	S15714001	Ga	39	S25236001	B -12	4	SA1752014	Z1 -10	34
S01928151	J1 -50	20		Ga	43		F -13	14	SA1752022	Z1 -10	34
	Z1 -12	34	S15717001	Ga	39		K -11	24	SA1962001	Z1 -32	34
S02747101	Z2 -12	36	S15718001	Ga	39	S25260001	B -8	4	SA1963001	Z1 -33	34
S02779009	Z2 -22	36	S15719001	Ga	39		C -46	8	SA1969001	Z1 -29	34
S02788009	Z2 -23	36	S15720001	Ga	39	S25289001	E -9	12	SA1971101	N -1	32
S02789009	Z2 -24	36	S15723001	Ga	39	S25344001	Z1 -22	34	SA1975001	N -3	32
S04109001	Z2 -5	36		Ga	43	S25475101	Z1 -23	34	SA1978001	N -4	32
S05246000	L -35	26	S15724001	Ga	39	S25789000	N -9	32	SA1980001	N -7	32
S07346101	E -6	12		Ga	43	S31006001	E -11	12	SA1981101	N -10	32
S07349001	E -20	12	S15725001	Ga	39	S31032001	N -31	32	SA1982101	N -11	32
S07350001	E -33	12		Ga	43	S31885001	Z1 -55	34	SA1983001	N -12	32
S07353001	E -13	12	S15726001	Ga	39	S33459001	Ga	41	SA1984001	N -16	32
S07355051	E -23	12		Ga	43	S34438051	A -17	2	SA1985001	N -18	32
S07374109	F -38	14	S15735001	Ga	39	S34561001	C -11	6	SA1988001	N -20	32
S07376101	F -49	14		Ga	43	S34562001	C -12	6	SA1989001	N -21	32
S07419001	J1 -6	18	S15736001	Ga	39	S34756001	Z1 -52	34	SA1990101	N -22	32
S07420000	J1 -5	18		Ga	43	S36010101	Ga	39	SA1991001	N -23	32
S07494001	H -12	22	S15737001	Ga	39	S36011101	Ga	39	SA1992101	N -25	32
S07558309	Z2 -1	36		Ga	43	S36012001	Ga	39	SA1994001	N -28	32
S07575000	C -23	6	S15738001	Ga	39	S36022001	Ga	39	SA2040001	A -22	2
S07575001	C -23	6		Ga	43	S36024001	Ga	39		Wa	37
S07575002	C -23	6	S15747001	Ga	39	S36025001	Ga	39	SA2041001	A -22	2
S07575003	C -23	6	S15748001	Ga	39	S36544001	Ga	39		Wa	37
S07575004	C -23	6	S15749001	Ga	39	S36663051	A -16	2	SA2165001	E -29	12
S07575005	C -23	6	S15750001	Ga	39	S37037001	Z2 -31	36	SA2190001	N -24	32
S07575006	C -23	6	S15753001	Ga	39		Z2 -35	36	SA2441001	A -6	2
S07575007	C -23	6	S15754001	Ga	39	S37038001	Z2 -30	36	SA2444001	A -10	2
S07575008	C -23	6	S15755001	Ga	39	S37060001	A -21	2	SA2445001	A -11	2
S07575009	C -23	6	S15756001	Ga	39		Wa	37	SA2447001	A -12	2
S07575010	C -23	6	S15759001	Ga	39	S37263001	Z1 -40	34	SA2449001	A -14	2
S07575011	C -23	6	S15760001	Ga	39	S38212001	J1 -16	18	SA2463001	B -24	4
S07588101	D -26	10	S15761001	Ga	39	S38266000	L -10	26	SA2469001	B -26	4
S07684101	Ga		S15762001	Ga	39	S38274001	M -32	30	SA2474101	C -3	6
S07686001	Ga		S15765001	Ga	39	S38278001	Z1 -51	34	SA2479001	A -13	2
S07688001	Ga			Ga	43	S38300001	Z1 -47	34		A -15	2
S07689001	Ga		S15766001	Ga	39	S38398001	B -5	4	SA2485001	C -45	8
S07693001	Ga			Ga	43	S38427001	F -19	14	SA2486101	C -47	8
S07696001	Ga		S15767001	Ga	39	S38542001	Ga	43	SA2489001	C -49	8
S07698001	Ga			Ga	43	S38543001	Ga	43	SA2490101	C -52	8
S07699001	Ga		S15768001	Ga	39	S38544001	Ga	43	SA2493001	C -58	8
S07703001	Ga			Ga	43	S38648001	Z2 -9	36	SA2494001	C -59	8
S07746001	J2 -8	22	S15771001	Ga	39	S38707001	B -4	4	SA2495001	E -1	12
S07876101	L -43	26	S15772001	Ga	39	S39051001	E -12	12	SA2496001	E -7	12
S07878001	Ga	39	S15773001	Ga	39	S39830101	F -27	14	SA2498001	E -8	12
S07879001	Ga	39	S15774001	Ga	39	S40639001	Z2 -13	36	SA2499001	E -10	12
S07880001	Ga	39	S15889001	Z1 -25	34	S48190000	L -15	26	SA2500001	E -16	12
S09260001	J1 -4	18	S17774001	Z1 -4	34	S48204000	C -62	8	SA2501001	E -17	12
S09261001	J1 -4	18	S18964001	D -15	10	S48367000	F -41	14	SA2502001	E -18	12
S09365001	Ga	39	S20681000	M -25	30	S49623000	L -14	26	SA2504001	E -21	12
S11244001	H -7	22	S20682105	M -26	30	S50098101	F -24	14	SA2506001	E -26	12
S12441001	N -32	32	S21149001	Ga	41	S51282101	Z2 -4	36	SA2507001	E -27	12
S13085001	H -4	22	S21150001	Ga	41	S51283001	Z2 -2	36	SA2509001	F -1	14
S13160001	B -15	4	S21798001	Z2 -17	36	S55663001	Z1 -14	34	SA2511001	F -2	14
S13588001	Ga	41	S23418002	N -19	32	SA1120001	B -9	4	SA2512001	F -4	14
S13735001	Ga	41		Z1 -28	34	SA1174001	E -3	12	SA2515001	F -5	14
S14080001	Ga	41	S23460001	C -53	8	SA1175001	E -4	12	SA2516001	F -6	14
S15711001	Ga	39	S23651001	B -10	4	SA1179001	E -19	12	SA2518001	F -11	14
	Ga	43		B -18	4		E -28	12	SA2521001	F -14	14
S15712001	Ga	39		G -9	16		E -30	12	SA2523001	F -26	14
	Ga	43	S23773001	D -22	10	SA1360001	N -26	32	SA2525001	F -28	14
S15713001	Ga	39	S25234001	B -3	4	SA1681111	Sp	38	SA2526001	F -30	14
	Ga	43	S25235001	B -11	4	SA1682111	Sp	38	SA2527001	F -31	14

CODE	REF.NO	Page	CODE	REF.NO	Page	CODE	REF.NO	Page	CODE	REF.NO	Page
SA2528101	F -33	14	SA2632001	M -30	30	SA3840001	G -10	16	SA4396001	C -26	6
SA2529101	F -34	14	SA2633001	M -33	30	SA3855001	G -1	16	SA4397001	C -28	6
SA2530001	F -37	14	SA2634001	M -36	30	SA3856001	J1 -8	18	SA4398001	C -29	6
SA2531001	F -39	14	SA2635001	M -38	30	SA3859001	J1 -9	18	SA4399001	C -31	6
SA2532001	F -46	14	SA2636001	M -43	30	SA3864001	G -11	16	SA4400001	C -38	6
SA2533001	F -50	14	SA2637001	M -45	30	SA3886001	G -12	16	SA4401001	C -36	6
SA2543001	G -4	16	SA2638001	M -46	30	SA3887001	G -21	16	SA4402001	D -1	10
SA2544001	G -6	16	SA2639001	M -40	30	SA3888001	G -22	16	SA4404001	D -5	10
SA2546001	G -8	16	SA2640001	M -47	30	SA3889101	J1 -13	18	SA4405001	D -7	10
SA2550001	G -25	16	SA2691101	Z1 -17	34	SA3890001	K -1	24	SA4406001	D -10	10
SA2551001	G -26	16	SA2692101	Z1 -18	34	SA3891001	K -3	24	SA4408001	D -12	10
SA2553001	G -17	16	SA2720101	B -22	4	SA3894001	J1 -31	18	SA4409001	D -13	10
SA2554001	G -18	16	SA2722001	J1 -43	20		J1 -31	20	SA4411101	D -14	10
SA2555001	G -28	16	SA2723001	L -21	26	SA3896001	L -25	26	SA4412001	D -17	10
SA2556001	J1 -41	20	SA2724001	G -35	16	SA3898001	L -29	26	SA4413001	D -20	10
	J1 -45	20		L -22	26	SA3916001	J1 -39	20	SA4414001	D -23	10
SA2557001	J1 -7	18	SA2727101	L -34	26	SA3923001	L -53	26	SA4415001	D -24	10
SA2560001	J1 -10	18	SA2748001	B -16	4	SA3924001	A -2	2	SA4416001	D -27	10
SA2562101	J1 -18	18	SA2750001	B -19	4	SA3946001	L -3	26	SA4417001	D -29	10
SA2563101	J1 -34	18	SA2759001	K -6	24	SA3961001	J1 -2	18	SA4418001	D -31	10
SA2565001	J1 -44	20	SA2768101	Z1 -37	34	SA3965001	G -2	16	SA4419001	D -15	10
SA2566001	G -15	16	SA2769001	Z1 -38	34	SA3988001	J1 -38	20	SA4420101	J1 -1	18
SA2567001	J1 -46	20	SA2770101	Z1 -39	34	SA3990001	G -20	16	SA4421101	J1 -33	18
SA2568001	J1 -47	20	SA2806001	G -31	16	SA4009001	G -33	16	SA4441001	D -6	10
SA2571001	K -5	24	SA2814201	L -1	26	SA4011001	G -36	16	SA4444001	J1 -4	18
SA2574001	J1 -21	18	SA2824001	M -20	30	SA4012001	J1 -30	18	SA4506001	M -34	30
	J1 -24	18	SA2825001	J1 -40	20		J1 -30	20	SA4507001	M -35	30
	J1 -24	20	SA2861001	B -13	4	SA4014001	L -65	28	SA4537001	B -28	4
SA2575001	J1 -22	18	SA2867001	Z2 -7	36	SA4026001	J1 -14	18	SA4538001	G -30	16
	K -7	24	SA2927001	G -13	16	SA4028001	G -3	16	SA4549001	J1 -20	18
SA2576001	J1 -23	18	SA2928001	G -29	16	SA4029001	J1 -3	18	SA4550001	B -1	4
SA2579001	J1 -35	20	SA2929001	A -20	2	SA4033101	L -12	26	SA4583001	C -24	6
SA2582001	Z1 -20	34		L -9	26	SA4038001	J1 -4	18	SA4585001	K -2	24
SA2584001	K -8	24		L -18	26	SA4042001	J1 -26	18		K -4	24
SA2585001	F -12	14	SA2936101	B -14	4	SA4043001	J1 -36	20	SA5154001	L -16	26
	K -10	24	SA2956001	L -4	26	SA4044001	J1 -28	18	SA5155001	C -40	6
	K -14	24	SA2957001	L -5	26	SA4045001	J1 -37	20	SA5224001	L -11	26
SA2587101	K -12	24	SA3037001	L -37	26	SA4049001	Ga	39	SA5237001	C -41	8
SA2590001	Z1 -21	34	SA3040001	L -2	26	SA4053001	Ga	39	SA5332001	C -61	8
SA2596001	L -41	26		L -38	26	SA4117001	C -54	8	SA5333001	D -9	10
SA2597001	L -42	26	SA3044001	L -50	26	SA4118001	C -56	8	SA5336001	D -3	10
SA2598101	L -44	26	SA3045101	L -47	26	SA4149001	E -31	12	W01519001	G -32	16
SA2599001	L -26	26	SA3046001	L -48	26	SA4212001	M -3	30			
	L -30	26	SA3047001	L -52	26	SA4213001	K -15	24			
SA2604001	L -55	26	SA3048101	L -62	26	SA4214001	B -23	4			
SA2605001	L -56	26	SA3049001	L -63	26	SA4335001	B -6	4			
SA2606101	L -60	26	SA3054001	J1 -25	18	SA4364001	A -3	2			
SA2607001	M -1	30	SA3055101	L -6	26	SA4370001	A -8	2			
SA2613001	M -4	30		L -7	26	SA4373001	B -2	4			
SA2614001	M -5	30		L -23	26	SA4376101	B -29	4			
SA2615001	M -6	30		L -51	26	SA4377001	C -1	6			
SA2619001	M -7	30	SA3056001	F -20	14	SA4378001	C -2	6			
SA2620001	M -9	30	SA3059001	B -31	4	SA4382001	C -5	6			
SA2621001	M -10	30	SA3060001	L -39	26	SA4385001	C -6	6			
SA2623001	M -8	30	SA3061001	L -33	26	SA4387001	C -7	6			
SA2624001	M -13	30	SA3065001	B -30	4	SA4387002	C -7	6			
SA2625001	M -14	30	SA3067001	F -40	14	SA4387003	C -7	6			
SA2626001	M -12	30	SA3147001	L -28	26	SA4389001	C -21	6			
	M -15	30		L -32	26	SA4391001	C -15	6			
SA2627001	M -16	30		L -40	26	SA4392001	C -19	6			
SA2628001	M -17	30	SA3415001	M -2	30	SA4393001	C -34	6			
SA2629001	M -18	30	SA3416001	M -2	30	SA4394001	C -35	6			
SA2630001	M -21	30	SA3417001	M -1	30	SA4395001	C -22	6			

brother[®]

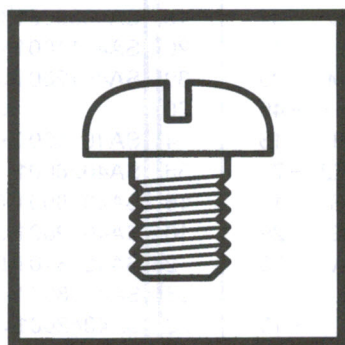

パーツブック
PARTS BOOK

ブラザー工業株式会社 <http://www.brother.co.jp/>

〒467-8561 名古屋市瑞穂区苗代町 15 番 1 号 TEL (052) 824-2392

BROTHER INDUSTRIES, LTD. <http://www.brother.com/>

15-1, Naeshiro-cho, Mizuho-ku, Nagoya 467-8561, Japan. Phone : 81-52-824-2177

T-8450 B
SA4424-001
2004.09.BB (1)