

S-7200B

パーツブック
PARTS BOOK

本縫ダイレクトドライブ自動糸切りミシン

SINGLE NEEDLE DIRECT DRIVE STRAIGHT LOCK STITCHER WITH
THREAD TRIMMER

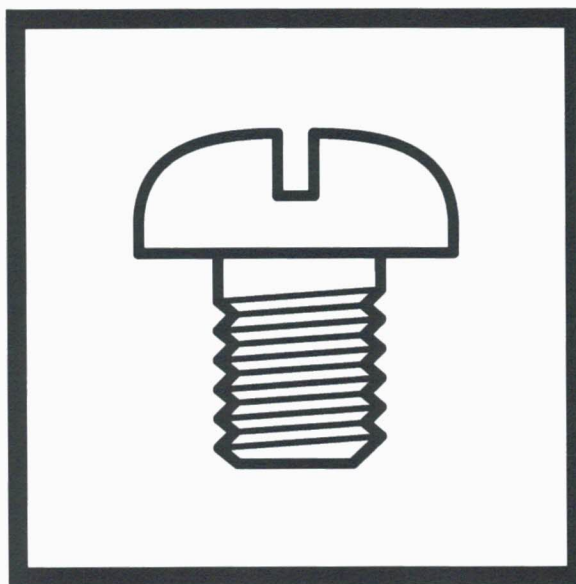

brother[®]

最新の部品情報は Parts Navigation でご覧いただけます。 <http://partsbook.brother.co.jp/partsnavi/jpn/>
The latest parts information, refer to the Parts Navigation. <http://partsbook.brother.co.jp/partsnavi/eng/>

型式板の見方

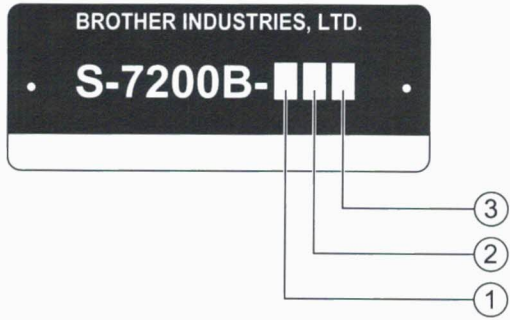

- ① — 3: 糸切り + 逆転
- ① — 4: 糸切り + 逆転 + 糸払い

- ② — 0: 微量給油タイプ
- ② — 3: セミドライタイプ
- ② — 5: 完全ドライタイプ

- ③ — S: 薄物・難素材用
- ③ — 3: 中厚物用
- ③ — 5: 厚物用

Description of model plate

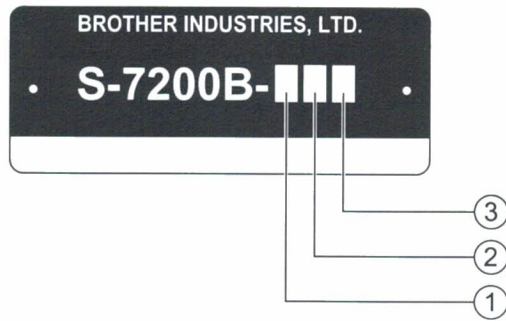

- ① — 3: Thread Trimmer + Quick Reverse
- ① — 4: Thread Trimmer + Quick Reverse + Thread Wiper

- ② — 0: Minimum lubrication type
- ② — 3: Semi dry type
- ② — 5: Complete dry type

- ③ — S: Light-weight Materials & Difficult-to-sew Materials
- ③ — 3: Medium-weight materials
- ③ — 5: Heavy-weight materials

パーツブックご利用に際して

1. この本は、2006年04月のデータに基づいて作成されたものです。
2. 部品は予告なしに設計変更される場合があります。
3. 組単位で補給する部品は、破線で示してあります。

目 次

A. 主体関係	1	Sp3. 仕様別部品一覧表 (中国向)	61
B. 針棒・天秤関係	3	Sp4. 仕様別部品一覧表 (輸出一般向)	62
C. 押え関係	7	Sp5. 仕様別部品一覧表 (欧州・カナダ向)	63
D. 送り関係	11	Ga1. ゲージ部品一覧表 (薄・中厚物用：3枚歯)	64
E. 膝上げ関係	17	Ga2. ゲージ部品一覧表 (薄・中厚物用：3枚歯)	65
F. 逆転関係	19	Ga3. ゲージ部品一覧表 (厚物用：3枚歯)	66
G. かま関係	21	Ga4. ゲージ部品一覧表 (難素材・新素材用：4枚歯)	67
H. 給油潤滑関係	23	Ga5. ゲージ部品一覧表 (薄・中厚物用：4枚歯)	68
J. 糸通し関係	27	Ga6. ゲージ部品一覧表 (薄・中厚物用：4枚歯)	69
K. 糸巻関係	29	Ga7. ゲージ部品一覧表 (薄・中厚物用：4枚歯)	70
L. 糸切り関係	31	Ga8. ゲージ部品一覧表 (薄・中厚物用：4枚歯)	71
M. 糸緩め関係	35	Ga9. ゲージ部品一覧表 (厚物用：4枚歯)	72
N. 糸払い関係	37	Wa. 警告ラベル	73
P1. コントロールボックス、モータ関係	39	索引	74
P2. コントロールボックス関係	41		
P3. コントロールボックス関係	43		
P4. コントロールボックス関係 (オプション部品)	45		
Q. 膝スイッチ関係	47		
R. 逆転スイッチ関係	49		
S. 電装品関係	51		
T. 電磁押え上げセット関係 (オプション部品)	53		
Z. 付属品関係	55		
Sp1. 仕様別部品一覧表 (日本向)	59		
Sp2. 仕様別部品一覧表 (アメリカ向)	60		

Notes for using this parts book

- 1 This book was prepared based on information available in April 2006.
- 2 Parts are subject to changes in design without prior notice.
- 3 Parts supplied as complete assemblies are circled by a dotted line.

CONTENTS

A. Machine body	1	Sp3. Different parts list (For China)	61
B. Needle bar and thread take-up mechanism	3	Sp4. Different parts list (For General export)	62
C. Presser foot mechanism	7	Sp5. Different parts list (For Europe & Canada)	63
D. Feed mechanism	11	Ga1. Gauge parts list (Light & medium-weight materials : 3ROW)	64
E. Knee lifter mechanism	17	Ga2. Gauge parts list (Light & medium-weight materials : 3ROW)	65
F. Quick reverse mechanism	19	Ga3. Gauge parts list (Heavy-weight materials : 3ROW)	66
G. Rotary hook mechanism	21	Ga4. Gauge parts list (Difficult-to-sew materials & Shin-gosen : 4ROW) ...	67
H. Lubrication	23	Ga5. Gauge parts list (Light & medium-weight materials : 4ROW)	68
J. Threading mechanism	27	Ga6. Gauge parts list (Light & medium-weight materials : 4ROW)	69
K. Bobbin winder mechanism	29	Ga7. Gauge parts list (Light & medium-weight materials : 4ROW)	70
L. Thread trimmer mechanism	31	Ga8. Gauge parts list (Light & medium-weight materials : 4ROW)	71
M. Tension release mechanism	35	Ga9. Gauge parts list (Heavy-weight materials : 4ROW)	72
N. Thread wiper mechanism	37	Wa. Warning labels	73
P1. Control box and motor mechanism	39	Index	74
P2. Control box mechanism	41		
P3. Control box mechanism	43		
P4. Control box mechanism (Option parts) ..	45		
Q. Knee switch mechanism	47		
R. Quick reverse switch mechanism	49		
S. Power supply equipment mechanism ...	51		
T. Presser foot lifting set mechanism (Option parts)	53		
Z. Accessories	55		
Sp1. Different parts list (For Japan)	59		
Sp2. Different parts list (For USA)	60		

A. 主体関係 / Machine body

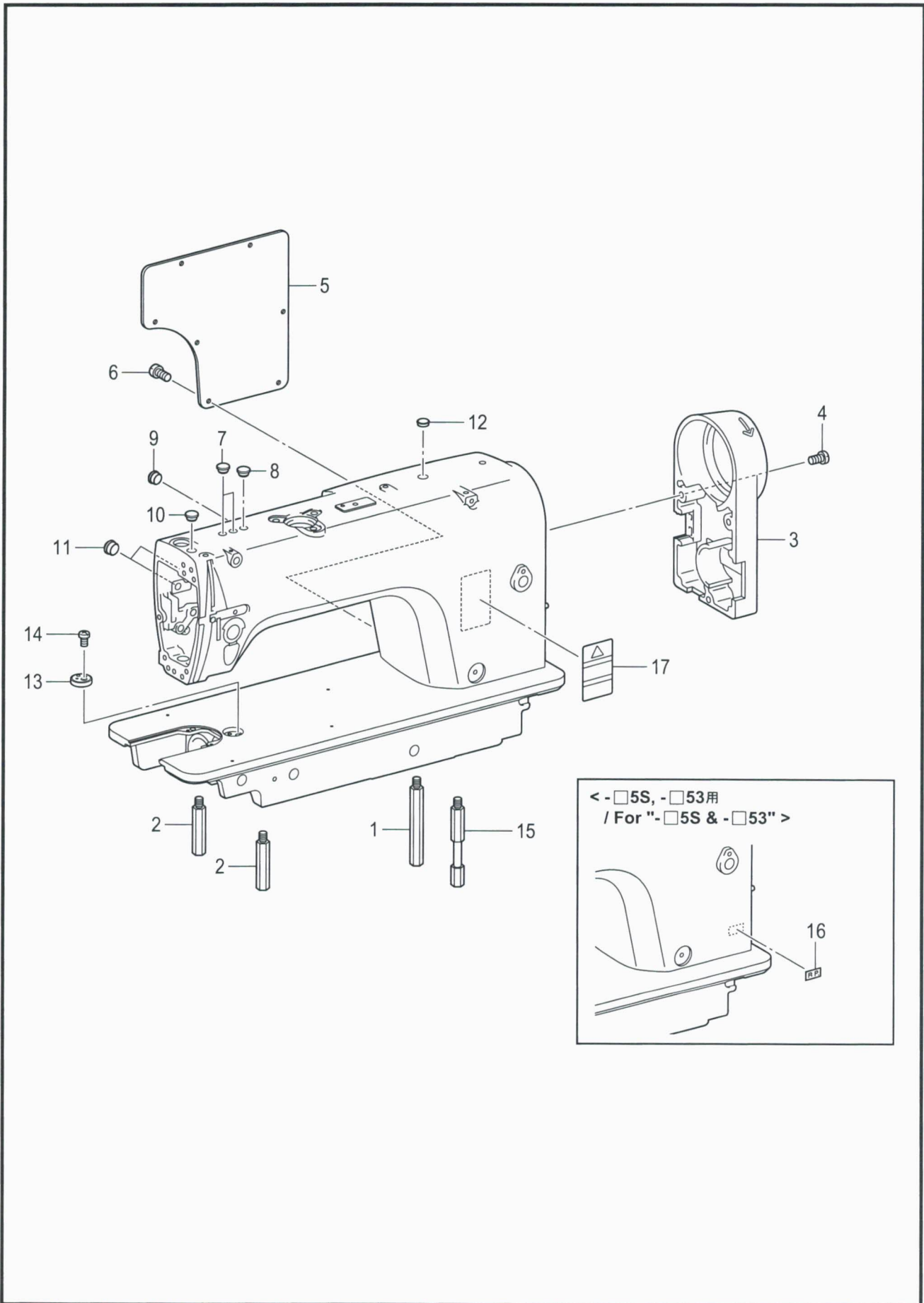

A. 主体関係 / Machine body

REF.NO	CODE	Q'TY	品名	NAME OF PARTS	RM
1	SA1106001	1	キヤクチュウR	STAND R	
2	SA1107001	2	キヤクチュウL	STAND L	
3	SA4259001	1	モータカバー	MOTOR COVER	
4	062501216	3	ナベコ5X12	SCREW PAN M5X12	
5	SA1105001	1	ガワイタ	SIDE PLATE	
6	062501216	7	ナベコ5X12	SCREW PAN M5X12	
7	104450101	2	ゴムセン8	RUBBER CAP, 8	
8	104450101	1	ゴムセン8	RUBBER CAP, 8	
9	S32263001	1	ゴムセン8.5	RUBBER CAP, 8.5	
10	104450101	1	ゴムセン8	RUBBER CAP, 8	
11	104449001	2	ゴムセン15.5	RUBBER CAP, 15.5	
12	117936001	1	ゴムセン9.4	RUBBER CAP, 9.4	
13	S09621151	1	ジヨウギイタ	RULER PLATE	
14	062400616	1	ナベコ4X6	SCREW PAN M4X6	
15	SA2170001	1	キヤクチュウRF	STAND RF	
16	S45050001	1	<-□5S, -□53用> RPマーク	<For "-□5S & -□53"> MARK, RP	
17	SA2040001	1	<日本向> ラベルチュウイ.ワエイ	<For Japan only> LABEL, CAUTION JPN/ENG	
17	SA2041001	1	<日本向以外> ラベルチュウイ.チュウエイ	<Except for Japan> LABEL, CAUTION CHN/ENG	

B. 針棒・天秤關係 / Needle bar and thread take-up mechanism

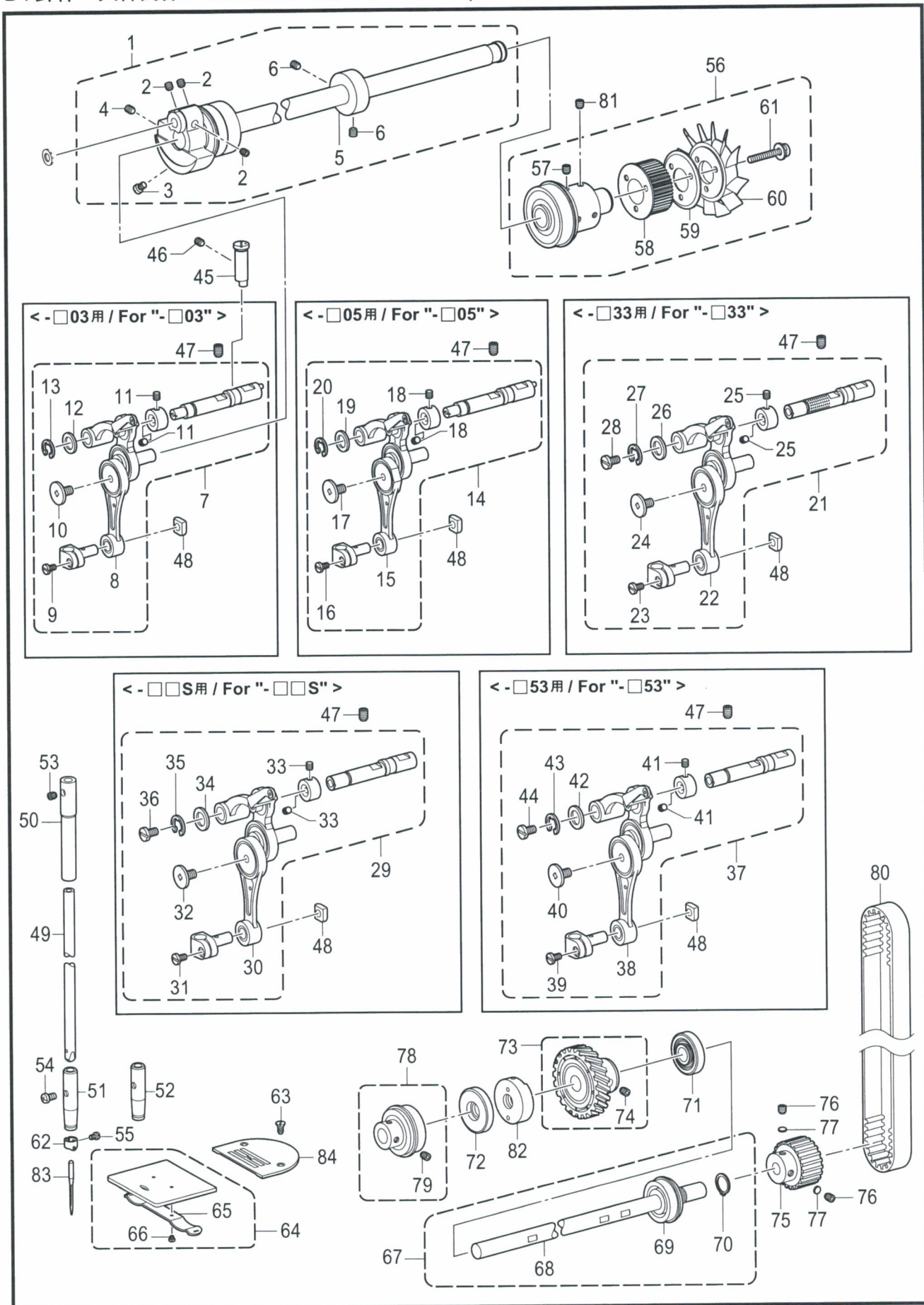

B. 針棒・天秤関係 / Needle bar and thread take-up mechanism

REF.NO	CODE	Q'TY	品名	NAME OF PARTS	RM
1	SA7209101	1	ウワジクミ	UPPER SHAFT ASSY	
2	S23651001	3	アナヒラ6X6ホソメ	SET SCREW SOCKET (FT) M6X6	
3	S25235001	1	シメネジ8	SCREW M8	
4	S25236001	1	アナヒラ6X10ホソメ	SET SCREW SOCKET (FT) M6X10	
5	SA1120001	1	イトマキドウリン	BOBBIN WINDER DRIVING WHEEL	
6	S23651001	2	アナヒラ6X6ホソメ	SET SCREW SOCKET (FT) M6X6	
			<-□03用>	<For "-□03">	
7	SA7212101	1	ハリボウレンカンソウクミ	NEEDLE BAR CONNECTING ROD UNIT	
8	SA7625001	1	ハリボウクランク	NEEDLE BAR CRANK	
9	140004001	1	シメネジ3.57	SCREW, SM3.57-40X7	
10	SA2422001	1	シメネジ3.57L	SCREW, SM3.57L	
11	012400436	2	アナヒラ4X4	SET SCREW SOCKET (FT) M4X4	
12	SA2161001	1	ザガネ	WASHER	
13	048060342	1	トメワE6	RETAINING RING E6	
			<-□05用>	<For "-□05">	
14	SA7222101	1	ハリボウレンカンソウクミ	NEEDLE BAR CONNECTING ROD UNIT	
15	SA7626001	1	ハリボウクランク	NEEDLE BAR CRANK	
16	140004001	1	シメネジ3.57	SCREW, SM3.57-40X7	
17	SA2422001	1	シメネジ3.57L	SCREW, SM3.57L	
18	012400436	2	アナヒラ4X4	SET SCREW SOCKET (FT) M4X4	
19	SA2161001	1	ザガネ	WASHER	
20	048060342	1	トメワE6	RETAINING RING E6	
			<-□33用>	<For "-□33">	
21	SA7227101	1	ハリボウレンカンソウクミ	NEEDLE BAR CONNECTING ROD UNIT	
22	SA7625001	1	ハリボウクランク	NEEDLE BAR CRANK	
23	140004001	1	シメネジ3.57	SCREW, SM3.57-40X7	
24	SA2422001	1	シメネジ3.57L	SCREW, SM3.57L	
25	012400436	2	アナヒラ4X4	SET SCREW SOCKET (FT) M4X4	
26	SA2161001	1	ザガネ	WASHER	
27	048060342	1	トメワE6	RETAINING RING E6	
28	SA7654001	1	シメネジM3X5	SCREW M3X5	
			<-□□S用>	<For "-□□S">	
29	SA7234101	1	ハリボウレンカンソウクミ	NEEDLE BAR CONNECTING ROD UNIT	
30	SA7627001	1	ハリボウクランク	NEEDLE BAR CRANK	
31	140004001	1	シメネジ3.57	SCREW, SM3.57-40X7	
32	SA2422001	1	シメネジ3.57L	SCREW, SM3.57L	
33	012400436	2	アナヒラ4X4	SET SCREW SOCKET (FT) M4X4	
34	SA2161001	1	ザガネ	WASHER	
35	048060342	1	トメワE6	RETAINING RING E6	
36	SA7654001	1	シメネジM3X5	SCREW M3X5	
			<-453用>	<For "-453">	
37	SA7238101	1	ハリボウレンカンソウクミ	NEEDLE BAR CONNECTING ROD UNIT	
38	SA7625001	1	ハリボウクランク	NEEDLE BAR CRANK	
39	140004001	1	シメネジ3.57	SCREW, SM3.57-40X7	
40	SA2422001	1	シメネジ3.57L	SCREW, SM3.57L	
41	012400436	2	アナヒラ4X4	SET SCREW SOCKET (FT) M4X4	
42	SA2161001	1	ザガネ	WASHER	
43	048060342	1	トメワE6	RETAINING RING E6	
44	SA7654001	1	シメネジM3X5	SCREW M3X5	
45	SA7239101	1	ストッパーピン	STOPPER PIN	
46	012500536	1	アナヒラ5X5	SET SCREW SOCKET (FT) M5X5	
47	012061036	2	アナヒラ6X10	SET SCREW SOCKET (FT) M6X10	
48	102630001	1	ハリボウアンナイカクコマ	NEEDLE BAR GUIDE SLIDE BLOCK	
49	* P. 49	1	ハリボウ	NEEDLE BAR	
50	SA2194201	1	ハリボウメタルU	NEEDLE BAR BUSH U	

B. 針棒・天秤關係 / Needle bar and thread take-up mechanism

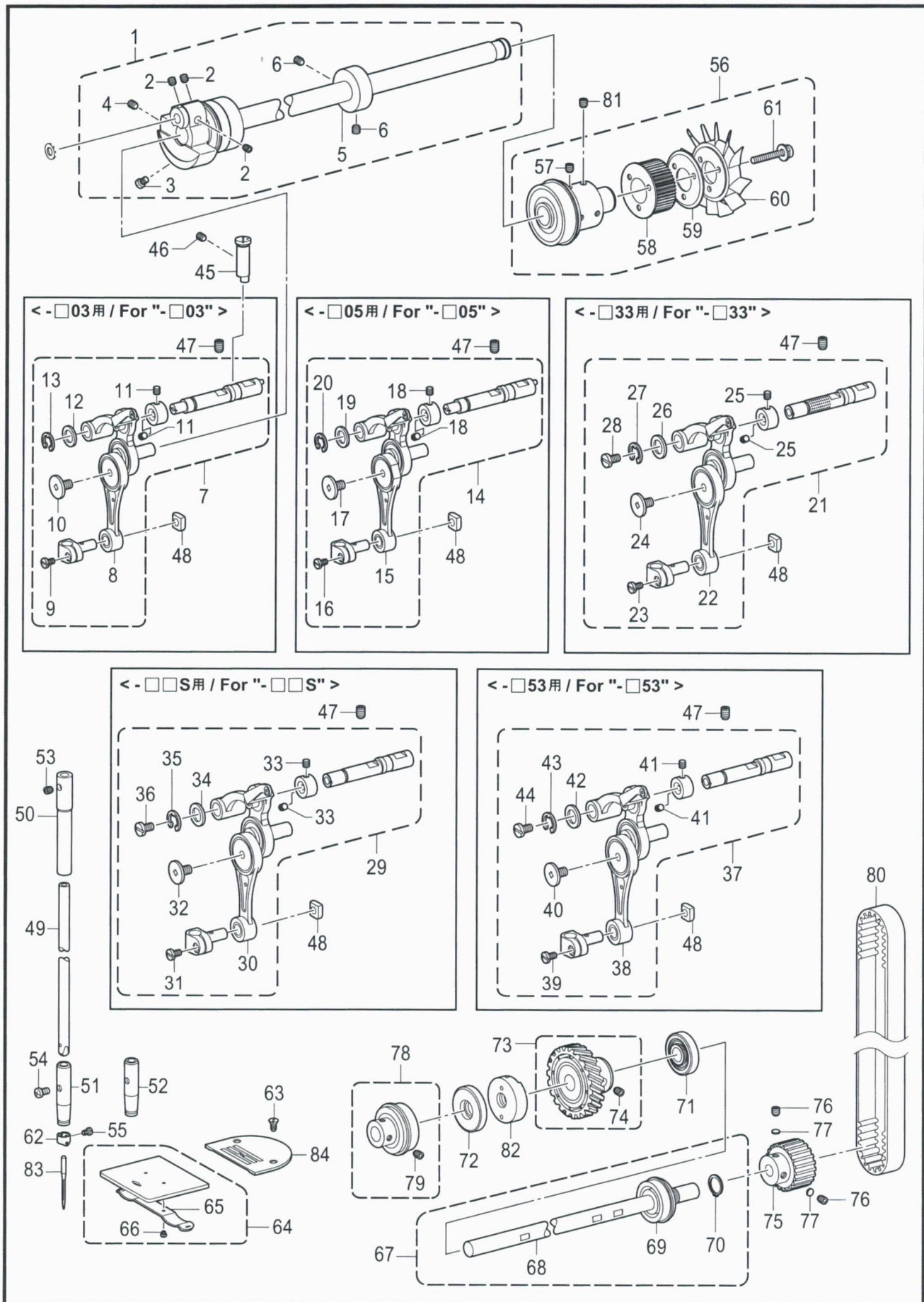

B. 針棒・天秤関係 / Needle bar and thread take-up mechanism

REF.NO	CODE	Q'TY	品名	NAME OF PARTS	RM
51	SA1138101	1	<-□□S, -□□3用> ハリボウメタルD	<For "-□□S & -□□3"> NEEDLE BAR BUSH D	
52	SA1139101	1	<-□□5用> ハリボウメタルD	<For "-□□5"> NEEDLE BAR BUSH D	
53	012500536	1	アナヒラ5X5	SET SCREW SOCKET (FT) M5X5	
54	062500616	1	ナベコ5X6	SCREW PAN M5X6	
55	140553102	1	アタマツキトメネジ3.18	SET SCREW, SM3.18	
56	SA1140001	1	ツギテソクミ	JOINT UNIT	
57	S23651001	2	アナヒラ6X6ホソメ	SET SCREW SOCKET (FT) M6X6	
58	SA2250001	1	タイミングプーリU	TIMING PULLEY, U	
59	S38712001	1	フランジ	FLANGE	
60	S38713100	1	ファン	FAN	
61	SA2404001	3	ナベザクミ4X35DB	SCREW, PAN (S WASHER) M4X35	
62	151594001	1	ハリボウイトアンナイ	NEEDL BAR THREAD GUIDE	
63	151267001	2	サラネジ4.37	SCREW, FLAT SM4.37-40X8	
64	180018151	1	スベリイタクミ	SLIDE PLATE ASSY	
65	114561001	1	スベリイタウラバネ	SPRING, PLATE	
66	122771051	2	シメネジ2.38	SCREW, SM2.38	
67	SA1143001	1	シタジククミ	LOWER SHAFT ASSY	
68	SA1144001	1	シタジク	LOWER SHAFT	
69	SA1145001	1	タマジクウケ6301ZZNR	BALL BEARING, 6301ZZNR	
70	048120142	1	トメワジクヨウC12	RETAINING RING EXTERNAL C12	
71	S25401100	1	オイルシール	OIL SEAL	
72	SA1317001	1	オイルシール	OIL SEAL	
73	SA1166001	1	シタジクギアクミ	LOWER SHAFT GEAR ASSY	
74	S23651001	2	アナヒラ6X6ホソメ	SET SCREW SOCKET (FT) M6X6	
75	SA2251001	1	タイミングプーリD	TIMING PULLEY, D	
76	S23651001	2	アナヒラ6X6ホソメ	SET SCREW SOCKET (FT) M6X6	
77	SA2378001	2	カンザ4.8	SPACER,4.8	
78	SA1150001	1	ベアリングブツシュクミ	BEARING BUSH ASSY	
79	S23651001	2	アナヒラ6X6ホソメ	SET SCREW SOCKET (FT) M6X6	
80	SA2252001	1	タイミングベルト	TIMING BELT	
81	S23651001	2	アナヒラ6X6ホソメ	SET SCREW SOCKET (FT) M6X6	
82	SA2254101	1	シタジクメタル	LOWER SHAFT BUSH	
83	* P.59	1	ハリイタ	NEEDLE PLATE	
84	* P.59	1	ミシンハリ	NEEDLE	

C . 押え関係 / Presser foot mechanism

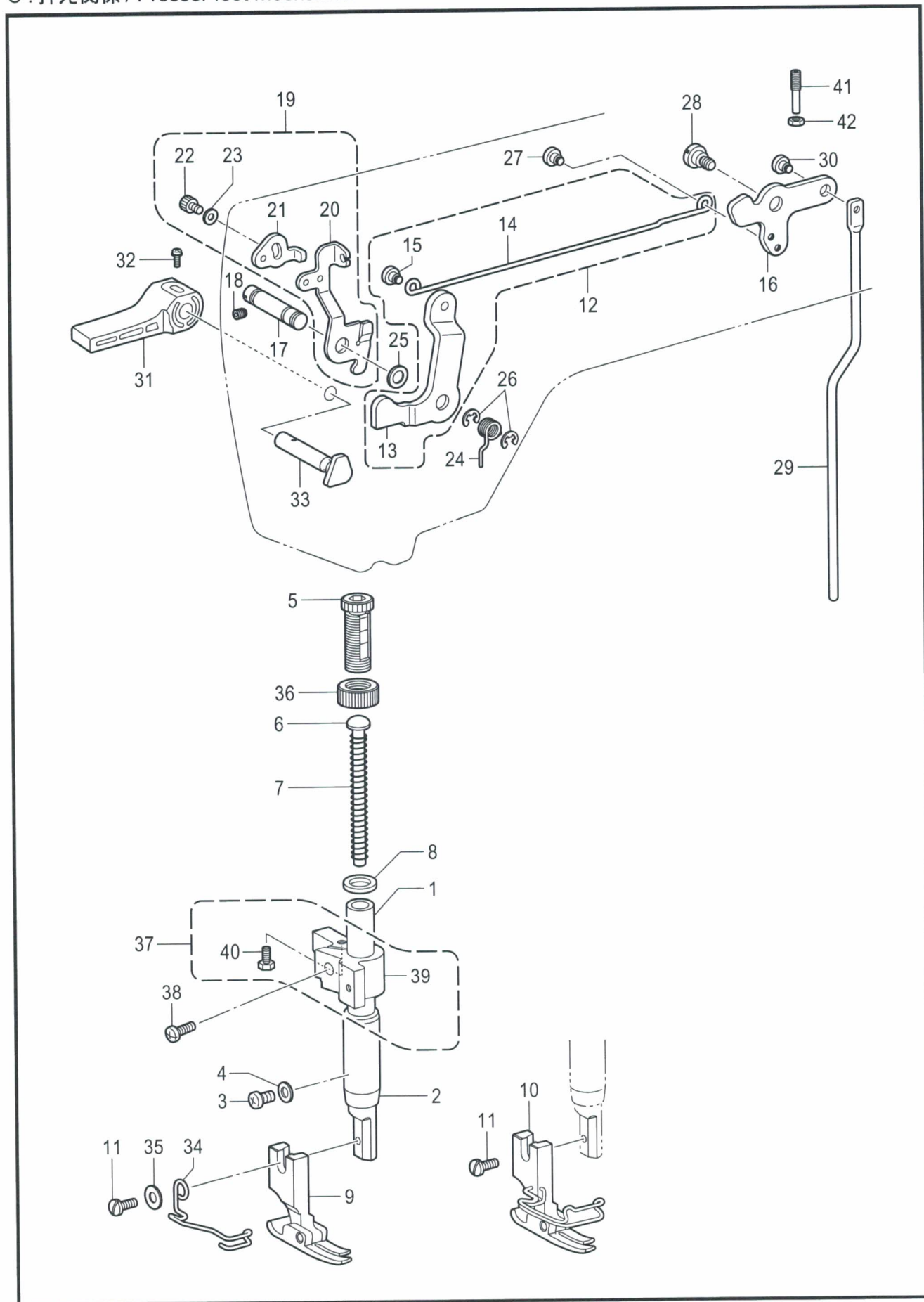

S-7200B-201

C. 押え関係 / Presser foot mechanism

REF.NO	CODE	Q'TY	品名	NAME OF PARTS	RM
1	SA1171001	1	<-□□S, -□□3用> オサエボウ	<For "-□□S & -□□3"> PRESSER BAR	
1	SA1173001	1	<-□□5用> オサエボウ	<For "-□□5"> PRESSER BAR	
2	SA7242001	1	オサエボウメタル	PRESSER BAR BUSH	
3	062500616	1	ナベコ5X6	SCREW PAN M5X6	
4	026050136	1	ヒラザガネコガタ5	WASHER PLAIN S 5	
5	SA1174001	1	オサエチヨウセツネジM14	PRESSER ADJUSTING SCREW, M14	
6	SA7607001	1	オサエバネアンナイ	SPRING GUIDE	
7	S13561101	1	<-□□3用> オサエバネ	<For "-□□3"> PRESSER BAR SPRING	
7	141728001	1	<-□□5用> オサエバネ	<For "-□□5"> PRESSER BAR SPRING	
7	147514001	1	<-□□S用> オサエバネ	<For "-□□S"> PRESSER BAR SPRING	
7	S42893001	1	<難素材用 SS> オサエバネ	<For "difficult to sew materials" SS> PRESSER BAR SPRING	
7	SA2348001	1	<難素材用 S> オサエバネ	<For "difficult to sew materials" S> PRESSER BAR SPRING	
8	140407001	1	ザガネ	WASHER	
9	153037201	1	<-□□3用> オサエクミ	<For "-□□3"> PRESSER FOOT ASSY	
10	SA2836101	1	オサエクミ	PRESSER FOOT ASSY W/F-GUARD	
9	145157101	1	<-□□5用> オサエクミ	<For "-□□5"> PRESSER FOOT ASSY	
9	150789101	1	オサエクミ	PRESSER FOOT ASSY	
10	SA2837101	1	オサエクミ	PRESSER FOOT ASSY W/F-GUARD	
9	S35777101	1	<-□□S用> オサエクミ	<For "-□□S"> PRESSER FOOT ASSY	
10	SA2433101	1	オサエクミ	PRESSER FOOT ASSY W/F-GUARD	
11	S13385001	1	シメネジ3.57X10	SCREW, SM3.57-40X10	
12	SA1176001	1	オサエアゲレバークミ	PRESSER BAR LIFTER LEVER ASSY	
13	SA1177001	1	オサエアゲレバ-	PRESSER BAR LIFTER LEVER	
14	SA1178001	1	ヒザアゲレンカン	KNEE LIFTER CONNECTING ROD	
15	SA1179001	1	ダンネジ5	SHOULDER SCREW, M5	
16	SA3980001	1	ヒザアゲレバ-	KNEE LIFTER LEVER	
17	SA1181001	1	オサエアゲレバ-ジク	PRESSER BAR LIFTER LEVER SHAFT	
18	012500536	1	アナヒラ5X5	SET SCREW SOCKET (FT) M5X5	
19	SA1182001	1	イトユルメイタクミ	TENSION RELEASE PLATE ASSY	
20	SA1183001	1	イトユルメイタ	TENSION RELEASE PLATE	
21	SA1184001	1	イトユルメリカエイタ	T-RELEASE SELECTION PLATE	
22	018400532	1	アナボルト4X5	BOLT SOCKET M4X5	
23	025040232	1	ヒラザガネチュウ4	WASHER PLAIN M 4	
24	SA1186001	1	オサエアゲレバ-バネ	P-BAR LIFTER LEVER SPRING	
25	S07350001	1	ザガネ	WASHER PLAIN	
26	048050342	2	トメワE5	RETAINING RING E5	
27	SA1179001	1	ダンネジ5	SHOULDER SCREW, M5	
28	SA2165001	1	ダンネジ6	SHOULDER SCREW, M6	
29	SA1190001	1	ヒザアゲボウ	KNEE LIFTER BAR	
30	SA1179001	1	ダンネジ5	SHOULDER SCREW, M5	
31	S31006001	1	オサエアゲテコ	LIFTING LEVER	
32	S39051001	1	ナベザクミ35X12	SCREW, PAN (S/P W) M3.5X12	
33	S45837001	1	オサエアゲクランク	PRESSER BAR LIFTER CRANK	
34	SA2778201	1	フィンガーガード	FINGER GUARD	
35	025350132	1	ヒラザガネショウ3.5	WASHER PLAIN S 3.5	
36	SA1175001	1	チヨウセツネジナツトM14	ADJUST SCREW NUT	
37	SA8005001	1	オサエボウダキクミ	PRESSER BAR GUIDE BRACKET ASSY	
38	062401216	1	ナベコ4X12	SCREW PAN M4X12	

C . 押え関係 / Presser foot mechanism

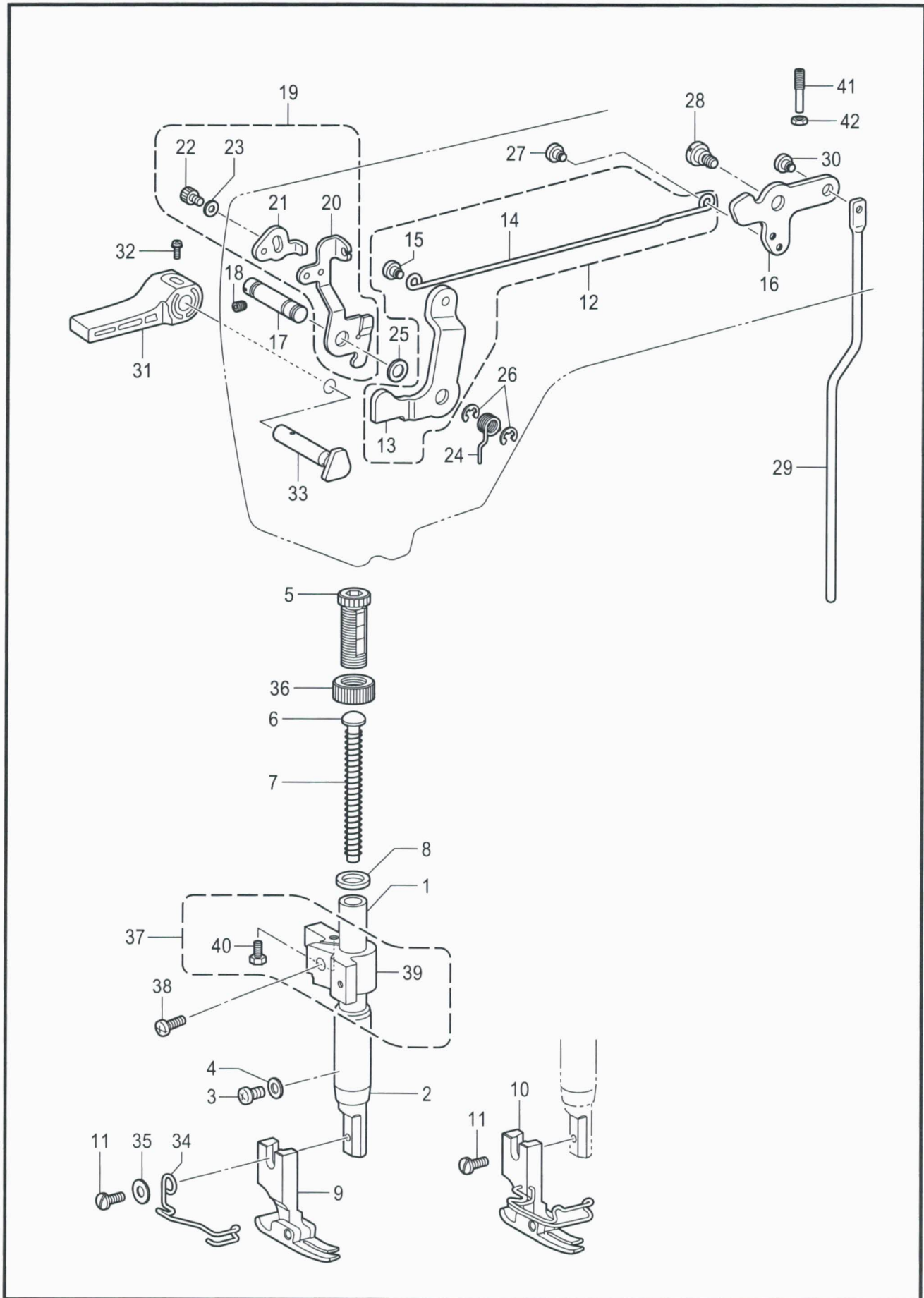

C. 押え関係 / Presser foot mechanism

REF.NO	CODE	Q'TY	品名	NAME OF PARTS	RM
39	SA8004001	1	オサエボウダキ	PRESSER BAR GUIDE BRACKET	
40	SA1193001	1	ボルト3X7.5	BOLT M3X7.5	
41	SA1189101	1	チヨウセツネジ6	ADJUSTING SCREW M6	
42	021060306	1	3シュナット6	NUT 3 M6	

D. 送り関係 / Feed mechanism

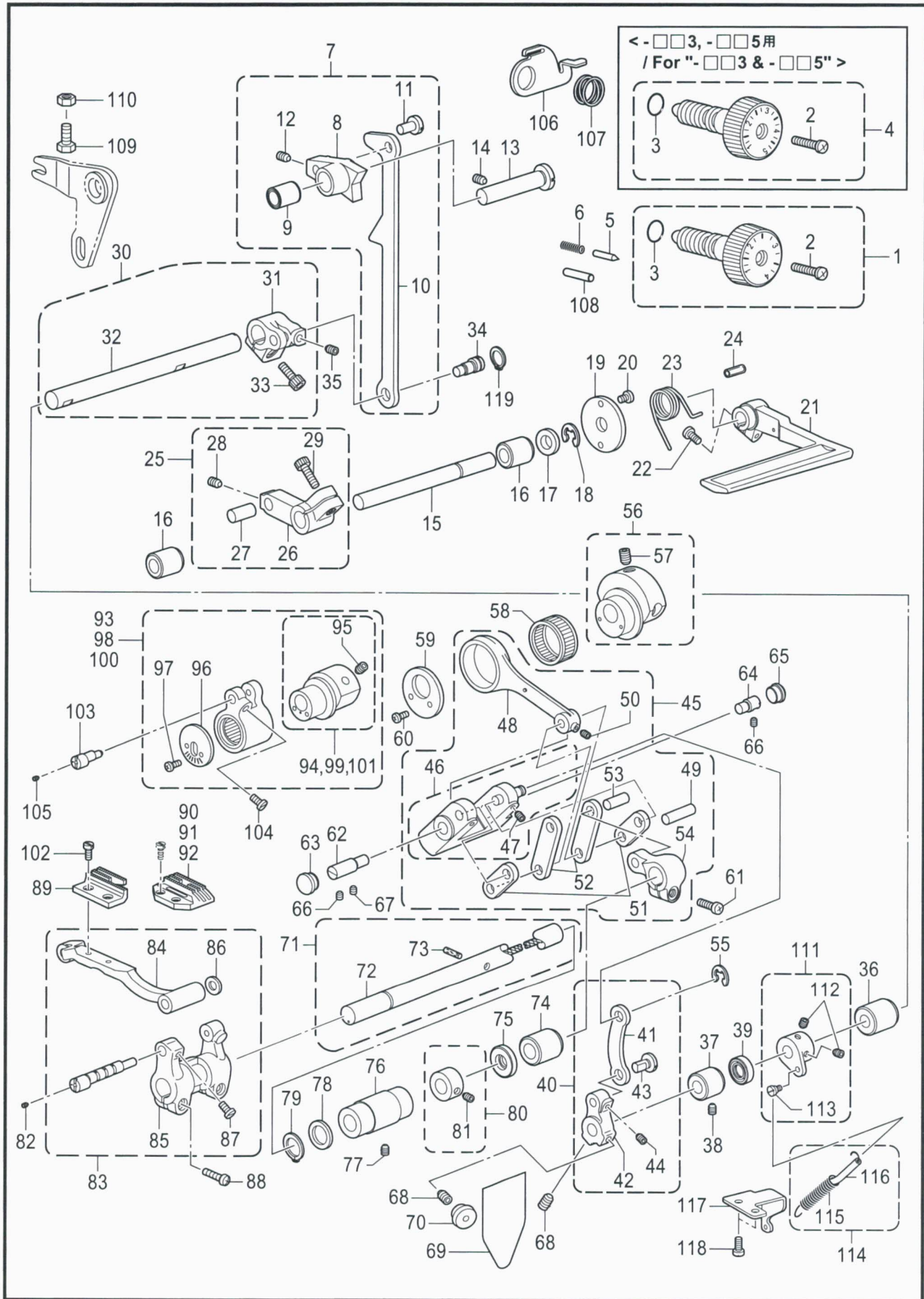

D. 送り関係 / Feed mechanism

REF.NO	CODE	Q'TY	品名	NAME OF PARTS	RM
1	SA7243001	1	<-□□3, -□□5用> オクリメモリダイヤルクミ	<For "-□□3 & -□□5"> STITCH LENGTH DIAL ASSY	
2	SA4494001	1	シメネジ4.76	SCREW SM4.76	
3	108549001	1	Oリング	O RING	
4	SA7246001	1	<-□□S用> オクリメモリダイヤルクミ	<For "-□□S"> STITCH LENGTH DIAL ASSY	
2	SA4494001	1	シメネジ4.76	SCREW SM4.76	
3	108549001	1	Oリング	O RING	
5	S50098101	1	メモリイチギメピン	POSITIONING PIN	
6	100328001	1	メモリイチギメピンバネ	NOTCH SPRING	
7	SA7249101	1	オクリチヨウセツキクミ	FEED REGULATOR ASSY	
8	SA7250101	1	オクリチヨウセツキ	FEED REGULATOR	
9	142374100	1	ドライブツシュ	BUSH DRY :L=20	
10	SA2849001	1	キリカエキレンカン	F-REGULATOR CONNECTING ROD	
11	151308102	1	レンカンジク12.5	STUD, 12.5	
12	012500536	1	アナヒラ5X5	SET SCREW SOCKET (FT) M5X5	
13	SA7635001	1	オクリチヨウセツキジク	FEED REGULATOR SHAFT	
14	012060536	2	アナヒラ6X5	SET SCREW, SOCKET (FT) M6X5	
15	SA1206001	1	カエシヌイレバージク	REVERSE SEWING SHAFT	
16	S25469100	2	ドライブツシュ	BUSH DRY :L=12	
17	025100132	1	ヒラザガネシヨウ10	WASHER PLAIN S 10	
18	048080342	1	トメワE8	RETAINING RING E8	
19	SA1207001	1	カンザ	SPACER	
20	062500816	2	ナベコ5X8	SCREW PAN M5X8	
21	SA7321001	1	カエシヌイレバー	REVERSE LEVER	
22	062501416	1	ナベコ5X14	SCREW PAN M5X14	
23	SA1209001	1	カエシヌイレバーバネ	REVERSE LEVER SPRING	
24	153132000	1	ナイロンチューブ	NYLON TUBE, L=13.5	
25	SA1210001	1	ハンドルジクウデクミ	HANDLE SHAFT ARM ASSY	
26	SA1211001	1	ハンドルジクウデ	HANDLE SHAFT ARM	
27	156958021	1	スイヘイオクリウデジク	FEED ROCK ARM SHAFT	
28	012500536	1	アナヒラ5X5	SET SCREW SOCKET (FT) M5X5	
29	018501636	1	アナボルト5X16	BOLT SOCKET M5X16	
30	SA2854001	1	キリカエキジククミ	FEED REGULATOR SHAFT ASSY	
31	SA2850101	1	キリカエキジクウデ	FEED REGULATOR SHAFT ARM	
32	SA1214101	1	キリカエキジク	FEED REGULATOR SHAFT	
33	018501436	1	アナボルト5X14	BOLT SOCKET M5X14	
34	SA2851001	1	ヘンシンピン	ECCENTRIC PIN	
35	012500536	1	アナヒラ5X5	SET SCREW SOCKET (FT) M5X5	
36	SA7252001	1	キリカエキジクメタルR	FEED REGULATOR SHAFT BUSH(R)	
37	SA7253001	1	キリカエキジクメタルL	FEED REGULATOR SHAFT BUSH(L)	
38	012060536	1	アナヒラ6X5	SET SCREW, SOCKET (FT) M6X5	
39	SA1269001	1	オイルシール	OIL SEAL	
40	SA1217101	1	キリカエキレンカンSクミ	CONNECTING ROD S ASSY	
41	S31899251	1	キリカエキレンカンS	F-REGULATOR CONNECTING ROD S	
42	SA1218001	1	キリカエキジクツギテ	FEED REGULATOR SHAFT JOINT	
43	151308102	1	レンカンジク12.5	STUD, 12.5	
44	012500536	1	アナヒラ5X5	SET SCREW SOCKET (FT) M5X5	
45	SA7323201	1	キリカエキソウクミ	FEED REGULATOR UNIT	
46	SA7324201	1	キリカエキクミ	FEED REGULATOR ASSY	
47	012500536	2	アナヒラ5X5	SET SCREW SOCKET (FT) M5X5	
48	SA1223001	1	スイヘイオクリレンカン	LEVEL FEED CONNECTING ROD	
49	SA7254001	1	リンクジク	LINK SHAFT	
50	012500536	2	アナヒラ5X5	SET SCREW SOCKET (FT) M5X5	
51	S16335001	1	スイヘイオクリリンククミ	LEVEL FEED LINK ASSY	
52	S16337001	1	スイヘイオクリウデリンククミ	FEED ROCKER ARM LINK ASSY	
53	156958021	1	スイヘイオクリウデジク	FEED ROCK ARM SHAFT	
54	SA1225001	1	スイヘイオクリウデ	FEED ROCK ARM	
55	048040342	1	トメワE4	RETAINING RING E4	

D. 送り関係 / Feed mechanism

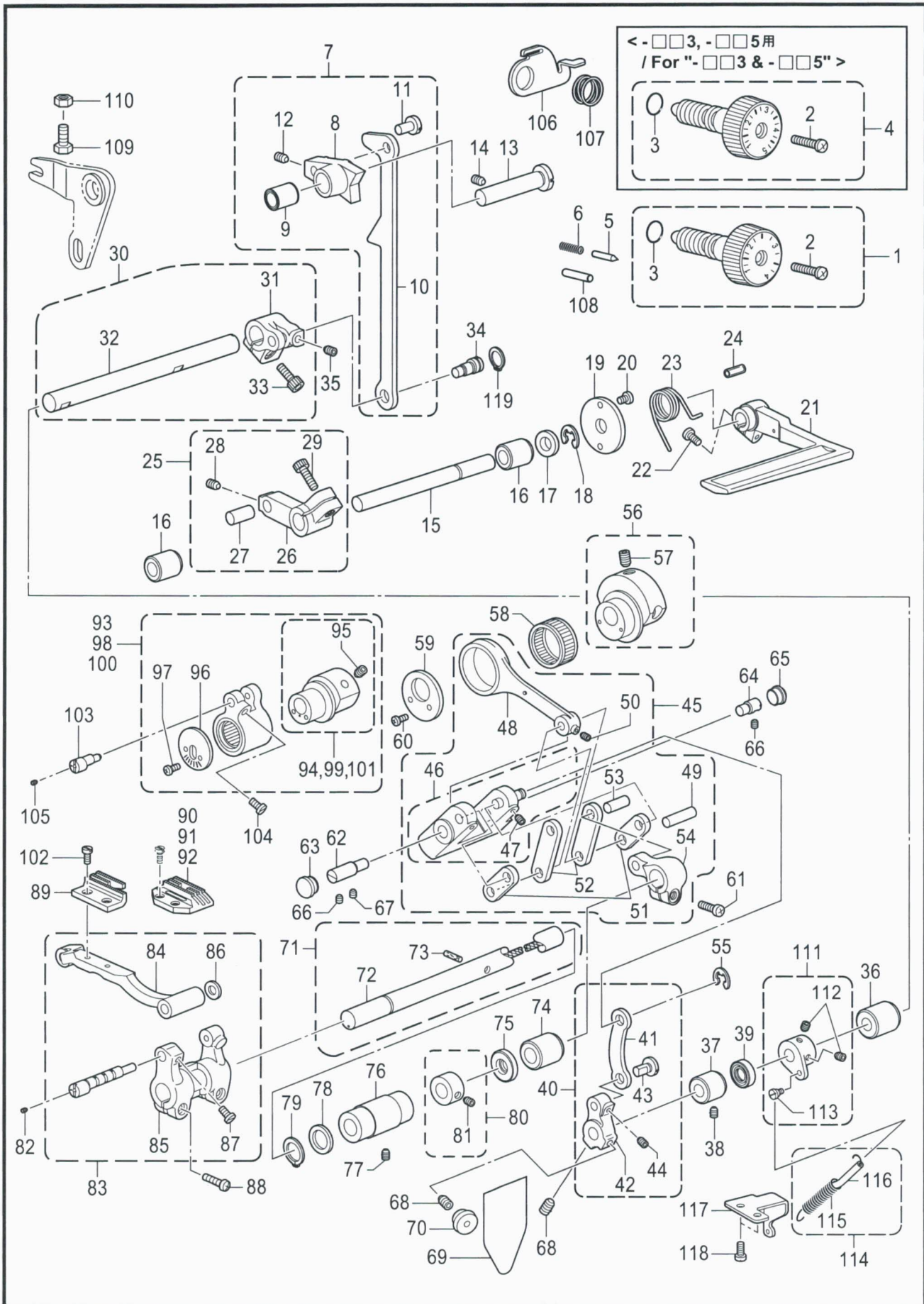

D. 送り関係 / Feed mechanism

REF.NO	CODE	Q'TY	品名	NAME OF PARTS	RM
56	SA1263001	1	<-□□3, -□□5用> スイハイヘンシンリンネジツキ	<For "-□□3 & -□□5"> ECCENTRIC WHEEL, W/SCREW	
57	S25236001	2	アナヒラ6X10ホソメ	SET SCREW SOCKET (FT) M6X10	
56	SA1261001	1	<-□□S用> スイハイヘンシンリンネジツキ	<For "-□□S"> ECCENTRIC WHEEL, W/SCREW	
57	S25236001	2	アナヒラ6X10ホソメ	SET SCREW SOCKET (FT) M6X10	
58	S12915001	1	ニードルジクウケ25	ROLLER BEARING, RADIAL 25 :RED	
59	S25321001	1	レンカンオサエ	HOLDER	
60	062350616	2	ナベコ35X6	SCREW PAN M3.5X6	
61	062501416	1	ナベコ5X14	SCREW PAN M5X14	
62	SA1226101	1	キリカエジクL	FEED REGULATOR SHAFT, L	
63	104449001	1	ゴムセン15.5	RUBBER CAP, 15.5	
64	SA1227101	1	キリカエキササエジク	FEED REGULATOR SUPPORT SHAFT	
65	SA1228001	1	ゴムセン14.5	RUBBER CAP, 14.5	
66	012060536	2	アナヒラ6X5	SET SCREW, SOCKET (FT) M6X5	
67	SA1229101	1	アナトメネジ6トガリ	SET SCREW (FT) M6X6	
68	S23651001	2	アナヒラ6X6ホソメ	SET SCREW SOCKET (FT) M6X6	
69	SA2377001	1	ゴムセンラベル	RUBBER CAP LABEL	
70	S34352101	1	ゴムセン13.5	RUBBER CAP, 13.5	
71	SA1230001	1	スイハイオクリジククミ	FEED ROCK SHAFT ASSY	
72	SA1231001	1	スイハイオクリジク	FEED ROCK SHAFT	
73	SA2162001	1	フェルト	FELT	
74	SA7255001	1	オクリジクメタルR	FEED SHAFT BUSH(R)	
75	SA1237001	1	オイルシール	OIL SEAL	
76	SA1233101	1	オクリジクメタルL	FEED SHAFT BUSH L	
77	012060536	1	アナヒラ6X5	SET SCREW, SOCKET (FT) M6X5	
78	156243021	1	オクリジクスラストリング	THRUST RING	
79	048150142	1	トメワジクヨウC15	RETAINING RING EXTERNAL C15	
80	SA1234001	1	セットカラークミ	SET SCREW COLLAR	
81	S23651001	2	アナヒラ6X6ホソメ	SET SCREW SOCKET (FT) M6X6	
82	014300432	1	アナクボミ3X4	SET SCREW SOCKET (CP) M3X4	
83	SA1238401	1	オクリダイクミ	FEED BAR ASSY	
84	SA1239201	1	オクリダイ	FEED BAR	
85	SA7330001	1	スイハイオクリダイウデ	FEED ROCK BRACKET ARM	
86	158722001	1	ザガネ4.2	WASHER PLAIN 4.2	
87	SA1242001	1	アタマトメクボミ5X7	SET SCREW 5X7	
88	SA7257001	2	シメネジ5X12	SCREW 5X12	
89	S02742001	1	<-□□3用> オクリバ	<For "-□□3"> FEED DOG	
90	SA2345001	1	オクリバ	FEED DOG	
89	S02743001	1	<-□□5用> オクリバ	<For "-□□5"> FEED DOG	
90	150793001	1	オクリバ	FEED DOG	
91	S02748001	1	<-□□S用> オクリバAB	<For "-□□S"> FEED DOG, AB	
92	SA2346001	1	オクリバ	FEED DOG	

D. 送り関係 / Feed mechanism

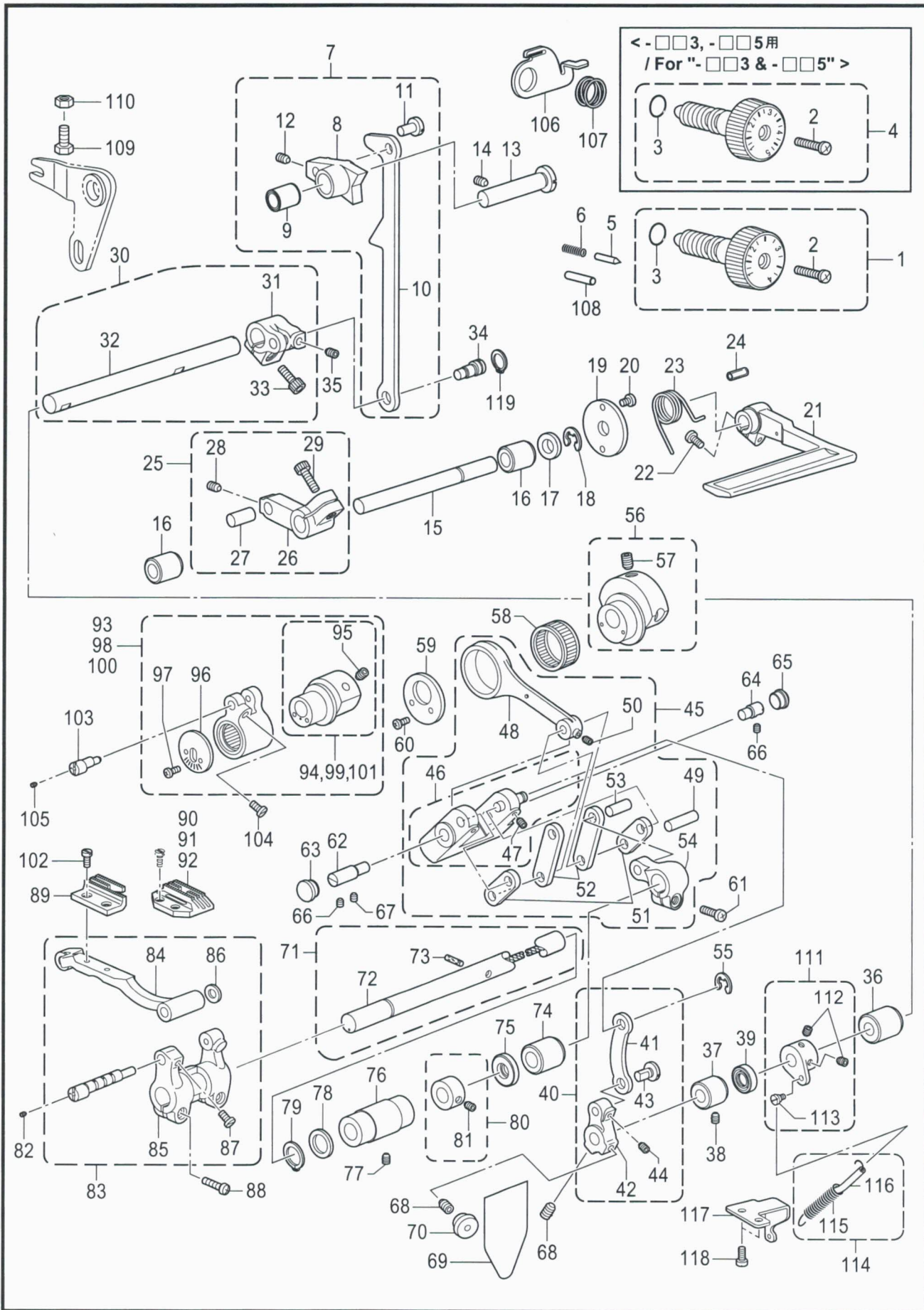

D. 送り関係 / Feed mechanism

REF.NO	CODE	Q'TY	品名	NAME OF PARTS	RM
			<-□□3用>	<For "-□□3">	
93	SA1245101	1	ジョウゲヘンシンリンクミ	F-LIFTING ECCENTRIC WHEEL ASSY	
94	SA1247001	1	ヘンシンリンネジツキ	ECCENTRIC WHEEL, W/SCREW	
95	S25236001	2	アナヒラ6X10ホソメ	SET SCREW SOCKET (FT) M6X10	
96	S25339201	1	オクリダイウデオサエ	FEED BAR ARM PRESSER	
97	062300616	2	ナベコ3X6	SCREW PAN M3X6	
			<-□□S用>	<For "-□□S">	
98	SA1253101	1	ジョウゲヘンシンリンクミ	F-LIFTING ECCENTRIC WHEEL ASSY	
99	SA1254001	1	ヘンシンリンネジツキ	ECCENTRIC WHEEL W/SCREW	
95	S25236001	2	アナヒラ6X10ホソメ	SET SCREW SOCKET (FT) M6X10	
96	S25339201	1	オクリダイウデオサエ	FEED BAR ARM PRESSER	
97	062300616	2	ナベコ3X6	SCREW PAN M3X6	
			<-□□5用>	<For "-□□5">	
100	SA1250101	1	ジョウゲヘンシンリンクミ	F-LIFTING ECCENTRIC WHEEL ASSY	
101	SA1251001	1	ヘンシンリンネジツキ	ECCENTRIC WHEEL W/SCREW	
95	S25236001	2	アナヒラ6X10ホソメ	SET SCREW SOCKET (FT) M6X10	
96	S25339201	1	オクリダイウデオサエ	FEED BAR ARM PRESSER	
97	062300616	2	ナベコ3X6	SCREW PAN M3X6	
102	100080004	2	シメネジ3.18	SCREW, SM3.18-44X6.5	
103	SA2401001	1	ジョウゲオクリジクオオクミ	LIFTING FEED SHAFT UNINT	
104	SA1242001	1	アタマトメクボミ5X7	SET SCREW 5X7	
105	014300432	1	アナクボミ3X4	SET SCREW SOCKET (CP) M3X4	
106	S47508101	1	ダイヤルロックレバー	DIAL LOCK LEVER	
107	S39830101	1	ダイヤルロックレバーバネ	SPRING	
108	SA7422001	1	ロックレバーピン	ROCK LEVER PIN	
109	SA2347001	1	ボルト5X16	BOLT M5X16	
110	021500316	1	3シュナット5	NUT 3 M5	
111	SA2295201	1	バネカケウデクミ	SPRING HOOK ARM ASSY	
112	S23651001	2	アナヒラ6X6ホソメ	SET SCREW SOCKET (FT) M6X6	
113	S25427101	1	ダンネジ4	SHOULDER SCREW, M4	
114	SA3152001	1	ヒキバネクミ	SPRING ASSY	
115	SA2294101	1	ヒキバネ	SPRING	
116	SA3114001	1	ビニルチューブ	VINYL TUBE	
117	SA2293101	1	バネトリツケイタ	SPRING SET PLATE	
118	062500816	2	ナベコ5X8	SCREW PAN M5X8	
119	048100142	1	トメワジクヨウC10	RETAINING RING EXTERNAL C10	

E . 膝上げ関係 / Knee lifter mechanism

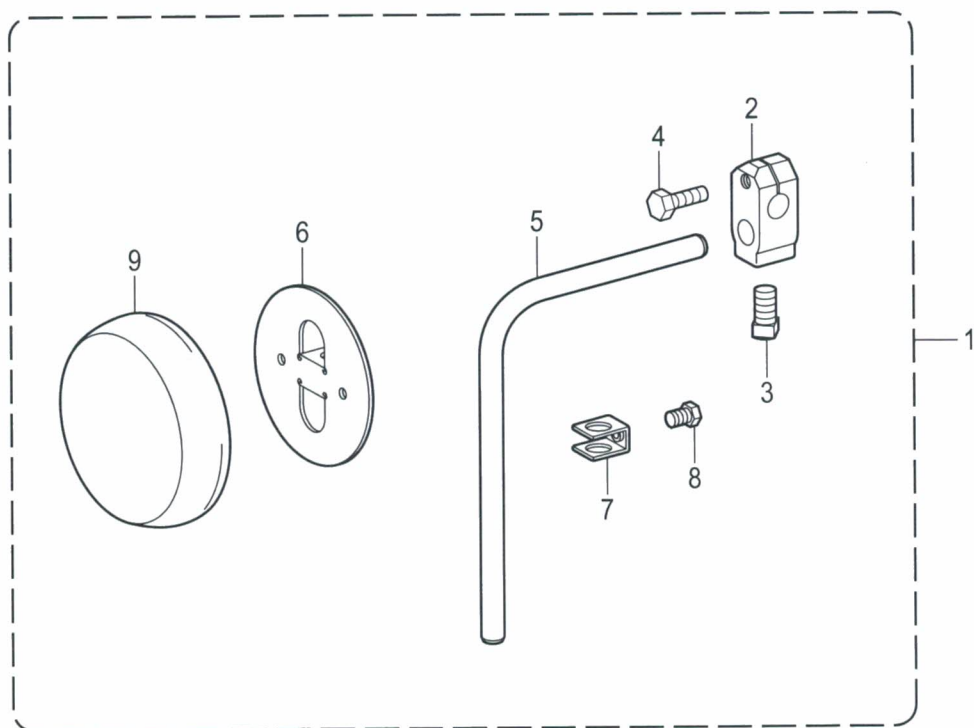

E. 膝上げ関係 / Knee lifter mechanism

REF.NO	CODE	Q'TY	品名	NAME OF PARTS	RM
1	S35821021	1	ヒザアテクミ	KNEE LIFTER ASSY	
2	146039021	1	ヒザアテツギテ	KNEE LIFTER BRACKET	
3	100463021	1	4カクボルト7.94	BOLT, SQUARE SM7.94	
4	S35820021	1	ボルト5.95X20	BOLT, SM5.95X20	
5	104619022	1	ヒザアゲタテジク	KNEE LIFTER BAR	
6	S34756021	1	ヒザアテ	KNEE LIFTER PLATE	
7	114967021	1	ヒザアテストップパ	KNEE LIFTER PLATE STOPPER	
8	110087021	1	ボルト5.95	BOLT, SM5.95-28X8	
9	S31885001	1	ヒザアテカバー	KNEE LIFTER PLATE COVER	

F. 逆転関係 / Quick reverse mechanism

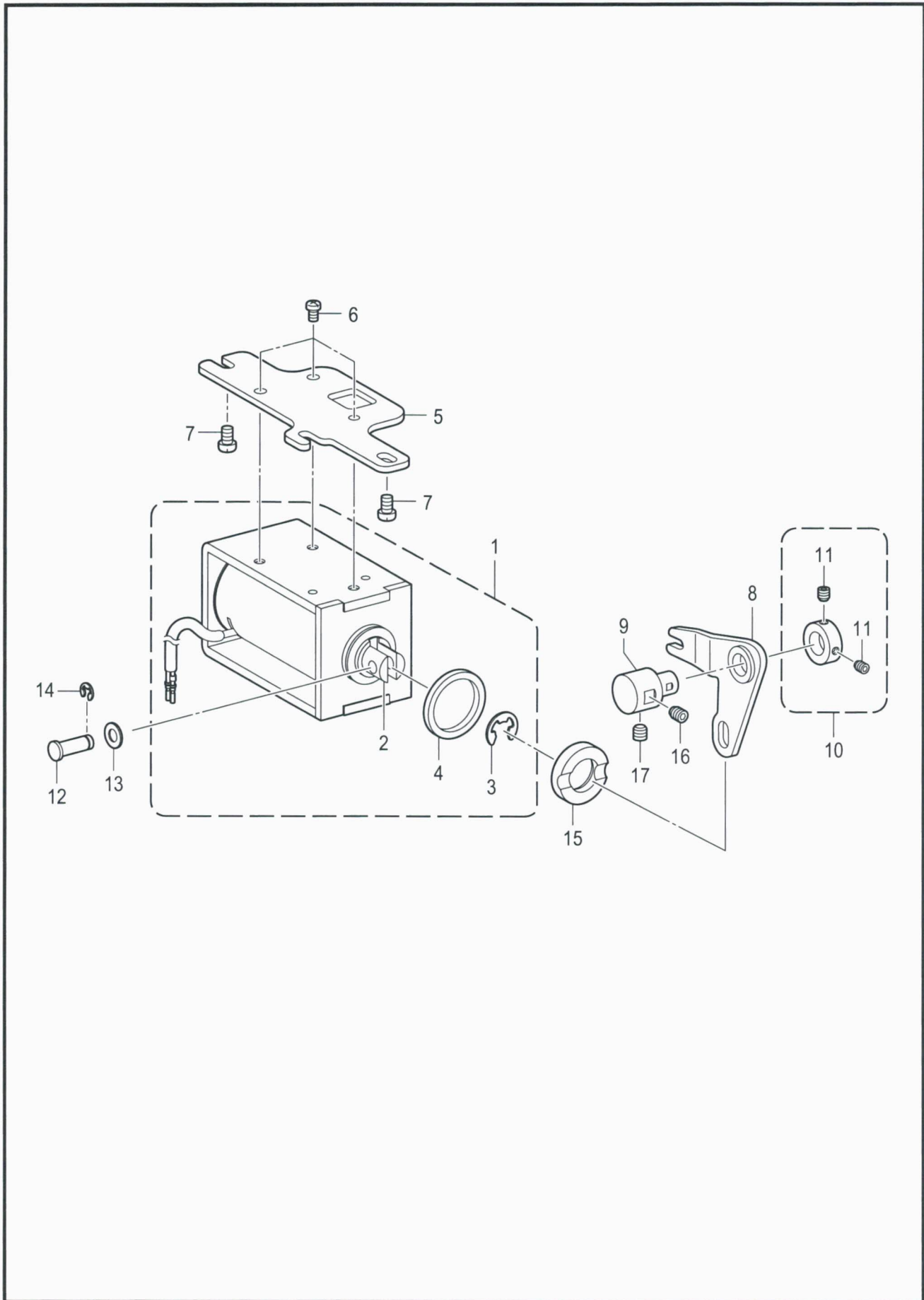

S-7200B-205

F. 逆転関係 / Quick reverse mechanism

REF.NO	CODE	QTY	品名	NAME OF PARTS	RM
1	SA1399201	1	ギヤクテンソレノイドクミ	QUICK REVERSE SOLENOID ASSY	
2	154729001	1	プランジャ	PLUNGER	
3	154730001	1	トメワE15	RETAINING RING E15	
4	154731000	1	ゴムストツパー	RUBBER STOPPER	
5	SA1258001	1	ソレノイドダイ	SOLENOID BASE	
6	062500816	3	ナベコ5X8	SCREW PAN M5X8	
7	062061016	2	ナベコ6X10	SCREW PAN M6X10	
8	SA2852001	1	ソレノイドレバー	SOLENOID LEVER	
9	SA2844101	1	ソレノイドレバージク	SOLENOID LEVER SHAFT	
10	SA2848001	1	セットカラークミ	SET COLLAR ASSY	
11	012500536	2	アナヒラ5X5	SET SCREW SOCKET (FT) M5X5	
12	SA2992001	1	レンケツピン	PIN	
13	153138001	1	ザガネ	WASHER, PLAIN 6.5	
14	048060142	1	トメワジクヨウC6	RETAINING RING EXTERNAL C6	
15	SA2286001	1	ゴムクッション	RUBBER CUSHION	
16	012060536	1	アナヒラ6X5	SET SCREW, SOCKET (FT) M6X5	
17	012500536	1	アナヒラ5X5	SET SCREW SOCKET (FT) M5X5	

G . かま関係 / Rotary hook mechanism

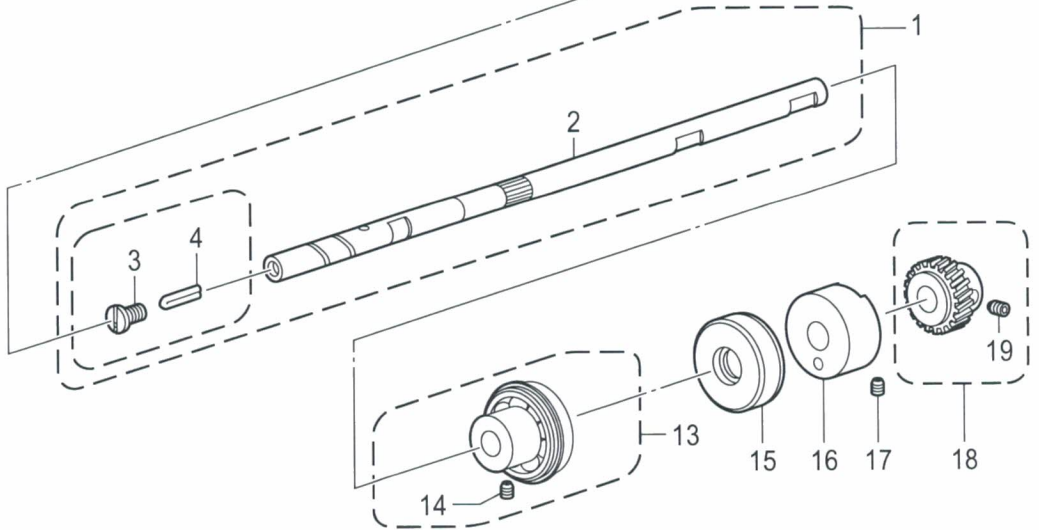
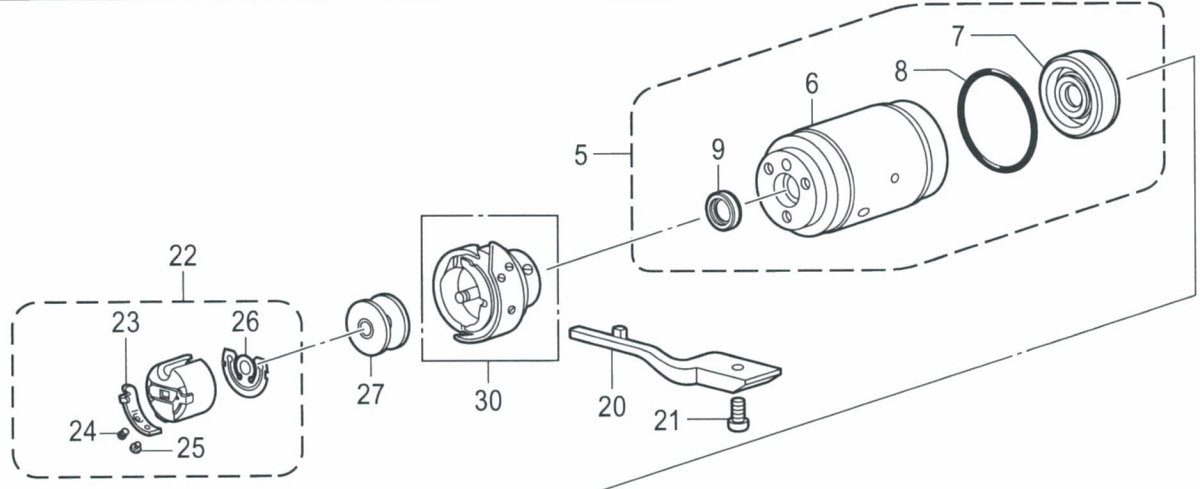
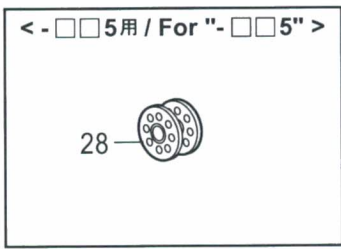
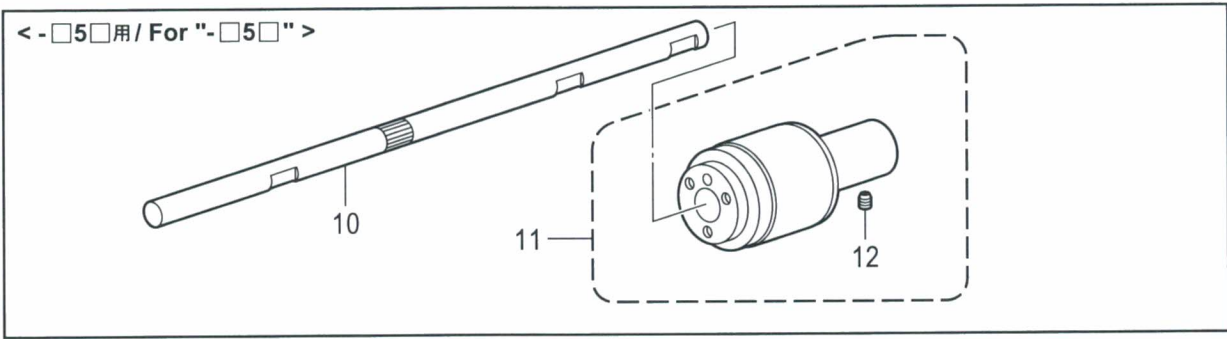

G. かま関係 / Rotary hook mechanism

REF.NO	CODE	Q'TY	品名	NAME OF PARTS	RM
			<-□□S, -□□3, -□□5用>	<For "-□□S, -□□3 & -□□5">	
1	SA7261101	1	カマジククミ	ROTARY HOOK SHAFT ASSY	
2	SA7262001	1	カマジク	ROTARY HOOK SHAFT	
3	SA7148001	1	オイルアナフタネジ	SCREW CAP W/HOLE M5-0.8	
4	SA7525001	1	フェルト	FELT	
5	SA7263301	1	ポンプメタルオオクミ	PUMP BUSH UNIT	
6	SA7879001	1	ポンプメタルクミ	PUMP BUSH ASSY	
7	SA7693001	1	オイルシール	OIL SEAL	
8	081025870	1	OリングS25	O RING S25	
9	SA7320001	1	オイルシール	OIL SEAL	
			<-□5□用>	<For "-□5□">	
10	SA1273001	1	カマジク	ROTARY HOOK SHAFT	
11	SA7266001	1	カマメタルソウクミ	ROTARY HOOK UNIT	
12	S23651001	2	アナヒラ6X6ホソメ	SET SCREW SOCKET (FT) M6X6	
13	SA7554001	1	ベアリングブツシュクミ	BEARING BUSH ASSY	
14	S23651001	2	アナヒラ6X6ホソメ	SET SCREW SOCKET (FT) M6X6	
15	SA1284001	1	オイルシール	OIL SEAL	
16	SA1285001	1	カマジクギヤメタル	ROTARY HOOK SHAFT GEAR BUSH	
17	012060536	1	アナヒラ6X5	SET SCREW, SOCKET (FT) M6X5	
18	SA1286001	1	カマジクギアクミ	ROTARY HOOK SHAFT GEAR ASSY	
19	S23651001	2	アナヒラ6X6ホソメ	SET SCREW SOCKET (FT) M6X6	
			<-□□S, -□□3用>	<For "-□□S, -□□3">	
20	S02602001	1	ウチカマトメ	HOOK STOPPER	
			<-□□5用>	<For "-□□5">	
20	159324001	1	ウチカマトメ	HOOK STOPPER	
21	062401216	1	ナベコ4X12	SCREW PAN M4X12	
22	S03245001	1	ボビンケースクミ	BOBBIN CASE ASSY	
23	183388001	1	ボビンケースチヨウシバネ	TENSION SPRING	
24	183389001	1	チヨウシバネチヨウセツネジ	ADJUSTING SCREW	
25	183390001	1	チヨウシバネトメネジ	SET SCREW	
26	S03246001	1	クウテンボウシバネ	ANTI-SPIN SPRING	
			<-□□S, -□□3用>	<For "-□□S & -□□3">	
27	146290001	1	ボビン	BOBBIN	
			<-□□5用>	<For "-□□5">	
28	117132001	1	ボビン	BOBBIN	
			"補給用部品"	"For supply parts "	
			<-□5S, -□53用>	<For "-□5S, -□53">	
29	SA2875001		SA2876ウチカマハコクミ	I-ROTARY HOOK , W/BOX SA2876	
30	* P. 59	1	カマハコクミ	ROTARY HOOK ASSY W/BOX	

H. 給油潤滑関係 / Lubrication

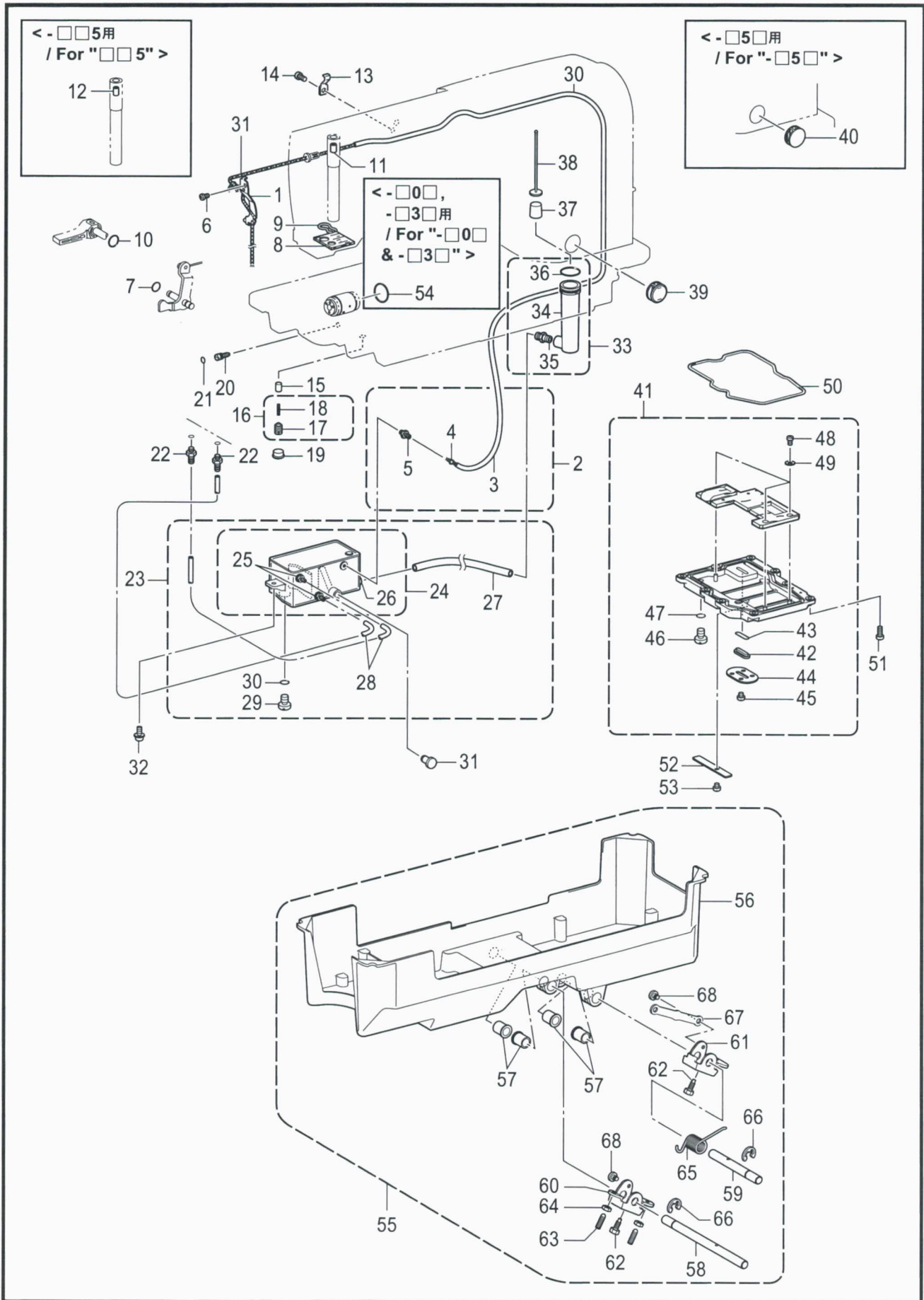

H. 給油潤滑関係 / Lubrication

REF.NO	CODE	Q'TY	品名	NAME OF PARTS	RM
			<-□0□用>	<For "-□0□">	
1	SA1292001	1	トウシンホルダ-クミ	WICK HOLDER ASSY	
2	SA2343001	1	ビニルチューブクミ	OIL TUBU ASSY	
3	SA1304001	1	ビニルチューブ	VINYL TUBE	
4	SA1305001	1	クミヒモ	WICK	
5	S25382001	1	オイルクチ	OIL FEEDING PIPE	
6	062500616	1	ナベコ5X6	SCREW PAN M5X6	
7	081004070	1	OリングP4	O RING P4	
8	S38769000	1	フェルト	FELT	
9	145737001	1	フェルトオサエ	FELT SUPPORT	
10	081004070	1	OリングP4	O RING P4	
			<-□□S, -□□3用>	<For "-□□S & -□□3">	
11	S04630000	1	ハリボウセン	NEEDLE BAR CORK	
			<-□05用>	<For "-□05">	
12	111863001	1	ハリボウセン	NEEDLE BAR CORK	
			<-□0□用>	<For "-□0□">	
13	SA1295001	1	コードオサエT2	CORD HOLDER, T2	
14	062500816	1	ナベコ5X8	SCREW PAN M5X8	
			<-□0□, -□3□用>	<For "-□0□ & -□3□">	
15	144875001	1	プランジャー	PLUNGER	
16	SA7636001	1	ポンプフタネジクミ	PUMP CAP SCREW ASSY	
17	S25380401	1	ポンプフタネジ	CAP SCREW, PUMP	
18	S52764001	1	プランジャーバネ	SPRING, COMPRESSION	
19	104821001	1	ゴムセン10.5	RUBBER CAP, 10.5	
20	SA7265101	1	オイルチヨウセツネジ	ADJUSTING SCREW	
21	081004870	1	OリングS4	O RING S4	
22	S25382001	2	オイルクチ	OIL FEEDING PIPE	
23	SA7345101	1	オイルタンクソウクミ	OIL TANK UNIT	
24	SA3158101	1	オイルタンククミ	OIL TANK ASSY	
25	S25382001	2	オイルクチ	OIL FEEDING PIPE	
26	S51815001	1	オイルクチ8.6	OIL FEEDING PIPE, 8.6	
27	SA1300001	1	ビニルチューブ	VINYL TUBE	
28	SA7269001	2	ビニルチューブ	VINYL TUBE	
29	SA1303001	1	シメネジ8	SCREW M8	
30	081008070	1	OリングP8	O RING P8	
31	104450101	1	ゴムセン8	RUBBER CAP, 8	
32	0A4501206	2	+ナベザクミ5X12DA	SCREW PAN (S/P WASHER) M5X12	
33	SA1306001	1	サブタンククミ	SUB TANK ASSY	
34	SA1307001	1	サブタンク	SUB TANK	
35	S51815001	1	オイルクチ8.6	OIL FEEDING PIPE, 8.6	
36	081022870	1	OリングS22	O RING S22	
37	S47487001	1	オイルゲ-ジウキ	FLOAT	
38	SA1309001	1	オイルゲ-ジ	OIL GAGE	
39	S47509001	1	ユリヨウケイマド	OIL GAUGE WINDOW	
			<-□5□用>	<For "-□5□">	
40	SA2779001	1	ユリヨウケイマド	OIL GAUGE WINDOW	
41	SA4552001	1	ベッドソコフタソウクミ	BED BOTTOM COVER UNIT	
42	S51272100	1	ソコフタマド	OIL WINDOW, B-COVER	
43	081015870	1	OリングS15	O RING S15	
44	SA1313101	1	マドフタ	WINDOW COVER	
45	062500616	4	ナベコ5X6	SCREW PAN M5X6	
46	SA1303001	1	シメネジ8	SCREW M8	
47	081008070	1	OリングP8	O RING P8	
48	062400616	3	ナベコ4X6	SCREW PAN M4X6	
49	025040332	3	ヒラザガネダイ4	WASHER PLAIN L 4	
50	SA1314001	1	ソコフタパツキン	BOTTOM COVER PACKING	
51	062501216	9	ナベコ5X12	SCREW PAN M5X12	
52	SA1316001	1	コードオサエイタ	CORD HOLDER PLATE	
53	062500616	1	ナベコ5X6	SCREW PAN M5X6	

H. 給油潤滑関係 / Lubrication

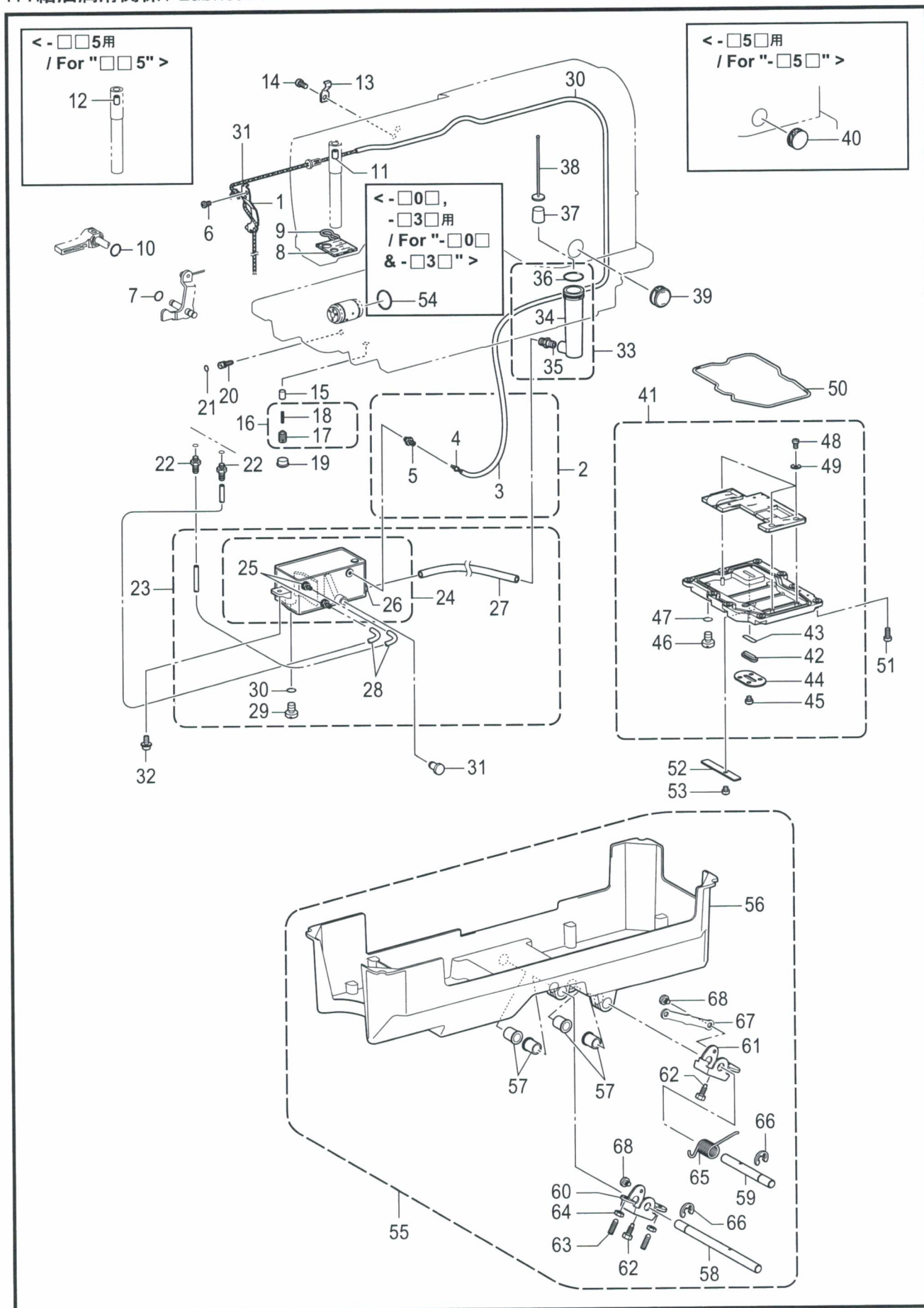

H. 給油潤滑関係 / Lubrication

REF.NO	CODE	Q'TY	品名	NAME OF PARTS	RM
54	081029870	1	<-□0□, -□3□用> OリングS29	<For "-□0□ & -□3□"> O RING S29	
55	SA1321401	1	オイルパンクミ	OIL PAN	
56	SA1322301	1	オイルパン	OIL PAN	
57	149578000	4	ヨコジクブツシュ	BUSH	
58	SA1323001	1	ヒザアゲヨコジクL	KNEE LIFTER SHAFT L	
59	SA1324001	1	ヒザアゲヨコジクR	KNEE LIFTER SHAFT R	
60	SA1325001	1	ヒザアゲ	KNEE LIFTER	
61	SA1326101	1	ヒザアゲR	KNEE LIFTER, R	
62	S25344001	2	ボルト6	BOLT M6	
63	S25475101	2	トメネジ6	SET SCREW, M6X19	
64	021060306	2	3シュナット6	NUT 3 M6	
65	SA3508001	1	ヒザアゲネジリバネ	TWIST SPRING	
66	146293001	2	トメワE10	RETAINING RING, E10	
67	SA1327101	1	ヒザアゲレンケツカン	KNEE LIFTER CONNECTING ROD	
68	SA1179001	2	ダンネジ5	SHOULDER SCREW, M5	

J. 糸通し関係 / Threading mechanism

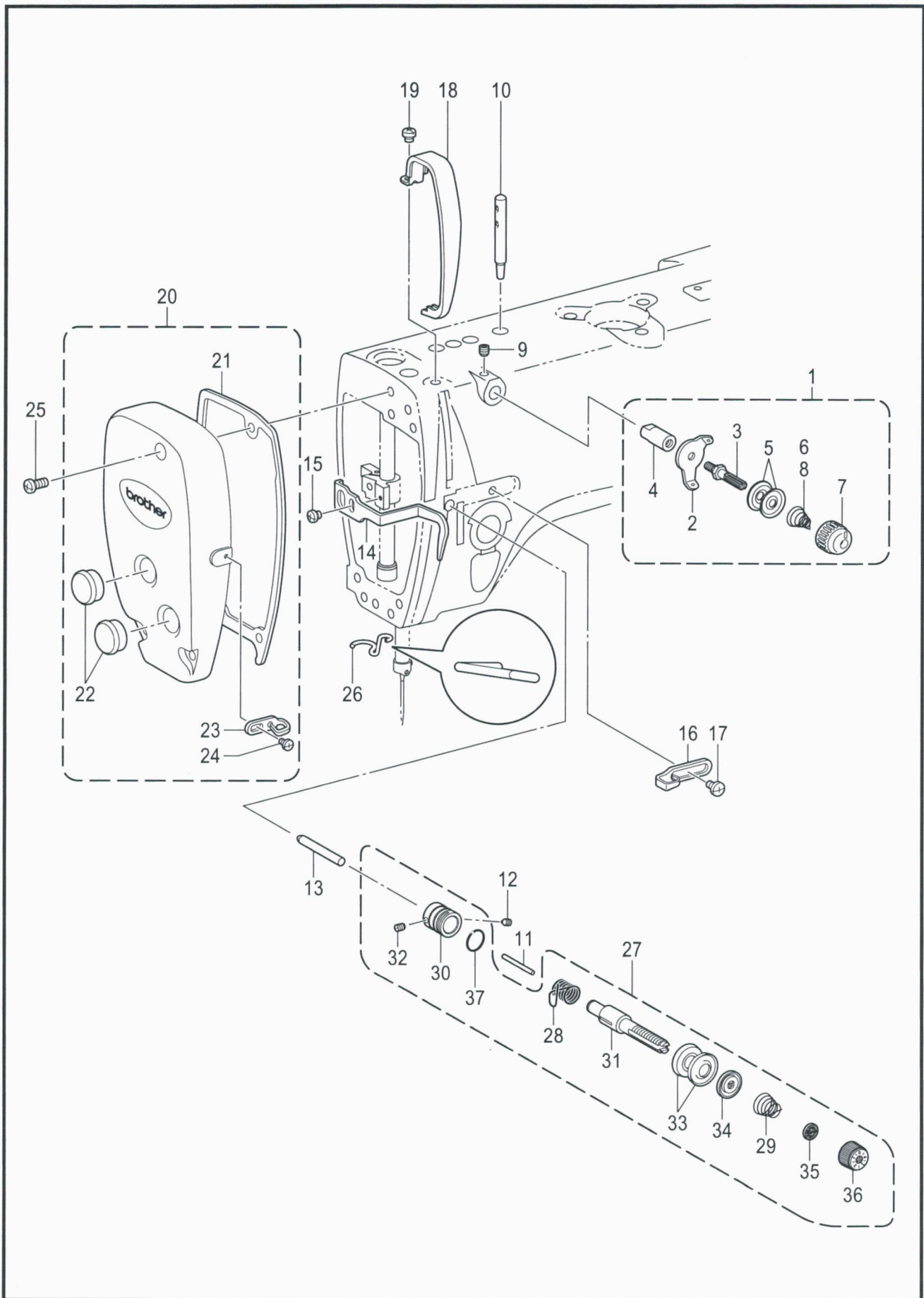

J. 糸通し関係 / Threading mechanism

REF.NO	CODE	Q'TY	品名	NAME OF PARTS	RM
			<-□□S用>	<For "-□□S">	
1	SA2351101	1	プレテンションクミA	PRE-TENSION ASSY A	
2	SA2362001	1	イトアンナイ	THREAD GUIDE	
3	S45563001	1	イトアンナイチヨウシボウ	THREAD GUIDE TENSION STUD	
4	SA2363001	1	プレテンションダイ	PRE-TENSION BASE	
5	144504001	2	イトアンナイサラ	THREAD GUIDE DISC	
6	SA2356101	1	プレテンションバネA	PRE-TENSION SPRING A	
7	SA6167001	1	イトチヨウシナット	THREAD TENSION NUT	
			<-□□3, -□□5用>	<For "-□□3 & -□□5">	
1	SA2352101	1	プレテンションクミB	PRE-TENSION ASSY B	
2	SA2362001	1	イトアンナイ	THREAD GUIDE	
3	S45563001	1	イトアンナイチヨウシボウ	THREAD GUIDE TENSION STUD	
4	SA2363001	1	プレテンションダイ	PRE-TENSION BASE	
5	144504001	2	イトアンナイサラ	THREAD GUIDE DISC	
8	SA2358101	1	プレテンションバネB	PRE-TENSION SPRING B	
7	SA6167001	1	イトチヨウシナット	THREAD TENSION NUT	
9	012500536	1	アナヒラ5X5	SET SCREW SOCKET (FT) M5X5	
10	SA1359001	1	イトタテボウ	SPOOL PIN	
11	S01419000	1	イトユルメピン	TENSION RELEASE PIN	
12	SA1229101	1	アナトメネジ6トガリ	SET SCREW (FT) M6X6	
13	SA1343001	1	イトユルメボウ	TENSION RELEASE STUD	
14	SA2417001	1	オサエボウダキイトアンナイ	THREAD GUIDE, P-BAR BRACKET	
15	062400816	1	ナベコ4X8	SCREW PAN M4X8	
16	SA1345001	1	ア-ムイトアンナイR	ARM THREAD GUIDE, R	
17	060500616	1	バインド5X6	SCREW BIND M5X6	
18	SA1342001	1	テンビンカバー	THREAD TAKE-UP LEVER COVER	
19	062500616	1	ナベコ5X6	SCREW PAN M5X6	
20	SA1961101	1	メンイタクミ	FACE PLATE ASSY	
21	SA1291001	1	メンイタパツキン	FACE PLATE PACKING	
22	104449001	2	ゴムセン15.5	RUBBER CAP, 15.5	
23	SA7271001	1	メンイタイトアンナイ	FACE PLATE THREAD GUIDE	
24	060350616	1	バインド35X6	SCREW BIND M3.5X6	
25	062501816	3	ナベコ5X18	SCREW, PAN M5X18	
26	SA7272101	1	ハリボウメタルDイトアンナイ	THREAD GUIDE, D	
			<-□□3用>	<For "-□□3">	
27	SA7273001	1	イトチヨウシボウダイクミ	THREAD TENSION BRACKET ASSY	
28	S02620201	1	イトトリバネ	THREAD TAKE-UP SPRING	
29	SA7275001	1	イトチヨウシバネ	TENSION SPRING	
			<-□□S用>	<For "-□□S">	
27	S55656301	1	イトチヨウシボウダイクミ	THREAD TENSION BRACKET ASSY	
28	100399201	1	イトトリバネ	THREAD TAKE-UP SPRING	
29	115188101	1	シユイトチヨウシバネ	TENSION SPRING	
			<-□□5用>	<For "-□□5">	
27	S55655201	1	イトチヨウシボウダイクミ	THREAD TENSION BRACKET ASSY	
28	S02620201	1	イトトリバネ	THREAD TAKE-UP SPRING	
29	S04632101	1	イトチヨウシバネ	TENSION SPRING	
30	S40938001	1	イトチヨウシボウタイ	THREAD TENSION BRACKET	
31	116922001	1	イトチヨウシボウ	TENSION STUD	
32	100402004	1	トメネジ3.57	SET SCREW, SM3.57	
33	145446001	2	イトチヨウシサラ	DISC, TENSION	
34	159805001	1	イトチヨウシサラオサエ	TENSION DISC PRESSER	
35	S12441001	1	チヨウシバネウエザガネ	WASHER	
36	S31032001	1	イトチヨウシナット	TENSION NUT	
37	114294001	1	Oリング	O-RING	

K . 糸巻関係 / Bobbin winder mechanism

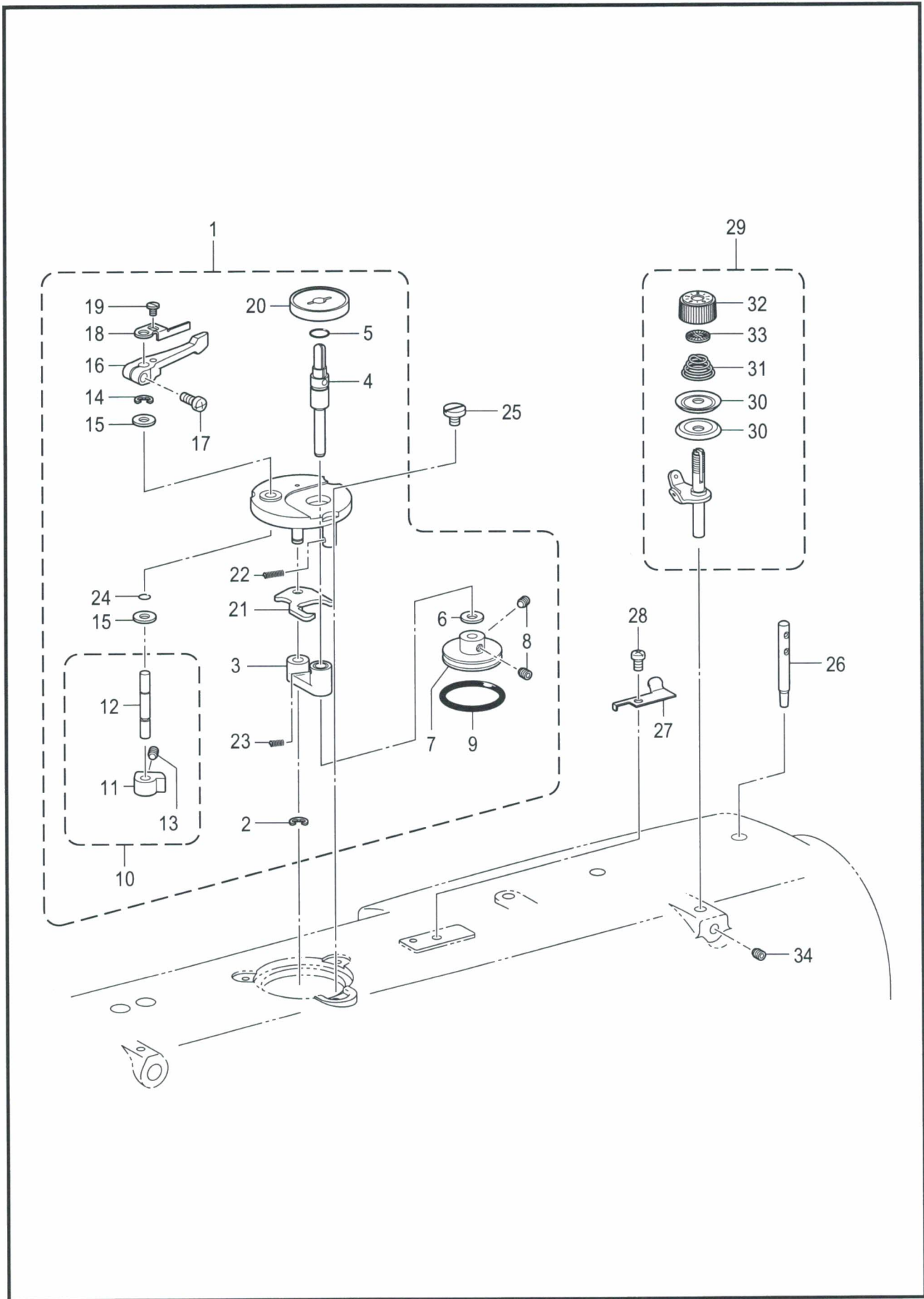

K. 糸巻関係 / Bobbin winder mechanism

REF.NO	CODE	Q'TY	品名	NAME OF PARTS	RM
1	SA1971101	1	イトマキユニット	BOBBIN WINDER UNIT	
2	048040342	1	トメワE4	RETAINING RING E4	
3	SA1975001	1	イトマキジクウケクミ	B-WINDER SHAFT SUPPORT ASSY	
4	SA1978001	1	イトマキジク	BOBBIN WINDER SHAFT	
5	081009070	1	OリングP9	O RING P9	
6	025060136	1	ヒラザガネシヨウ6	WASHER PLAIN S 6	
7	SA1980001	1	イトマキクルマ	BOBBIN WINDER WHEEL	
8	012500536	2	アナヒラ5X5	SET SCREW SOCKET (FT) M5X5	
9	S25789000	1	ゴムワ29	RUBBER RING, 29	
10	SA1981101	1	ボビンオサエカムクミ	BOBBIN PRESSER CAM ASSY	
11	SA1982101	1	ボビンオサエカム	BOBBIN PRESSER CAM	
12	SA1983001	1	イトマキウデジク	BOBBIN WINDER ARM SHAFT	
13	012500536	1	アナヒラ5X5	SET SCREW SOCKET (FT) M5X5	
14	048040342	1	トメワE4	RETAINING RING E4	
15	025060136	2	ヒラザガネシヨウ6	WASHER PLAIN S 6	
16	SA1984001	1	ボビンオサエウデ	BOBBIN PRESSER ARM	
17	062401216	1	ナベコ4X12	SCREW PAN M4X12	
18	SA1985001	1	ボビンオサエ	BOBBIN PRESSER	
19	S23418002	1	シメネジ4X5	SCREW M4X5	
20	SA1988001	1	ボビンウケ	BOBBIN SUPPORT	
21	SA1989001	1	イトマキレバー	BOBBIN WINDER LEVER	
22	SA1990101	1	モドシバネ	SPRING	
23	SA1991001	1	イトマキダイバネ	BOBBIN WINDER BASE SPRING	
24	SA2190001	1	OリングSS5	O RING, SS5	
25	SA1992101	3	イトマキコテイネジ	BOBBIN WINDER FIXED SCREW	
26	SA1359001	1	イトタテボウ	SPOOL PIN	
27	SA1360101	1	メス	KNIFE	
28	062500616	1	ナベコ5X6	SCREW PAN M5X6	
29	SA1994101	1	イトマキチヨウシクミ	BOBBIN WINDER TENSION ASSY	
30	145446002	2	イトチヨウシサラ	DISC, TENSION	
31	100401022	1	イトチヨウシバネ	TENSION SPRING	
32	S31032001	1	イトチヨウシナツト	TENSION NUT	
33	S12441001	1	チヨウシバネウエザガネ	WASHER	
34	012500536	1	アナヒラ5X5	SET SCREW SOCKET (FT) M5X5	

L . 糸切り関係 / Thread trimmer mechanism

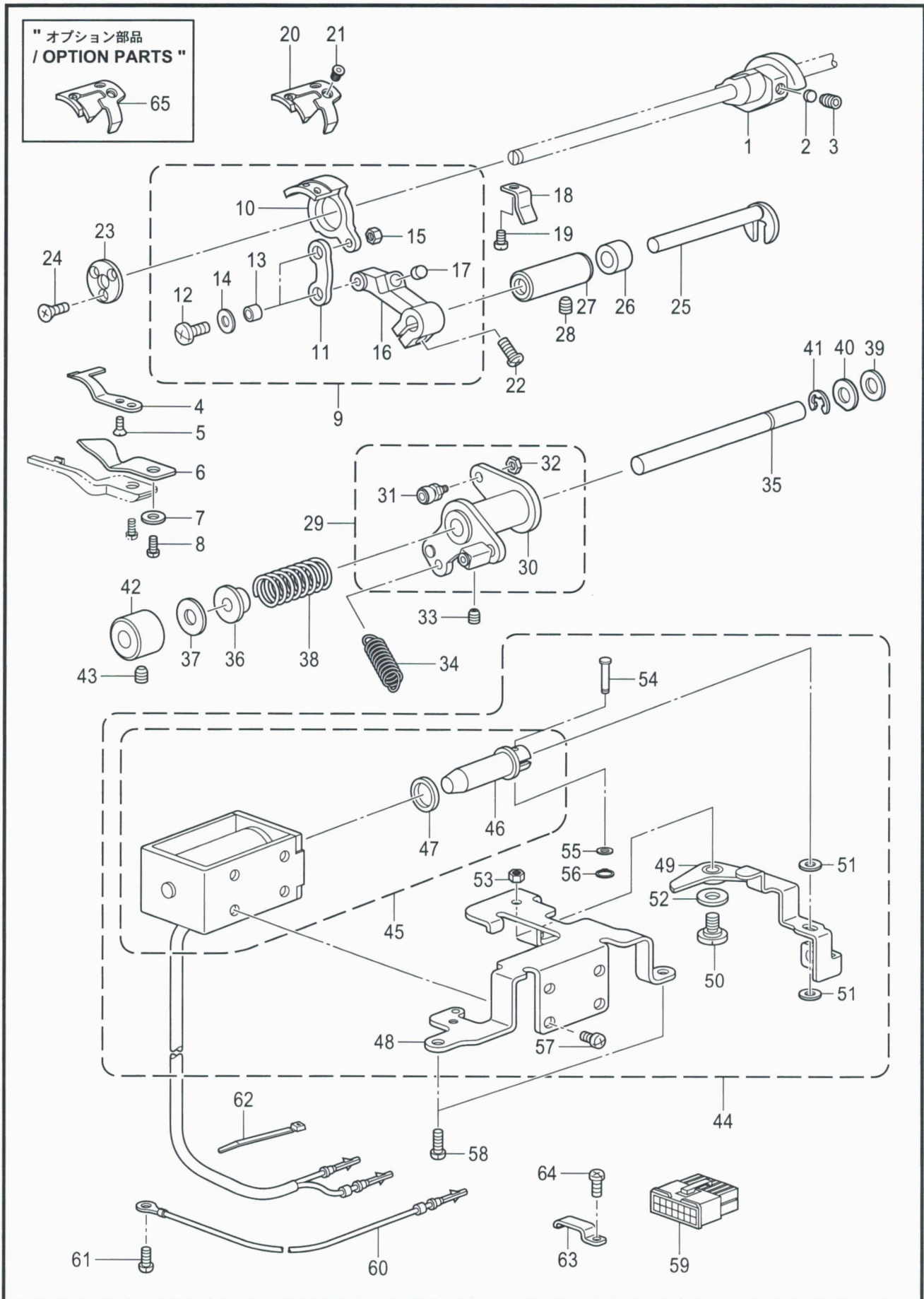

L. 糸切り関係 / Thread trimmer mechanism

REF.NO	CODE	Q'TY	品名	NAME OF PARTS	RM
1	SA7552001	1	イトキリカム	THREAD TRIMMER CAM	
2	154567000	2	カンザ5.3	SPACER, 5.3	
3	014771032	2	アナクボミ635-40X10	SET SCREW SOCKET SM6.35-40X10	
4	S02637001	1	コテイハ	FIXED KNIFE	
5	102843004	1	サラネジ3.57	SCREW, FLAT SM3.57	
6	S02643001	1	イトサバキ	LOWER THREAD FINGER	
7	026040236	1	ヒラザガネミガキ4	WASHER PLAIN M 4	
8	062400616	1	ナベコ4X6	SCREW PAN M4X6	
9	SA7282101	1	イトキリホルダクミ	THREAD TRIMMER HOLDER ASSY	
10	SA7283001	1	イトキリホルダ	HOLDER, M-KNIFE	
11	S25426101	1	イトキリレンカン	THREAD TRIMMER CONNECTING ROD	
12	SA7577001	2	バインドM4X10シール	SCREW BIND M4X10 SEAL	
13	SA5329001	2	カラー	COLLAR	
14	100645003	2	ザガネ	WASHER	
15	021400306	1	3シュナット4	NUT 3 M4	
16	SA7284101	1	イトキリレバー	THREAD TRIMMER LEVER	
17	SA7285001	1	レバーストツパ	LEVER STOPPER	
18	SA7341101	1	イトキリストツパイタ	THREAD TRIMMER STOPPER BASE	
19	062400616	1	ナベコ4X6	SCREW PAN M4X6	
20	S02645001	1	イドウハ	MOVABLE KNIFE	
21	148537101	2	サラネジ4.37	SCREW, FLAT (W/SOCKET) SM4.37	
22	062501416	1	ナベコ5X14	SCREW PAN M5X14	
23	SA7287001	1	イトキリホルダオサエイタ	KNIFE HOLDER PRESSER PLATE	
24	004301016	3	+サラコ3X10	SCREW FLAT M3X10	
25	S02647021	1	フタマタジク	FORKED SHAFT	
26	S02648001	1	カラー	COLLAR	
27	154581001	1	フタマタジクメタル	FORKED SHAFT BUSH	
28	012060536	1	アナヒラ6X5	SET SCREW, SOCKET (FT) M6X5	
29	SA1362101	1	イトキリカムレバーソウクミ	THREAD TRIMMER LEVER UNIT	
30	SA1363001	1	イトキリカムレバークミ	THREAD TRIMMER LEVER ASSY	
31	SA2258001	1	コロジクCクミ	ROLLER SHAFT, C ASSY	
32	105234003	1	ナット4.37	NUT SM4.37	
33	S23651001	1	アナヒラ6X6ホソメ	SET SCREW SOCKET (FT) M6X6	
34	SA2383001	1	カムレバーバネ	CAM LEVER SPRING	
35	154593201	1	イトキリカムレバークミ	THREAD TRIMMER CAM LEVER SHAFT	
36	154594000	1	カラー	COLLAR	
37	S25434000	1	クツシヨンゴム	RUBBER CUSHION	
38	154595001	1	カムレバーモッドシバネ	SPRING, EXTENSION	
39	154596000	1	イトキリカムレバークツシヨン	CUSHION	
40	110367001	1	ザガネ	WASHER, PLAIN SPECIAL 8	
41	048060342	1	トメワE6	RETAINING RING E6	
42	SA1366001	1	カムレバークミメタル	CAM LEVER SHAFT BUSH	
43	012060536	1	アナヒラ6X5	SET SCREW, SOCKET (FT) M6X5	
44	SA1391601	1	イトキリソレノイドクミ	THREAD TRIMMER SOLENOID ASSY	
45	SA1392001	1	イトキリソレノイド	THREAD TRIMMER SOLENOID	
46	SA1393001	1	ソレノイドプランジャー	SOLENOID PLUNGER	
47	S36893050	1	ゴムクツシヨン	RUBBER CUSHION	
48	SA1367201	1	イトキリソレノイドダイ	THREAD TRIMMER SOLENOID BASE	
49	SA7898201	1	ソレノイドレバー	SOLENOID LEVER	
50	SA7899001	1	ダンネジ6	SHOULDER SCREW M6	
51	SA2097101	2	シヨウオンシート	SILENT SHEET	
52	SA7900001	1	ヒラザガネ	WASHER PLAIN	
53	021060306	1	3シュナット6	NUT 3 M6	
54	SA7288001	1	レンケツピン	PIN	
55	025040232	1	ヒラザガネチュウ4	WASHER PLAIN M 4	
56	048040142	1	トメワジクヨウC4	RETAINING RING EXTERNAL C4	
57	062400816	4	ナベコ4X8	SCREW PAN M4X8	
58	062501216	3	ナベコ5X12	SCREW PAN M5X12	
59	S38687000	1	コネクタ5557-14R	CONNECTOR, 5557-14R	
60	SA1998001	1	アースセンクミ	GROUND WIRE ASSY	
61	062500816	1	ナベコ5X8	SCREW PAN M5X8	
62	SA2868001	3	バインド	BAND	

L. 糸切り関係 / Thread trimmer mechanism

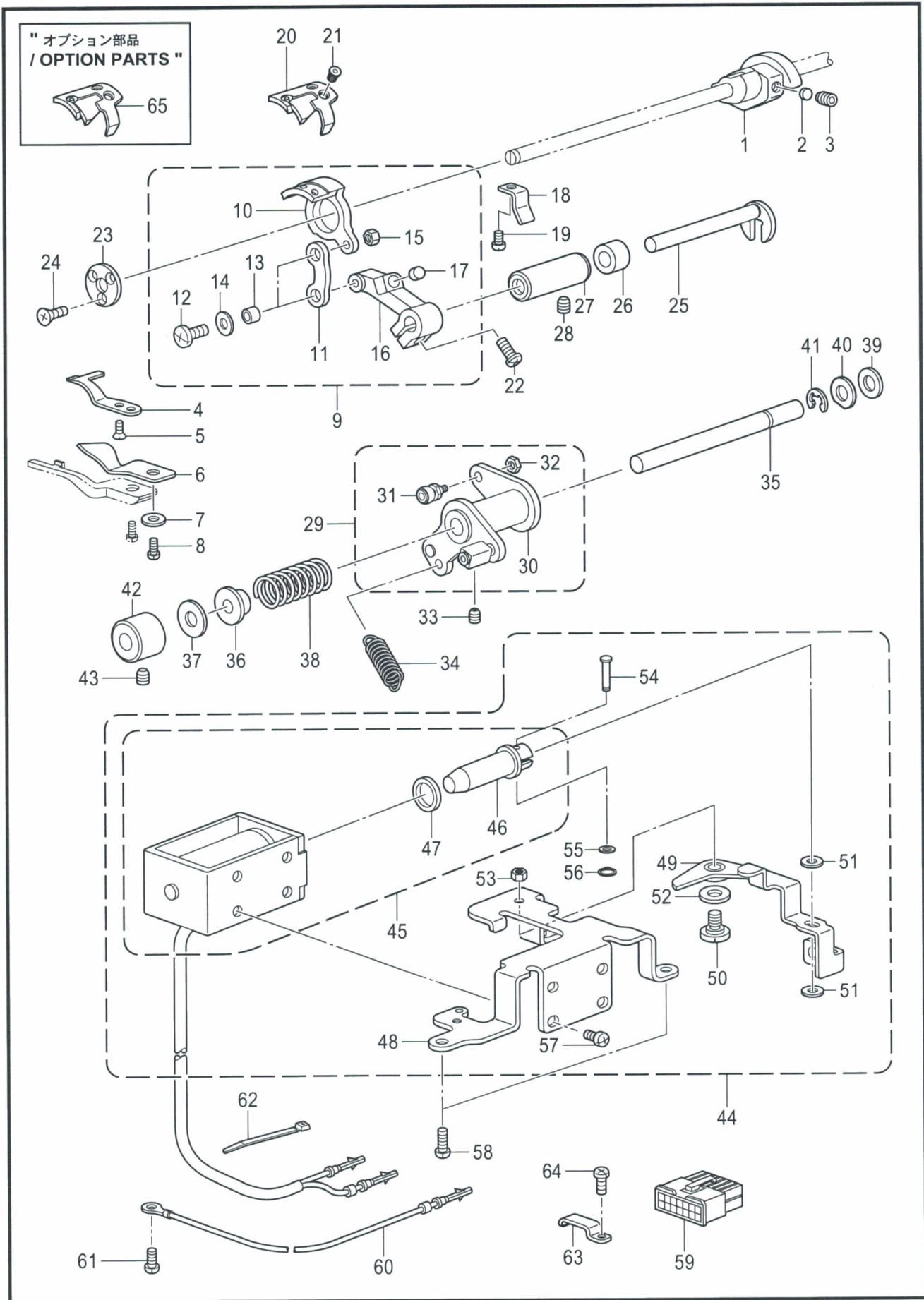

L. 糸切り関係 / Thread trimmer mechanism

REF.NO	CODE	Q'TY	品名	NAME OF PARTS	RM
63	SA1394101	1	コードオサエU3	CORD HOLDER U3	
64	062500816	1	ナベコ5X8	SCREW PAN M5X8	
			<オプション用>	<OPTION PARTS>	
65	S02646001	1	イドウハS	MOVABLE KNIFE, S	

M . 糸緩め関係 / Tension release mechanism

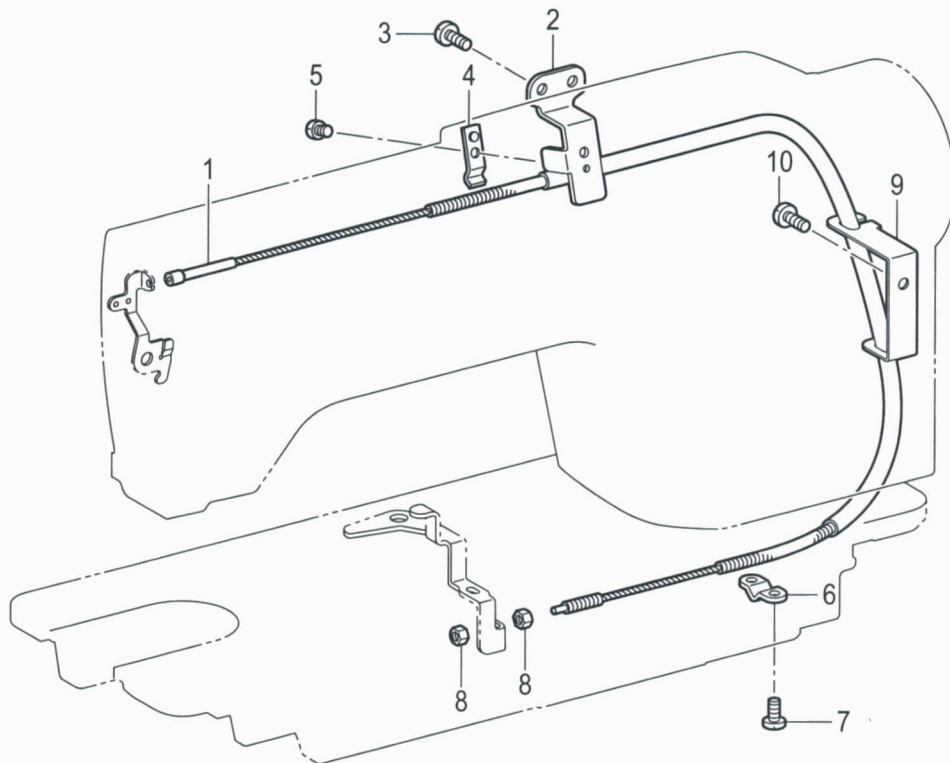

M. 系緩め関係 / Tension release mechanism

REF.NO	CODE	Q'TY	品名	NAME OF PARTS	RM
1	SA1371201	1	イトユルメワイヤー	TENSION RELEASE WIRE	
2	SA1372001	1	ワイヤーホルダU	WIRE HOLDER, U	
3	062500816	2	ナベコ5X8	SCREW PAN M5X8	
4	SA1373001	1	ワイヤーオサエU	WIRE HOLDER, U	
5	060400516	1	バインド4X5	SCREW BIND M4X5	
6	154607101	1	イトユルメワイヤーオサエD	WIRE HOLDER, D	
7	060400816	2	バインド4X8	SCREW BIND M4X8	
8	110161004	2	ナツト4.76	NUT, SM4.76	
9	SA2171001	1	ワイヤーコードホルダ	WIRE CORD HOLDER	
10	062500816	1	ナベコ5X8	SCREW PAN M5X8	

N. 糸払い関係 / Thread wiper mechanism

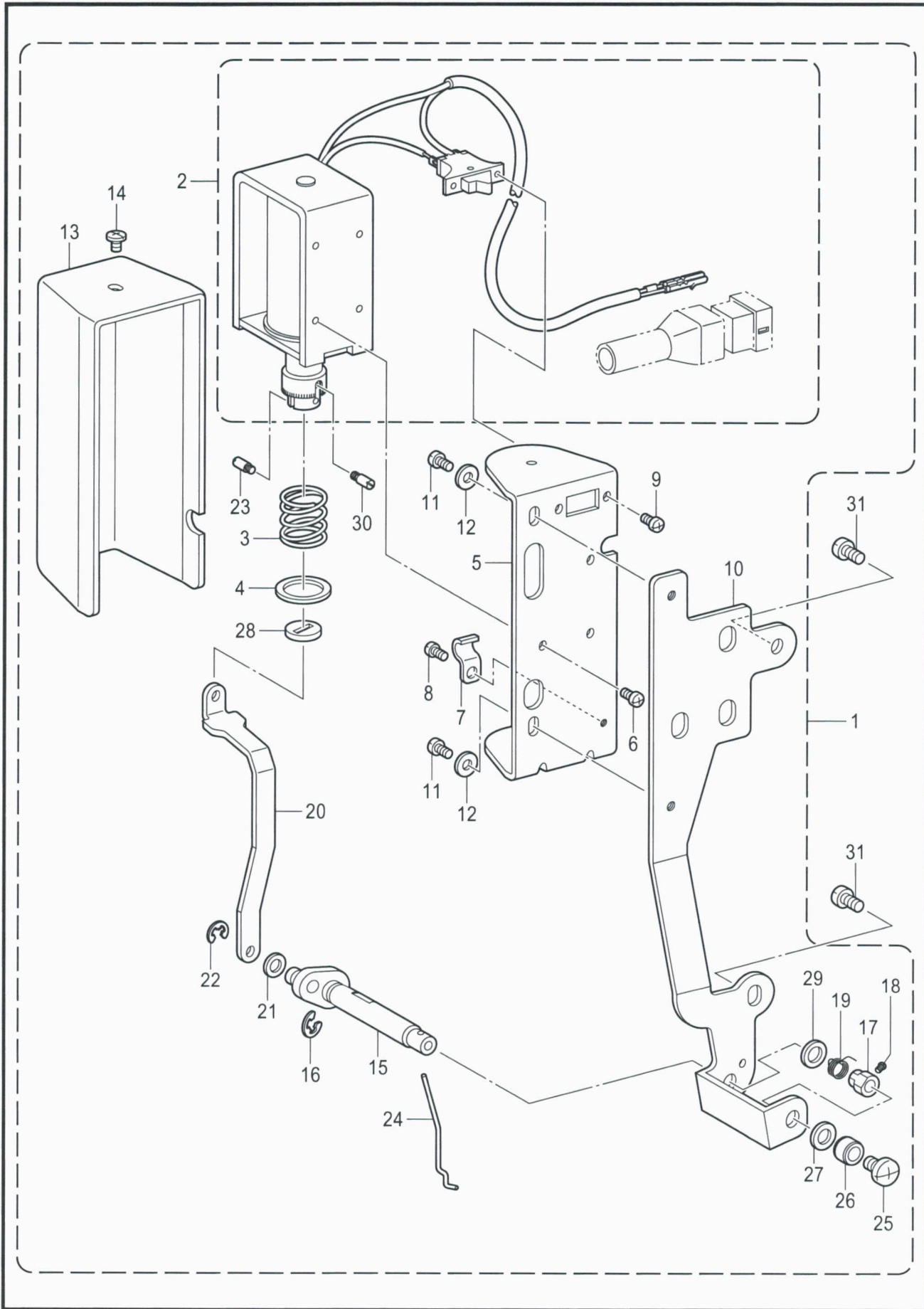

S-7200B-405

N. 糸払い関係 / Thread wiper mechanism

REF.NO	CODE	Q'TY	品名	NAME OF PARTS	RM
1	SA1374301	1	イトハライソウチクミ	THREAD WIPER DEVICE ASSY	
2	SA1396001	1	イトハライソレノイドクミ	THREAD WIPER SOLENOID ASSY	
3	S41206001	1	イトハライバネ	THREAD WIPER SPRING	
4	S41205001	1	ヒラザガネ	WASHER, PLAIN	
5	S25449201	1	ソレノイドリツケイタ	SOLENOID SETTING PLATE	
6	062300616	3	ナベコ3X6	SCREW PAN M3X6	
7	140647101	1	コードオサエ	CORD HOLDER	
8	062300616	1	ナベコ3X6	SCREW PAN M3X6	
9	062300616	2	ナベコ3X6	SCREW PAN M3X6	
10	SA1376001	1	イトハライドダイ	THREAD WIPER BASE	
11	062400616	2	ナベコ4X6	SCREW PAN M4X6	
12	026040236	2	ヒラザガネミガキ4	WASHER PLAIN M 4	
13	SA8002001	1	ソレノイドカバー	SOLENOID COVER	
14	060400516	1	バインド4X5	SCREW BIND M4X5	
15	SA1967001	1	イトハライクランククミ	THREAD WIPER CRANK ASSY	
16	048040342	1	トメワE4	RETAINING RING E4	
17	S25454001	1	セットカラー	SET SCREW COLLAR	
18	S25279101	1	アタマトメクボミM35-5	SET SCREW (CP) M3.5-5	
19	SA2287001	1	ワイパーバネ	SPRING	
20	SA1377001	1	イトハライロツド	THREAD WIPER ROD	
21	110735002	1	ザガネ	WASHER	
22	048030342	1	トメワE3	RETAINING RING E3	
23	S25456001	1	プランジヤピン	PLUNGER PIN	
24	SA1378201	1	イトハライ	THREAD WIPER	
25	060400516	1	バインド4X5	SCREW BIND M4X5	
26	146288001	1	イトハライジクカラー	THREAD WIPER STUD COLLAR	
27	S03677001	1	ザガネ	WASHER	
28	S41207000	1	スペーサゴム	SPACER RUBBER	
29	149097000	1	シヨウオンシート	SILENT SHEET	
30	S25456001	2	プランジヤピン	PLUNGER PIN	
31	062500816	2	ナベコ5X8	SCREW PAN M5X8	

P1. コントロールボックス、モータ関係 / Control box and motor mechanism

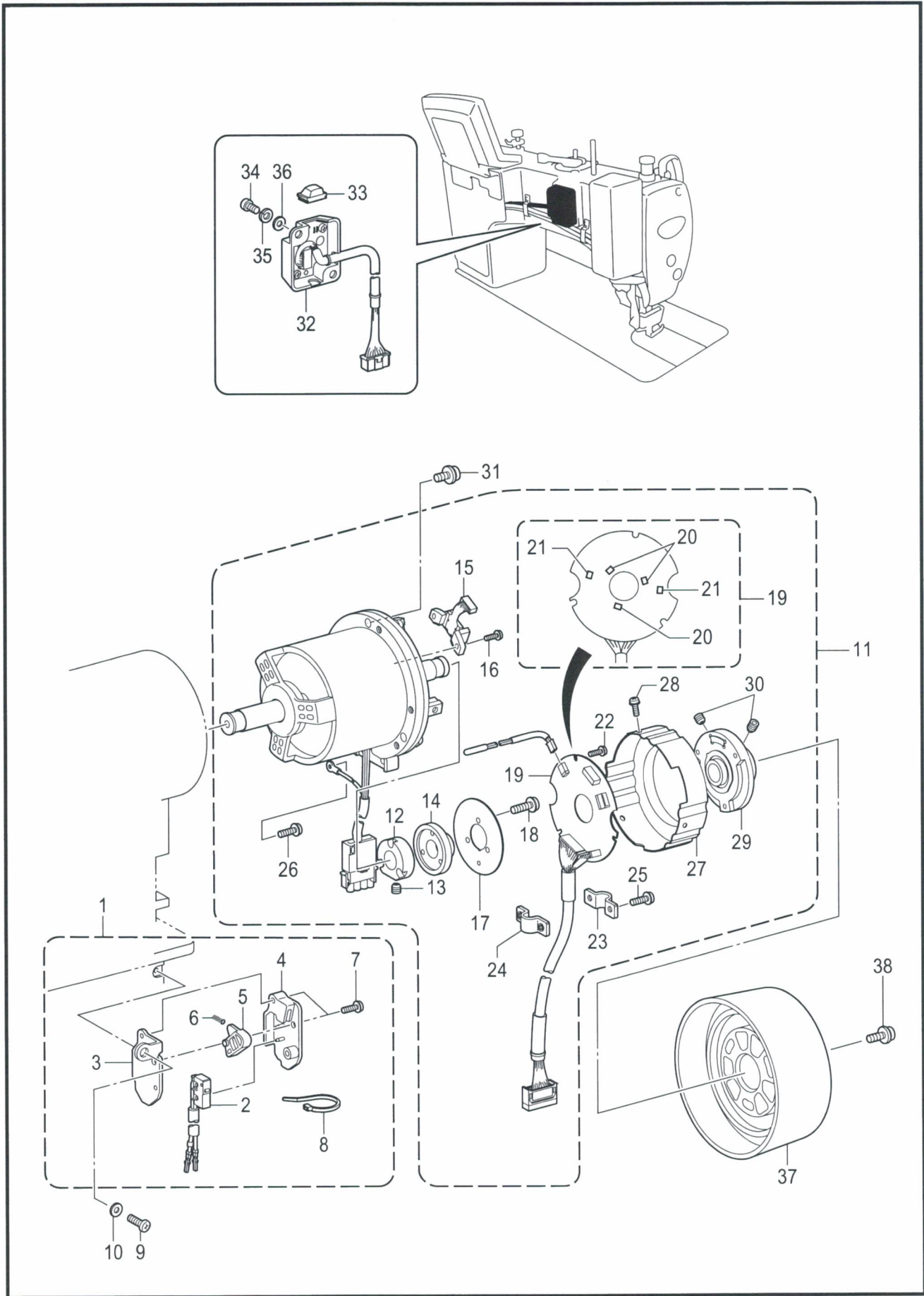

S-7200B-502

P1. コントロールボックス、モータ関係 / Control box and motor mechanism

REF.NO	CODE	Q'TY	品名	NAME OF PARTS	RM
1	SA7291101	1	セーフティスイッチクミ	SAFETY SWITCH ASSY	
2	SA7325001	1	マイクロスイッチクミ	MICRO SWITCH ASSY	
3	SA7292101	1	セーフティスイッチイタ	SAFETY SWITCH BASE	
4	SA5730101	1	セーフティスイッチベース	SAFETY SWITCH BASE	
5	SA5732001	1	セーフティスイッチレバー	SAFETY SWITCH LEVER	
6	SA5731001	1	セーフティスイッチバネ	SAFETY SWITCH SPRING	
7	SA7293001	2	ナベザクミM3X12	SCREW, PAN (S/P W) M3X12	
8	SA2868001	1	バンド	BAND	
9	062060816	1	ナベコ6X8	SCREW PAN M6X8	
10	025060136	1	ヒラザガネシヨウ6	WASHER PLAIN S 6	
11	J03940001	1	モータクミCDD-HS	MOTOR ASSY CDD-HS	
12	J03955001	1	ドラムコティCDD	DRUM CDD	
13	014400632	2	アナクボミ4X6	SET SCREW SOCKET (CP) M4X6	
14	J03956001	1	ジシヤク180P36	MAGNET 180P36	
15	J03957001	1	MRセンサクミ180P	MR SENSOR ASSY 180P	
16	0A4300806	2	+ナベザクミ3X8DA	SCREW PAN (S/P WASHER) M3X8	
17	J03958001	1	シヤヘイイタCDD	SHIELD PLATE CDD	
18	0A4261006	3	+ナベザクミ26X10DA	SCREW PAN (S/P WASHER) M2.6X10	
19	J04487001	1	CDD-ENCキバンクミ#2	PCB ASSY CDD-ENC#2	
20	J03983001	3	ホ-ルICEW-400	HALL ELEMENT: ICEW-400	
21	J03984001	2	ホ-ルICEW-450	HALL ELEMENT: ICEW-450	
22	0A5300606	3	+ナベザクミ3X6DB	SCREW PAN (S/P WASHER) M3X6	
23	J03961001	1	コードオサエ(アナ)	CORD HOLDER (HOLE)	
24	J03962001	1	コードオサエ(ネジ)	CORD HOLDER (TAPPING)	
25	0A4401606	2	+ナベザクミ4X16DA	SCREW PAN (S/P WASHER) M4X16	
26	0A4401006	1	+ナベザクミ4X10DA	SCREW PAN (S/P WASHER) M4X10	
27	J04296001	1	エンコーダカバー-CDD#2	ENCODER COVER CDD#2	
28	0A4300806	3	+ナベザクミ3X8DA	SCREW PAN (S/P WASHER) M3X8	
29	J03964001	1	プ-リトリツケダイクミCDD	PULLEY HOLDER ASSY CDD	
30	014500632	2	アナクボミ5X6	SET SCREW SOCKET (CP) M5X6	
31	SA2354001	3	+ナベセットネジ5X18	SCREW PAN M5X18	
32	J04442001	1	トウブケンシュツユニット#2	HEAD DETECTOR UNIT #2	
33	J04392001	1	LEDカバー	LED COVER	
34	062501216	2	ナベコ5X12	SCREW PAN M5X12	
35	028050246	2	バネザガネ2-5	WASHER SPRING 2-5	
36	026050136	2	ヒラザガネコガタ5	WASHER PLAIN S 5	
37	SA4211001	1	プ-リCDD	PULLEY,CDD	
38	SA3025001	3	ナベザクミ4X10DA	SCREW PAN(S/P WASHER)M4X10	

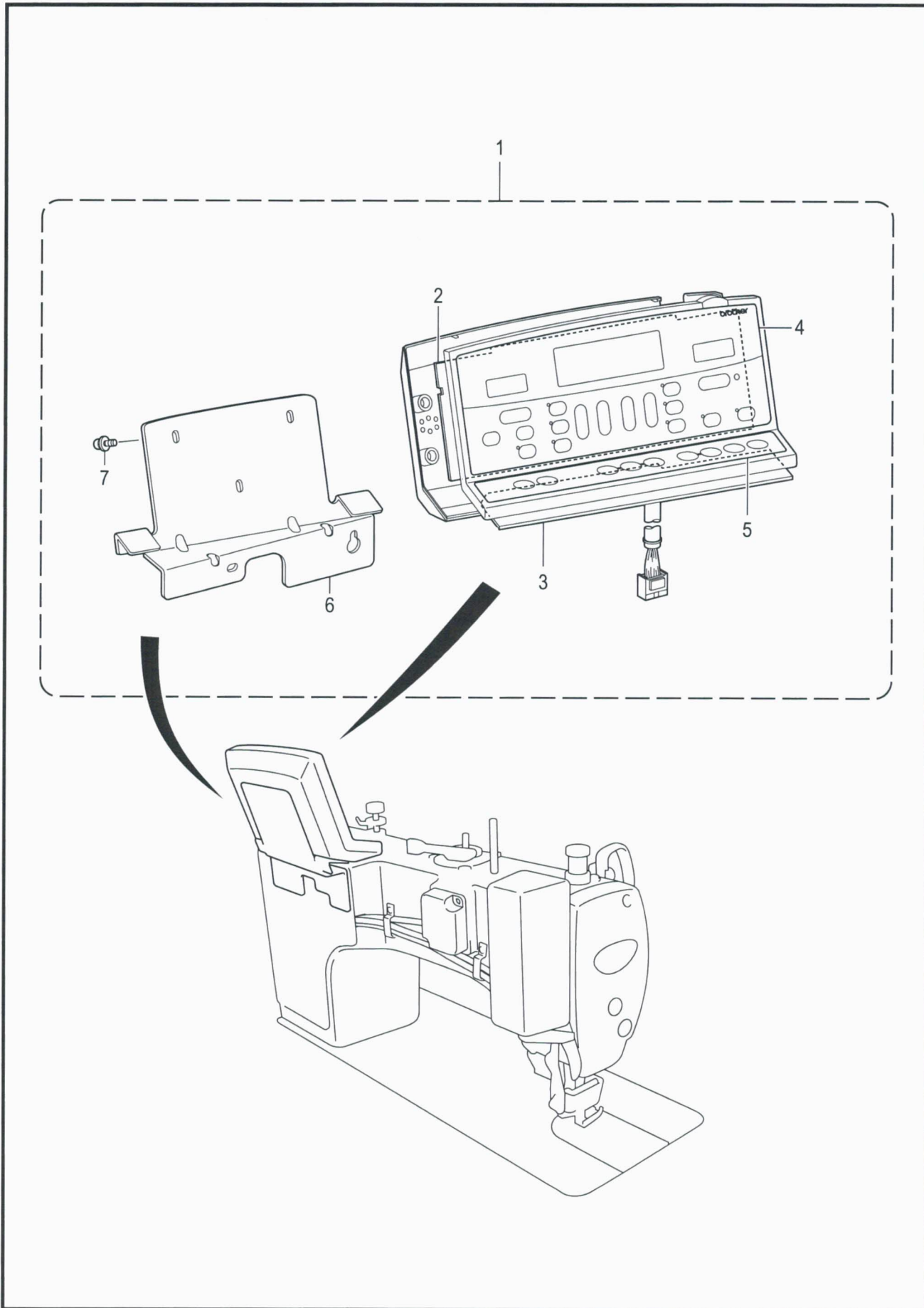

P2 . コントロールボックス関係 / Control box mechanism

REF.NO	CODE	QTY	品名	NAME OF PARTS	RM
1	BMP2060-0000000-CG40		< 中国向 > G40パネル	< For China Only > G-40-PANEL-CHINA	
1	BMP2060-0000000-0G40		< 中国・欧州以外向 > G40パネル	< Except for China and Europe > G-40-PANEL	
1	BMP2060-0000000-EG40		< 欧州向 > G40パネル	< For Europe Only > G-40-PANEL-EU	
2	J80973001	1	G40パネル基板	G40 PANEL PCB ASSY	
3	J80974001	1	G40サブ基板	G40 SUB PCB ASSY	
4	J03975001	1	G40パネルカザリイタ1	G40 PANEL SHEET 1	
5	J03976001	1	G40パネルカザリイタ2	G40 PANEL SHEET 2	
6	J04195001	1	パネルトリツケイタ#2	PANEL SETTING PLATE#2	
7	J04273001	3	ナベザクミ4X10DB	SCREW, PAN (S/P WASHER) M4X10	

P3 . コントロールボックス関係 / Control box mechanism

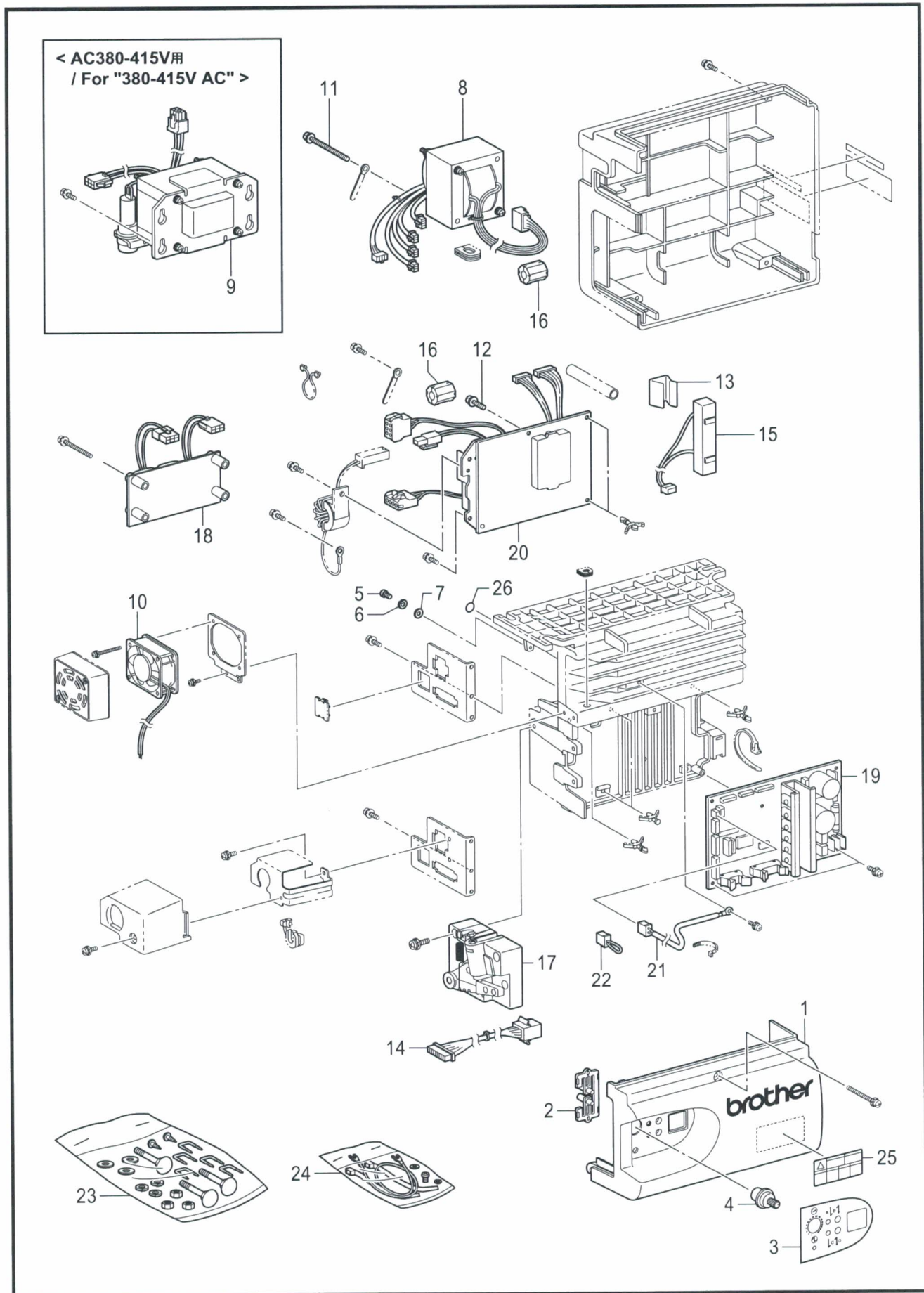

S-7200B-502

P3 . コントロールボックス関係 / Control box mechanism

REF.NO	CODE	Q'TY	品名	NAME OF PARTS	RM
1	J04393001	1	CDDマエフタGO	FRONT BOX COVER CDD GO	
2	J04438001	1	キートツブCDD-GO	KEY TOP	
3	J04440001	1	PカザリイタGO	PANEL SHEET CDD GO	
4	J03733001	1	VツマミLCA	SPEED ADJUST KNOB	
5	062400863	1	ナベコ4X8	SCREW, PAN M4X8	
6	028040245	1	バネザガネ2-4	WASHER, SPRING 2-4	
7	025040173	1	ヒラザガネシヨウ4	WASHER, PLAIN S 4	
8	J04097001	1	<AC100 - 110V用> トランスCDD-100V-SP	<For " 100 - 110V AC" > TRANSFORMER, CDD-100V-SP	
8	J04098001	1	<AC200 - 230V用> トランスCDD-200V-SP	<For " 200 - 230V AC" > TRANSFORMER, CDD-200V-SP	
9	J04593001	1	<AC380 - 415V用> トランス400V-SP	<For " 380 - 415V AC" > TRANSFORMER, 400V-SP	
10	J04167001	1	DCファンCDDクミ#2	DC FAN ASSY, CDD #2	
11	J01411001	2	<AC100-200Vトランス用> +ナベザクミ4X50DA	<For Transformer of " 100 - 200V AC" > SCREW, PAN (S/P WASHER) M4X50	
12	J00494001	2	+ナベセット4X14DA	SCREW, PAN (S/P WASHER) M4X14	
13	J03739001	1	CRコテイイタ	SPRING PLATE, CR	
14	J04099101	1	フットプラグクミCDD	FOOT PLUG ASSY, CDD	
15	J04100001	1	セメントR40/220クミ#6	CEMENT RESISTOR ASSY, 40/220#6	
16	J04468001	2	<欧州向用> コアESD-SR-120	<For Europe> CORE:SD-SR-120	
17	J80967001	1	<前一段, 後一段タイプ> フミコムユニットCDD-コクホ	<Type forward 1 step, backward 1 step> TREADLE UNIT ASSY, CDD G	
17	J80968001	1	<前二段, 後二段タイプ> フミコムユニットCDD-ユホ	<Type forward 2 step, backward 2 step> TREADLE UNIT ASSY, CDD H	
18	J80970001	1	<欧州向用> CEフィルタキバンクミ	<For Europe> CE FILTER PCB ASSY	
19	J80964201	1	SキバンCDDクミ#GO	CONTROL PCB ASSY CDD#GO	
20	J80965001	1	<110V AC用> DキバンCDD1-110Vクミ	<For " 110V AC" > POWER PCB ASSY, CDD 1-110V	
20	J80966101	1	<220 - 240V AC用> DキバンCDD1-230Vクミ	<For " 220 - 240V AC" > POWER PCB ASSY CDD 1-230V	
21	J04169001	1	<400V AC用> CDDサーミスタ#2	<For " 400V AC" > THERMISTOR, CDD #2	
22	J04168001	1	<400V AC以外用> ショートコネクタ	<Except for " 400V AC" > SHORT CONNECTOR	
23	J04210001	1	カクネ8X65クミ	BOLT ASSY, SQUARE M8X65	
24	J04243001	1	アースコードネジタイクミ	EARTH CORD SCREW TIE ASSY	
25	J04115001	1	ラベル感電6ヶ国	LABEL, ELEC. SHOCK 6 LANG	
26	S37060001	1	アースマーク	LABEL, GROUNDING	

P4 . コントロールボックス関係 (オプション部品) / Control box mechanism (Option parts)

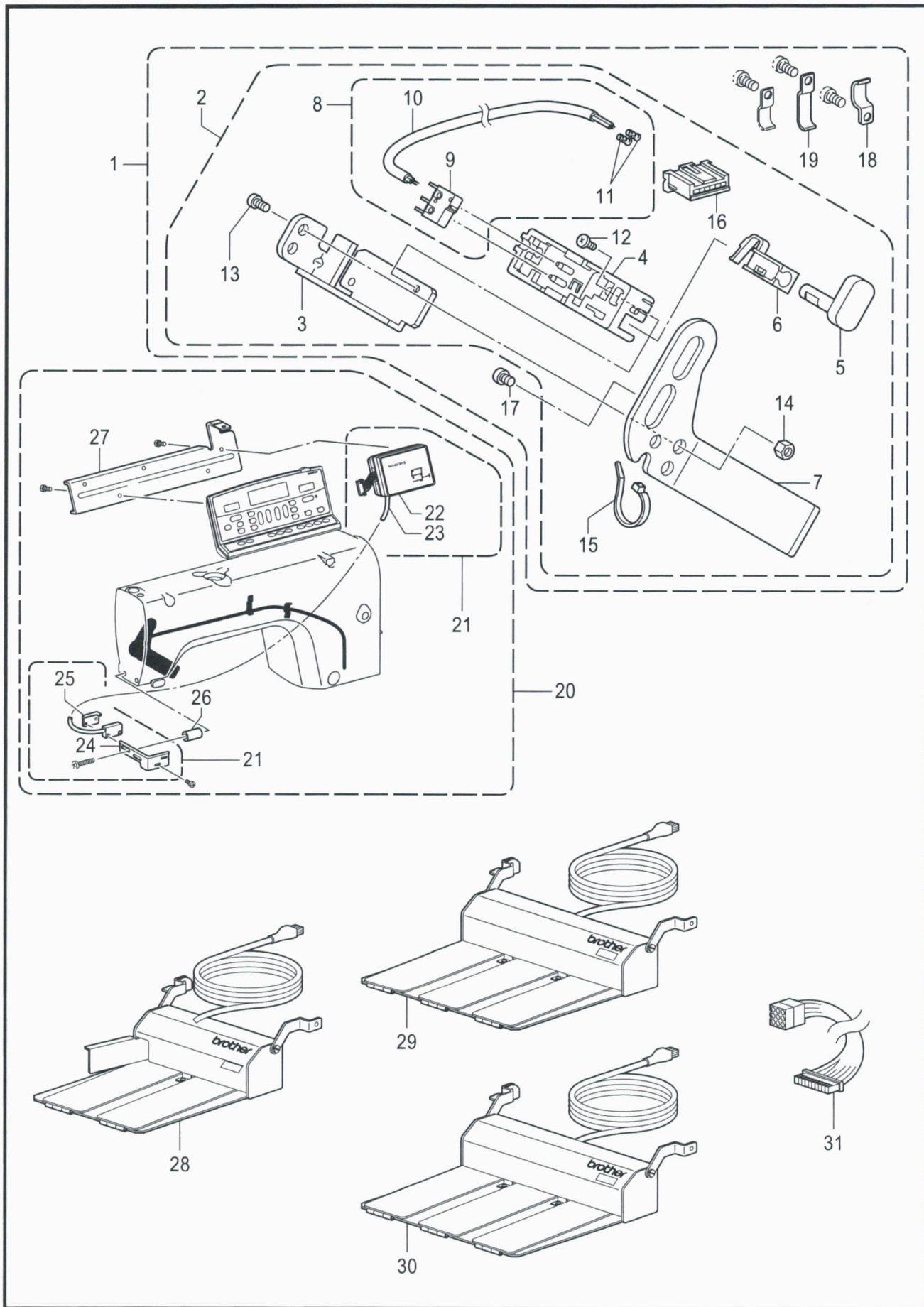

S-7200B-502

P4. コントロールボックス関係 (オプション部品) / Control box mechanism (Option parts)

REF.NO	CODE	Q'TY	品名	NAME OF PARTS	RM
1	SA2407001	1	オプションアクチュエータセット	OPTION ACTUATOR SET	
2	SA2388101	1	オプションアクチュエータクミ	OPTION ACTUATOR ASSY	
3	SA2270001	1	Rスイッチササエ	REVERSE SWITCH BRACKET	
4	S34281000	1	Rスイッチダイ	REVERSE SWITCH BRACKET	
5	SA4098001	1	アクチュエータ	ACTUATOR	
6	SA4099001	1	Rスイッチバネ	REVERSE SWITCH SPRING	
7	SA2389001	1	オプションスイッチトリツケイタ	OPTION SWITCH SETTING PLATE	
8	SA2386001	1	オプションスイッチクミ	OPTION SWITCH ASSY	
9	S32907050	1	マイクロスイッチ	MICRO SWITCH	
10	SA2387001	1	コード	CODE	
11	SA2405001	2	ソケットコンタクト	SOCKET CONNECTOR	
12	060300606	1	バインド3X6	SCREW BIND M3X6	
13	062400816	2	ナベコ4X8	SCREW PAN M4X8	
14	021400206	2	2シュナット4	NUT 2 M4	
15	S04159000	1	バインド1M	BAND, 1M	
16	SA2406001	1	コネクタXAP-06V-1	CONNECTOR,XAP-06V-1	
17	062500616	2	ナベコ5X6	SCREW, PAN M5X6	
18	SA1388101	1	コードオサエ	CORD HOLDER	
19	SA2390101	1	コードオサエU4	CORD HOLDER,U4	
20	J80975001	1	S2センサー#S7200	S2 SENSOR,#S7200	
21	J04179001	1	S2センサークミCDD	S2 SENSOR ASSY,CDD	
22	233268002	1	S2センサーカザリイタ	EMBLEM PLATE	
23	J04186001	1	センサーコードクミ#NOR	SENSOR HARNESS ASSY NOR	
24	J04215001	1	センサーコティイタ	SENSOR FIXNG PLATE	
25	J04189001	1	センサートリツケイタ	SENSOR SETTING PLATE	
26	J04249001	2	センサートリツケカラー	SENSOR SETTING COLLAR	
27	J04314001	1	S2センサートリツケイタクミ	S2 SENSOR SETTING PLATE,ASSY	
			<欧州向>	<For Europe only>	
28	J800810E0	1	DDタッチペダル40カヘン#6	PEDAL STAND OPE VARIABLE 40#6	
29	J803800E0	1	DDタッチペダル3Pカヘン40	PEDAL STAND OPE DD 3P VARI 40	
30	J806300E1	1	DDタッチペダル 2ソク ホ	STANDING OPERATION 3-PEDAL 2S	
31	J04099101	1	フットプラグクミCDD	FOOT PLUG ASSY CDD	
			<欧州向以外>	<Except for Europe>	
28	J80081040	1	DDタッチペダル40カヘン#6	PEDAL STAND OPE VARIABLE 40#6	
29	J80380040	1	DDタッチペダル3Pカヘン40	PEDAL STAND OPE DD 3P VARI 40	
30	J80630001	1	DDタッチペダル 2ソク ホ	STANDING OPERATION 3-PEDAL 2S	
31	J04099101	1	フットプラグクミCDD	FOOT PLUG ASSY CDD	

Q. 膝スイッチ関係 / Knee switch mechanism

" オプション部品 / OPTION PARTS "

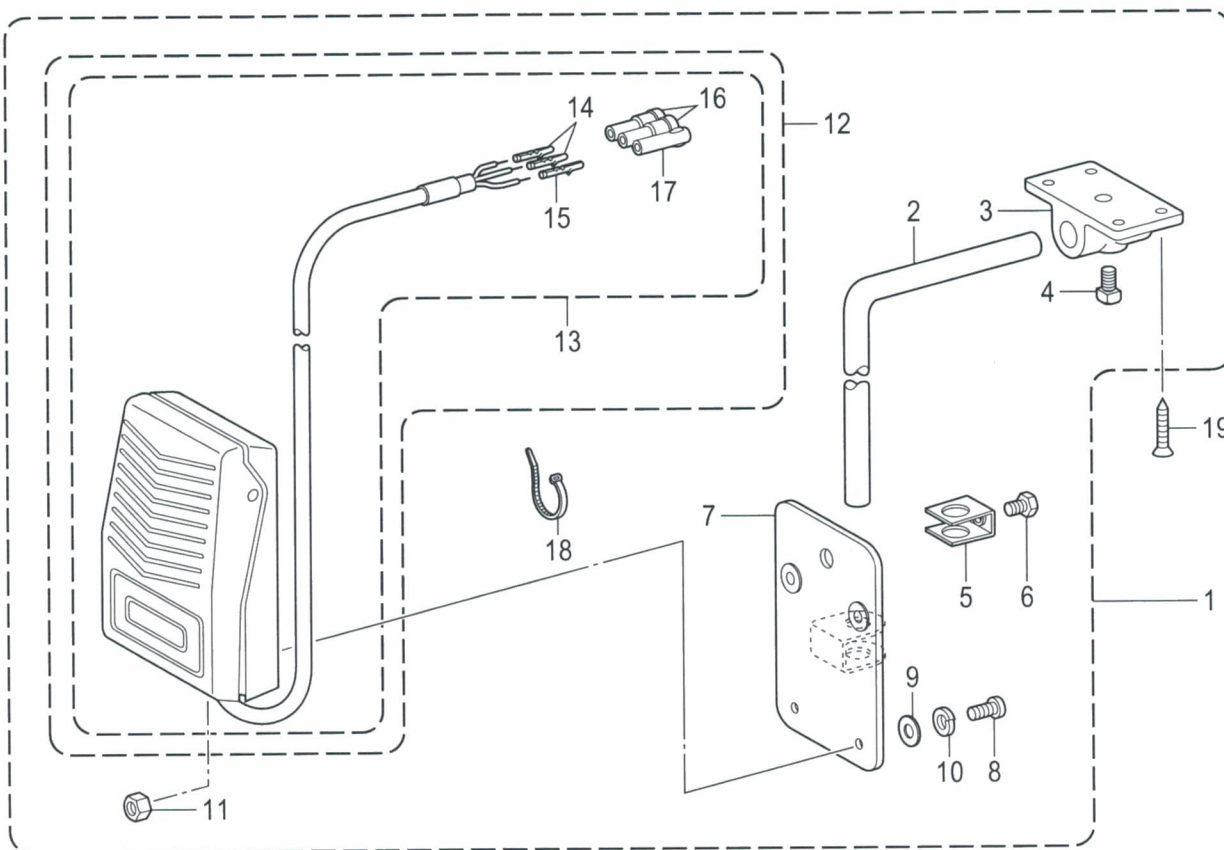

Q. 膝スイッチ関係 / Knee switch mechanism

REF.NO	CODE	Q'TY	品名	NAME OF PARTS	RM
			<オプション用>	<OPTION PARTS>	
1	S25457101	1	ヒザスイッチクミ	KNEE SWITCH ASSY	
2	142026003	1	ヒザスイッチタテジク	KNEE SWITCH SHAFT	
3	142027001	1	ヒザスイッチタテジクウケ	BRACKET	
4	100463001	1	4カクボルト7.94	BOLT, SQUARE SM7.94	
5	114967001	1	ヒザアテストツパ	KNEE LIFTER PLATE STOPPER	
6	110087001	1	ボルト5.95	BOLT, SM5.95-28X8	
7	S07027001	1	ヒザスイッチトリツケイタ	K-LIFTER SWITCH SETTING PLATE	
8	062401006	4	ナベコ4X10	SCREW PAN M4X10	
9	025040233	4	ヒラザガネチユウ4	WASHER, PLAIN M 4	
10	028040243	4	バネザガネ2-4	WASHER, SPRING 2-4	
11	021400164	4	1シユナツト4	NUT, 1 M4	
12	S31938001	1	スイッチコードクミ	SWITCH CORD ASSY	
13	S31939001	1	フットスイッチクミ	FOOT SWITCH ASSY	
14	143549000	2	ピンタ-ミナルオス	TERMINAL PIN, MALE	
15	143548000	1	ピンタ-ミナルメス	TERMINAL PIN, FEMALE	
16	146046000	2	ナイロンコネクタ	NYLON CONNECTOR	
17	146194000	1	ナイロンコネクタ-	NYLON CONNECTOR	
18	149799000	1	タイラツブS	BEAD BAND, S	
19	034422503	4	+2サラモク41X25	WOOD SCREW, FLAT 2 M4.1X25	

R. 逆転スイッチ関係 / Quick reverse switch mechanism

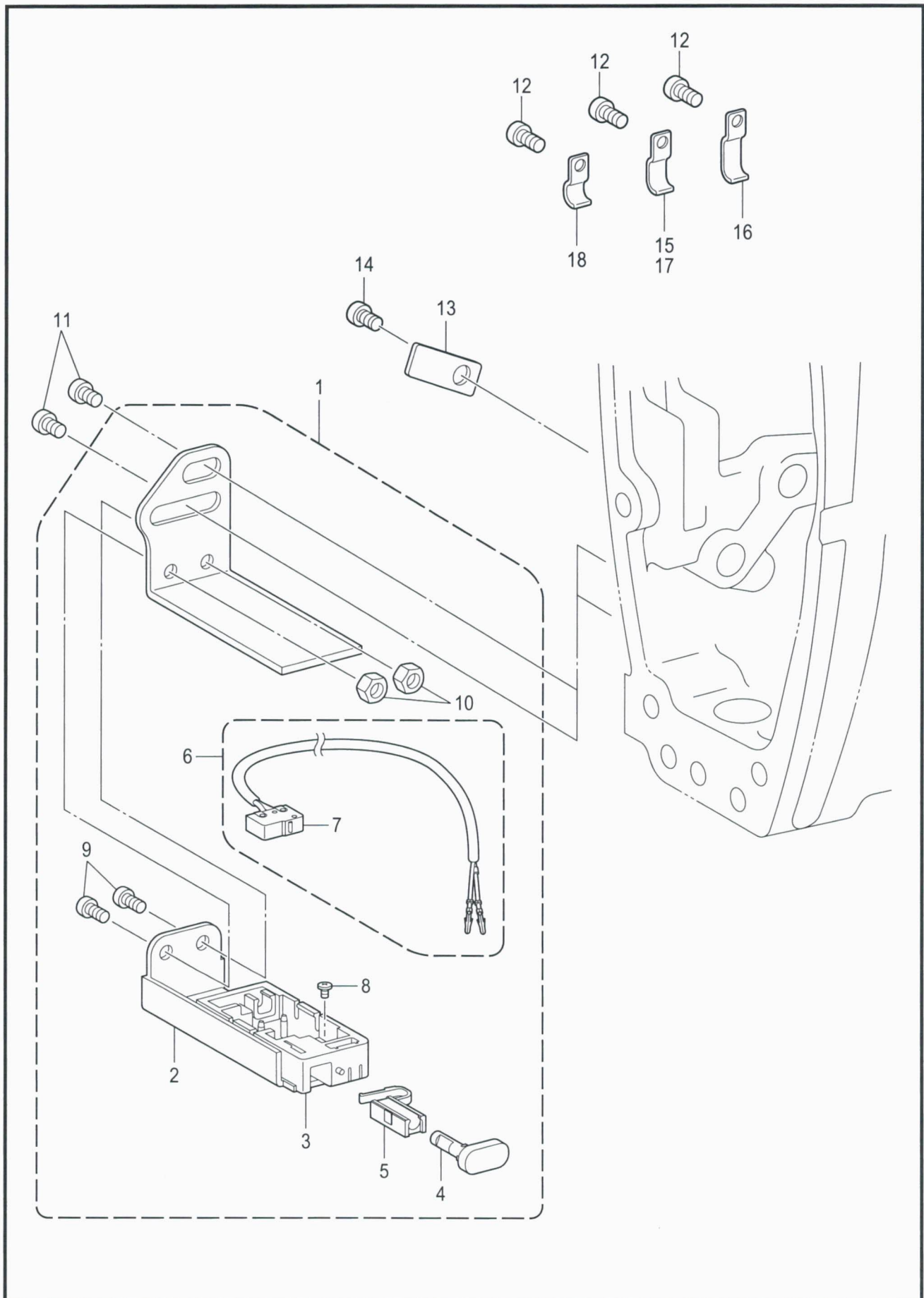

R. 逆転スイッチ関係 / Quick reverse switch mechanism

REF.NO	CODE	Q'TY	品名	NAME OF PARTS	RM
1	SA7294001	1	Rアクチュエータクミ	R-ACTUATOR ASSY	
2	SA2270001	1	Rスイッチササエ	REVERSE SWITCH BRACKET	
3	SA7295001	1	Rスイッチダイ	REVERSE SWITCH BRACKET	
4	SA4098001	1	アクチュエーター	ACTUATOR	
5	SA4099001	1	Rスイッチパネ	REVERSE SWITCH SPRING	
6	SA1390001	1	Rスイッチクミ	R-SWITCH ASSY	
7	S32907050	1	マイクロスイッチ	MICRO SWITCH	
8	060300606	1	バインド3X6	SCREW BIND M3X6	
9	062400816	2	ナベコ4X8	SCREW PAN M4X8	
10	021400206	2	2シュナット4	NUT 2 M4	
11	062500616	2	ナベコ5X6	SCREW PAN M5X6	
12	062500816	3	ナベコ5X8	SCREW PAN M5X8	
13	SA8008001	1	コードオサエ	CORD HOLDER	
14	062500616	1	ナベコ5X6	SCREW PAN M5X6	
			<-4□□用>	<For "-4□□">	
15	SA1388101	1	コードオサエ	CORD HOLDER	
16	SA1394101	2	コードオサエU3	CORD HOLDER U3	
			<-3□□用>	<For "-3□□">	
17	SA1388101	2	コードオサエ	CORD HOLDER	
18	SA2689101	1	コードオサエ	CORD HOLDER	

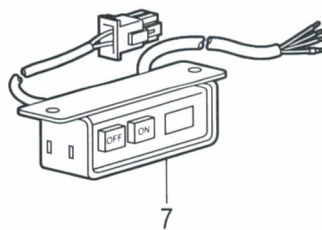
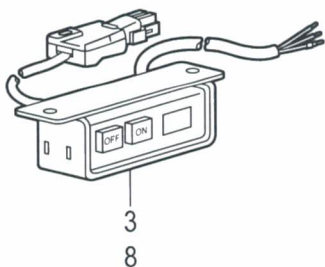
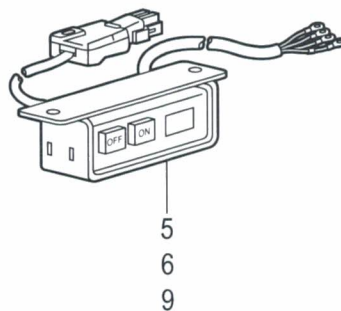
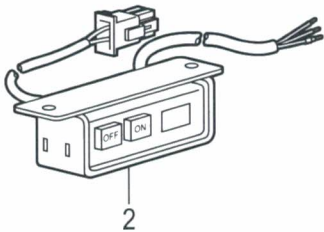
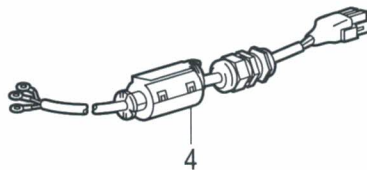
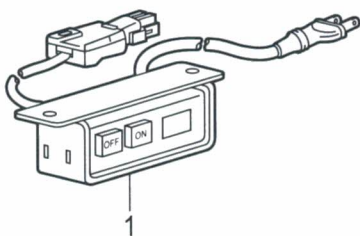

S . 電装品関係 / Power supply equipment mechanism

REF.NO	CODE	Q'TY	品名	NAME OF PARTS	RM
1	J04086001	1	<単相 100V AC用> <日本向用> デンSWクミ1-100V#6	<For Single phase"100V AC"> < For Japan > POWER SWITCH ASSY, 1-100V #6	
2	J04469001	1	<単相 110V AC用> <北米・メキシコ向用> デンSWクミ1-110V#8	<For Single phase"110V AC"> < For USA, Canada & Mexico > POWER SWITCH ASSY, 1-110V #8	
3	J04093001	1	<単相 220V AC用> <一般アジア・北アフリカ向用> デンSWクミ1-240V#6	<For Single phase"220V AC"> < For General of Asia & North africa > POWER SWITCH ASSY, 1-240V #6	
4	J04134001	1	<単相 230V AC CE 用> 電源スイッチ無 <欧州向用> デンPGクミ1-240V#6	<For Single phase"230V AC CE"> Power SW-less < For Europe > POWER PLUG ASSY, 1-240V #6	
5	J04096001	1	<三相 380V AC 用> <一般アジア・北アフリカ向用> デンSWクミ3-400V#6	<For Three phase"380V AC"> < For General of Asia & North africa > POWER SWITCH ASSY, 3-400V #6	
6	J04149001	1	<三相 200V AC 用> <日本向用> デンSWクミ3-200V#6	<For Three phase"200V AC"> < For Japan > POWER SWITCH ASSY, 3-200V #6	
7	J04470001	1	<三相 220V AC 用> <北米・メキシコ向用> デンSWクミ3-240V#8	<For Three phase"220V AC"> < For USA, Canada & Mexico > POWER SWITCH ASSY, 3-240V #8	
8	J04251001	1	<単相 220V AC用> <中国向用> デンSWクミ1-240V#CCC	<For Single phase"220V AC"> < For China > POWER SWITCH ASSY, 1-240V #CCC	
9	J04255001	1	<三相 380V AC 用> <中国向用> デンSWクミ3-400V#CCC	<For Three phase"380V AC"> < For China > POWER SWITCH ASSY, 3-400V #CCC	

T. 電磁押え上げセット関係(オプション部品) / Presser foot lifting set mechanism (Option parts)

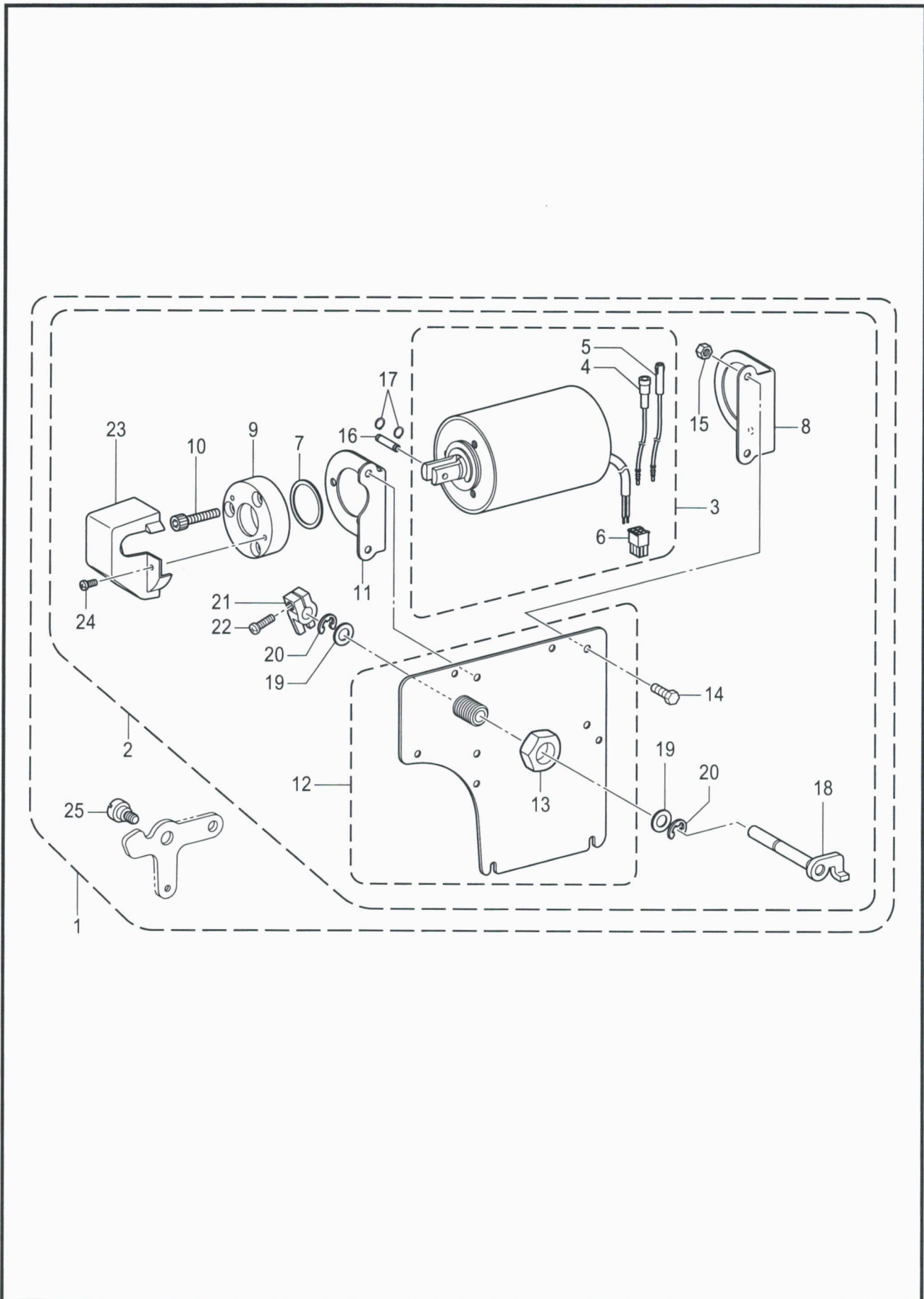

T. 電磁押え上げセット関係 (オプション部品) / Presser foot lifting set mechanism (Option parts)

REF.NO	CODE	Q'TY	品名	NAME OF PARTS	RM
1	SA1397001	1	デンジオサエアゲセットB	SOLENOID P-FOOT LIFTER SET, B	
2	SA1941001	1	デンジオサエアゲクミ	SOLENOID P-FOOT LIFTER ASSY	
3	SA1942001	1	オサエアゲソレノイドクミ	P-FOOT LIFTER SOLENOID ASSY	
4	S38803051	1	Bコード100クミ	B-CORD ASSY 100	
5	S38804050	1	Wコード100クミ	W-CORD ASSY, 100	
6	SA2177001	1	コネクタ5557-6R	CONNECTOR:5557-6R	
7	S16625050	1	ゴムストツパー	RUBBER STOPPER	
8	SA1335001	1	ソレノイドダイR	SOLENOID BASE R	
9	S16629151	1	ソレノイドストツパー	SOLENOID STOPPER	
10	018761832	3	アナボルト595-28X18	BOLT, SOCKET SM5.95-28X18	
11	SA1336001	1	ソレノイドダイL	SOLENOID BASE L	
12	SA1950001	1	ガワイタクミ	REAR PLATE	
13	SA2296001	1	ナツト20	NUT M20	
14	017061216	4	ボルト6X12	BOLT M6X12	
15	021060216	4	2シュナツト6	NUT 2 M6	
16	S16630051	1	ピン	PIN	
17	048050142	2	トメワジクヨウC5	RETAINING RING EXTERNAL C5	
18	SA1332001	1	オサエアゲジク	KNEE LIFTER SHAFT	
19	S20356001	2	ヒラザガネ10	WASHER, PLAIN 10	
20	048080342	2	トメワE8	RETAINING RING E8	
21	SA1338001	1	オサエアゲウデ	PRESSER FOOT LIFTER ARM	
22	062501216	1	ナベコ5X12	SCREW PAN M5X12	
23	S16643009	1	カバー	COVER	
24	062670612	2	ナベコ357-40X6	SCREW PAN SM3.57-40X6	
25	SA2165001	1	ダンネジ6	SHOULDER SCREW, M6	

Z. 付属品関係 / Accessories

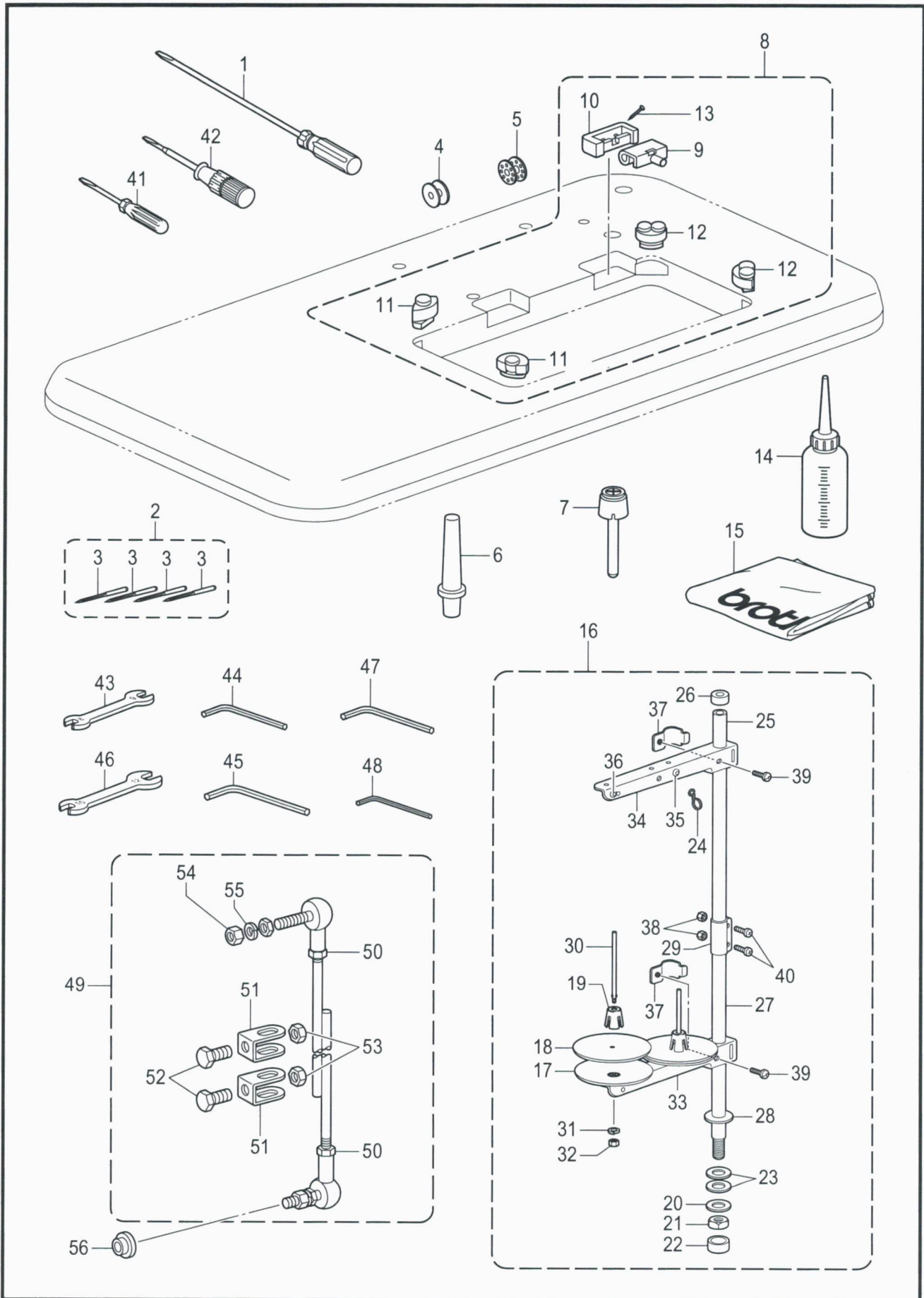

S-7200B-910

Z. 付属品関係 / Accessories

REF.NO	CODE	Q'TY	品名	NAME OF PARTS	RM
1	S17774001	1	ネジマワシ4.7X250	SCREW-DRIVER, 4.7X250	
			<-□□3用>	<For "-□□3">	
2	SA1656011	1	100265ハリ4コイリクミ……<#11>	NEEDLE 4PIECE ASSY, 100265……<#11>	
3	100265031	4	マシンハリDBX1	NEEDLE DBX1	
2	SA1656014	1	100265ハリ4コイリクミ……<#14>	NEEDLE 4PIECE ASSY, 100265……<#14>	
3	100265034	4	マシンハリDBX1	NEEDLE DBX1	
2	SA1752014	1	107415ハリ4コイリクミ……<#14>	NEEDLE 4PIECE ASSY, 107415……<#14>	
3	107415014	4	マシンハリDPX5	NEEDLE, DPX5	
			<-□□5用>	<For "-□□5">	
2	SA1656022	1	100265ハリ4コイリクミ……<#22>	NEEDLE 4PIECE ASSY, 100265……<#22>	
3	100265042	4	マシンハリDBX1	NEEDLE DBX1	
2	SA1752022	1	107415ハリ4コイリクミ……<#22>	NEEDLE 4PIECE ASSY, 107415……<#22>	
3	107415022	4	マシンハリDPX5	NEEDLE, DPX5	
			<-□□S用>	<For "-□□S">	
2	SA1658010	1	S35775ハリ3コイリクミ……<#10>	NEEDLE 3PIECE ASSY, S35775……<#10>	
2	SA1660010	1	S37061ハリ3コイリクミ……<#10>	NEEDLE 3PIECE ASSY, S37061……<#10>	
3	S37061010	3	マシンハリDPX5NS	NEEDLE, DPX5 NS	
			<-□□S用>	<For "-□□S">	
4	146290001	3	ボビン	BOBBIN	
			<-□□5用>	<For "-□□5">	
5	117132001	3	ボビン	BOBBIN	
6	S06055009	1	マクラS	HEAD REST, S	
7	S09634000	1	ヒザアゲオシボウ	KNEE LIFTER COMPLYING BAR	
8	SA1969001	1	ラバ-ヒンジクミ	RUBBER HINGE ASSY	
9	143882001	2	トウブヒンジ	HEAD HINGE	
10	143910009	2	トウブヒンジウケゴム	RUBBER CUSHION	
11	SA1962001	2	トウブシキゴム……<左側用>	HEAD CUSHION……<For left side>	
12	SA1963001	2	トウブシキゴム……<右側用>	HEAD CUSHION……<For right side>	
13	109714000	4	クギ	NAIL	
14	SA7297101	1	オイルタンククミ	OIL TANK ASSY	
15	144226001	1	トウブカバー	HEAD COVER	
16	S02763602	1	イトタテダイクミ2DR	COTTON STAND ASSY 2DR	
17	S51283001	2	ウケザラ	SPOOL STAND BASE	
18	150182000	2	スプ-ルマット	SPOOL MAT	
19	S51282101	2	スプ-ルクツシヨソ	SPOOL CUSHION	
20	150206002	1	ヒラザガネ16	WASHER PLAIN 16	
21	SA6629001	1	6カクナツトM16	NUT M16	
22	150174000	1	コラムキャツブ	COLUMN CAP	
23	S01005000	2	イトタテゴム	RUBBER WASHER	
24	S02747101	1	イトカケバネ	SPRING	
25	150172003	1	コラムパイプ	COLUMN PIPE	
26	150174000	1	コラムキャツブ	COLUMN CAP	
27	150207001	1	コラムパイプネジツキ	COLUMN PIPE W/SCREW	
28	150206000	1	ヒラザガネ16	WASHER PLAIN 16	
29	SA6606001	1	コラムジョイント	COLUMN JOINT	
30	150179002	2	スプ-ルジクB	SPOOL SHAFT B	
31	028050244	2	バネザガネ2-5	WASHER SPRING 2-5	
32	021500104	2	1シュナツト5	NUT 1 M5	
33	SA6607001	1	スプ-ルホルダ-2	SPOOL HOLDER 2	
34	SA6607001	1	スプ-ルホルダ-2	SPOOL HOLDER 2	
35	150183000	2	イトカケハンガ-ダイ	THREAD HANGER BASE	
36	142990001	2	スレツドブツシュ	THREAD BUSH	
37	SA6609001	2	スプ-ルホルダ-ササエ	SPOOL HOLDER SUPPORTER	
38	021500104	2	1シュナツト5	NUT 1 M5	
39	062061604	2	ナベコ6X16	SCREW PAN M6X16	
40	062501404	2	ナベコ5X14	SCREW PAN M5X14	
41	142443001	1	ネジマワシ1.9X52	SCREW-DRIVER, 1.9X52	
42	118837001	1	ネジマワシ3.4X70	SCREW-DRIVER, 3.4X70	
43	100887001	1	スパナ8X9	WRENCH, 8X9	

Z. 付属品関係 / Accessories

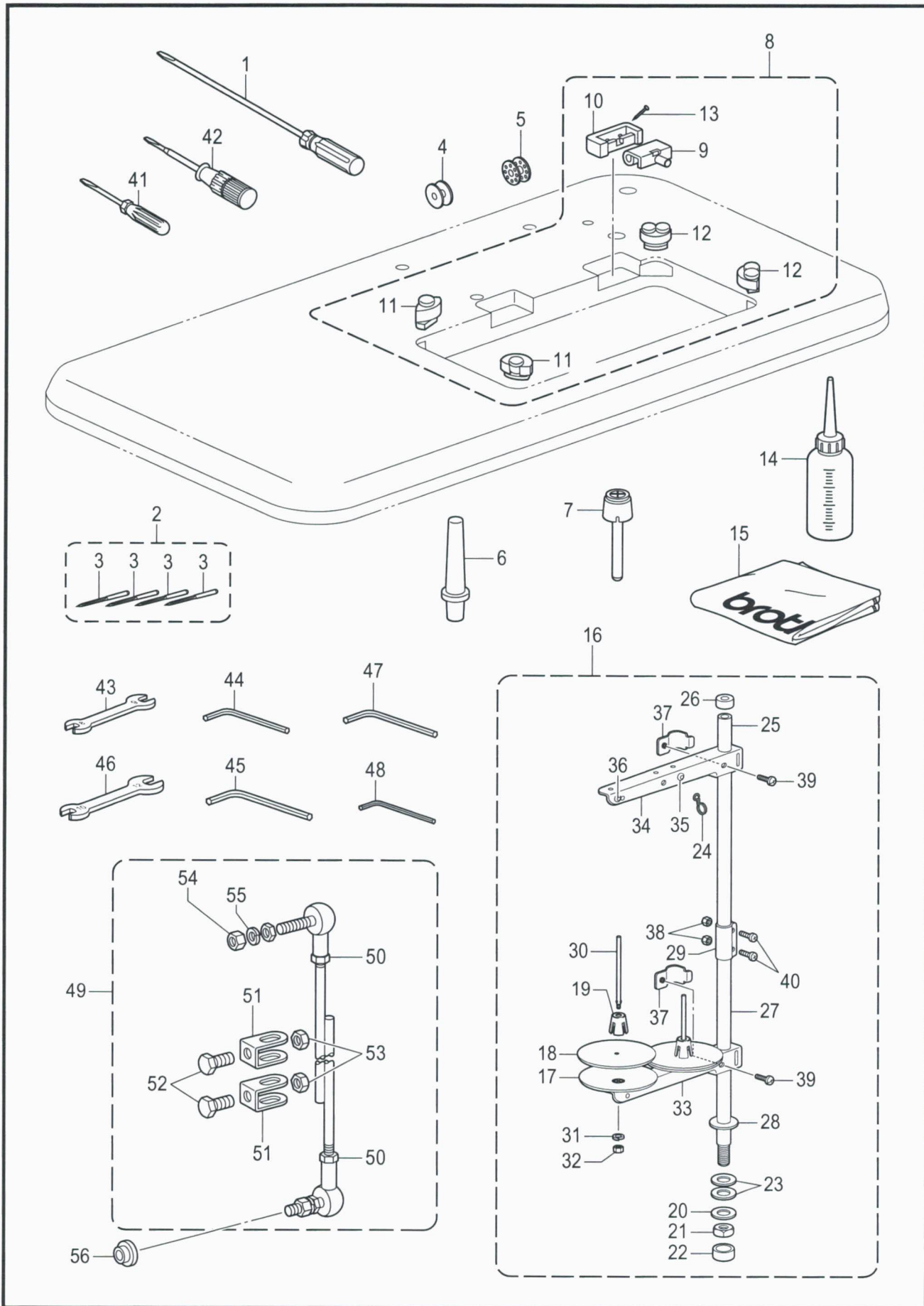

S-7200B-910

Z. 付属品関係 / Accessories

REF.NO	CODE	Q'TY	品名	NAME OF PARTS	RM
44	142002001	1	6カクボウスパナ2	HEXAGONAL WRENCH, 2	
45	142721001	1	6カクボウスパナ3	HEXAGONAL WRENCH, 3	
46	107780001	1	スパナ10X12	WRENCH, 10X12	
47	154125001	1	6カクボウスパナ2.5	HEXAGONAL WRENCH, 2.5	
48	S07783001	1	6カクボウスパナ1.5	HEXAGONAL WRENCH, 1.5	
			<オプション用>	<OPTION PARTS>	
49	S40765001	1	レンケツカンクミ	CONNECTING ROD ASSY	
50	021060106	2	1シュナット6	NUT 1 M6	
51	119101001	2	レンカンダキ	CONNECTING ROD CLAMP	
52	017841606	2	ボルト7.94-18X16	BOLT SM7.94-18X16	
53	133643006	2	6カクナツト7.94-18	NUT SM7.94-18	
54	021060106	2	1シュナット6	NUT 1 M6	
55	028060243	2	バネザガネ2-6	WASHER, SPRING 2-6	
56	114859001	2	レンカンカラ-	COLLAR	

Sp1 . 仕様別部品一覧表 (日本向) / Different parts list (For Japan)

REF.NO	品名 / Name of parts	仕様 / Specification		
		微量給油タイプ / Minimum lubrication type		
		-□03	-□05	仕向 / Destination
中厚物用 / Medium-weight materials	厚物用 / Heavy-weight materials			
B-49	針棒 / Needle bar	SA1133001	SA1137001	日本向 / For Japan
B-84	ミシン針 / Needle	100265031	100265042	
B-83	針板 / Needle plate	145971101	147245101	
C-7	押えバネ / Presser bar spring	S13561101	141728001	
C-9	押え組 / Presser foot assy	153037201	145157101	
D-89	送り歯 / Feed dog	S02742001	S02743001	
G-20	内かま止め / Hook stopper	S02602001	159324001	
G-30	かま箱組 / Rotary hook assy, w/box	SA7686002	SA7688001	
G-27	ボビン / Bobbin	146290001	---	
G-28	ボビン / Bobbin	---	117132001	

REF.NO	品名 / Name of parts	仕様 / Specification		
		セミドライタイプ / Semi dry type		
		-□3S	-□33	仕向 / Destination
薄物・難素材用 / Light-weight materials & for Difficult-to-sew materials	中厚物用 / Medium-weight materials			
B-49	針棒 / Needle bar	SA1135001	SA7241001	日本向 / For Japan
B-84	ミシン針 / Needle	S35775010	100265031	
B-83	針板 / Needle plate	S35776201	145971101	
C-7	押えバネ / Presser bar spring	147514001	S13561101	
C-9	押え組 / Presser foot assy	S35777101	153037201	
D-91, D-89	送り歯 / Feed dog	S02748001	S02742001	
G-20	内かま止め / Hook stopper	S02602001	←	
G-30	かま箱組 / Rotary hook assy, w/box	SA7687001	SA7686002	
G-27	ボビン / Bobbin	146290001	←	

REF.NO	品名 / Name of parts	仕様 / Specification		
		完全ドライタイプ / Complete dry type		
		-□5S	-□53	仕向 / Destination
薄物・難素材用 / Light-weight materials & for Difficult-to-sew materials	中厚物用 / Medium-weight materials			
B-49	針棒 / Needle bar	SA1135001	←	日本向 / For Japan
B-84	ミシン針 / Needle	S35775010	100265031	
B-83	針板 / Needle plate	S35776201	145971101	
C-7	押えバネ / Presser bar spring	147514001	S13561101	
C-9	押え組 / Presser foot assy	S35777101	153037201	
D-91, D-89	送り歯 / Feed dog	S02748001	S02742001	
G-20	内かま止め / Hook stopper	S02602001	←	
G-30	かま箱組 / Rotary hook assy, w/box	S52936001	←	
G-27	ボビン / Bobbin	146290001	←	

S-7200B-Sp1

Sp2 . 仕様別部品一覧表 (アメリカ向) / Different parts list (For USA)

REF.NO	品名 / Name of parts	仕様 / Specification		仕向 / Destination
		微量給油タイプ / Minimum lubrication type		
		-□03 中厚物用 / Medium-weight materials	-□05 厚物用 / Heavy-weight materials	
B-49	針棒 / Needle bar	SA1133001	SA1137001	USA向 / For USA
B-84	ミシン針 / Needle	100265034	100265042	
B-83	針板 / Needle plate	111859301	150792001	
C-7	押えバネ / Presser bar spring	S13561101	141728001	
C-9	押え組 / Presser foot assy	153037201	150789101	
D-90	送り歯 / Feed dog	SA2345001	150793001	
G-20	内かま止め / Hook stopper	S02602001	159324001	
G-30	かま箱組 / Rotary hook assy, w/box	SA7686002	SA7688001	
G-27	ボビン / Bobbin	146290001	---	
G-28	ボビン / Bobbin	---	117132001	

REF.NO	品名 / Name of parts	仕様 / Specification		仕向 / Destination
		セミドライタイプ / Semi dry type		
		-□3S 薄物・難素材用 / Light-weight materials & for Difficult-to-sew materials	-□33 中厚物用 / Medium-weight materials	
B-49	針棒 / Needle bar	SA1135001	SA7241001	USA向 / For USA
B-84	ミシン針 / Needle	S35775010	100265034	
B-83	針板 / Needle plate	S03883201	111859301	
C-7	押えバネ / Presser bar spring	147514001	S13561101	
C-9	押え組 / Presser foot assy	S35777101	153037201	
D-90	送り歯 / Feed dog	SA2346001	SA2345001	
G-20	内かま止め / Hook stopper	S02602001	←	
G-30	かま箱組 / Rotary hook assy, w/box	SA7687001	SA7686002	
G-27	ボビン / Bobbin	146290001	←	

REF.NO	品名 / Name of parts	仕様 / Specification		仕向 / Destination
		完全ドライタイプ / Complete dry type		
		-□5S 薄物・難素材用 / Light-weight materials & for Difficult-to-sew materials	-□53 中厚物用 / Medium-weight materials	
B-49	針棒 / Needle bar	SA1135001	←	USA向 / For USA
B-84	ミシン針 / Needle	S35775010	100265034	
B-83	針板 / Needle plate	S03883201	111859301	
C-7	押えバネ / Presser bar spring	147514001	S13561101	
C-9	押え組 / Presser foot assy	S35777101	153037201	
D-92, D-90	送り歯 / Feed dog	SA2346001	SA2345001	
G-20	内かま止め / Hook stopper	S02602001	←	
G-30	かま箱組 / Rotary hook assy, w/box	S52936001	←	
G-27	ボビン / Bobbin	146290001	←	

S-7200B-Sp2

Sp3 . 仕様別部品一覧表 (中国向) / Different parts list (For China)

REF.NO	品名 / Name of parts	仕様 / Specification		
		微量給油タイプ / Minimum lubrication type		
		-□03	-□05	仕向 / Destination
中厚物用 / Medium-weight materials	厚物用 / Heavy-weight materials			
B-49	針棒 / Needle bar	SA1133001	SA1137001	中国向 / For China
B-84	ミシン針 / Needle	100265034	100265042	
B-83	針板 / Needle plate	111859301	150792101	
C-7	押えバネ / Presser bar spring	S13561101	141728001	
C-9	押え組 / Presser foot assy	153037201	150789101	
D-90	送り歯 / Feed dog	SA2345001	150793001	
G-20	内かま止め / Hook stopper	S02602001	159324001	
G-30	かま箱組 / Rotary hook assy, w/box	SA7686002	SA7688001	
G-27	ボビン / Bobbin	146290001	---	
G-28	ボビン / Bobbin	---	117132001	

REF.NO	品名 / Name of parts	仕様 / Specification		
		セミドライタイプ / Semi dry type		
		-□3S	-□33	仕向 / Destination
薄物・難素材用 / Light-weight materials & for Difficult-to-sew materials	中厚物用 / Medium-weight materials			
B-49	針棒 / Needle bar	SA1135001	SA7241001	中国向 / For China
B-84	ミシン針 / Needle	S35775010	100265034	
B-83	針板 / Needle plate	S03883201	111859301	
C-7	押えバネ / Presser bar spring	147514001	S13561101	
C-9	押え組 / Presser foot assy	S35777101	153037201	
D-92, D-90	送り歯 / Feed dog	SA2346001	SA2345001	
G-20	内かま止め / Hook stopper	S02602001	←	
G-30	かま箱組 / Rotary hook assy, w/box	SA7687001	SA7686002	
G-27	ボビン / Bobbin	146290001	←	

REF.NO	品名 / Name of parts	仕様 / Specification		
		完全ドライタイプ / Complete dry type		
		-□5S	-□53	仕向 / Destination
薄物・難素材用 / Light-weight materials & for Difficult-to-sew materials	中厚物用 / Medium-weight materials			
B-49	針棒 / Needle bar	SA1135001	←	中国向 / For China
B-84	ミシン針 / Needle	S35775010	100265034	
B-83	針板 / Needle plate	S03883201	111859301	
C-7	押えバネ / Presser bar spring	147514001	S13561101	
C-9	押え組 / Presser foot assy	S35777101	153037201	
D-92, D-90	送り歯 / Feed dog	SA2346001	SA2345001	
G-20	内かま止め / Hook stopper	S02602001	←	
G-30	かま箱組 / Rotary hook assy, w/box	S52936001	←	
G-27	ボビン / Bobbin	146290001	←	

S-7200B-Sp3

Sp4 . 仕様別部品一覧表 (輸出一般向) / Different parts list (For General export)

REF.NO	品名 / Name of parts	仕様 / Specification		
		微量給油タイプ / Minimum lubrication type		
		-□03	-□05	仕向 / Destination
		中厚物用 / Medium-weight materials	厚物用 / Heavy-weight materials	
B-49	針棒 / Needle bar	SA1133001	SA1137001	輸出一般向 / For General export
B-84	ミシン針 / Needle	100265034	100265042	
B-83	針板 / Needle plate	111859301	150792101	
C-7	押えバネ / Presser bar spring	S13561101	141728001	
C-9	押え組 / Presser foot assy	153037201	150789101	
D-90	送り歯 / Feed dog	SA2345001	150793001	
G-20	内かま止め / Hook stopper	S02602001	159324001	
G-30	かま箱組 / Rotary hook assy, w/box	SA7686002	SA7688001	
G-27	ボビン / Bobbin	146290001	---	
G-28	ボビン / Bobbin	---	117132001	

REF.NO	品名 / Name of parts	仕様 / Specification		
		セミドライタイプ / Semi dry type		
		-□3S	-□33	仕向 / Destination
		薄物・難素材用 / Light-weight materials & for Difficult-to-sew materials	中厚物用 / Medium-weight materials	
B-49	針棒 / Needle bar	SA1135001	SA7241001	輸出一般向 / For General export
B-84	ミシン針 / Needle	S35775010	100265034	
B-83	針板 / Needle plate	S03883201	111859301	
C-7	押えバネ / Presser bar spring	147514001	S13561101	
C-9	押え組 / Presser foot assy	S35777101	153037201	
D-92, D-90	送り歯 / Feed dog	SA2346001	SA2345001	
G-20	内かま止め / Hook stopper	S02602001	←	
G-30	かま箱組 / Rotary hook assy, w/box	SA7687001	SA7686002	
G-27	ボビン / Bobbin	146290001	←	

REF.NO	品名 / Name of parts	仕様 / Specification		
		完全ドライタイプ / Complete dry type		
		-□5S	-□53	仕向 / Destination
		薄物・難素材用 / Light-weight materials & for Difficult-to-sew materials	中厚物用 / Medium-weight materials	
B-49	針棒 / Needle bar	SA1135001	←	輸出一般向 / For General export
B-84	ミシン針 / Needle	S35775010	100265034	
B-83	針板 / Needle plate	S03883201	111859301	
C-7	押えバネ / Presser bar spring	147514001	S13561101	
C-9	押え組 / Presser foot assy	S35777101	153037201	
D-92, D-90	送り歯 / Feed dog	SA2346001	SA2345001	
G-20	内かま止め / Hook stopper	S02602001	←	
G-30	かま箱組 / Rotary hook assy, w/box	S52936001	←	
G-27	ボビン / Bobbin	146290001	←	

S-7200B-Sp4

Sp5 . 仕様別部品一覧表 (欧州・カナダ向) / Different parts list (For Europe & Canada)

REF.NO	品名 / Name of parts	仕様 / Specification		
		微量給油タイプ / Minimum lubrication type		仕向 / Destination
		-□03	-□05	
中厚物用 / Medium-weight materials	厚物用 / Heavy-weight materials			
B-49	針棒 / Needle bar	SA1134001	SA1137001	欧州・カナダ向 / For Europe & Canada
B-84	ミシン針 / Needle	107415014	107415022	
B-83	針板 / Needle plate	111859301	150792001	
C-7	押えバネ / Presser bar spring	S13561101	141728001	
C-10	押え組 / Presser foot assy	SA2836101	SA2837101	
D-90	送り歯 / Feed dog	SA2345001	150793001	
G-20	内かま止め / Hook stopper	S02602001	159324001	
G-30	かま箱組 / Rotary hook assy, w/box	SA7686002	SA7688001	
G-27	ボビン / Bobbin	146290001	---	
G-28	ボビン / Bobbin	---	117132001	

REF.NO	品名 / Name of parts	仕様 / Specification		
		セミドライタイプ / Semi dry type		仕向 / Destination
		-□3S	-□33	
薄物・難素材用 / Light-weight materials & for Difficult-to-sew materials	中厚物用 / Medium-weight materials			
B-49	針棒 / Needle bar	SA1136001	SA7240001	欧州・カナダ向 / For Europe & Canada
B-84	ミシン針 / Needle	S37061010	107415014	
B-83	針板 / Needle plate	S03883201	111859301	
C-7	押えバネ / Presser bar spring	147514001	S13561101	
C-10	押え組 / Presser foot assy	SA2433101	SA2836101	
D-92, D-90	送り歯 / Feed dog	SA2346001	SA2345001	
G-20	内かま止め / Hook stopper	S02602001	←	
G-30	かま箱組 / Rotary hook assy, w/box	SA7687001	SA7686002	
G-27	ボビン / Bobbin	146290001	←	







REF.NO	品名 / Name of parts	仕様 / Specification		
		完全ドライタイプ / Complete dry type		仕向 / Destination
		-□5S	-□53	
薄物・難素材用 / Light-weight materials & for Difficult-to-sew materials	中厚物用 / Medium-weight materials			
B-49	針棒 / Needle bar	SA1136001	←	欧州・カナダ向 / For Europe & Canada
B-84	ミシン針 / Needle	S37061010	107415014	
B-83	針板 / Needle plate	S03883201	111859301	
C-7	押えバネ / Presser bar spring	147514001	S13561101	
C-10	押え組 / Presser foot assy	SA2433101	SA2836101	
D-92, D-90	送り歯 / Feed dog	SA2346001	SA2345001	
G-20	内かま止め / Hook stopper	S02602001	←	
G-30	かま箱組 / Rotary hook assy, w/box	S52936001	←	
G-27	ボビン / Bobbin	146290001	←	

S-7200B-Sp5

Ga1 . ゲージ部品一覧表 (薄・中厚物用 : 3枚歯) /

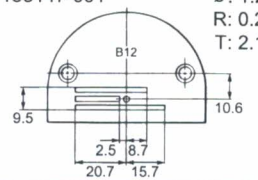
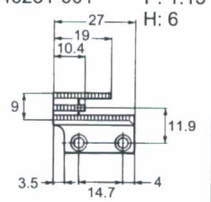
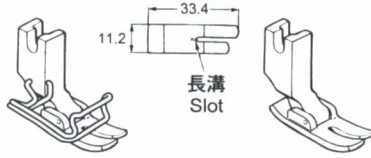
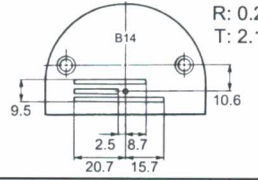
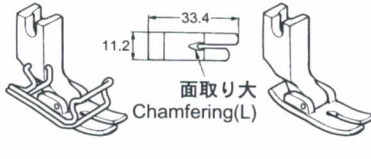
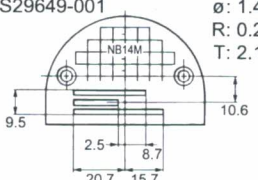
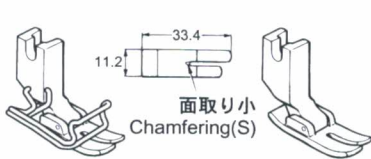
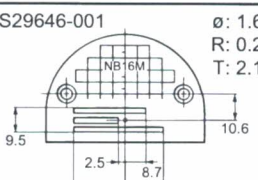
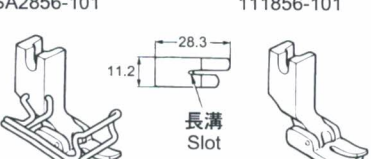
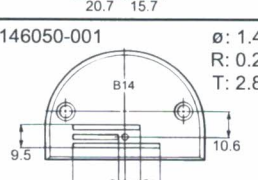
Gauge parts list (Light & medium-weight materials : 3ROW)

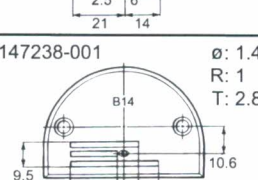
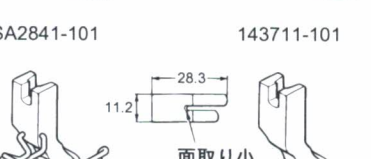
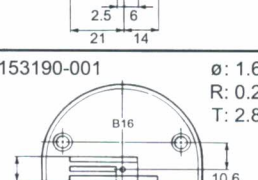
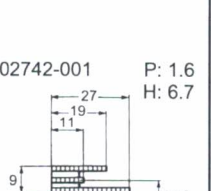
3枚歯 / 3ROW

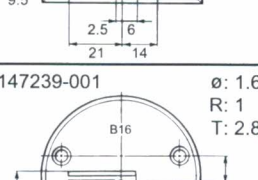
用途 Application	針板 Needle plate		送り歯 Feed dog	押え組 Presser foot assy		
	記号 Mark					
薄・中厚物用 Light & medium-weight materials	B12	153147-001 		SA2836-101	153037-201 	
	B14	146233-001 		SA2839-101	113280-101 	
	NB14M	S29649-001 		SA2842-101	147531-101 	
	NB16M	S29646-001 		SA2856-101	111856-101 	
	B14	146050-001 		S07649-001	SA2840-101	140957-101 
	B14	147238-001 		S02742-001	SA2841-101	143711-101 
	B16	153190-001 			S01904-001 	
	B16	147239-001 				

Ga2 . ゲージ部品一覧表 (薄・中厚物用 : 3枚歯)/

Gauge parts list (Light & medium-weight materials : 3ROW)

3枚歯 / 3ROW

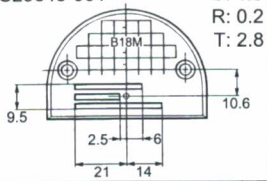
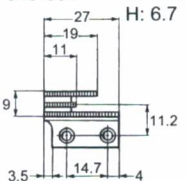
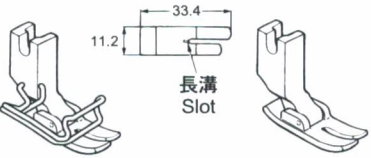
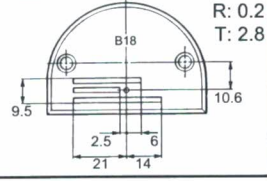
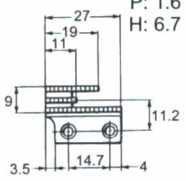
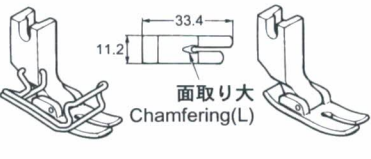
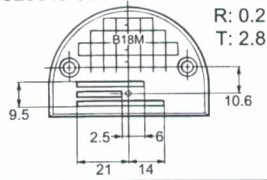
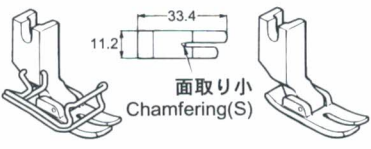
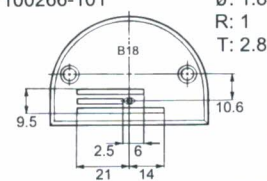
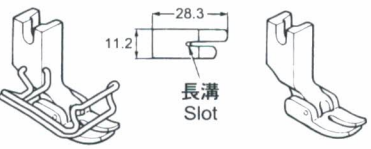
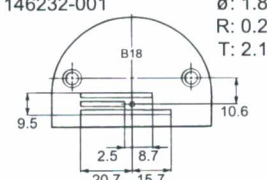
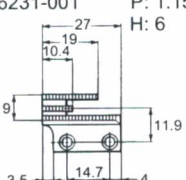
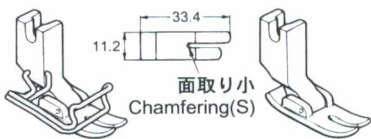
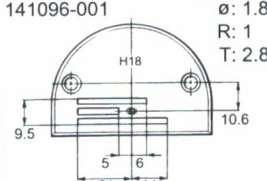
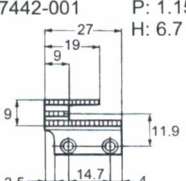
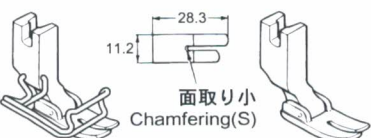
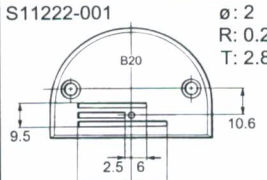
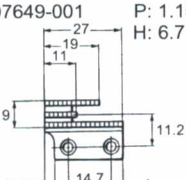
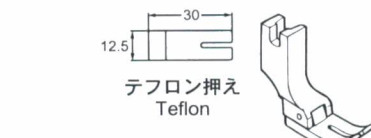
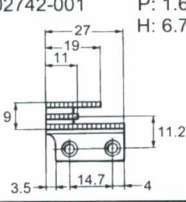
用途 Application	針板 Needle plate 記号 Mark	送り歯 Feed dog	押え組 Presser foot assy
薄・中厚物用 Light & medium-weight materials	B18M S29645-001  ø: 1.8 R: 0.2 T: 2.8 Dimensions: 9.5, 2.5, 6, 21, 14, 10.6	S07649-001 P: 1.15  H: 6.7 Dimensions: 27, 19, 11, 9, 11.2, 3.5, 14.7, 4	SA2836-101 153037-201  11.2, 33.4 長溝 Slot
中厚物用 medium-weight materials	B18 145971-101  ø: 1.8 R: 0.2 T: 2.8 Dimensions: 9.5, 2.5, 6, 21, 14, 10.6	S02742-001 P: 1.6  H: 6.7 Dimensions: 27, 19, 11, 9, 11.2, 3.5, 14.7, 4	SA2839-101 113280-101  11.2, 33.4 面取り大 Chamfering(L)
	B18M S29645-001  ø: 1.8 R: 0.2 T: 2.8 Dimensions: 9.5, 2.5, 6, 21, 14, 10.6		SA2842-101 147531-101  11.2, 33.4 面取り小 Chamfering(S)
	B18 100266-101  ø: 1.8 R: 1 T: 2.8 Dimensions: 9.5, 2.5, 6, 21, 14, 10.6		SA2856-101 111856-101  11.2, 28.3 長溝 Slot
	B18 146232-001  ø: 1.8 R: 0.2 T: 2.1 Dimensions: 9.5, 2.5, 8.7, 20.7, 15.7, 10.6	146231-001 P: 1.15  H: 6 Dimensions: 27, 19, 10.4, 9, 11.9, 3.5, 14.7, 4	SA2840-101 140957-101  11.2, 33.4 面取り小 Chamfering(S)
	H18 141096-001  ø: 1.8 R: 1 T: 2.8 Dimensions: 9.5, 5, 6, 21, 14, 10.6	117442-001 P: 1.15  H: 6.7 Dimensions: 27, 19, 9, 9, 11.9, 3.5, 14.7, 4	SA2841-101 143711-101  11.2, 28.3 面取り小 Chamfering(S)
	B20 S11222-001  ø: 2 R: 0.2 T: 2.8 Dimensions: 9.5, 2.5, 6, 21, 14, 10.6	S07649-001 P: 1.15  H: 6.7 Dimensions: 27, 19, 11, 9, 11.2, 3.5, 14.7, 4	S01904-001  12.5, 30 テフロン押え Teflon
		S02742-001 P: 1.6  H: 6.7 Dimensions: 27, 19, 11, 9, 11.2, 3.5, 14.7, 4	

Ga3 . ゲージ部品一覧表 (厚物用 : 3枚歯) /

Gauge parts list (Heavy-weight materials : 3ROW)

3枚歯 / 3ROW

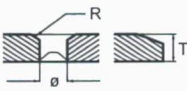
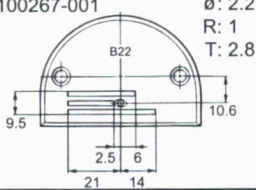
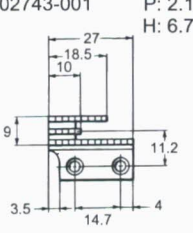
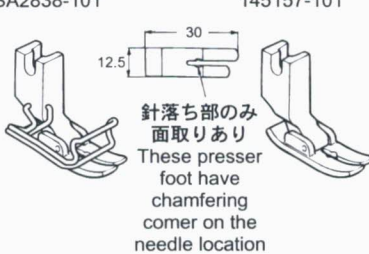
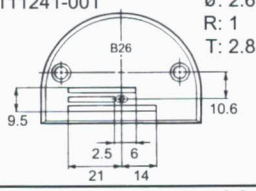
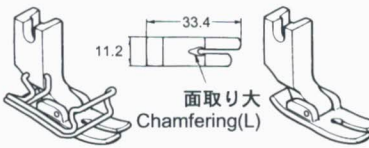
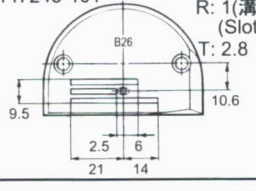
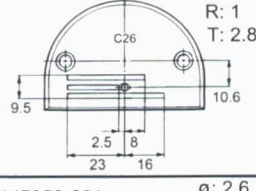
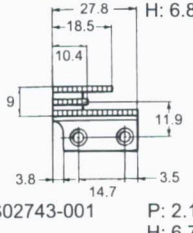
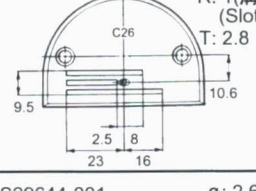
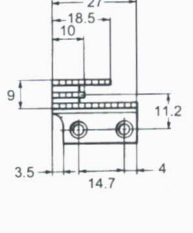
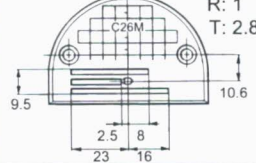
用途 Application	針板 Needle plate		送り歯 Feed dog	押え組 Presser foot assy			
	記号 Mark						
厚物用 Heavy-weight materials	B22			 <p>針落ち部のみ 面取りあり These presser foot have chamfering corner on the needle location</p>			
	B26				 <p>面取り大 Chamfering(L)</p>		
	B26						
	C26						
	C26						
	C26M						

S-7200B-Ga3

- ◎ ネジ穴中心から歯部中心まで11.9mm の送り歯を使用する場合、水平送り台腕と上下送り台腕を0.7mm左側へ移動させて下さい。
- ◎ If a feed dog measuring 11.9mm from the screw hole center to tooth center is be use, shift the feed bar crank and feed lifting crank 0.7mm to the left .

Ga4 . ゲージ部品一覧表 (難素材・新素材用 : 4枚歯) /

Gauge parts list (Difficult-to-sew materials & Shin-gosen : 4ROW)

4枚歯 / 4ROW

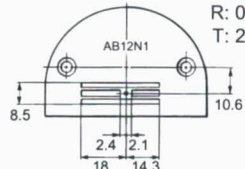
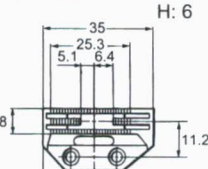
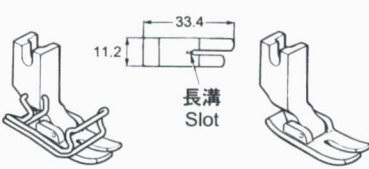
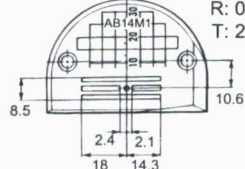
用途 Application	針板 Needle plate 記号 Mark	送り歯 Feed dog	押え組 Presser foot assy
難素材用 Difficult-to-sew materials	AB12N1 S38760-001 ϕ : 1.2 R: 0.2 T: 2.1 	S02748-001 P: 0.9 H: 6 	SA2433-101 S35777-101 
新素材用 Shin-gosen	AB14M1 S35776-101 ϕ : 1.4 R: 0.2 T: 2.1 		

S-7200B-Ga4

Ga5 . ゲージ部品一覧表 (薄・中厚物用 : 4枚歯)/

Gauge parts list (Light & medium-weight materials : 4ROW)

4枚歯 / 4ROW

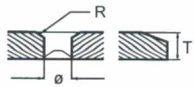
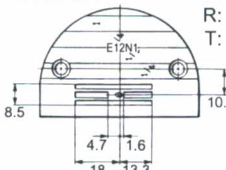
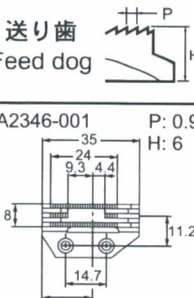
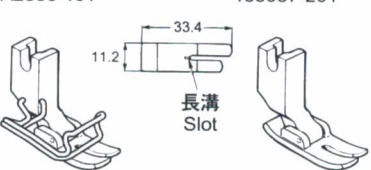
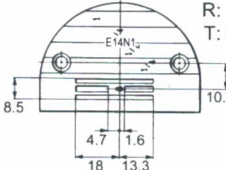
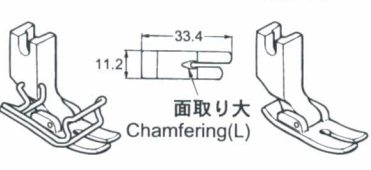
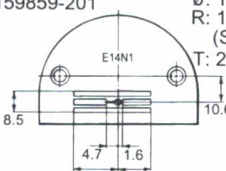
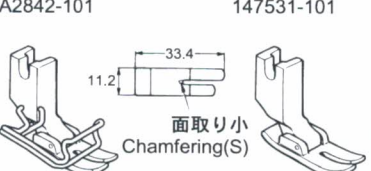
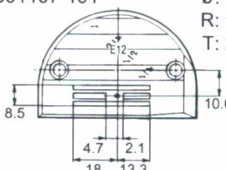
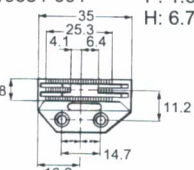
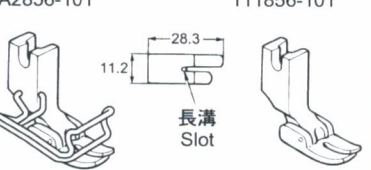
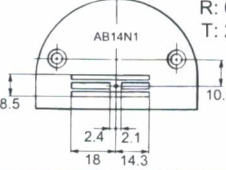
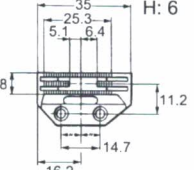
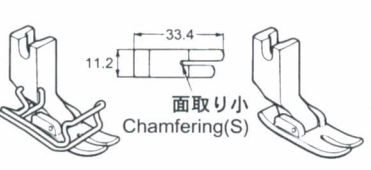
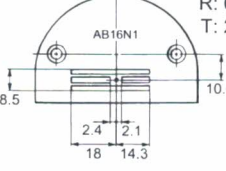
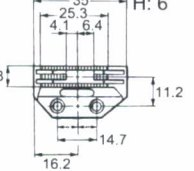
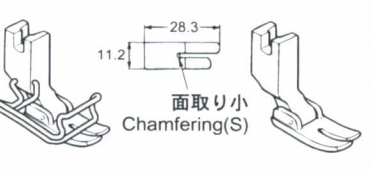
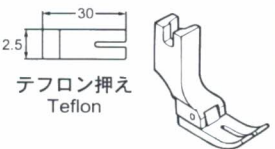
用途 Application	針板 Needle plate		送り歯 Feed dog	押え組 Presser foot assy	
	記号 Mark				
薄・中厚物用 Light & medium-weight materials	E12N1	S03882-201  ø: 1.2 R: 1 T: 2.1	SA2346-001  P: 0.9 H: 6	SA2836-101 153037-201  長溝 Slot	
	E14N1	S03883-201  ø: 1.4 R: 1 T: 2.1		SA2839-101 113280-101  面取り大 Chamfering(L)	
	E14N1	159859-201  ø: 1.4 R: 1(溝) (Slot) T: 2.1		SA2842-101 147531-101  面取り小 Chamfering(S)	
	E12	S01107-101  ø: 1.2 R: 1 T: 2.1	S13684-001  P: 1.6 H: 6.7	SA2856-101 111856-101  長溝 Slot	
			送りピッチ 4mm 以下で使用 Use the feed dog and needle plate with a stitch length of 4mm or less		
	AB14N1	S02999-201  ø: 1.4 R: 0.2 T: 2.1	S02748-001  P: 0.9 H: 6	SA2840-101 140957-101  面取り小 Chamfering(S)	
AB16N1	S03000-201  ø: 1.4 R: 0.2 T: 2.1	S02744-001  P: 1.15 H: 6	SA2841-101 143711-101  面取り小 Chamfering(S)		
			S01904-001  テフロン押え Teflon		

Ga6 . ゲージ部品一覧表 (薄・中厚物用 : 4枚歯) /

Gauge parts list (Light & medium-weight materials : 4ROW)

4枚歯 / 4ROW





用途 Application	針板 Needle plate		送り歯 Feed dog	押え組 Presser foot assy	
	記号 Mark				
薄・中厚物用 Light & medium-weight materials	AB16	156115-001 ø: 1.6 R: 0.2 T: 2.8	S13684-001 P: 1.6 H: 6.7	SA2836-101 	153037-201
	AB18	156116-001 ø: 1.8 R: 0.2 T: 2.8		SA2839-101 	113280-101
	AB18M	S31910-001 ø: 1.8 R: 0.2 T: 2.8		SA2842-101 	147531-101
	E16N1	S03884-301 ø: 1.6 R: 1 T: 2.1	SA2346-001 P: 0.9 H: 6	SA2856-101 	111856-101
	E16M1	S29648-101 ø: 1.6 R: 1 T: 2.1	SA2345-001 P: 1.15 H: 6	SA2840-101 	140957-101
	E18N1	111859-301 ø: 1.8 R: 1 T: 2.1		SA2841-101 	143711-101
	E18M1	S29647-101 ø: 1.8 R: 1 T: 2.1			S01904-001

S-7200B-Ga6

Ga7 . ゲージ部品一覧表 (薄・中厚物用 : 4枚歯) /

Gauge parts list (Light & medium-weight materials : 4ROW)

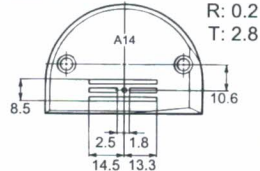
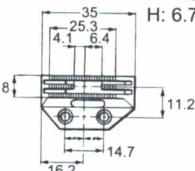
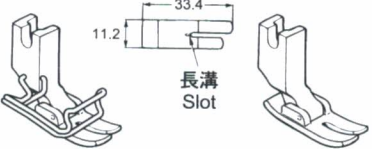
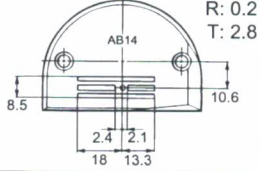
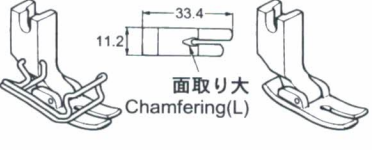
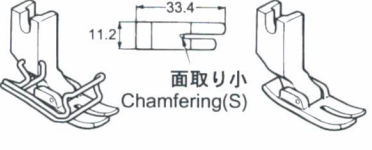
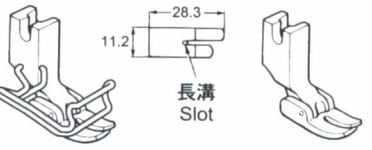
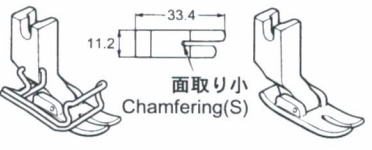
4枚歯 / 4ROW

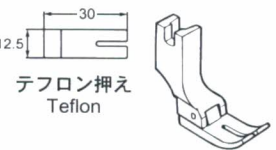

用途 Application	針板 Needle plate		送り歯 Feed dog	押え組 Presser foot assy	
	記号 Mark				
薄・中厚物用 Light & medium-weight materials	A14	155676-001 	S13684-001 	SA2836-101	153037-201 
	AB14	156114-001 		SA2839-101	113280-101 
				SA2842-101	147531-101 
				SA2856-101	111856-101 
				SA2840-101	140957-101 
				SA2841-101	143711-101 
					S01904-001 

S-7200B-Ga7

Ga8 . ゲージ部品一覧表 (薄・中厚物用 : 4枚歯) /

Gauge parts list (Light & medium-weight materials : 4ROW)

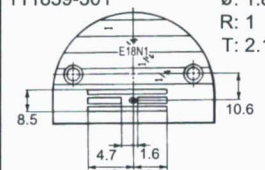
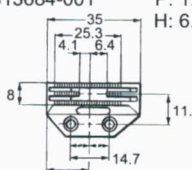
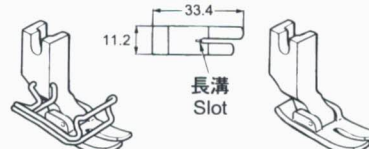
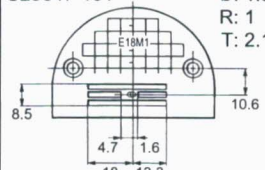
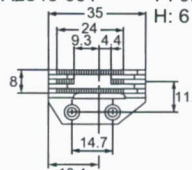
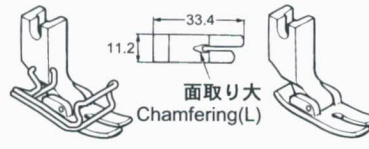
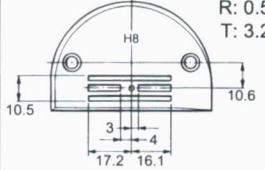
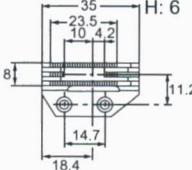
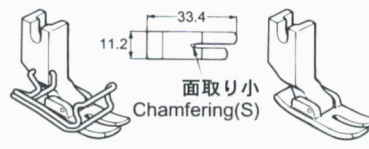
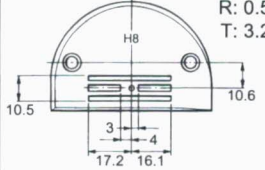
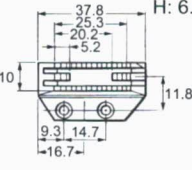
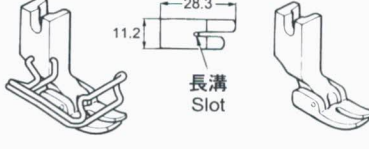
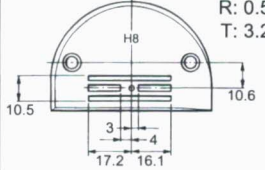
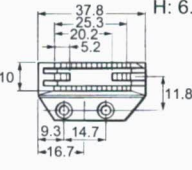
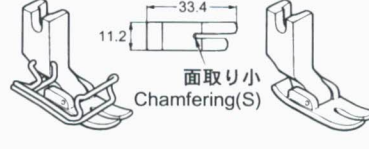
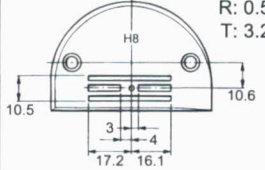
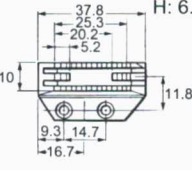
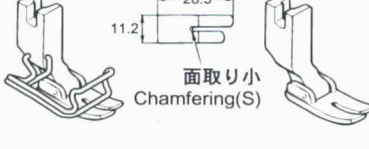
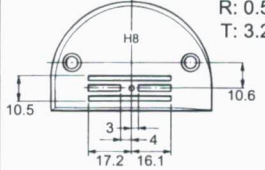
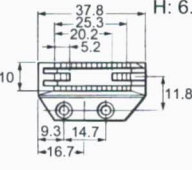
4枚歯 / 4ROW

用途 Application	針板 Needle plate 記号 Mark	送り歯 Feed dog	押え組 Presser foot assy
薄・中厚物用 Light & medium-weight materials	E18N1 111859-301  ø: 1.8 R: 1 T: 2.1 8.5, 10.6, 4.7, 1.6, 18, 13.3	S13684-001 P: 1.6  H: 6.7 35, 25.3, 4.1, 6.4, 8, 11.2, 14.7, 16.2	SA2836-101 153037-201  11.2, 33.4 長溝 Slot
	E18M1 S29647-101  ø: 1.8 R: 1 T: 2.1 8.5, 10.6, 4.7, 1.6, 18, 13.3	SA2346-001 P: 0.9  H: 6 35, 24, 9.3, 4.4, 8, 11.2, 14.7, 18.4	SA2839-101 113280-101  11.2, 33.4 面取り大 Chamfering(L)
	H18 S30103-001  ø: 1.8 R: 0.5 T: 3.2 10.5, 10.6, 3, 4, 17.2, 16.1	SA2345-001 P: 1.15  H: 6 35, 23.5, 10, 4.2, 8, 11.2, 14.7, 18.4	SA2842-101 147531-101  11.2, 33.4 面取り小 Chamfering(S)
	H18 S30103-001  ø: 1.8 R: 0.5 T: 3.2 10.5, 10.6, 3, 4, 17.2, 16.1	S25822-001 P: 1.8  H: 6.8 37.8, 25.3, 20.2, 5.2, 10, 11.8, 9.3, 14.7, 16.7	SA2856-101 111856-101  11.2, 28.3 長溝 Slot
	H18 S30103-001  ø: 1.8 R: 0.5 T: 3.2 10.5, 10.6, 3, 4, 17.2, 16.1	S25822-001 P: 1.8  H: 6.8 37.8, 25.3, 20.2, 5.2, 10, 11.8, 9.3, 14.7, 16.7	SA2840-101 140957-101  11.2, 33.4 面取り小 Chamfering(S)
	H18 S30103-001  ø: 1.8 R: 0.5 T: 3.2 10.5, 10.6, 3, 4, 17.2, 16.1	S25822-001 P: 1.8  H: 6.8 37.8, 25.3, 20.2, 5.2, 10, 11.8, 9.3, 14.7, 16.7	SA2841-101 143711-101  11.2, 28.3 面取り小 Chamfering(S)
	H18 S30103-001  ø: 1.8 R: 0.5 T: 3.2 10.5, 10.6, 3, 4, 17.2, 16.1	S25822-001 P: 1.8  H: 6.8 37.8, 25.3, 20.2, 5.2, 10, 11.8, 9.3, 14.7, 16.7	S01904-001  12.5, 30 テフロン押え Teflon

S-7200B-Ga8

Ga9 . ゲージ部品一覧表 (厚物用 : 4枚歯) /



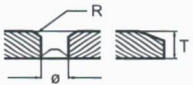
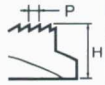
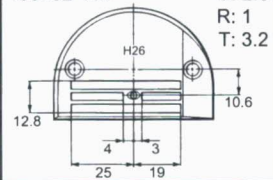
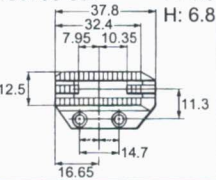
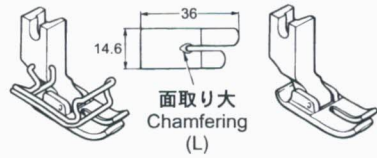
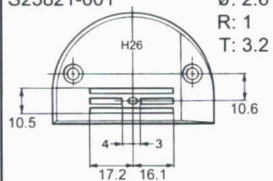
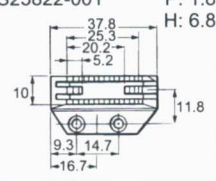

Gauge parts list (Heavy-weight materials : 4ROW)

4枚歯 / 4ROW

用途 Application	針板 Needle plate		送り歯 Feed dog	押え組 Presser foot assy
	記号 Mark			
厚物用 Heavy-weight Materials	H26	150792-101 ø: 2.6 R: 1 T: 3.2 	150793-001 P: 1.8 H: 6.8 	SA2837-101 150789-101 
	H26	S25821-001 ø: 2.6 R: 1 T: 3.2 	S25822-001 P: 1.8 H: 6.8 	

S-7200B-Ga9

Wa. 警告ラベル / Warning labels

警告ラベル / Warning labels	品名 / Name of parts	Size(mm)	Code
	<p>ラベル感電6ヶ国 Label, elec. shock 6 lang</p>	<p>50 X 118</p>	<p>J04115-001</p>
	<p>ラベル注意・和英 Label, caution Jpa / Eng</p>	<p>64 X 40</p>	<p>SA2040-001</p>
	<p>ラベル注意・中英 Label, caution Chn / Eng</p>	<p>64 X 40</p>	<p>SA2041-001</p>
	<p>アースマーク Label, grounding</p>	<p>φ 12</p>	<p>S37060-001</p>

S-7200B-Wa

索引 / INDEX

CODE	REF.NO	Page	CODE	REF.NO	Page	CODE	REF.NO	Page	CODE	REF.NO	Page
004301016	L - 24	32	025350132	C - 35	8	062500616	H - 6	24	100401022	K - 31	30
012060536	D - 14	12	026040236	L - 7	32		H - 45	24	100402004	J - 32	28
	D - 38	12		N - 12	38		H - 53	24	100463001	Q - 4	48
	D - 66	14	026050136	C - 4	8		J - 19	28	100463021	E - 3	18
	D - 77	14		P1 - 36	40		K - 28	30	100645003	L - 14	32
	F - 16	20	028040243	Q - 10	48		P4 - 17	46	100887001	Z - 43	56
	G - 17	22	028040245	P3 - 6	44		R - 11	50	102630001	B - 48	4
	L - 28	32	028050244	Z - 31	56		R - 14	50	102843004	L - 5	32
	L - 43	32	028050246	P1 - 35	40	062500816	D - 20	12	1044449001	A - 11	2
012061036	B - 47	4	028060243	Z - 55	58		D - 118	16		D - 63	14
012400436	B - 11	4	034422503	Q - 19	48		F - 6	20		J - 22	28
	B - 18	4	048030342	N - 22	38		H - 14	24	104450101	A - 7	2
	B - 25	4	048040142	L - 56	32		L - 61	32		A - 8	2
	B - 33	4	048040342	D - 55	12		L - 64	34		A - 10	2
	B - 41	4		K - 2	30		M - 3	36		H - 31	24
012500536	B - 46	4		K - 14	30		M - 10	36	104619022	E - 5	18
	B - 53	6		N - 16	38		N - 31	38	104821001	H - 19	24
	C - 18	8	048050142	T - 17	54		R - 12	50	105234003	L - 32	32
	D - 12	12	048050342	C - 26	8	062501216	A - 4	2	107415014	Z - 3	56
	D - 28	12	048060142	F - 14	20		A - 6	2		Sp5	63
	D - 35	12	048060342	B - 13	4		H - 51	24	107415022	Z - 3	56
	D - 44	12		B - 20	4		L - 58	32		Sp5	63
	D - 47	12		B - 27	4		P1 - 34	40	107780001	Z - 46	58
	D - 50	12		B - 35	4		T - 22	54	108549001	D - 3	12
	F - 11	20		B - 43	4	062501404	Z - 40	56	109714000	Z - 13	56
	F - 17	20		L - 41	32	062501416	D - 22	12	110087001	Q - 6	48
	J - 9	28	048080342	D - 18	12		D - 61	14	110087021	E - 8	18
	K - 8	30		T - 20	54		L - 22	32	110161004	M - 8	36
	K - 13	30	048100142	D - 119	16	062501816	J - 25	28	110367001	L - 40	32
	K - 34	30	048120142	B - 70	6	062670612	T - 24	54	110735002	N - 21	38
014300432	D - 82	14	048150142	D - 79	14	081004070	H - 7	24	111241001	Ga3	66
	D - 105	16	060300606	P4 - 12	46		H - 10	24	111508001	Ga3	66
014400632	P1 - 13	40		R - 8	50	081004870	H - 21	24	111856101	Ga1	64
014500632	P1 - 30	40	060350616	J - 24	28	081008070	H - 30	24		Ga2	65
014771032	L - 3	32	060400516	M - 5	36		H - 47	24		Ga5	68
017061216	T - 14	54		N - 14	38	081009070	K - 5	30		Ga6	69
017841606	Z - 52	58		N - 25	38	081015870	H - 43	24		Ga7	70
018400532	C - 22	8	060400816	M - 7	36	081022870	H - 36	24		Ga8	71
018501436	D - 33	12	060500616	J - 17	28	081025870	G - 8	22	111859301	Sp2	60
018501636	D - 29	12	062060816	P1 - 9	40	081029870	H - 54	26		Sp3	61
018761832	T - 10	54	062061016	F - 7	20	0A4261006	P1 - 18	40		Sp4	62
021060106	Z - 50	58	062061604	Z - 39	56	0A4300806	P1 - 16	40		Sp5	63
	Z - 54	58	062300616	D - 97	16		P1 - 28	40		Ga6	69
021060216	T - 15	54		N - 6	38	0A4401006	P1 - 26	40		Ga8	71
021060306	C - 42	10		N - 8	38	0A4401606	P1 - 25	40	111863001	H - 12	24
	H - 64	26		N - 9	38	0A4501206	H - 32	24	113280101	Ga1	64
	L - 53	32	062350616	D - 60	14	0A5300606	P1 - 22	40		Ga2	65
021400164	Q - 11	48	062400616	A - 14	2	100080004	D - 102	16		Ga3	66
021400206	P4 - 14	46		H - 48	24	100265031	Z - 3	56		Ga5	68
	R - 10	50		L - 8	32		Sp1	59		Ga6	69
021400306	L - 15	32		L - 19	32	100265034	Z - 3	56		Ga7	70
021500104	Z - 32	56		N - 11	38		Sp2	60		Ga8	71
	Z - 38	56	062400816	J - 15	28		Sp3	61	114294001	J - 37	28
021500316	D - 110	16		L - 57	32		Sp4	62	114561001	B - 65	6
025040173	P3 - 7	44		P4 - 13	46	100265042	Z - 3	56	114859001	Z - 56	58
025040232	C - 23	8		R - 9	50		Sp1	59	114967001	Q - 5	48
	L - 55	32	062400863	P3 - 5	44		Sp2	60	114967021	E - 7	18
025040233	Q - 9	48	062401006	Q - 8	48		Sp3	61	115188101	J - 29	28
025040332	H - 49	24	062401216	C - 38	8		Sp4	62	116922001	J - 31	28
025060136	K - 6	30		G - 21	22	100266101	Ga2	65	117132001	G - 28	22
	K - 15	30		K - 17	30	100267001	Ga3	66		Z - 5	56
	P1 - 10	40	062500616	B - 54	6	100328001	D - 6	12		Sp1	59
025100132	D - 17	12		C - 3	8	100399201	J - 28	28		Sp2	60

索引 / INDEX

CODE	REF.NO	Page	CODE	REF.NO	Page	CODE	REF.NO	Page	CODE	REF.NO	Page
117132001	Sp3	61	146231001	Ga2	65	153037201	Sp1	59	J03962001	P1 - 24	40
	Sp4	62	146232001	Ga2	65		Sp2	60	J03964001	P1 - 29	40
	Sp5	63	146233001	Ga1	64		Sp3	61	J03975001	P2 - 4	42
117442001	Ga2	65	146288001	N - 26	38		Sp4	62	J03976001	P2 - 5	42
117936001	A - 12	2	146290001	G - 27	22		Ga1	64	J03983001	P1 - 20	40
118837001	Z - 42	56		Z - 4	56		Ga2	65	J03984001	P1 - 21	40
119101001	Z - 51	58		Sp1	59		Ga5	68	J04086001	S - 1	52
122771051	B - 66	6		Sp2	60		Ga6	69	J04093001	S - 3	52
133643006	Z - 53	58		Sp3	61		Ga7	70	J04096001	S - 5	52
140004001	B - 9	4		Sp4	62		Ga8	71	J04097001	P3 - 8	44
	B - 16	4		Sp5	63	153132000	D - 24	12	J04098001	P3 - 8	44
	B - 23	4	146293001	H - 66	26	153138001	F - 13	20	J04099101	P3 - 14	44
	B - 31	4	147238001	Ga1	64	153147001	Ga1	64		P4 - 31	46
	B - 39	4	147239001	Ga1	64	153190001	Ga1	64	J04100001	P3 - 15	44
140407001	C - 8	8	147245101	Sp1	59	154125001	Z - 47	58	J04115001	P3 - 25	44
140553102	B - 55	6		Ga3	66	154567000	L - 2	32		Wa	73
140647101	N - 7	38	147322201	Ga3	66	154581001	L - 27	32	J04134001	S - 4	52
140957101	Ga1	64	147514001	C - 7	8	154593201	L - 35	32	J04149001	S - 6	52
	Ga2	65		Sp1	59	154594000	L - 36	32	J04167001	P3 - 10	44
	Ga5	68		Sp2	60	154595001	L - 38	32	J04168001	P3 - 22	44
	Ga6	69		Sp3	61	154596000	L - 39	32	J04169001	P3 - 21	44
	Ga7	70		Sp4	62	154607101	M - 6	36	J04179001	P4 - 21	46
	Ga8	71		Sp5	63	154729001	F - 2	20	J04186001	P4 - 23	46
141096001	Ga2	65	147531101	Ga1	64	154730001	F - 3	20	J04189001	P4 - 25	46
141728001	C - 7	8		Ga2	65	154731000	F - 4	20	J04195001	P2 - 6	42
	Sp1	59		Ga5	68	154742001	Ga3	66	J04210001	P3 - 23	44
	Sp2	60		Ga6	69	155676001	Ga7	70	J04215001	P4 - 24	46
	Sp3	61		Ga7	70	156114001	Ga7	70	J04243001	P3 - 24	44
	Sp4	62		Ga8	71	156115001	Ga6	69	J04249001	P4 - 26	46
	Sp5	63	148537101	L - 21	32	156116001	Ga6	69	J04251001	S - 8	52
142002001	Z - 44	58	149097000	N - 29	38	156243021	D - 78	14	J04255001	S - 9	52
142026003	Q - 2	48	149578000	H - 57	26	156958021	D - 27	12	J04273001	P2 - 7	42
142027001	Q - 3	48	149799000	Q - 18	48		D - 53	12	J04296001	P1 - 27	40
142374100	D - 9	12	150172003	Z - 25	56	158722001	D - 86	14	J04314001	P4 - 27	46
142443001	Z - 41	56	150174000	Z - 22	56	159324001	G - 20	22	J04392001	P1 - 33	40
142721001	Z - 45	58		Z - 26	56		Sp1	59	J04393001	P3 - 1	44
142990001	Z - 36	56	150179002	Z - 30	56		Sp2	60	J04438001	P3 - 2	44
143548000	Q - 15	48	150182000	Z - 18	56		Sp3	61	J04440001	P3 - 3	44
143549000	Q - 14	48	150183000	Z - 35	56		Sp4	62	J04442001	P1 - 32	40
143711101	Ga1	64	150206000	Z - 28	56		Sp5	63	J04468001	P3 - 16	44
	Ga2	65	150206002	Z - 20	56	159805001	J - 34	28	J04469001	S - 2	52
	Ga5	68	150207001	Z - 27	56	159859201	Ga5	68	J04470001	S - 7	52
	Ga6	69	150789101	C - 9	8	180018151	B - 64	6	J04487001	P1 - 19	40
	Ga7	70		Sp2	60	183388001	G - 23	22	J04593001	P3 - 9	44
	Ga8	71		Sp3	61	183389001	G - 24	22	J80081040	P4 - 28	46
143882001	Z - 9	56		Sp4	62	183390001	G - 25	22	J800810E0	P4 - 28	46
143910009	Z - 10	56		Ga9	72	233268002	P4 - 22	46	J80380040	P4 - 29	46
144226001	Z - 15	56	150792001	Sp2	60	BMP2060-0000000-OG40			J803800E0	P4 - 29	46
144504001	J - 5	28		Sp5	63		P2 - 1	42	J80630001	P4 - 30	46
144875001	H - 15	24	150792101	Sp3	61	BMP2060-0000000-CG40			J806300E1	P4 - 30	46
145157101	C - 9	8		Sp4	62		P2 - 1	42	J80964201	P3 - 19	44
	Sp1	59		Ga9	72	BMP2060-0000000-EG40			J80965001	P3 - 20	44
	Ga3	66	150793001	D - 90	14		P2 - 1	42	J80966101	P3 - 20	44
145446001	J - 33	28		Sp2	60	J00494001	P3 - 12	44	J80967001	P3 - 17	44
145446002	K - 30	30		Sp3	61	J01411001	P3 - 11	44	J80968001	P3 - 17	44
145737001	H - 9	24		Sp4	62	J03733001	P3 - 4	44	J80970001	P3 - 18	44
145971101	Sp1	59		Sp5	63	J03739001	P3 - 13	44	J80973001	P2 - 2	42
	Ga2	65		Ga9	72	J03940001	P1 - 11	40	J80974001	P2 - 3	42
146039021	E - 2	18	151267001	B - 63	6	J03955001	P1 - 12	40	J80975001	P4 - 20	46
146046000	Q - 16	48	151308102	D - 11	12	J03956001	P1 - 14	40	S01005000	Z - 23	56
146050001	Ga1	64		D - 43	12	J03957001	P1 - 15	40	S01107101	Ga5	68
146194000	Q - 17	48	151594001	B - 62	6	J03958001	P1 - 17	40	S01419000	J - 11	28
146231001	Ga1	64	153037201	C - 9	8	J03961001	P1 - 23	40	S01904001	Ga1	64

索引 / INDEX

CODE	REF.NO	Page	CODE	REF.NO	Page	CODE	REF.NO	Page	CODE	REF.NO	Page
S01904001	Ga2	65	S13561101	Sp3	61	S29649001	Ga1	64	S52936001	Sp1	59
	Ga5	68		Sp4	62	S30103001	Ga8	71		Sp2	60
	Ga6	69		Sp5	63	S31006001	C - 31	8		Sp3	61
	Ga7	70	S13684001	Ga5	68	S31032001	J - 36	28		Sp4	62
	Ga8	71		Ga6	69		K - 32	30		Sp5	63
S02602001	G - 20	22		Ga7	70	S31885001	E - 9	18	S55655201	J - 27	28
	Sp1	59		Ga8	71	S31899251	D - 41	12	SA1105001	A - 5	2
	Sp2	60	S16335001	D - 51	12	S31910001	Ga6	69	SA1106001	A - 1	2
	Sp3	61	S16337001	D - 52	12	S31938001	Q - 12	48	SA1107001	A - 2	2
	Sp4	62	S16625050	T - 7	54	S31939001	Q - 13	48	SA1120001	B - 5	4
	Sp5	63	S16629151	T - 9	54	S32263001	A - 9	2	SA1133001	Sp1	59
S02620201	J - 28	28	S16630051	T - 16	54	S32907050	P4 - 9	46		Sp2	60
S02637001	L - 4	32	S16643009	T - 23	54		R - 7	50		Sp3	61
S02643001	L - 6	32	S17774001	Z - 1	56	S34281000	P4 - 4	46		Sp4	62
S02645001	L - 20	32	S20356001	T - 19	54	S34352101	D - 70	14	SA1134001	Sp5	63
S02646001	L - 65	34	S23418002	K - 19	30	S34756021	E - 6	18	SA1135001	Sp1	59
S02647021	L - 25	32	S23651001	B - 2	4	S35775010	Sp1	59		Sp2	60
S02648001	L - 26	32		B - 6	4		Sp2	60		Sp3	61
S02742001	D - 89	14		B - 57	6		Sp3	61		Sp4	62
	Sp1	59		B - 74	6		Sp4	62	SA1136001	Sp5	63
	Ga1	64		B - 76	6	S35776101	Ga4	67	SA1137001	Sp1	59
	Ga2	65		B - 79	6	S35776201	Sp1	59		Sp2	60
S02743001	D - 89	14		B - 81	6	S35777101	C - 9	8		Sp3	61
	Sp1	59		D - 68	14		Sp1	59		Sp4	62
	Ga3	66		D - 81	14		Sp2	60		Sp5	63
S02744001	Ga5	68		D - 112	16		Sp3	61	SA1138101	B - 51	6
S02747101	Z - 24	56		G - 12	22		Sp4	62	SA1139101	B - 52	6
S02748001	D - 91	14		G - 14	22		Ga4	67	SA1140001	B - 56	6
	Sp1	59		G - 19	22	S35820021	E - 4	18	SA1143001	B - 67	6
	Ga4	67		L - 33	32	S35821021	E - 1	18	SA1144001	B - 68	6
	Ga5	68	S25235001	B - 3	4	S36893050	L - 47	32	SA1145001	B - 69	6
S02763602	Z - 16	56	S25236001	B - 4	4	S37060001	P3 - 26	44	SA1150001	B - 78	6
S02999201	Ga5	68		D - 57	14		Wa	73	SA1166001	B - 73	6
S03000201	Ga5	68		D - 95	16	S37061010	Z - 3	56	SA1171001	C - 1	8
S03245001	G - 22	22	S25279101	N - 18	38		Sp5	63	SA1173001	C - 1	8
S03246001	G - 26	22	S25321001	D - 59	14	S38687000	L - 59	32	SA1174001	C - 5	8
S03677001	N - 27	38	S25339201	D - 96	16	S38712001	B - 59	6	SA1175001	C - 36	8
S03882201	Ga5	68	S25344001	H - 62	26	S38713100	B - 60	6	SA1176001	C - 12	8
S03883201	Sp2	60	S25380401	H - 17	24	S38760001	Ga4	67	SA1177001	C - 13	8
	Sp3	61	S25382001	H - 5	24	S38769000	H - 8	24	SA1178001	C - 14	8
	Sp4	62		H - 22	24	S38803051	T - 4	54	SA1179001	C - 15	8
	Sp5	63		H - 25	24	S38804050	T - 5	54		C - 27	8
	Ga5	68	S25401100	B - 71	6	S39051001	C - 32	8		C - 30	8
S03884301	Ga6	69	S25426101	L - 11	32	S39830101	D - 107	16		H - 68	26
S04159000	P4 - 15	46	S25427101	D - 113	16	S40765001	Z - 49	58	SA1181001	C - 17	8
S04630000	H - 11	24	S25434000	L - 37	32	S40938001	J - 30	28	SA1182001	C - 19	8
S04632101	J - 29	28	S25449201	N - 5	38	S41205001	N - 4	38	SA1183001	C - 20	8
S06055009	Z - 6	56	S25454001	N - 17	38	S41206001	N - 3	38	SA1184001	C - 21	8
S07027001	Q - 7	48	S25456001	N - 23	38	S41207000	N - 28	38	SA1186001	C - 24	8
S07350001	C - 25	8		N - 30	38	S42893001	C - 7	8	SA1189101	C - 41	10
S07649001	Ga1	64	S25457101	Q - 1	48	S45050001	A - 16	2	SA1190001	C - 29	8
	Ga2	65	S25469100	D - 16	12	S45563001	J - 3	28	SA1193001	C - 40	10
S07783001	Z - 48	58	S25475101	H - 63	26	S45837001	C - 33	8	SA1206001	D - 15	12
S09621151	A - 13	2	S25789000	K - 9	30	S47487001	H - 37	24	SA1207001	D - 19	12
S09634000	Z - 7	56	S25821001	Ga9	72	S47508101	D - 106	16	SA1209001	D - 23	12
S11222001	Ga2	65	S25822001	Ga8	71	S47509001	H - 39	24	SA1210001	D - 25	12
S12441001	J - 35	28		Ga9	72	S50098101	D - 5	12	SA1211001	D - 26	12
	K - 33	30	S29644001	Ga3	66	S51272100	H - 42	24	SA1214101	D - 32	12
S12915001	D - 58	14	S29645001	Ga2	65	S51282101	Z - 19	56	SA1217101	D - 40	12
S13385001	C - 11	8	S29646001	Ga1	64	S51283001	Z - 17	56	SA1218001	D - 42	12
S13561101	C - 7	8	S29647101	Ga6	69	S51815001	H - 26	24	SA1223001	D - 48	12
	Sp1	59		Ga8	71		H - 35	24	SA1225001	D - 54	12
	Sp2	60	S29648101	Ga6	69	S52764001	H - 18	24	SA1226101	D - 62	14

索引 / INDEX

CODE	REF.NO	Page	CODE	REF.NO	Page	CODE	REF.NO	Page	CODE	REF.NO	Page
SA1227101	D - 64	14	SA1371201	M - 1	36	SA2170001	A - 15	2	SA2433101	Sp5	63
SA1228001	D - 65	14	SA1372001	M - 2	36	SA2171001	M - 9	36		Ga4	67
SA1229101	D - 67	14	SA1373001	M - 4	36	SA2177001	T - 6	54	SA2689101	R - 18	50
	J - 12	28	SA1374301	N - 1	38	SA2190001	K - 24	30	SA2778201	C - 34	8
SA1230001	D - 71	14	SA1376001	N - 10	38	SA2194201	B - 50	4	SA2779001	H - 40	24
SA1231001	D - 72	14	SA1377001	N - 20	38	SA2250001	B - 58	6	SA2836101	C - 10	8
SA1233101	D - 76	14	SA1378201	N - 24	38	SA2251001	B - 75	6		Sp5	63
SA1234001	D - 80	14	SA1388101	P4 - 18	46	SA2252001	B - 80	6		Ga1	64
SA1237001	D - 75	14		R - 15	50	SA2254101	B - 82	6		Ga2	65
SA1238401	D - 83	14		R - 17	50	SA2258001	L - 31	32		Ga5	68
SA1239201	D - 84	14	SA1390001	R - 6	50	SA2270001	P4 - 3	46		Ga6	69
SA1242001	D - 87	14	SA1391601	L - 44	32		R - 2	50		Ga7	70
	D - 104	16	SA1392001	L - 45	32	SA2286001	F - 15	20		Ga8	71
SA1245101	D - 93	16	SA1393001	L - 46	32	SA2287001	N - 19	38	SA2837101	C - 10	8
SA1247001	D - 94	16	SA1394101	L - 63	34	SA2293101	D - 117	16		Sp5	63
SA1250101	D - 100	16		R - 16	50	SA2294101	D - 115	16		Ga9	72
SA1251001	D - 101	16	SA1396001	N - 2	38	SA2295201	D - 111	16	SA2838101	Ga3	66
SA1253101	D - 98	16	SA1397001	T - 1	54	SA2296001	T - 13	54	SA2839101	Ga1	64
SA1254001	D - 99	16	SA1399201	F - 1	20	SA2343001	H - 2	24		Ga2	65
SA1258001	F - 5	20	SA1656011	Z - 2	56	SA2345001	D - 90	14		Ga3	66
SA1261001	D - 56	14	SA1656014	Z - 2	56		Sp2	60		Ga5	68
SA1263001	D - 56	14	SA1656022	Z - 2	56		Sp3	61		Ga6	69
SA1269001	D - 39	12	SA1658010	Z - 2	56		Sp4	62		Ga7	70
SA1273001	G - 10	22	SA1660010	Z - 2	56		Sp5	63		Ga8	71
SA1284001	G - 15	22	SA1752014	Z - 2	56		Ga6	69	SA2840101	Ga1	64
SA1285001	G - 16	22	SA1752022	Z - 2	56		Ga8	71		Ga2	65
SA1286001	G - 18	22	SA1941001	T - 2	54	SA2346001	D - 92	14		Ga5	68
SA1291001	J - 21	28	SA1942001	T - 3	54		Sp2	60		Ga6	69
SA1292001	H - 1	24	SA1950001	T - 12	54		Sp3	61		Ga7	70
SA1295001	H - 13	24	SA1961101	J - 20	28		Sp4	62		Ga8	71
SA1300001	H - 27	24	SA1962001	Z - 11	56		Sp5	63	SA2841101	Ga1	64
SA1303001	H - 29	24	SA1963001	Z - 12	56		Ga5	68		Ga2	65
	H - 46	24	SA1967001	N - 15	38		Ga6	69		Ga5	68
SA1304001	H - 3	24	SA1969001	Z - 8	56		Ga8	71		Ga6	69
SA1305001	H - 4	24	SA1971101	K - 1	30	SA2347001	D - 109	16		Ga7	70
SA1306001	H - 33	24	SA1975001	K - 3	30	SA2348001	C - 7	8		Ga8	71
SA1307001	H - 34	24	SA1978001	K - 4	30	SA2351101	J - 1	28	SA2842101	Ga1	64
SA1309001	H - 38	24	SA1980001	K - 7	30	SA2352101	J - 1	28		Ga2	65
SA1313101	H - 44	24	SA1981101	K - 10	30	SA2354001	P1 - 31	40		Ga5	68
SA1314001	H - 50	24	SA1982101	K - 11	30	SA2356101	J - 6	28		Ga6	69
SA1316001	H - 52	24	SA1983001	K - 12	30	SA2358101	J - 8	28		Ga7	70
SA1317001	B - 72	6	SA1984001	K - 16	30	SA2362001	J - 2	28		Ga8	71
SA1321401	H - 55	26	SA1985001	K - 18	30	SA2363001	J - 4	28	SA2844101	F - 9	20
SA1322301	H - 56	26	SA1988001	K - 20	30	SA2377001	D - 69	14	SA2848001	F - 10	20
SA1323001	H - 58	26	SA1989001	K - 21	30	SA2378001	B - 77	6	SA2849001	D - 10	12
SA1324001	H - 59	26	SA1990101	K - 22	30	SA2383001	L - 34	32	SA2850101	D - 31	12
SA1325001	H - 60	26	SA1991001	K - 23	30	SA2386001	P4 - 8	46	SA2851001	D - 34	12
SA1326101	H - 61	26	SA1992101	K - 25	30	SA2387001	P4 - 10	46	SA2852001	F - 8	20
SA1327101	H - 67	26	SA1994101	K - 29	30	SA2388101	P4 - 2	46	SA2854001	D - 30	12
SA1332001	T - 18	54	SA1998001	L - 60	32	SA2389001	P4 - 7	46	SA2856101	Ga1	64
SA1335001	T - 8	54	SA2040001	A - 17	2	SA2390101	P4 - 19	46		Ga2	65
SA1336001	T - 11	54		Wa	73	SA2401001	D - 103	16		Ga5	68
SA1338001	T - 21	54	SA2041001	A - 17	2	SA2404001	B - 61	6		Ga6	69
SA1342001	J - 18	28		Wa	73	SA2405001	P4 - 11	46		Ga7	70
SA1343001	J - 13	28	SA2097101	L - 51	32	SA2406001	P4 - 16	46		Ga8	71
SA1345001	J - 16	28	SA2161001	B - 12	4	SA2407001	P4 - 1	46	SA2868001	L - 62	32
SA1359001	J - 10	28		B - 19	4	SA2417001	J - 14	28		P1 - 8	40
	K - 26	30		B - 26	4	SA2422001	B - 10	4	SA2875001	G - 29	22
SA1360101	K - 27	30		B - 34	4		B - 17	4	SA2992001	F - 12	20
SA1362101	L - 29	32		B - 42	4		B - 24	4	SA3025001	P1 - 38	40
SA1363001	L - 30	32	SA2162001	D - 73	14		B - 32	4	SA3114001	D - 116	16
SA1366001	L - 42	32	SA2165001	C - 28	8		B - 40	4	SA3152001	D - 114	16
SA1367201	L - 48	32		T - 25	54	SA2433101	C - 10	8	SA3158101	H - 24	24

索引 / INDEX

CODE	REF.NO	Page	CODE	REF.NO	Page	CODE	REF.NO	Page	CODE	REF.NO	Page
SA3508001	H - 65	26	SA7295001	R - 3	50						
SA3980001	C - 16	8	SA7297101	Z - 14	56						
SA4098001	P4 - 5	46	SA7320001	G - 9	22						
	R - 4	50	SA7321001	D - 21	12						
SA4099001	P4 - 6	46	SA7323201	D - 45	12						
	R - 5	50	SA7324201	D - 46	12						
SA4211001	P1 - 37	40	SA7325001	P1 - 2	40						
SA4259001	A - 3	2	SA7330001	D - 85	14						
SA4494001	D - 2	12	SA7341101	L - 18	32						
SA4552001	H - 41	24	SA7345101	H - 23	24						
SA5329001	L - 13	32	SA7422001	D - 108	16						
SA5730101	P1 - 4	40	SA7525001	G - 4	22						
SA5731001	P1 - 6	40	SA7552001	L - 1	32						
SA5732001	P1 - 5	40	SA7554001	G - 13	22						
SA6167001	J - 7	28	SA7577001	L - 12	32						
SA6606001	Z - 29	56	SA7607001	C - 6	8						
SA6607001	Z - 33	56	SA7625001	B - 8	4						
	Z - 34	56		B - 22	4						
SA6609001	Z - 37	56		B - 38	4						
SA6629001	Z - 21	56	SA7626001	B - 15	4						
SA7148001	G - 3	22	SA7627001	B - 30	4						
SA7209101	B - 1	4	SA7635001	D - 13	12						
SA7212101	B - 7	4	SA7636001	H - 16	24						
SA7222101	B - 14	4	SA7654001	B - 28	4						
SA7227101	B - 21	4		B - 36	4						
SA7234101	B - 29	4		B - 44	4						
SA7238101	B - 37	4	SA7686002	Sp1	59						
SA7239101	B - 45	4		Sp2	60						
SA7240001	Sp5	63		Sp3	61						
SA7241001	Sp1	59		Sp4	62						
	Sp2	60		Sp5	63						
	Sp3	61	SA7687001	Sp1	59						
	Sp4	62		Sp2	60						
SA7242001	C - 2	8		Sp3	61						
SA7243001	D - 1	12		Sp4	62						
SA7246001	D - 4	12		Sp5	63						
SA7249101	D - 7	12	SA7688001	Sp1	59						
SA7250101	D - 8	12		Sp2	60						
SA7252001	D - 36	12		Sp3	61						
SA7253001	D - 37	12		Sp4	62						
SA7254001	D - 49	12		Sp5	63						
SA7255001	D - 74	14	SA7693001	G - 7	22						
SA7257001	D - 88	14	SA7879001	G - 6	22						
SA7261101	G - 1	22	SA7898201	L - 49	32						
SA7262001	G - 2	22	SA7899001	L - 50	32						
SA7263301	G - 5	22	SA7900001	L - 52	32						
SA7265101	H - 20	24	SA8002001	N - 13	38						
SA7266001	G - 11	22	SA8004001	C - 39	10						
SA7269001	H - 28	24	SA8005001	C - 37	8						
SA7271001	J - 23	28	SA8008001	R - 13	50						
SA7272001	J - 26	28									
SA7273001	J - 27	28									
SA7275001	J - 29	28									
SA7282101	L - 9	32									
SA7283001	L - 10	32									
SA7284101	L - 16	32									
SA7285001	L - 17	32									
SA7287001	L - 23	32									
SA7288001	L - 54	32									
SA7291101	P1 - 1	40									
SA7292101	P1 - 3	40									
SA7293001	P1 - 7	40									
SA7294001	R - 1	50									

brother®

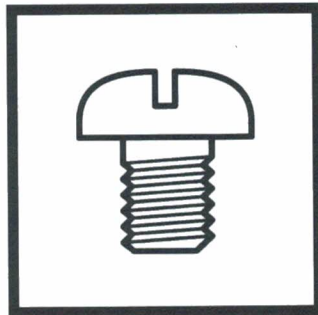

パーツブック
PARTS BOOK

ブラザー工業株式会社 <http://www.brother.co.jp/>

〒467-8561 名古屋市瑞穂区苗代町 15 番 1 号 TEL : 0120-33-2392

BROTHER INDUSTRIES, LTD. <http://www.brother.com/>

15-1, Naeshiro-cho, Mizuho-ku, Nagoya 467-8561, Japan. Phone : 81-52-824-2177

©2006 Brother Industries, Ltd. All Rights Reserved.

S-7200B
SA7309-001.J/E
2006.04.B (1)