

BAS-300G-484 Thread Trimming Cylinder Sensor Adjustment

1. Enter input checking mode by holding Δ key and power turn on.
2. Select input checking number 24 by pressing Δ or ∇ key.
3. Press solenoid valve (5) activate button and find sensor position signal change "OFF" to "ON".
4. Please refer to the following note.

2-8. Input checking method

Use this to check for any malfunctions of the operation panel keys, circuit boards or sensors, and for checking for broken cords and for adjusting sensor positions.

You can check whether the CPU is correctly reading the signals from keys and sensors.

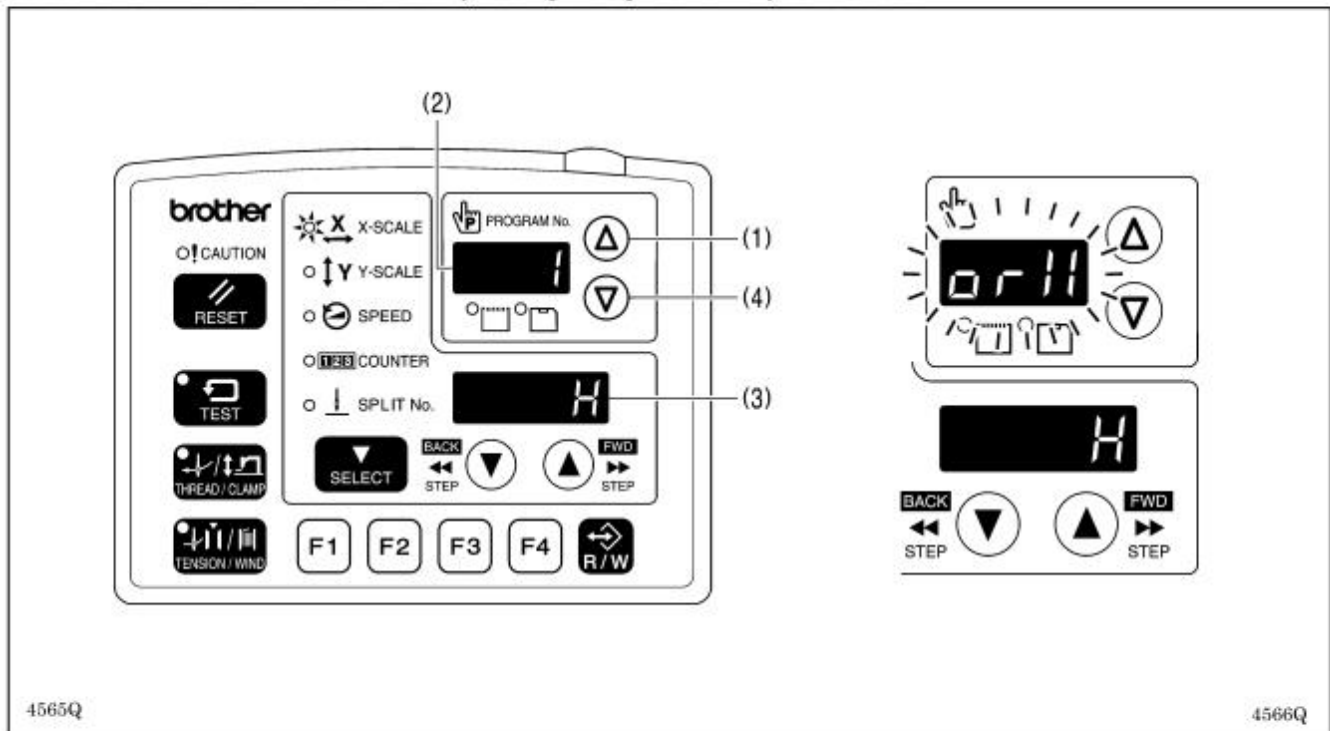

1. While pressing the Δ key (1), turn on the power switch.
* Keep pressing the Δ key (1) until the model name is displayed and the buzzer beeps once.
The check code will be displayed in the PROGRAM No. display (2), and the input status will be displayed in the menu display (3).
2. Press the Δ key (1) or ∇ key (4) to select the desired check code.
If no operations are carried out for 5 seconds after a check code has been selected, the check code and the abbreviated input name will flash alternately in the PROGRAM No. display (2).
3. Refer to the input check list for key and sensor responses.
4. To return to normal operation, turn off the power switch and then turn it back on again.

<Input check list>

PROGRAM No. display		Menu display	Check item and checking method
Check code	Name	Input status	
[1]	[orX]	[H] / [L]	X-axis motor home position sensor signal Move the feed mechanism by hand in the X direction.
[2]	[EnX]	[-999] - [999]	X-axis motor encoder counter value Move the feed mechanism by hand in the X direction.
[3]	[orY]	[H] / [L]	Y-axis motor home position sensor signal Move the feed mechanism by hand in the Y direction.
[4]	[EnY]	[-999] - [999]	Y-axis motor encoder counter value Move the feed mechanism by hand in the Y direction.
[5]	[orP]	[H] / [L]	Work clamp motor home position sensor signal Raise the work clamp by hand.
[6]	[EnP]	[-999] - [999]	Work clamp motor encoder counter value Raise the work clamp by hand.
[7]	[Enn]	[0] - [180]	Upper shaft 180 degree rotation signal Turn the pulley by hand.

PROGRAM No. display		Menu display	Check item and checking method
Check code	Name	Input status	
[8]	[UP]	[on] / [oFF]	Needle up signal Turn the pulley by hand.
[9]	[dn]	[on] / [oFF]	Needle drop signal Turn the pulley by hand.
[10]	[voL]	[0] – [300]	Power supply voltage Displayed as %
[11]	[PnL]	[*] / [oFF]	Operation panel input check While a key is being pressed, the name of the key will be displayed.
/		*ON display	Key name
		[rESt]	RESET key
		[tESt]	TEST key
		[tHrE]	THREAD/CLAMP key
		[tEn]	TENSION/WIND key
		[SELE]	SELECT key
		[UP-M]	▲ key
		[dn-M]	▼ key
		[F1]	Function key F1
		[F2]	Function key F2
		[F3]	Function key F3
		[F4]	Function key F4
		[CF]	R/W key
[12]	[FtA]	[0] – [255]	Foot switch analog value (Single pedal specifications) Depress the foot switch.
[13]	[CL1]	[on] / [oFF]	Work clamp 1st step (2 pedal specifications) Depress the foot switch to the 1st step.
[14]	[CL2]	[on] / [oFF]	Work clamp 2nd step (2 pedal specifications) Depress the foot switch to the 2nd step.
[15]	[Stt]	[on] / [oFF]	Start switch (2 pedal specifications) Depress the foot switch to the 2nd step.
[16]	[EMC]	[– – on] [on – –] [– – – –]	STOP switch Press the STOP switch.
[17]	[HEd]	[on] / [oFF]	Machine head switch Tilt back the machine head.
[18]	[EXE]	[on] / [oFF]	External input error detection (IN13)
[19]	[CAH]	[on] / [oFF]	Thread nipper home position sensor (IN14) (*1) Press the ▲ key to move the thread nipper in the home position direction. Press the ▼ key to move the thread nipper in the retract direction.
[20]	[rEL]	[on] / [oFF]	Thread nipper retract sensor (IN15) (*1) Press the ▲ key to move the thread nipper in the home position direction. Press the ▼ key to move the thread nipper in the retract direction.
[21]	[in1]	[on] / [oFF]	Option input (IN1)
[22]	[in2]	[on] / [oFF]	Option input (IN2)
[23]	[in3]	[on] / [oFF]	Option input (IN3)
[24]	[in4]	[on] / [oFF]	Option input (IN4)
[25]	[in5]	[on] / [oFF]	Option input (IN5)
[26]	[rot]	[on] / [oFF]	Option input (IN11)
[27]	[Fib]	[on] / [oFF]	Fiber-type thread breakage detection [Option compatibility]

For Thread Trimming
Solenoid Valve Sensor Signal

*1 Not used for the BAS-311G and BAS-326G.

- Location of solenoid valve will describe the next page.

For Activation of solenoid valve

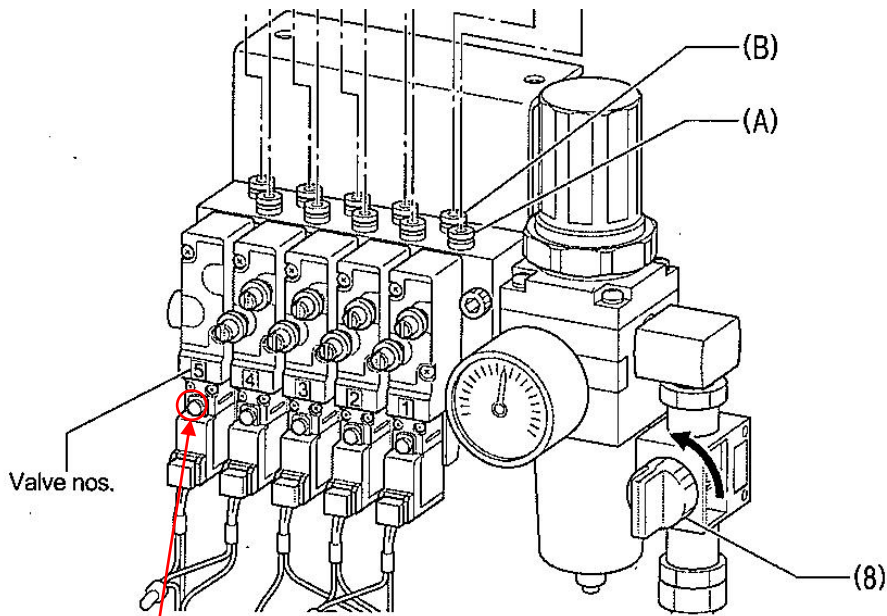

By pressing this button air cylinder will be activated.



If signal won't change to "ON", check black cord (#11) of thread trimming solenoid valve harness is security inserted connector.

