

Electronic Direct Drive Lockstitch Button Holer

HE-800B

Less sewing troubles with a new hook, enhancing the sewing finishes.
Comfortable sewing and high energy saving have been realized with
a new original motor and control box developed in-house.

Beautiful sewing finishes
Operator-friendly
Environment-conscious
High Productivity

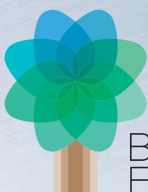

Brother
Earth

Upgraded electronic button hole - It enhances the sewing quality with a new hook, preventing thread breakages and insufficient thread tightening Equipped the direct drive system, it provides comfortable sewing and high energy saving

Electronic Direct Drive
Lockstitch Button Holer

HE-800B

Perfect sewing finishes

Less sewing troubles with the newly designed hook

Equipped with the new hook, it prevents sewing troubles such as thread breakages and insufficient thread tightening.

It realizes stitches even if with low tension, providing a quality finish for purl stitch and whip stitch.

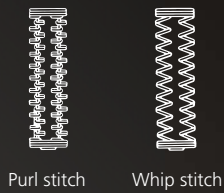

Purl stitch Whip stitch

Beautiful sewing finishes even fine patterns

Minimum resolution of needle zigzag is fined to 0.05mm, preventing the fuzz caused by the cutter. It's capable of various fine sewing patterns as well.

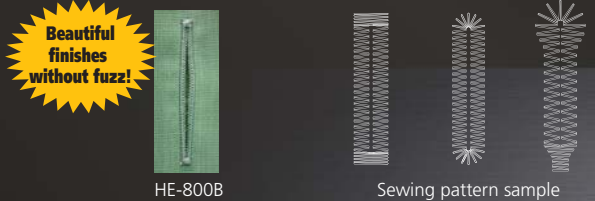

Beautiful finishes without fuzz!

HE-800B

Sewing pattern sample

Easy for difficult-to-sew materials with underlay

With underlay functionality, it is effective for stretch materials to prevent them from stretching.



With Underlay Without Underlay

Under lay patterns

Rectangle

- Effective for preventing material from stretching.
- Keep flexibility of the stitch, reinforcing the buttonhole.

Saw shape

- This is useful for preventing dimples from forming during bar tacking.
- It is also useful for stretching the buttonholes to stop the seam from unraveling, which can often happen with materials with coarse weaves.

Sew together

- Used for resewing.
- The pile of fluffy fabrics is pressed down before sewing, so that the buttonhole finish looks more attractive.

Zigzag

- This is effective in preventing seams from unraveling in materials.
- * Available after saw shape underlays or rectangle underlays have been set.



Environment-conscious

The industry's top-class energy savings

High energy saving's has been realized by direct drive system, which keeps the power transmission loss of the motor to a minimum with an original motor developed by Brother. The power consumption of the machine is approximately 50% less than that of the previous model HE-800A. This is industry's top-class energy saving and environment-conscious machine.

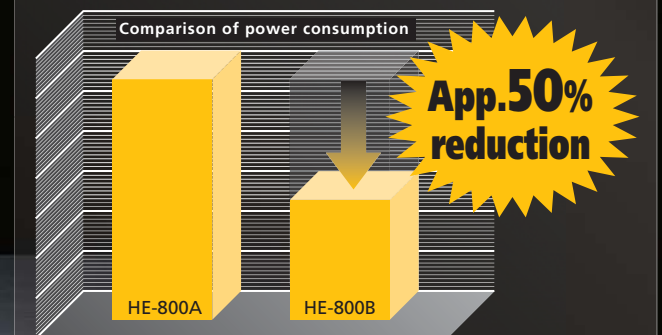

Operator-friendly

Easy and operator-intuitive operation panel

The HE-800B is equipped with a liquid crystal display (LCD) and indicates display items with icons and letters. Setting and check of sewing patterns and change of sewing modes are easy to understand and carry out. It supports multilinguality as display language.



SD card slot

SD card slot is equipped as standard. Sewing pattern and environmental setting can easily be copied and moved to other sewing machines.

Shortcut key

Frequently-used settings such as sewing width and size of sewing patterns can be set quickly.

Production counter

It can count how many articles are sewn up to 9,999,999.

Lower thread counter

You can easily see the amount of lower thread available.



Mode key

Useful mode such as threading mode and thread winding mode can be set with one-touch key operation.

High productivity

High productivity has been realized with direct drive system which minimizes the power transmission loss of the motor.

Comfortable sewing with less noise

V-belt sound has been deleted by direct drive system. Less noise and comfortable environment help reduce stress and fatigue of operators who have to sit in front of the machines for long hours.

Easy positioning

The presser foot lifter is driven by a pulse motor, so that the height can be adjusted as desired (standard function). This makes insertion and removal of the material easier and reduces working fatigue.



New pulley cover

Pulley cover is newly added considering the safety and efficiency of maintenance.



HE-800B-□



Application	
2	Woven articles such as shirts, blouses, work clothes and ladies' attire
3	Knitted article such as underwear, sweaters, cardigans and jerseys

Max. sewing speed	4,000 sti/min	
Zigzag mechanism	Pulse motor	
Feed mechanism	Pulse motor	
Work clamp lifter mechanism	Pulse motor	
Height of work clamp	Max. 13mm (adjustable)	
Cutter drive method	Double position solenoid	
Lower thread holding device	Standard equipment	
Bobbin presser	Standard equipment	
Standard pattern shapes	21 types	
No. of standard sewing pattern	50	
Max. No. of stitch/program	999 stitches (overall cycle program stitch no. 3,000 stitches)	
Needle	-2	-3
	Schmetz 134 Nm90	Schmetz 134 Nm75
Data storage method	SD card (No guarantees of operation can be given for any media.)	
Power supply	Single-phase 100V / 220V, 3-phase 220V / 380V / 400V (For single-phase 100V and 3-phase 380V / 400V, the trans box is required.)	

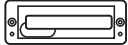

Gauge parts list

Button hole size	Work Clamp Assy with Finger Guard			Sewing area	
		Finger guard	Work clamp		
	Parts code	Parts code	Parts code		
-2*1	16mm	S37101-302	159079-100	159761-002	4 x 20
	25mm	*S37100-402	159080-100	159762-002	4 x 32
	25mmW*2	S55347-302	159080-100	S55345-002	6 x 32
	32mm	S37109-302	159081-100	159763-002	6 x 40
-3	16mm	S37103-301	159079-100	145136-001	4 x 20
	25mm	*S37102-401	159080-100	144630-001	4 x 32
	25mmW*2	S55350-301	159080-100	S55348-001	5.4 x 32
	32mm	S37110-301	159081-100	144632-001	5.4 x 40

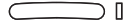
*Standard shipment *1 All work clamp for -2 is with rubber. *2 W is wide bar tack width work clamp.

For Flat Cutter				
Needle hole size				
	Needle plate for cutter	Needle plate for flat cutter	Plastic plate	
	Parts code	Parts code	Parts code	
-2	1.2mmS	S50663-001	S50321-001	151843-001
	1.4mmS	*S50664-001	—	—
	1.6mmS	S50665-001	—	—
-3	1.2mm	*S51248-101	S50322-101	156612-001
	1.4mm	S51249-101	—	—
	1.6mm	S51250-101	—	—

*Standard shipment

Cutter size		
	Cutter	Flat Cutter
	Parts code	Parts code
6.4mm (1/4)	S51117-001	—
9.5mm (3/8)	S51290-001	S01271-001
11.1mm (7/16)	S51351-001	S01272-001
12.7mm (1/2)	*S51352-001	S01273-001
14.3mm (9/16)	S51353-001	S03280-001
15.9mm (5/8)	S51354-001	S01274-001
17.5mm (11/16)	S51355-001	—
19.1mm (3/4)	S51356-001	S01275-001
20.6mm (13/16)	S25642-001	—
22.2mm (7/8)	S51357-001	S01276-001
25.4mm (1)	S51358-001	S35630-001
29mm	S51359-001	—
32mm	S51360-001	—

*Standard shipped gauge (common for -2 and -3)

RoHS Compliant

HE-800B is compliant with the RoHS Directive (the restriction of the use of certain hazardous substances in electrical and electronic equipment) which came into.

Product specifications are subject to change for improvement without notice.
Please read instruction manual before using the machine for safety operation.

brother

BROTHER INDUSTRIES, LTD.

1-5, Kitajizoyama, Noda-cho, Kariya-shi, Aichi 448-0803, Japan.
Phone: 81-566-95-0088 Fax: 81-566-25-3721 <http://www.brother.com/>

CHINA	BROTHER MACHINERY SHANGHAI LTD. http://www.brother-cn.net/	+86-21-3135-3355
HONG KONG	BROTHER INTERNATIONAL (HK) LTD. http://www.brother.com.hk/	+852-3589-9040
ASIA	BROTHER INTERNATIONAL SINGAPORE PTE LTD. http://www.brother.com.sg/	+65-6536-8891
EUROPE AFRICA, MIDDLE EAST	BROTHER INTERNATIONALE INDUSTRIEMASCHINEN G. m. b. H. http://www.brother-ism.com/BROTHER INTERNATIONAL	+49-2822-6090
AMERICAS	CORPORATION http://www.brother-usa.com/	+1-908-704-1700