

LK3-B434E Mark II

INSTRUCTION MANUAL



Please read this manual before using the machine.
Please keep this manual within easy reach for quick reference.

ELECTRONIC LOCKSTITCH PATTERN TACKER

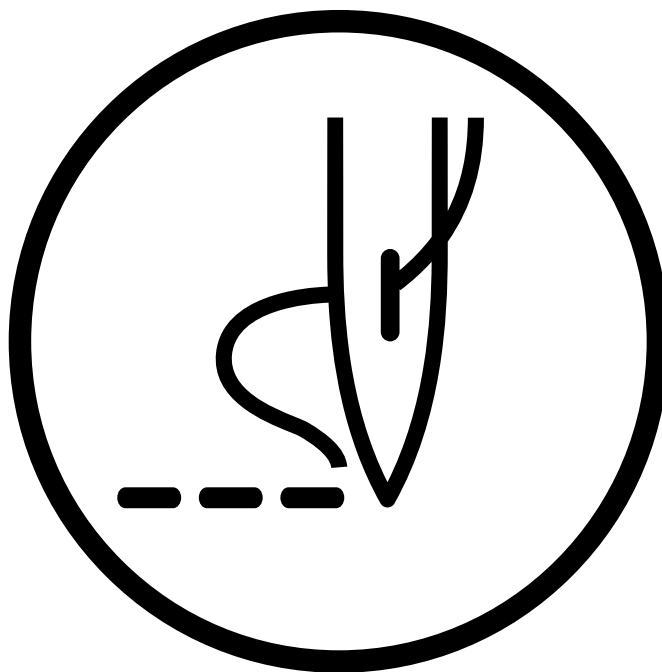

brother®

Thank you very much for buying a BROTHER sewing machine. Before using your new machine, please read the safety instructions below and the explanations given in the instruction manual.



With industrial sewing machines, it is normal to carry out work while positioned directly in front of moving parts such as the needle and thread take-up lever, and consequently there is always a danger of injury that can be caused by these parts. Follow the instructions from training personnel and instructors regarding safe and correct operation before operating the machine so that you will know how to use it correctly.

SAFETY INSTRUCTIONS



1. Safety indications and their meanings

This instruction manual and the indications and symbols that are used on the machine itself are provided in order to ensure safe operation of this machine and to prevent accidents and injury to yourself or other people. The meanings of these indications and symbols are given below.

Indications

 DANGER	The instructions which follow this term indicate situations where failure to follow the instructions will almost certainly result in death or severe injury.
 CAUTION	The instructions which follow this term indicate situations where failure to follow the instructions could cause injury when using the machine or physical damage to equipment and surroundings.

Symbols

-  This symbol (\triangle) indicates something that you should be careful of. The picture inside the triangle indicates the nature of the caution that must be taken.
(For example, the symbol at left means “beware of injury”.)
-  This symbol (\otimes) indicates something that you must not do.
-  This symbol (\bullet) indicates something that you must do. The picture inside the circle indicates the nature of the thing that must be done.
(For example, the symbol at left means “you must make the ground connection”.)

2. Notes on safety

DANGER



Wait at least 5 minutes after turning off the power switch and disconnecting the power cord from the wall outlet before opening the face plate of the control box. Touching areas where high voltages are present can result in severe injury.

CAUTION

Environmental requirements



Use the sewing machine in an area which is free from sources of strong electrical noise such as high-frequency welders. Sources of strong electrical noise may cause problems with correct operation.



Any fluctuations in the power supply voltage should be within $\pm 10\%$ of the rated voltage for the machine. Voltage fluctuations which are greater than this may cause problems with correct operation.



The power supply capacity should be greater than the requirements for the sewing machine's electrical consumption. Insufficient power supply capacity may cause problems with correct operation.



The pneumatic delivery capability should be greater than the requirements for the sewing machine's total air consumption. Insufficient pneumatic delivery capability may cause problems with correct operation.



The ambient temperature should be within the range of 5°C to 35°C during use. Temperatures which are lower or higher than this may cause problems with correct operation.



The relative humidity should be within the range of 45% to 85% during use, and no dew formation should occur in any devices. Excessively dry or humid environments and dew formation may cause problems with correct operation.



Avoid exposure to direct sunlight during use. Exposure to direct sunlight may cause problems with correct operation.



In the event of an electrical storm, turn off the power and disconnect the power cord from the wall outlet. Lightning may cause problems with correct operation.

Installation



Machine installation should only be carried out by a qualified technician.



Contact your Brother dealer or a qualified electrician for any electrical work that may need to be done.



The sewing machine weighs more than 49 kg. The installation should be carried out by two or more people.



Do not connect the power cord until installation is complete, otherwise the machine may operate if the foot switch is pressed by mistake, which could result in injury.



Hold the machine head with both hands when tilting it back or returning it to its original position. Furthermore, after tilting back the machine head, do not push the face plate side or the pulley side from above, as this could cause the machine head to topple over, which may result in personal injury or damage to the machine.



Be sure to connect the ground. If the ground connection is not secure, you run a high risk of receiving a serious electric shock, and problems with correct operation may also occur.



All cords should be secured at least 25 mm away from any moving parts. Furthermore, do not excessively bend the cords or secure them too firmly with staples, otherwise there is the danger that fire or electric shocks could occur.



Install the belt covers to the machine head and motor.



If using a work table which has casters, the casters should be secured in such a way so that they cannot move.













Be sure to wear protective goggles and gloves when handling the lubricating oil and grease, so that they do not get into your eyes or onto your skin, otherwise inflammation can result.

Furthermore, do not drink the oil or eat the grease under any circumstances, as they can cause vomiting and diarrhoea.



Keep the oil out of the reach of children.

CAUTION











Sewing

-  This sewing machine should only be used by operators who have received the necessary training in safe use beforehand.
-  The sewing machine should not be used for any applications other than sewing.
-  Be sure to wear protective goggles when using the machine.
If goggles are not worn, there is the danger that if a needle breaks, parts of the broken needle may enter your eyes and injury may result.
-  Set the needle to the needle up stop position before turning off the power.
If this is not done, the wiper may strike the needle, which might cause the needle to break.
-  Turn off the power switch at the following times, otherwise the machine may operate if the foot switch is pressed by mistake, which could result in injury.
 - When threading the needle
 - When replacing the needle and bobbin
 - When not using the machine and when leaving the machine unattended
-  If using a work table which has casters, the casters should be secured in such a way so that they cannot move.
-  Attach all safety devices before using the sewing machine. If the machine is used without these devices attached, injury may result.
-  Do not touch any of the moving parts or press any objects against the machine while sewing, as this may result in personal injury or damage to the machine.
-  If an error occurs in machine, or if abnormal noises or smells are noticed, immediately turn off the power switch. Then contact your nearest Brother dealer or a qualified technician.
-  If the machine develops a problem, contact your nearest Brother dealer or a qualified technician.

Cleaning

-  Set the needle to the needle up stop position before turning off the power.
If this is not done, the wiper may strike the needle, which might cause the needle to break.
-  Turn off the power switch before carrying out cleaning, otherwise the machine may operate if the foot switch is pressed by mistake, which could result in injury.
-  Be sure to wear protective goggles and gloves when handling the lubricating oil and grease, so that they do not get into your eyes or onto your skin, otherwise inflammation can result.
Furthermore, do not drink the oil or eat the grease under any circumstances, as they can cause vomiting and diarrhoea.
Keep the oil out of the reach of children.

Maintenance and inspection

-  Maintenance and inspection of the sewing machine should only be carried out by a qualified technician.
-  Ask your Brother dealer or a qualified electrician to carry out any maintenance and inspection of the electrical system.
-  Set the needle to the needle up stop position before turning off the power.
If this is not done, the wiper may strike the needle, which might cause the needle to break.
-  Turn off the power switch and disconnect the power cord from the wall outlet at the following times, otherwise the machine may operate if the foot switch is pressed by mistake, which could result in injury.
 - When carrying out inspection, adjustment and maintenance
 - When replacing consumable parts such as the rotary hook
-  Disconnect the air hoses from the air supply and wait for the needle on the pressure gauge to drop to "0" before carrying out inspection, adjustment and repair of any parts which use the pneumatic equipment.
-  If the power switch and air need to be left on when carrying out some adjustment, be extremely careful to observe all safety precautions.
-  Hold the machine head with both hands when tilting it back or returning it to its original position.
Furthermore, after tilting back the machine head, do not push the face plate side or the pulley side from above, as this could cause the machine head to topple over, which may result in personal injury or damage to the machine.
-  Use only the proper replacement parts as specified by Brother.
-  If any safety devices have been removed, be absolutely sure to re-install them to their original positions and check that they operate correctly before using the machine.
-  Any problems in machine operation which result from unauthorized modifications to the machine will not be covered by the warranty.

3. Warning labels

The following warning labels appear on the sewing machine. Please follow the instructions on the labels at all times when using the machine. If the labels have been removed or are difficult to read, please contact your nearest Brother dealer.

1

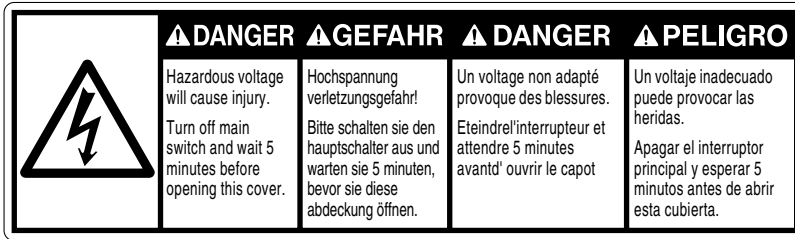

2

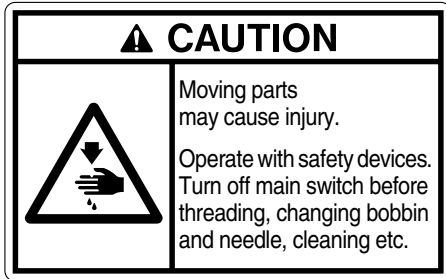

Safety devices

- Eye guard
- Finger guard
- Thread take-up cover
- Thread take-up solenoid cover
- Belt cover
- Motor cover, etc.

3



Be sure to connect the ground. If the ground connection is not secure, you run a high risk of receiving a serious electric shock, and problems with correct operation may also occur.

4



Direction of operation

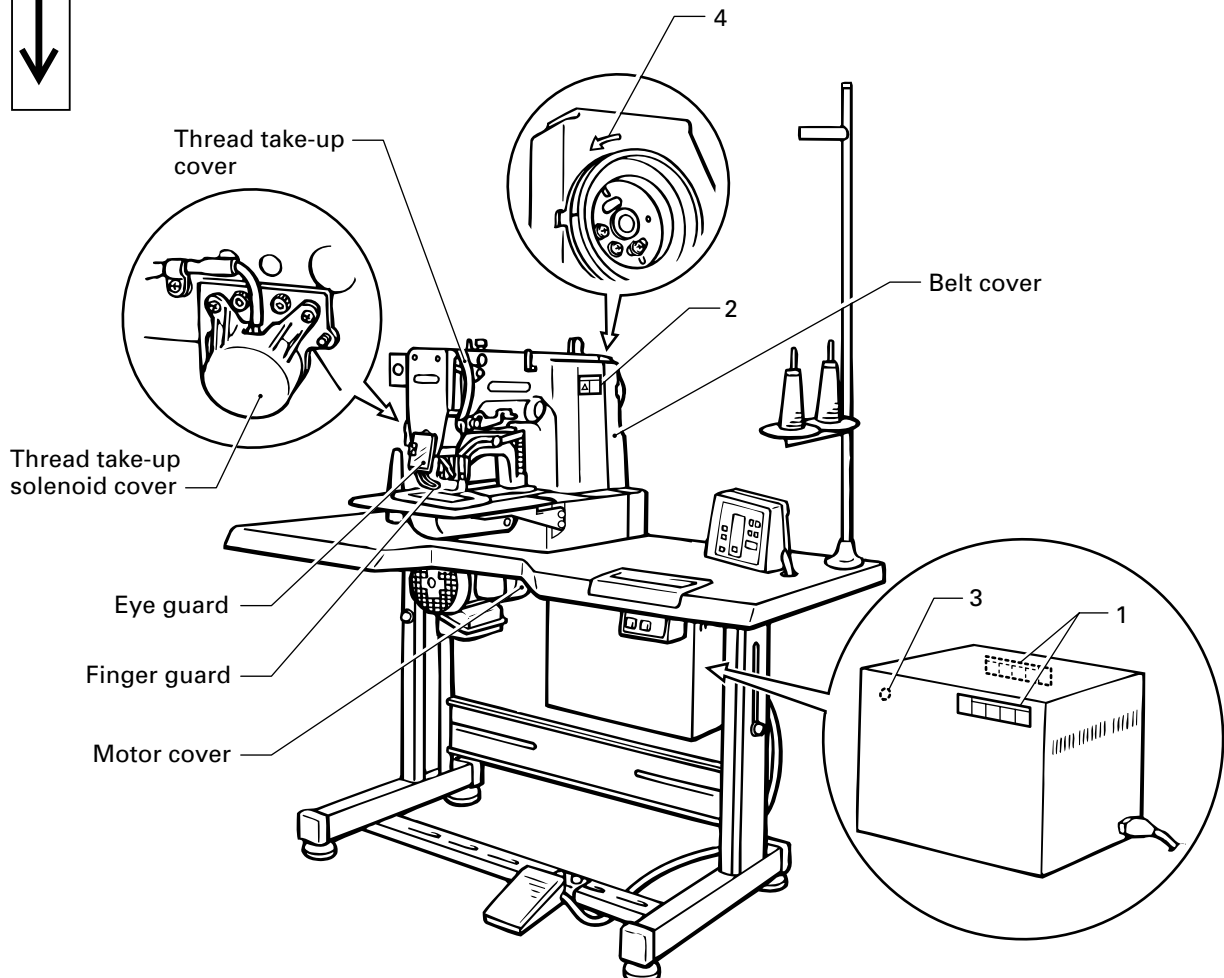

CONTENTS

<p>1. NAME OF EACH PART 1</p> <p>2. SPECIFICATIONS 2</p> <p style="padding-left: 20px;">2-1. Specifications 2</p> <p style="padding-left: 20px;">2-2. Examples of sewing patterns 3</p> <p>3. INSTALLATION 4</p> <p style="padding-left: 20px;">3-1. Power table 4</p> <p style="padding-left: 20px;">3-2. Installing the motor 5</p> <p style="padding-left: 20px;">3-3. Installing the motor pulley 5</p> <p style="padding-left: 20px;">3-4. Installing the control box 6</p> <p style="padding-left: 20px;">3-5. Installing the rubber cushions 7</p> <p style="padding-left: 20px;">3-6. Installing the oil pan 7</p> <p style="padding-left: 20px;">3-7. Installing the cushions 7</p> <p style="padding-left: 20px;">3-8. Installing the machine head 8</p> <p style="padding-left: 20px;">3-9. Installing the head rest 8</p> <p style="padding-left: 20px;">3-10. Installing the liquid cooling tank, optional 8</p> <p style="padding-left: 20px;">3-11. Installing the operation panel 9</p> <p style="padding-left: 20px;">3-12. Connecting the ground wire 9</p> <p style="padding-left: 20px;">3-13. Connecting the cords 10</p> <p style="padding-left: 20px;">3-14. Piping (for pneumatic) 12</p> <p style="padding-left: 20px;">3-15. Installing the V-belt 14</p> <p style="padding-left: 20px;">3-16. Installing the belt cover 15</p> <p style="padding-left: 20px;">3-17. Installing the foot switch 15</p> <p style="padding-left: 20px;">3-18. Installing the motor cover 16</p> <p style="padding-left: 20px;">3-19. Installing the spool stand 16</p> <p style="padding-left: 20px;">3-20. Installing the needle sub plate 17</p> <p style="padding-left: 20px;">3-21. Installing the eye guard 18</p> <p>4. LUBRICATION 19</p> <p style="padding-left: 20px;">4-1. Lubrication points 19</p> <p>5. OPERATION 20</p> <p style="padding-left: 20px;">5-1. Name and function of each operation panel item 20</p> <p style="padding-left: 20px;">5-2. Operating procedure 22</p> <p style="padding-left: 20px;">5-3. Operating the foot switch 23</p> <p style="padding-left: 20px;">5-4. Operating the emergency stop switch ... 24</p> <p>6. CHECKING THE SEWING PATTERN 25</p> <p>7. CORRECT USE 26</p> <p style="padding-left: 20px;">7-1. Selecting the needle and thread 26</p> <p style="padding-left: 20px;">7-2. Installing the needle 26</p> <p style="padding-left: 20px;">7-3. Threading the upper thread 26</p> <p style="padding-left: 20px;">7-4. Winding the lower thread 27</p> <p style="padding-left: 20px;">7-5. Replacing the bobbin case and threading the thread 28</p> <p style="padding-left: 20px;">7-6. Sewing conditions and thread tension 28</p> <p>8. SEWING 31</p> <p>9. MAINTENANCE AND INSPECTION 32</p> <p style="padding-left: 20px;">9-1. Cleaning the rotary hook 32</p>	<p style="padding-left: 20px;">9-2. Lubrication 33</p> <p style="padding-left: 20px;">9-3. Draining the oil 34</p> <p style="padding-left: 20px;">9-4. Cleaning the control box air inlet port 34</p> <p style="padding-left: 20px;">9-5. Cleaning the eye guard 34</p> <p style="padding-left: 20px;">9-6. Checking the needle 34</p> <p>10. STANDARD ADJUSTMENTS 35</p> <p style="padding-left: 20px;">10-1. Adjusting the needle bar height 35</p> <p style="padding-left: 20px;">10-2. Adjusting the needle bar lift amount 35</p> <p style="padding-left: 20px;">10-3. Adjusting the driver needle guard 36</p> <p style="padding-left: 20px;">10-4. Adjusting the needle clearance 36</p> <p style="padding-left: 20px;">10-5. Adjusting the shuttle race thread guide 36</p> <p style="padding-left: 20px;">10-6. Adjusting the thread take-up amount ... 37</p> <p style="padding-left: 20px;">10-7. Adjusting the movable knife 37</p> <p style="padding-left: 20px;">10-8. Adjusting the work clamp lift amount ... 40</p> <p style="padding-left: 20px;">10-9. Work clamp interchangeability 41</p> <p style="padding-left: 20px;">10-10. Adjusting the needle up stop position ... 41</p> <p style="padding-left: 20px;">10-11. Adjusting the thread wiper 42</p> <p style="padding-left: 20px;">10-12. Checking the input sensor and DIP switch input 43</p> <p style="padding-left: 20px;">10-13. Checking the input voltage 44</p> <p style="padding-left: 20px;">10-14. Clearing all memory settings 44</p> <p style="padding-left: 20px;">10-15. Moving stitch patterns 45</p> <p style="padding-left: 20px;">10-16. Adjustment of air pressure (for pneumatic) 46</p> <p style="padding-left: 20px;">10-17. Adjustment of inner clamping device 46</p> <p>11. USING THE COUNTERS 47</p> <p style="padding-left: 20px;">11-1. Using the bobbin thread counter 47</p> <p style="padding-left: 20px;">11-2. Using the production counter 47</p> <p>12. CHANGING FUNCTIONS USING THE DIP SWITCHES 48</p> <p style="padding-left: 20px;">12-1. Operation panel DIP switches 48</p> <p style="padding-left: 20px;">12-2. DIP switches inside the control box 49</p> <p style="padding-left: 20px;">12-3. Using user programs 50</p> <p>13. CHANGING SPECIAL FUNCTIONS USING THE MEMORY SWITCHES 52</p> <p style="padding-left: 20px;">13-1. Using the cycle sewing function 55</p> <p>14. SETTING THE WORK CLAMP MODE 57</p> <p style="padding-left: 20px;">14-1. Setting solenoid work clamp mode ... 57</p> <p style="padding-left: 20px;">14-2. Setting pneumatic work clamp mode 57</p> <p style="padding-left: 20px;">14-3. Light work clamp 58</p> <p style="padding-left: 20px;">14-4. Setting reverse work clamp mode 59</p> <p>15. TABLE OF ERROR CODES 60</p> <p>16. GAUGE PARTS LIST ACCORDING TO SUBCLASSES 62</p> <p>17. TROUBLESHOOTING 65</p> <p>18. OPTIONAL PARTS 68</p>
---	---

1. NAME OF EACH PART

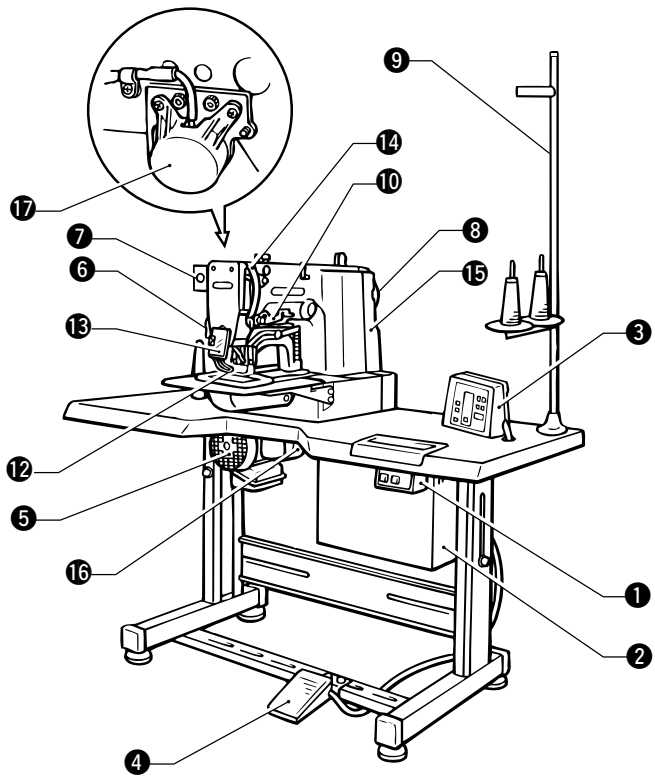

[LK3-B434E Mark II/Solenoid specifications]

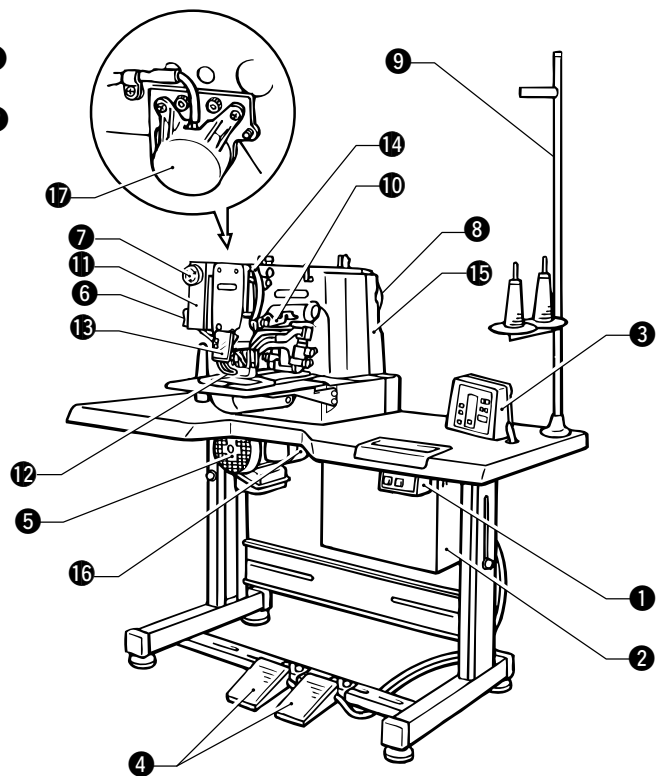
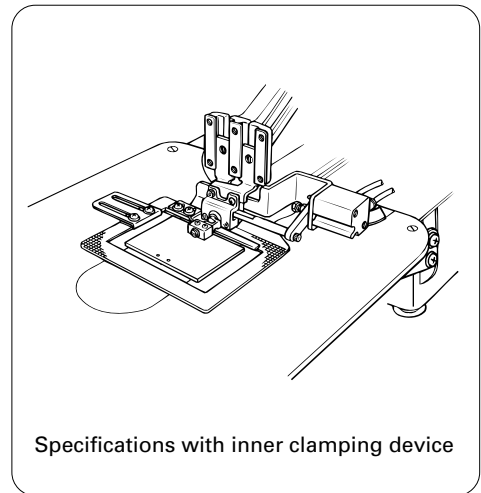

[LK3-B434E Mark II/Pneumatic specifications]

- ① Power switch
- ② Control box
- ③ Operation panel
- ④ Foot switch
- ⑤ Motor
- ⑥ Tension release lever
- ⑦ EMERGENCY STOP switch
- ⑧ Pulley
- ⑨ Spool stand
- ⑩ Thread take-up lever
- ⑪ Wiper solenoid cover

Safety devices;

- ⑫ Finger guard
- ⑬ Eye guard
- ⑭ Thread take-up cover
- ⑮ Belt cover
- ⑯ Motor cover
- ⑰ Thread take-up solenoid cover

2. SPECIFICATIONS

2-1. Specifications



1	Medium materials
2	Heavy materials

Stitch formation	Single needle lock stitch
Maximum sewing speed	2,500 rpm (Pitch 3 mm)
Maximum pattern size	100 × 60 mm max.
Feed mechanism	R-θ intermittent feed mechanism (pulse-motor driven mechanism)
Stitch length	0.1 - 10.0 mm
Number of stitches	Variable
Maximum stitch number	20,000 stitches (including 10,000 stitches which can be added)
Work clamp lifter	Solenoid type or pneumatic type
Work clamp height	17 mm max. (for solenoid), 25 mm max. (for pneumatic) (Max. 17 mm for inner clamping device)
Rotary hook	Shuttle hook (shuttle hook 2, optional)
Wiper device	Standard equipment
Thread trimmer device	Standard equipment
Thread take-up device	Standard equipment
Safety device	built-in stopping mechanism
Data storage method	P-ROM (Any sewing pattern can be added using BAS-PC/300.)
Number of user programs	16
Number of cycle programs	4
Number of stored data	Up to 100 patterns can be added. Total number of stitches of stored data which can be added is within 10,000.
Motor	Three-phase 400W induction motor
Weights	Machine head: 49 kg, Operation panel: 0.6 kg, Control box: 9 - 19 kg (depending on destination)
Power source	Single-phase 220 - 230V 3-phase 220, 380, 400, 415V Maximum electric power consumption; 600VA

[Main use]

Patterns up to a maximum size of 100 mm × 60 mm can be sewn.

For plain stitching of small articles, curtain darts, etc.

Two-stage work clamp, light work clamp and inner clamping device can be used (for pneumatic).

For attaching items, sewing labels, etc.

If you want to sew a pattern, you can create your original pattern using the BAS-PC/300.

Consult with your local Brother Sales Office for details.

2. SPECIFICATIONS

2-2. Examples of sewing patterns

The following are examples of possible patterns with the LK3-B434E Mark II.

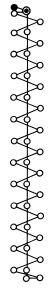
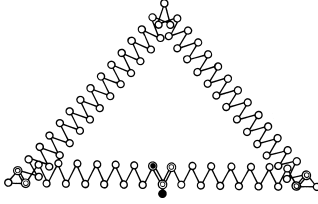
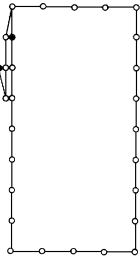
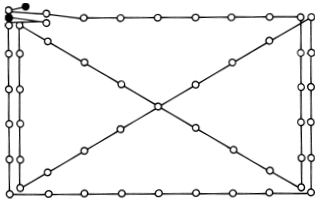
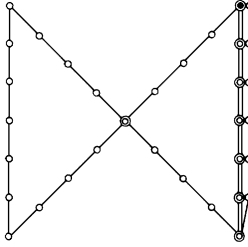
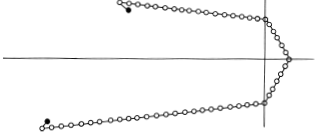
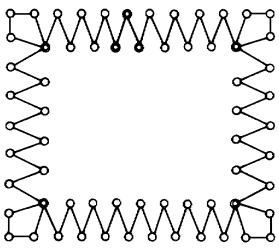
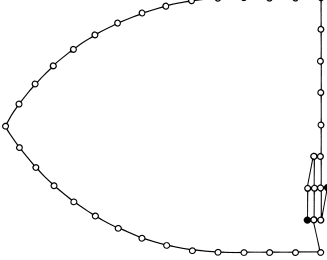
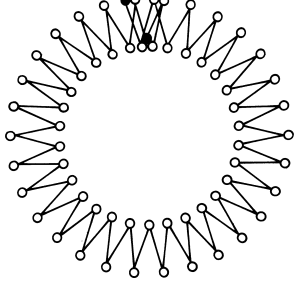
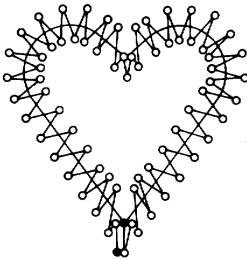
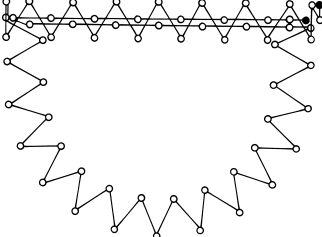
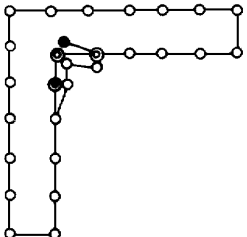
Sewing patterns			
Uses	Decorative tacking	Triangular chain tacking	Rectangular decorative tacking
Number of stitches	42	98	28
Sewing patterns			
Uses	Cross tacking	Open cross tacking	Buckle stitching
Number of stitches	56	42	56
Sewing patterns			
Uses	Square tacking	Bullet-nose tacking	Round tacking
Number of stitches	63	42	63
Sewing patterns			
Uses	Heart-shaped tacking	Half-moon tacking	L-shaped tacking
Number of stitches	70	64	28

3. INSTALLATION

⚠ CAUTION

- ⊘ Machine installation should only be carried out by a qualified technician.
- ⚠ Contact your Brother dealer or a qualified electrician for any electrical work that may need to be done.
- ⚠ The sewing machine head weighs more than 49 kg. The installation should be carried out by two or more people.
- ⊘ Do not connect the power cord until installation is complete, otherwise the machine may operate if the foot switch is depressed by mistake, which could result in injury.
- ⚠ Hold the machine head with both hands when tilting it back or returning it to its original position. Furthermore, after tilting back the machine head, do not push the face plate side or the pulley side from above, as this could cause the machine head to topple over, which may result in personal injury or damage to the machine.
- ⚠ All cords should be secured at least 25 mm away from any moving parts. Furthermore, do not excessively bend the cable or secure it too firmly staples, otherwise there is the danger that fire or electric shocks could occur.
- ⚠ Be sure to connect the ground. If the ground connection is not secure, you run the risk of receiving a serious electric shock, and problems with correct operation may also occur.
- ⚠ Install the belt covers to the machine head and motor.

3-1. Power table

- Use the power table which has been specially designed for each sewing machines.
- * If using a commercially-available table, process it as shown in the illustration below.

	Model code
Table/ legs assembly	127-V30-00001

NOTE:

The thickness of the table should be at least 40 mm, and it should be strong enough to bear the weight and vibration of the sewing machine.
 If the distance A between the insides of the legs is less than 740 mm, move the control box installation position closer to the motor (B = 247 mm).
 Check that the control box is at least 10 mm away from the leg. If the control box and leg are touching, it could cause the sewing machine to operate incorrectly.

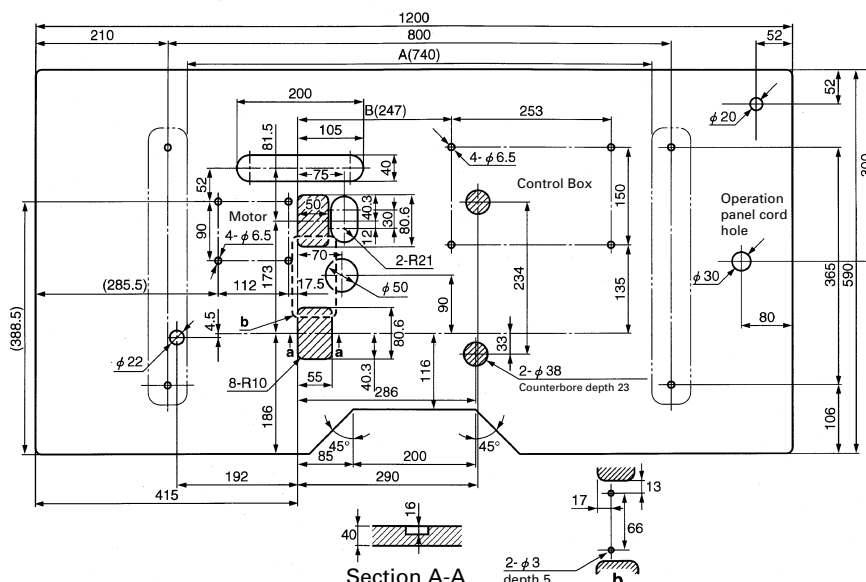

3. INSTALLATION

3-2. Installing the motor

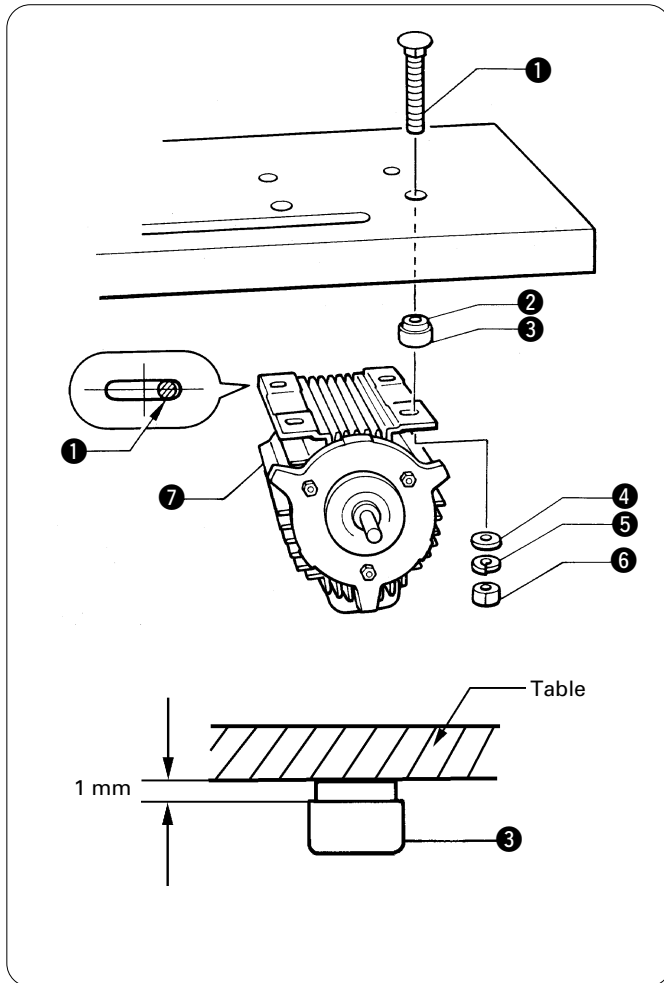

Install the motor ⑦ to the work table with the four accessory bolts ①, cushions ②, cushion collars ③, flat washers ④, spring washers ⑤ and nuts ⑥. At that time, fix by setting bolts ① a little to the right of oval hole on motor.

NOTE:

Tighten the nuts ⑥ so that the clearance between the table and the cushion collars ③ is approximately 1 mm.

3-3. Installing the motor pulley

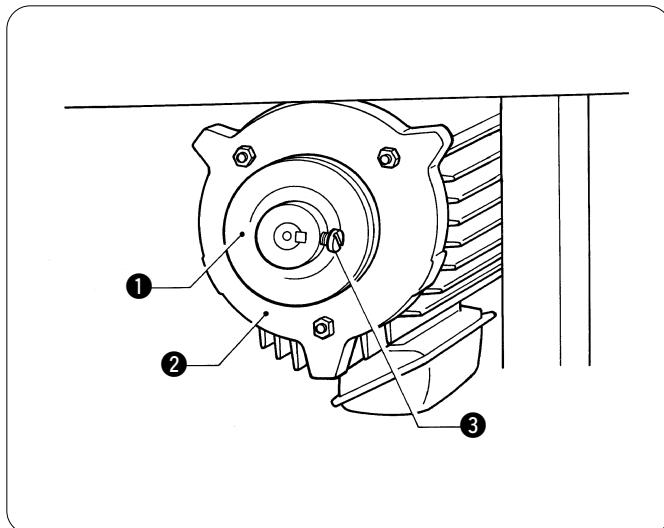

Place the motor pulley ① onto the shaft of the motor ② so that the key groove is aligned, and then tighten the set screw ③ so that the center of the V groove in the motor pulley ① is aligned as closely as possible with the center of the belt hole in the power table.

3-4. Installing the control box

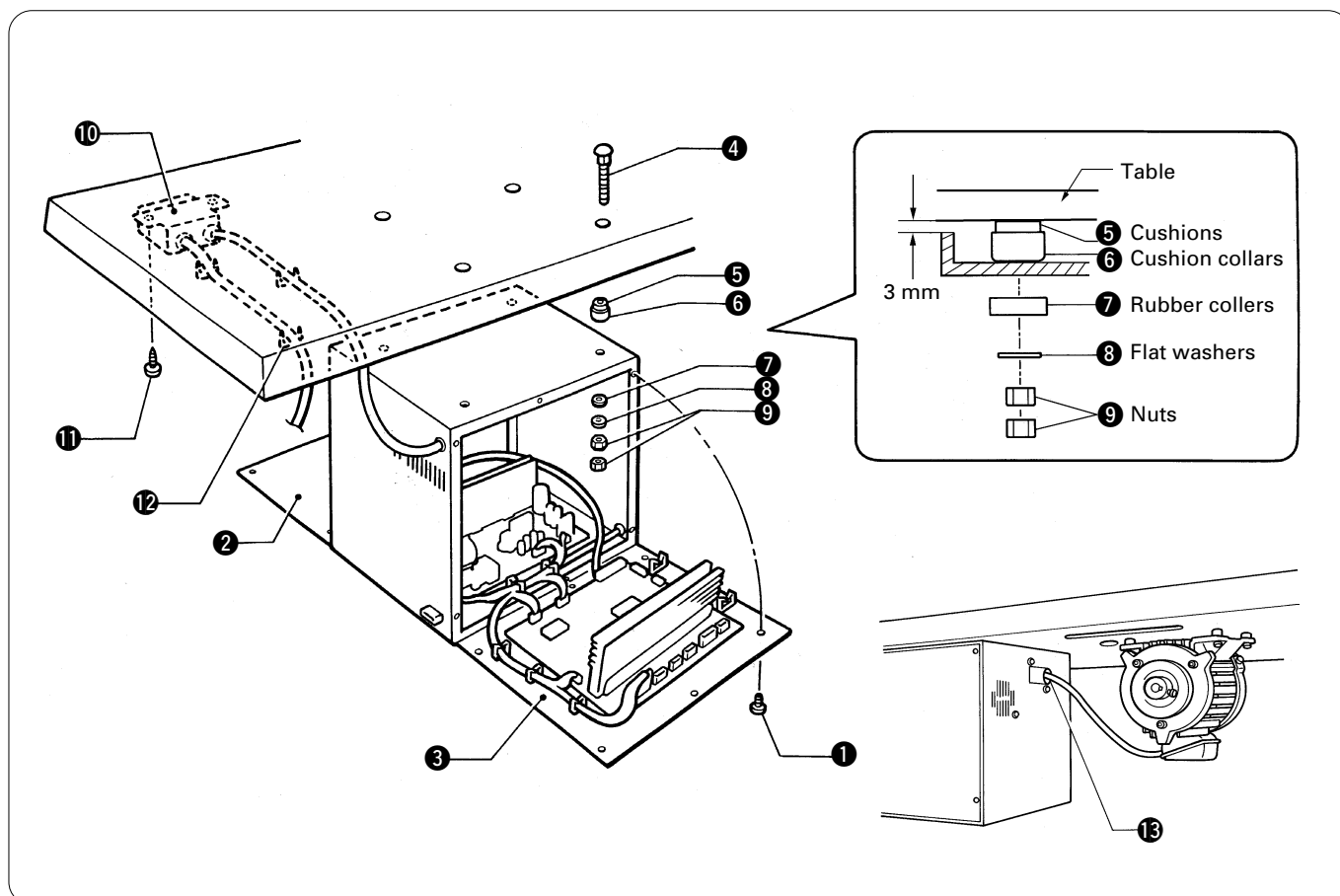

1. Remove the 12 screws ①, and then open the covers (panel mounting assembly ② and main P.C. board mounting plate ③).

NOTE:

When opening the cover, hold it securely so that it does not fall down.

2. Install the control box with the four accessory bolts ④, cushions ⑤, cushion collars ⑥, rubber collars ⑦, flat washers ⑧ and nuts ⑨ as shown in the illustration above. At this time, leave a gap of approximately 3 mm between the work table and the top of the box.
 - * Use two nuts ⑨ at each installation location, and make sure that both nuts are tightened.
3. Close the covers (panel mounting assembly ② and main P.C. board mounting plate ③), and tighten them with the screws ①.
 - * The main P.C. board mounting plate ③ will be opened again during "3-13. Connecting the cords", so provisionally tighten it with the screw ①.
4. Install the power switch ⑩ with the two screws ⑪.
5. Secure the power switch cord with the three staples ⑫.
6. Pass the motor cord through the cord hole ⑬.

3. INSTALLATION

3-5. Installing the rubber cushions

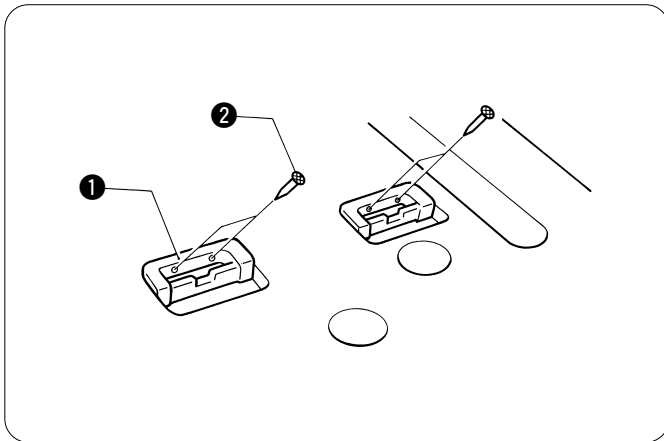

Install the rubber cushions ① with the nails ②.

3-6. Installing the oil pan

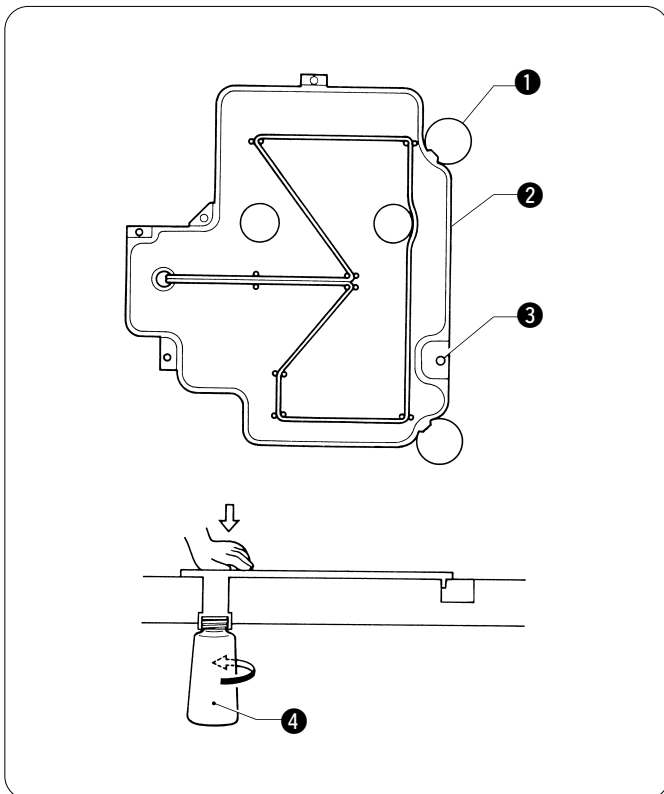

1. Insert the tabs of the oil pan ② into the holes for the cushions ①, and then secure it in place with the five nails ③ so that the oil pan ② is not at an angle.
2. While pushing the oil pan ② down from above, screw in the oil container ④.

3-7. Installing the cushions

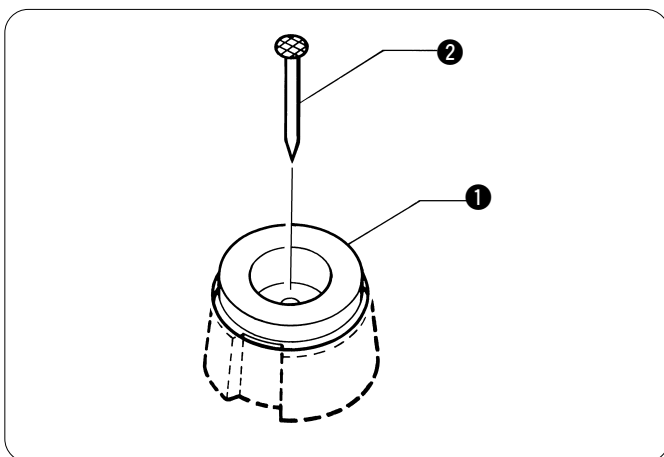

Place the two cushions ① into the holes in the work table so that the notches are aligned with the tabs in the oil pan, and secure them in place with the nails ②.

3-8. Installing the machine head

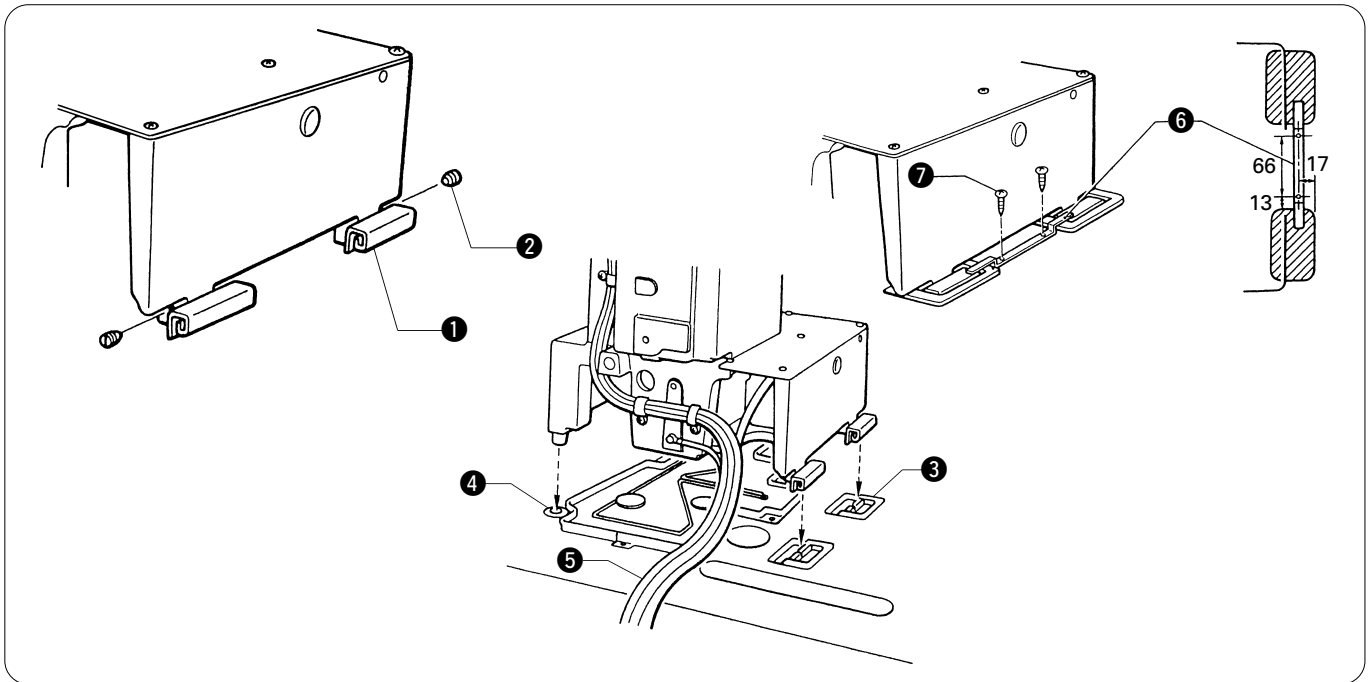

1. Insert the head hinges **1** into the machine head so that they are parallel, and then secure them with the two set screws **2**.
2. Place the machine head gently on top of the rubber cushions **3** and cushions **4**.
NOTE:
 Pull the cords **5** out as shown in the illustration above in order to prevent them from being clamped by the machine head.
3. Install the hinge presser **6** with the two screws **7**.

3-9. Installing the head rest

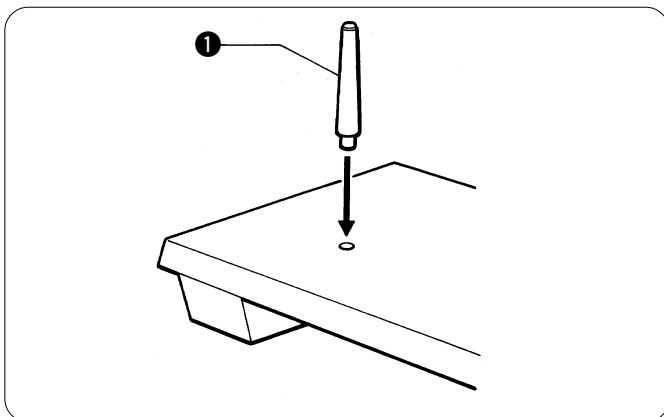

Tap the head rest **1** into the table hole.

NOTE:

Tap the head rest securely into the table hole.

3-10. Installing the liquid cooling tank, optional

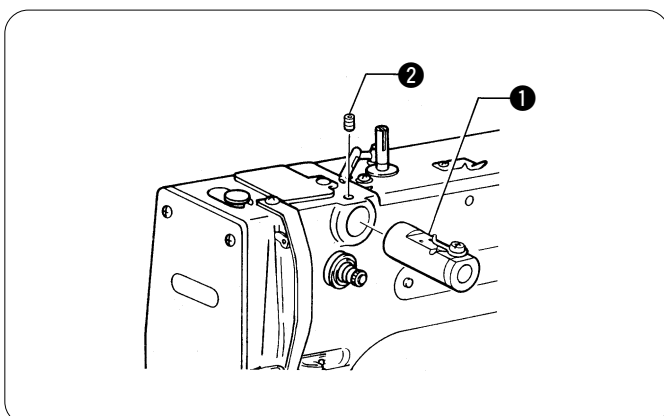

1. Remove the rubber plug, and then push the liquid cooling tank **1**.
2. Tighten it with the set screw **2**.

3. INSTALLATION

3-11. Installing the operation panel

The operation panel can be installed to either the top or bottom of the work table.

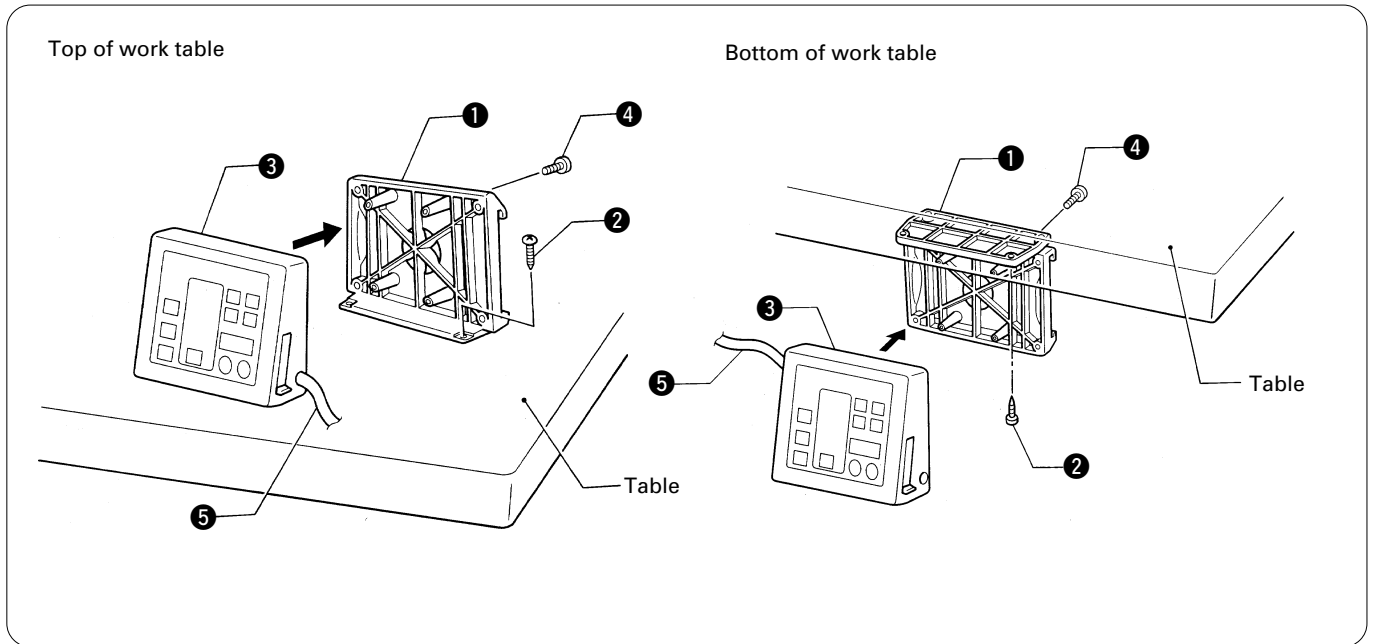

1. Install the rear frame **1** to the work table (top or bottom) with the four wood screws **2**.
2. Install the front frame **3** to the rear frame **1** with the four screws **4**.
* The vertical orientation of the front frame **3** is the same whether it is installed to the top or the bottom of the work table.
3. Insert the connector cord **5** into the control box through the hole at the side of the box. Refer to "3-13. Connecting the cords" for details on connecting the cord.
4. Secure the connector cord **5** with the staples (in three places).

3-12. Connecting the ground wire

CAUTION



Be sure to connect the ground. If the ground connection is not secure, you run the risk of receiving a serious electric shock, and problems with correct operation may also occur.

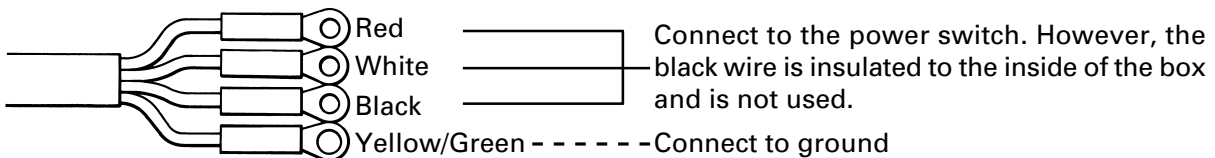

3-13. Connecting the cords

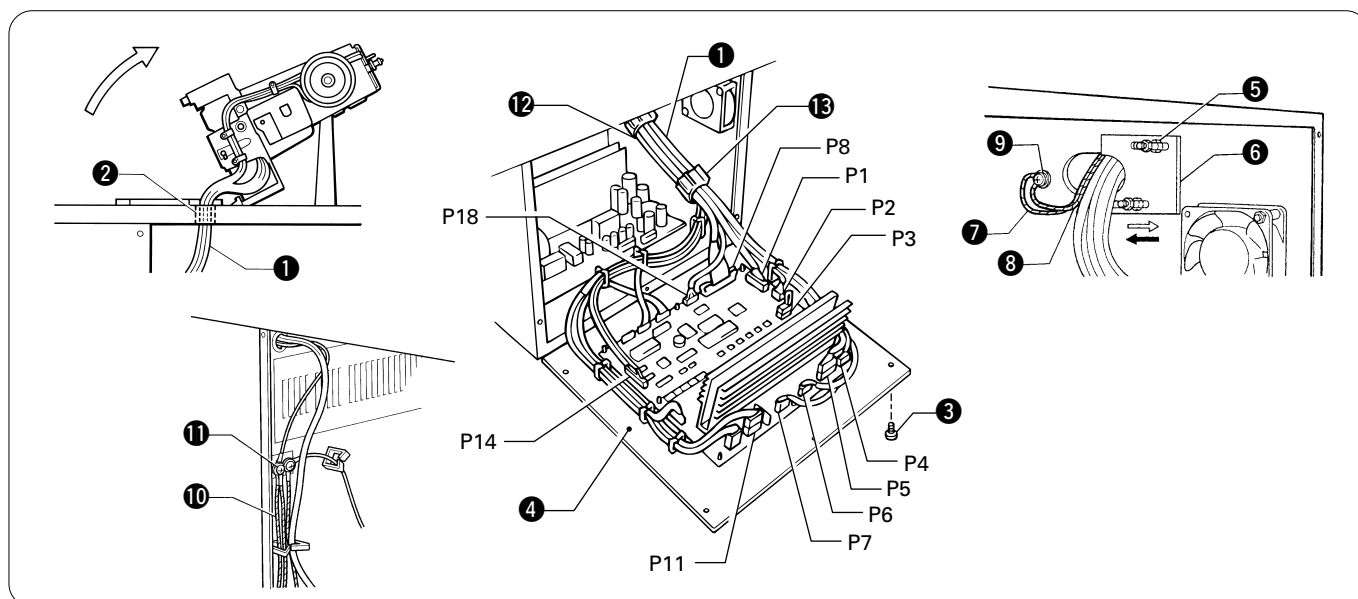

1. Gently tilt back the machine head.

NOTE:

After tilting back the machine head, do not push the face side or the pulley side from above.

2. Pass the cords ① through the hole ② in the work table.
3. Gently return the machine head to its original position.
4. Remove the six screws ③, and then open the control box cover (main P.C. board mounting plate ④).

NOTE:

When opening the cover, hold it securely so that it does not fall down.

5. Loosen the two screws ⑤, and then open the cord presser plate ⑥ in the direction of the white arrow and pass the cords ① through the opening.
6. Loosen the screw ⑨, and then attach the ground cord ⑦ for the machine head and the ground cord ⑧ for the operation panel as shown in the illustration.
7. Loosen the screw ⑩, and then attach the ground cord ⑩ for the upper shaft motor as shown in the illustration.
8. Securely connect connectors P1 to P8, P11, P14 (for pneumatic) and P18 as indicated in the table.

Machine head connectors			Connection location on circuit board
Connection location	No. of pins	Cord mark	
X, Y, Sewing sensor	12-pin	①	P1 (ORG2)
Synchronizer	5-pin	②	P2 (SYNCHRO)
Machine specification select connector	8-pin	③	P3 (SELECT)
Thread wiper solenoid* Thread take-up solenoid	5-pin	④	P4 (SOL2)
Presser solenoid Thread trimmer solenoid	4-pin	⑤	P5 (SOL)
Pulse motor, Y	4-pin (blue)	⑥	P6 (YPM)
Pulse motor, X	4-pin	⑦	P7 (XPM)
Operation panel	26-pin	None	P8 (PANEL)
Upper shaft motor	3-pin	None	P11 (UVW)
EMERGENCY STOP switch	6-pin	⑱	P18 (HEAD)
Solenoid valve (for pneumatic)	12-pin	None	P14 (AIR)

* Provided as an option for solenoid specifications.

9. Secure the cords ① with the cord clamps ⑫ and ⑬.
10. Close the cord presser plate ⑥ in the direction of the black arrow, and secure it by tightening the screws ⑤.

NOTE:

Check that the cords do not get pulled when the machine head is tilted back gently.

3. INSTALLATION

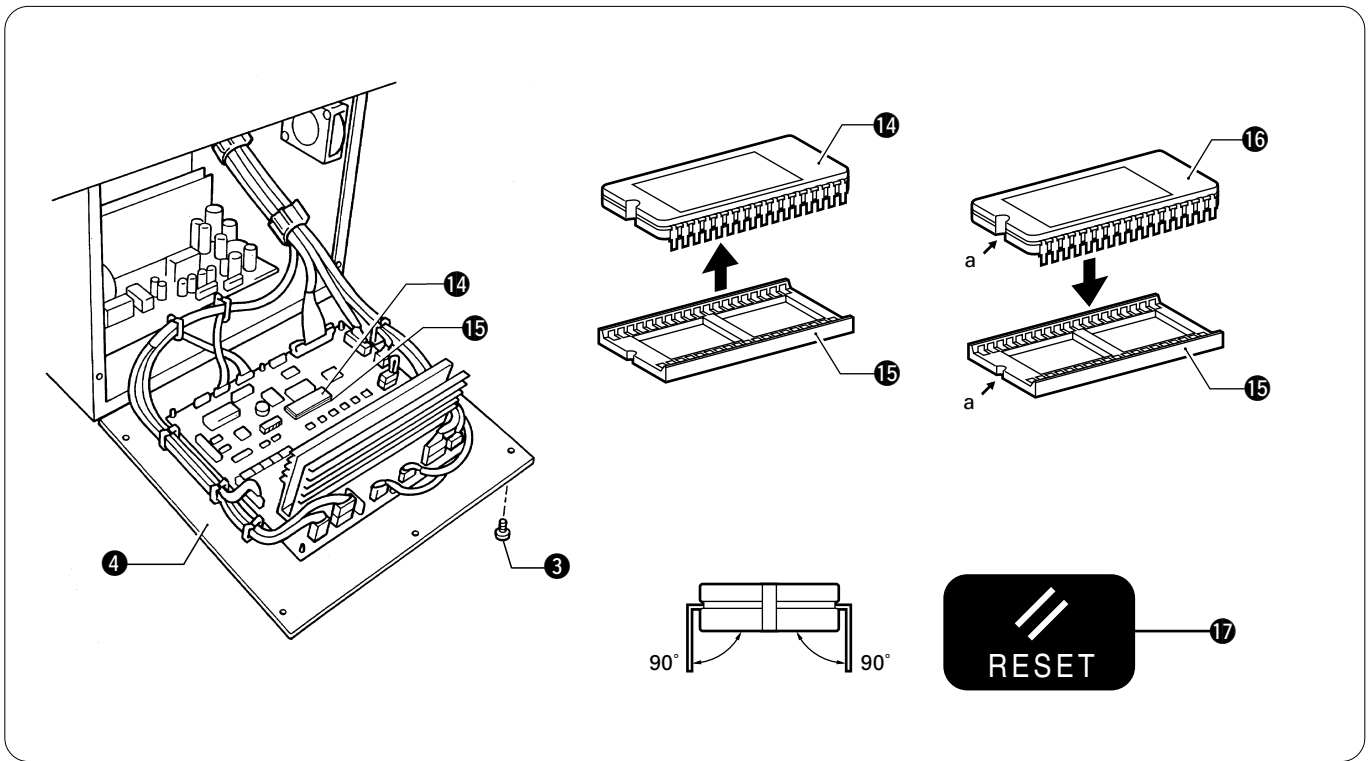

11. Replace PROM control assembly with one which contains sewing data.

1) Use the special tool to remove the PROM control assembly 14 from the PROM socket 15.

* Store the removed PROM control assembly in the special case provided.

2) Bend the pins of the PROM control assembly which contains sewing data 16 so that they are at an angle of approximately 90°.

3) Make the directions of the PROM control assembly 16 and the PROM socket 15 same so that the portions (a) come on the same side, and press the PROM gently into the socket while checking that the pins of the PROM are going into the socket properly.

NOTE:

- If the PROM has been replaced, press the RESET switch 17 while turning on the power in order to initialize the memory.

All of the user programs, cycle programs and memory switches which have been recorded will then be cleared.

- The PROM which is installed at the time of shipment from the factory does not include any sewing data. If you try to change the program number without replacing the PROM, error "E-b1" will be displayed. To create sewing data, use the BAS-PC/300 electronic pattern sewer/reader (sold separately).

12. Tighten the cover (main P.C. board mounting plate 4) with the six screws 3.

3-14. Piping (for pneumatic)

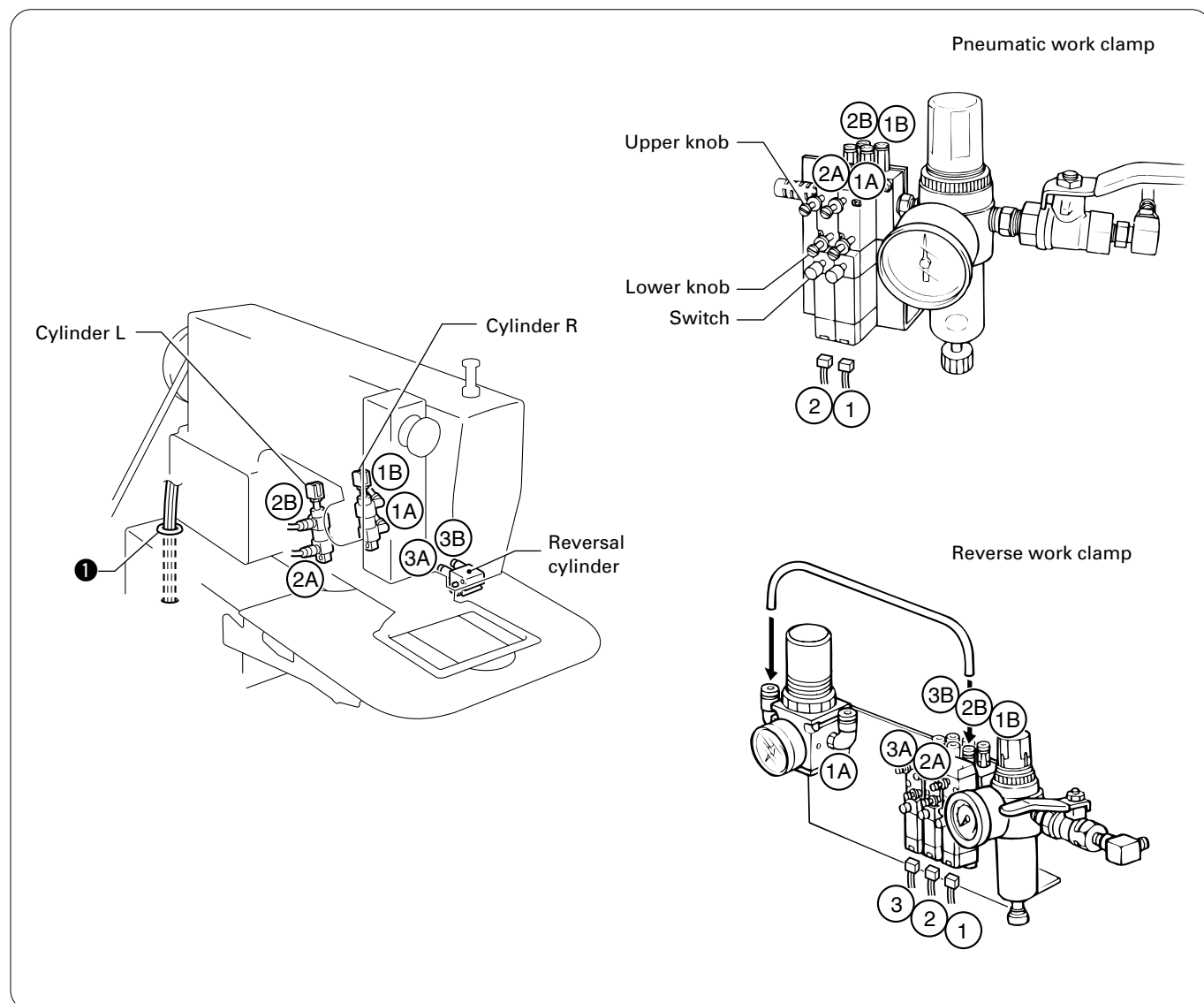

Connect air tubes in accordance with the identified numbers in the figure. At this time, pass the air tubes through the hole ❶ and then pass it through the work table hole.

- * After connecting the air tubes, bind them together with the fastening band.
- * Light work clamp mode can be used by changing over the air tube connections.
(Refer to "14. Setting the work clamp mode".)

3. INSTALLATION

3-14-1. Installing the air unit

Make sure that the air unit does not touch the control box or the work table leg.

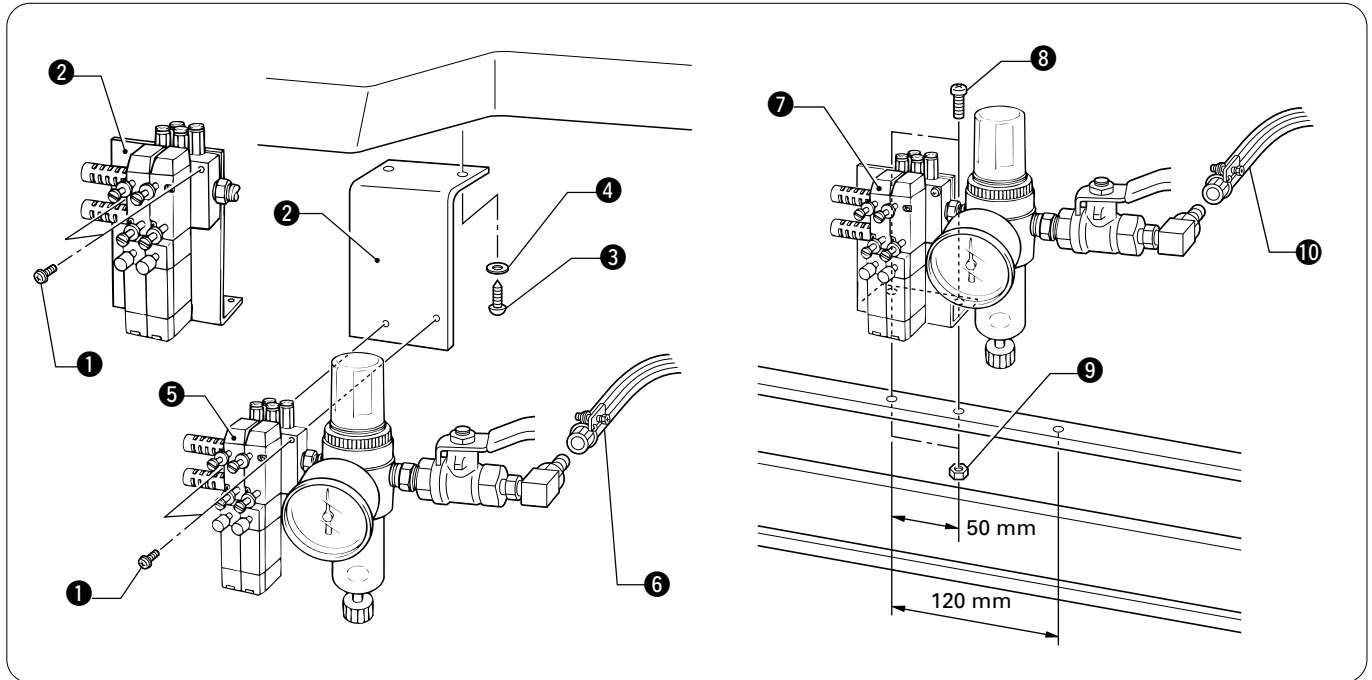

■ When installing to the underside of the work table

1. Remove the two screws ① and the valve setting plate ②.
2. Turn the valve setting plate ② upside down, and install it to the underside of the work table using the two wood screws ③ and washers ④ which are provided as accessories.
3. Install the air unit ⑤ to the valve setting plate ② with two screws ①.
4. Connect the air hose ⑥.
5. Adjust the air pressure. (Refer to "10-16. Adjusting the air pressure".)

■ When installing to a beam

1. Make holes in the beam as shown in the illustration above. (Button hole diameter is 5.4 mm.)
Pneumatic work clamp Pitch 50 mm Reverse work clamp Pitch 120 mm
2. Install the air unit ⑦ to the beam with two accessory screws ⑧ and two bolts ⑨.
3. Connect the air hose ⑩.
4. Adjust the air pressure. (Refer to "10-16. Adjusting the air pressure".)

3-14-2. Adjusting the speed controller

The speeds at which the work clamps are raised and lowered can be adjusted by loosening or tightening the valve control knobs. The speeds should be adjusted to speeds which are suitable for the intended application.

- If the upper control knob is tightened, the raising speed becomes slower; if it is loosened, the raising speed becomes faster.
- If the lower control knob is tightened, the lowering speed becomes slower; if it is loosened, the lowering speed becomes faster.
- When the power is turned off, the work clamps can be operated by pressing the switch.

NOTE:

Pneumatic specifications

Adjust the control knobs so that the left and right work clamps both operate at the same speed.

Specifications with inner clamping device

First, adjust the speed for the reverse work clamp. (Valve 1)

Next, turn on the power and then adjust the speed of the left work clamp. (Valve 2)

Adjust the control knobs so that the lowering speed of the left work clamp becomes faster than that of the reverse work clamp and the raising speed of it becomes slower than that of the reverse work clamp.

Next, adjust the control knobs so that the reverse work clamp operates more quickly. (Valve 3)

3-15. Installing the V-belt

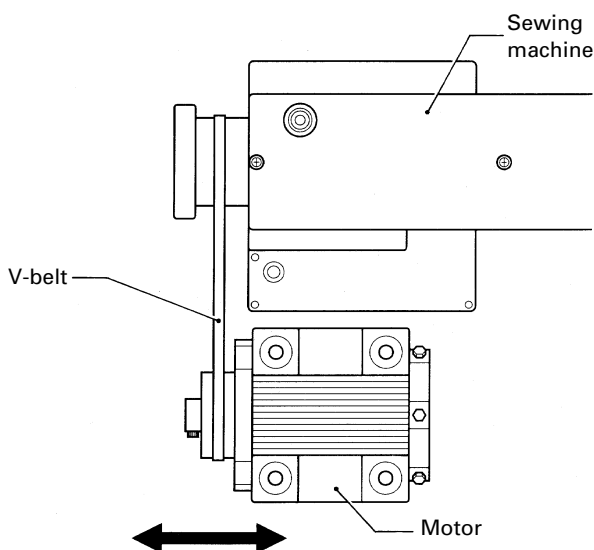
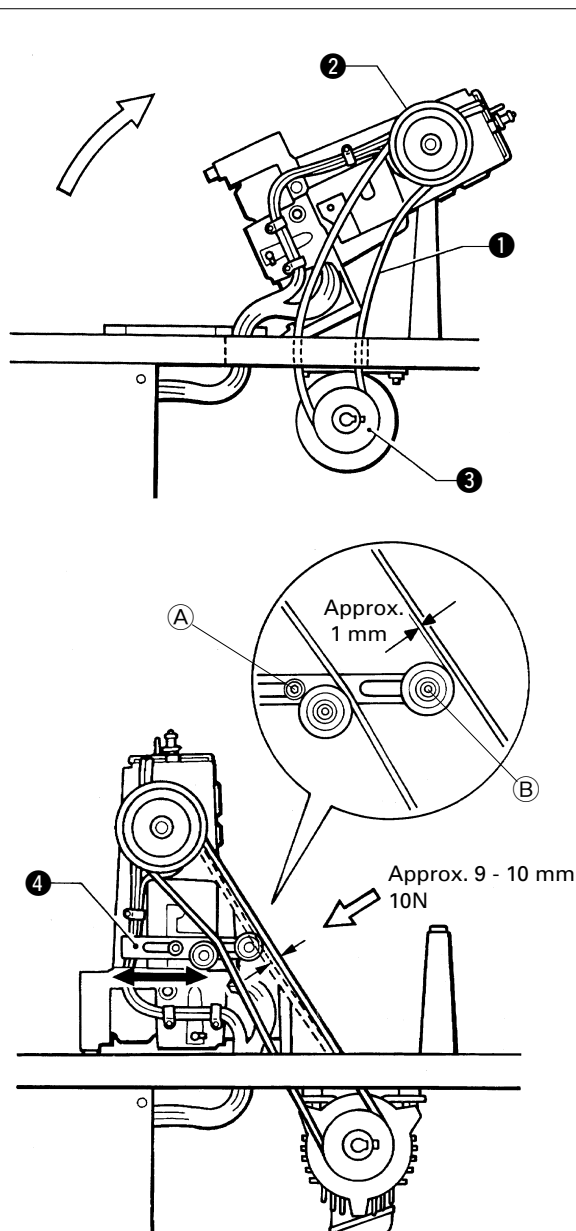

Fig.1

1. Gently tilt back the machine head, and then place the V-belt ① into the V grooves on the machine head pulley ② and the motor pulley ③.

NOTE:

After tilting back the machine head, do not push the face plate side or the pulley side from above.

2. Gently return the machine head to its original position.
* Be careful not to clamp the cords at this time.
3. Provisionally install the accessory tension pulley assembly ④ with the accessory flat washer, spring washer and bolt.
4. Adjust the belt tension by moving the tension pulley assembly to the right and left so that there is 9 - 10 mm of deflection in the V-belt ① when it is gently pushed in the middle with a force of approximately 10 N. After adjusting, tighten the bolt ⑤ to secure the left pulley assembly.
5. Move the right tension pulley so that there is a gap of about 1 mm between it and the V-belt ①, and then tighten the bolt ⑥ to secure the right pulley assembly.

NOTE:

Use brother specified V-belt (belt, VM).

The V-belt ① may stretch slightly when it is first used, so adjust the belt tension after about 3,000 cycles of use.

When above belt tension is weak, this will be cause of following problems;

- Noise & vibration become large.
- Needle up stop position becomes unstable.
- Error message [E-50] is displayed.

Check that the motor is positioned so that the V-belt is straight. (Fig.1)

3. INSTALLATION

3-16. Installing the belt cover

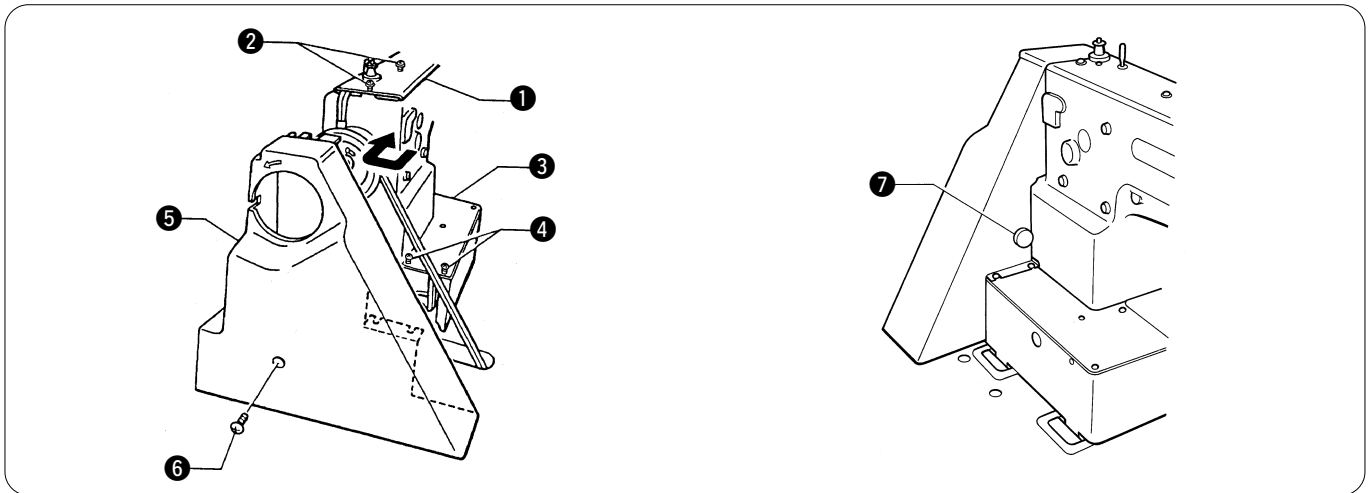

1. Loosen the two screws **2** of the upper cover **1** and the two screws **4** of bed cover **3**.
2. Insert the belt cover **5** in the direction of the arrow, and then secure it with the two screws **2**, the two screws **4** and the screw **6**.
* When tilting back the machine head, loosen the screws **2** and **4**, remove the screw **6** and then remove the belt cover **5** first.
3. Attach the rubber plug **7** to the belt cover.

3-17. Installing the foot switch

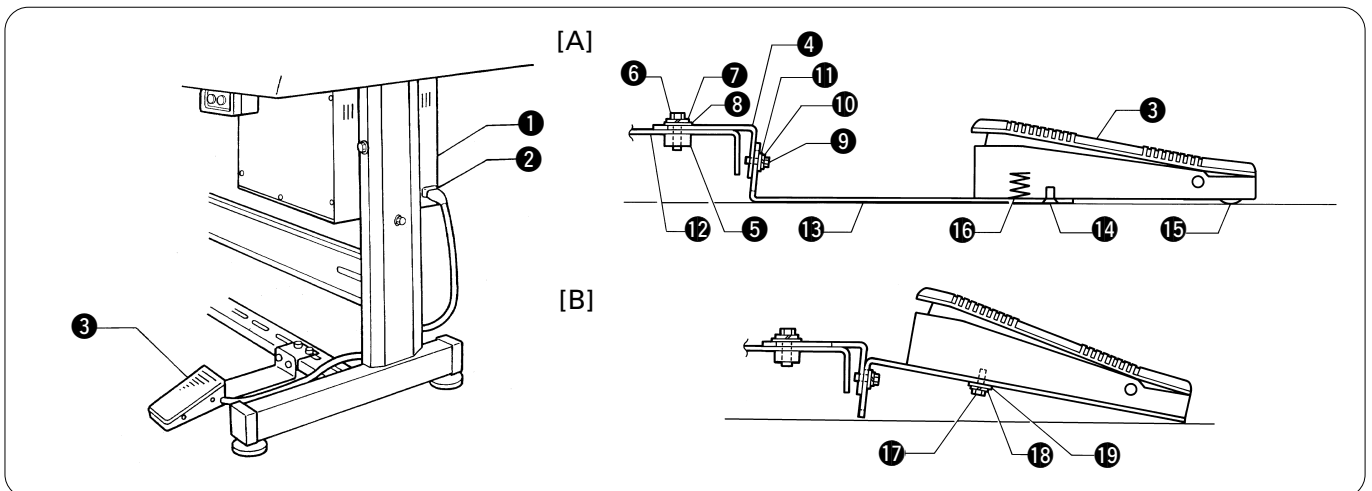

1. Insert the connector of the foot switch **3** into the connector **2** of the control box **1**.
2. Install the foot switch **3** to the work table leg **12** with foot switch support plate A **4**, foot switch support plate C **5**, the bolt **6**, spring washer **7**, flat washer **8**, bolt **9**, spring washer **10** and flat washer **11** as shown in Figure A.

◆ If foot switch support plate B **13** is used in a back-to-front position, it can be used as shown in Figure B.

1. Remove the screw **14** and rubber plug **15**.
* Note that the spring **16** will come out when the screw **14** is removed.
2. Turn foot switch support plate B **13** back to front, and then install it with the bolt **17**, spring washer **18** and flat washer **19** as shown in Figure B.

NOTE:

If using the foot switch without installing it to the work table leg, move the foot switch at least 10 mm away from the leg. If the foot switch is not fully in contact with the work table leg when the foot switch is used, for example, if it is just hooked loosely onto the work table leg, it may cause the sewing machine to operate incorrectly.

If using the two-pedal foot switch as an option for solenoid specifications, change the setting of DIP switch A on the operation panel while referring to "Setting the work clamp mode" on page 57.

3-18. Installing the motor cover

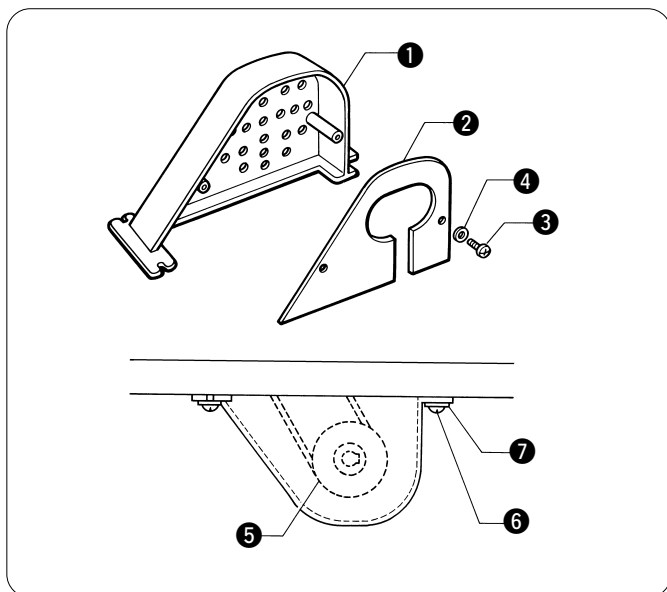

1. Install the motor cover **1** to the motor back cover **2** with the screws **3** and the flat washers **4**.
2. Pass the motor shaft through the notch in the motor back cover **2**, and then tighten the screws **6** and the washers **7** so that the clearance between the motor pulley **5** and the motor cover **1** is uniform.

3-19. Installing the spool stand

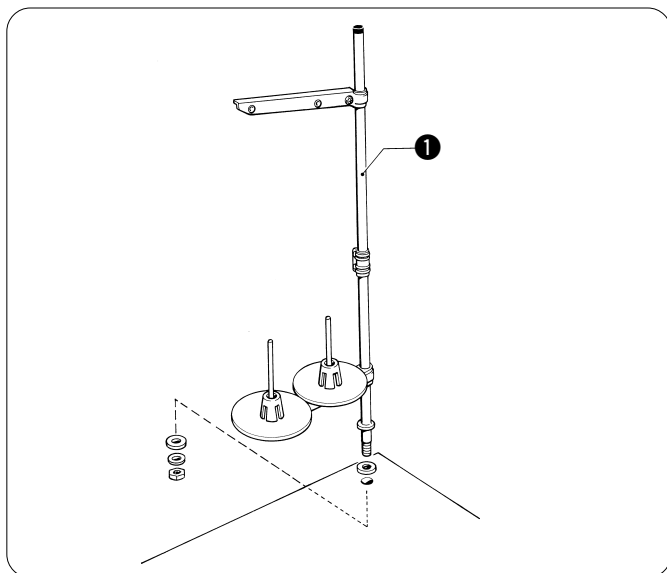

Assemble the spool stand **1** while referring to the spool stand instruction manual, and then install the spool stand **1** at the right side of the work table.

3. INSTALLATION

3-20. Installing the needle sub plate

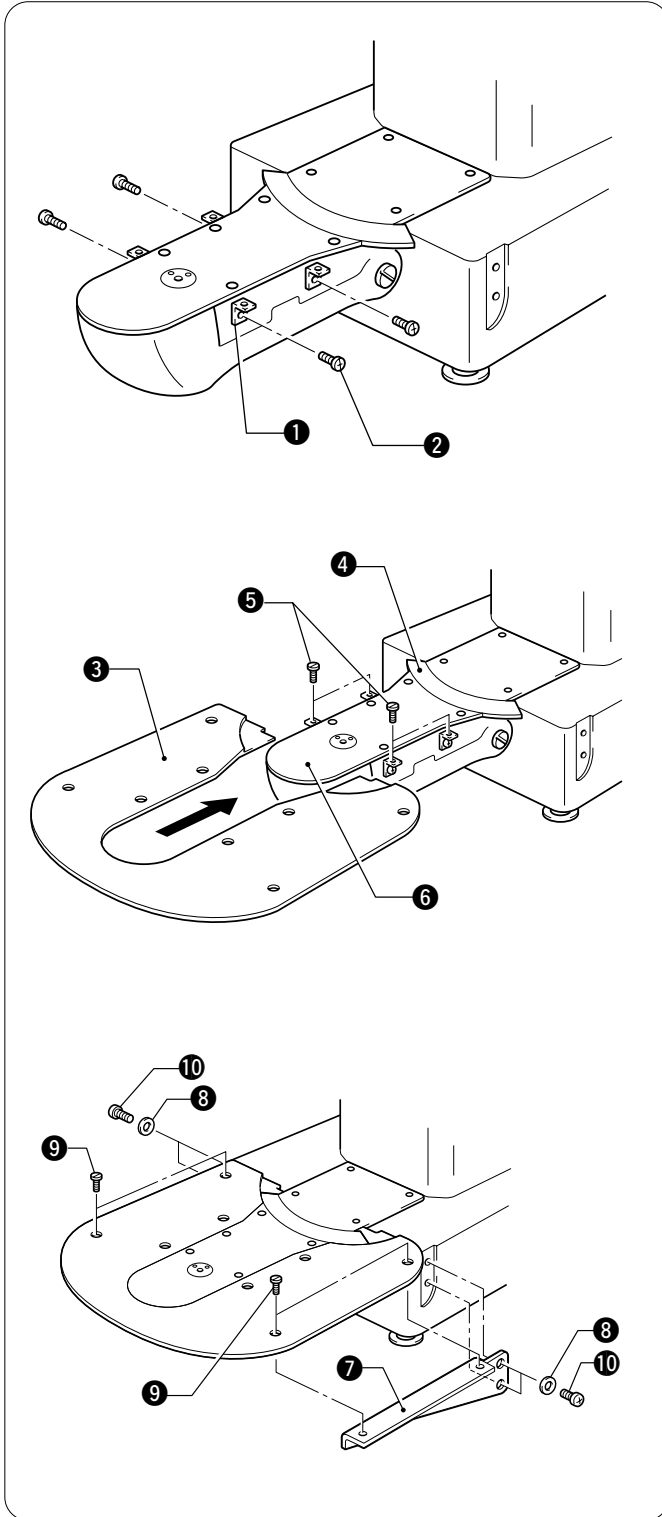

1. Install the four needle sub plate supports **1** with the four screws **2**.

2. Insert the needle sub plate **3** from the front of the machine so that it is level.

NOTE:

Insert the needle sub plate **3** so that the X feed lever cap **4** sits on top of the needle sub plate **3**.

3. Install the needle sub plate **3** with the four screws **5**.

4. Loosen the screws **2** and make fine adjustments to the height of the needle sub plate **3** so that it is at the same height as the needle plate **6**.

5. Provisionally secure the two auxiliary plate supports **7** with the washers **8** and the screws **9** and **10**, and then firmly tighten the screws **9** and **10** in that order.

3-21. Installing the eye guard

CAUTION

Attach all safety devices before using the sewing machine.
If the machine is used without these devices attached, injury may result.

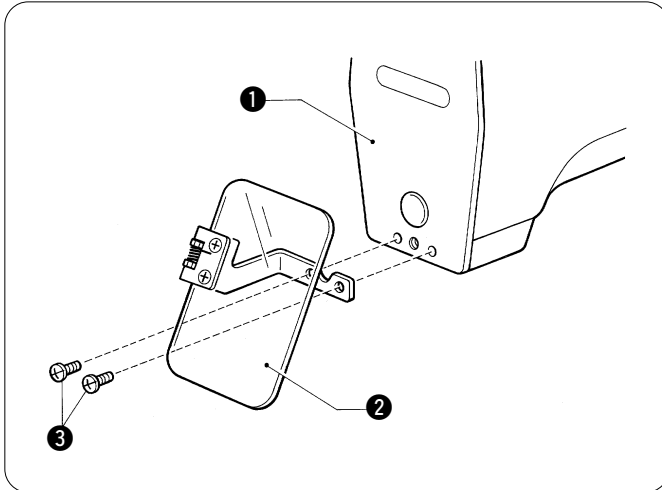

Install the eye guard assy **2** to the face plate **1** with the two screws **3**.

4. LUBRICATION

⚠ CAUTION

- ⚠ Turn off the power switch before starting lubricating, otherwise the machine may operate if the foot switch is depressed by mistake, which could result in injury.
- ⊘ Be sure to wear protective goggles and gloves when handling the lubricating oil and grease, so that they do not get into your eyes or onto your skin, otherwise inflammation can result. Furthermore, do not drink the oil or eat the grease under any circumstances, as they can cause vomiting and diarrhoea. Keep the oil out of the reach of children.

- NOTE 1: Fill the machine with oil when the oil level is down to about one-third full in the oil sight glass. If oil is not added and the oil drops below this level, there is the danger that the machine may seize during operation.
- NOTE 2: Be sure to let the machine operate for a while after adding the oil.
- NOTE 3: If there is no more oil on the felt of the shuttle race base, problems with sewing may result, so add oil to the felt until it is slightly soaked.
- NOTE 4: Use only specified Brother oil (Nisseki Sewing Libe 10) for the machine oil.

4-1. Lubrication points

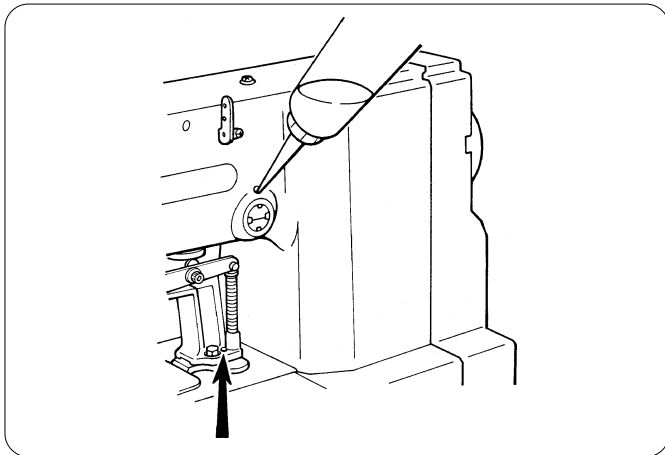

1. Fill the arm-side oil tank with oil.
* When setting up the sewing machine and when it hasn't been used for an extended period of time, be sure to add 2-3 drops of oil at the place indicated by the arrow.

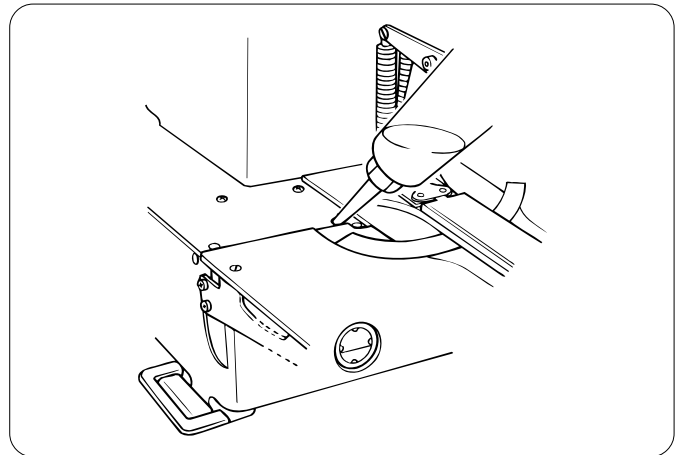

2. Fill the bed-side oil tank with oil

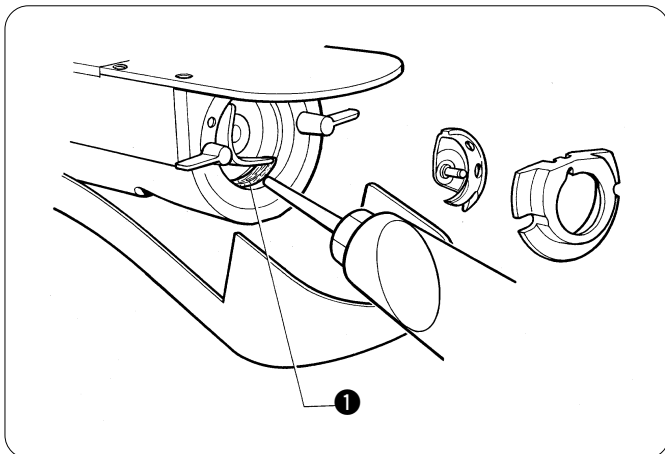

3. Add oil to the felt ① of the shuttle race base.
* When setting up the sewing machine and when it hasn't been used for an extended period of time, be sure to add 2-3 drops oil to the felt.

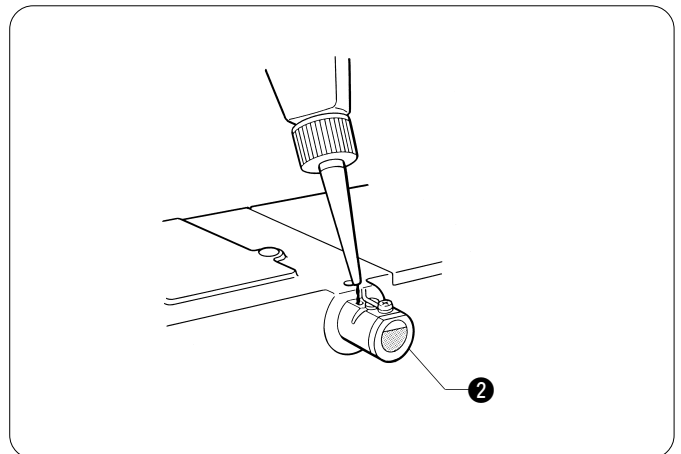

4. If using the liquid cooling tank ②, fill it with silicon oil (100 mm²/s).

5. OPERATION

5-1. Name and function of each operation panel item

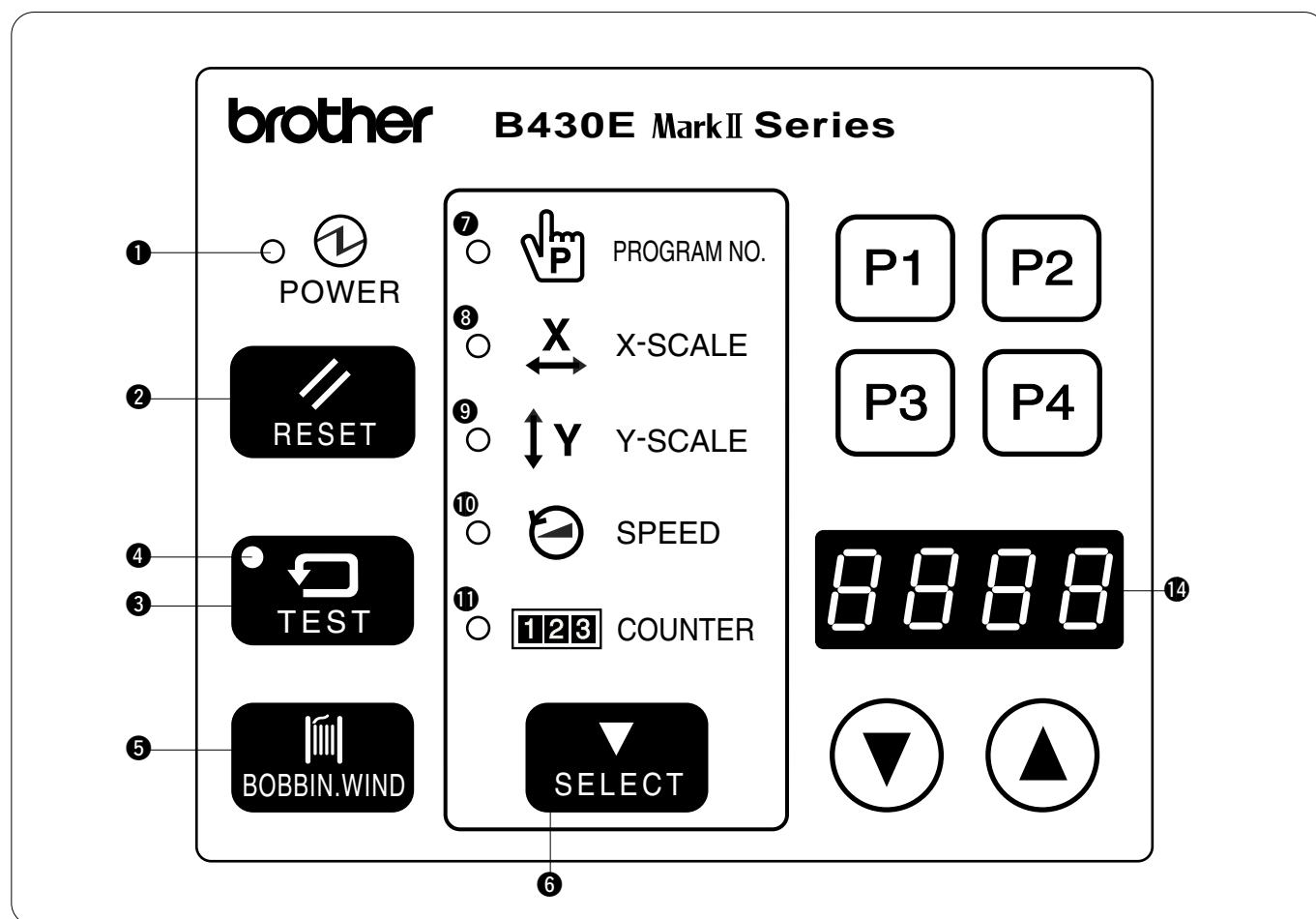

- 1** POWER indicator Illuminates when the power switch has been turned on.
- 2** RESET switch Press this switch to reset the machine when an error occurs.
- 3** TEST switch Use this switch when you want to operate only the feed mechanism in order to check a pattern.
- 4** TEST indicator Illuminates when the TEST switch has been pressed.
- 5** BOBBIN.WIND switch Press this switch to wind the lower thread.
- 6** SELECT switch Use this switch to select a menu (program number, X and Y feed, speed and counter). Each time the switch is pressed, one of the menu indicators (**7** to **11**) illuminates, and the setting for that menu item appears in the display **14**. The illuminated indicator changes as follows each time the switch is pressed.
- PROGRAM NO. indicator **7** → X-SCALE indicator **8** → Y-SCALE indicator **9** → SPEED indicator **10** → COUNTER indicator **11** →
- 7** PROGRAM NO. indicator Illuminates when the SELECT switch **6** is pressed to shown the program number setting.

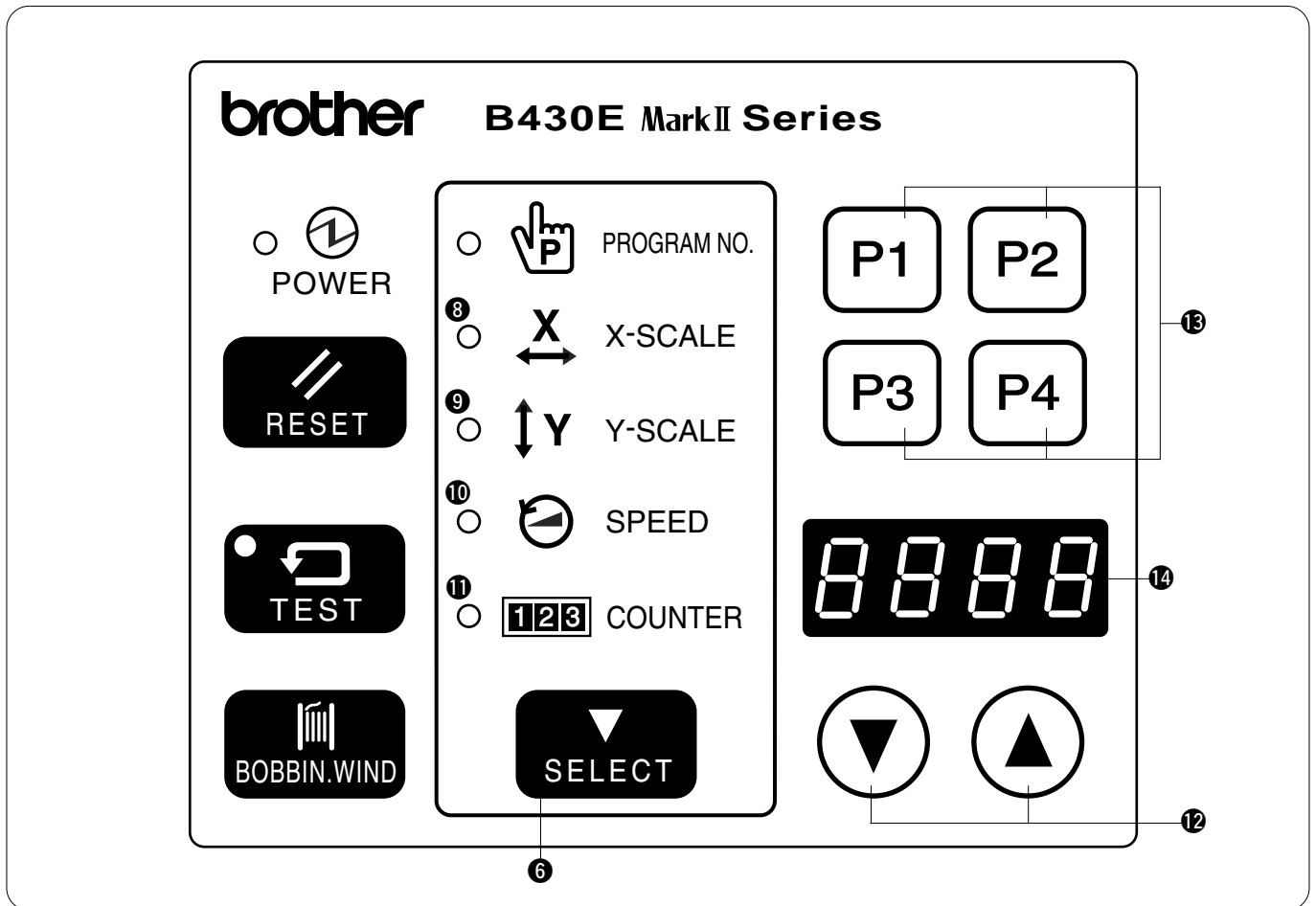

- ⑧ X-SCALE indicator Illuminates when the SELECT switch ⑥ is pressed to shown the X-scale setting.
- ⑨ Y-SCALE indicator Illuminates when the SELECT switch ⑥ is pressed to shown the Y-scale setting.
- ⑩ SPEED indicator Illuminates when the SELECT switch ⑥ is pressed to shown the speed setting.
- ⑪ COUNTER indicator Illuminates when the SELECT switch ⑥ is pressed to show the bobbin thread or production counter setting.
- ⑫ DISPLAY SET switches Used to change the menu details which are displayed in the window ⑭.
- ⑬ User program switches Used to set and select user programs.
- ⑭ Display window This display window will indicate the current statu for the selected menu, error or memory switch.

5-2. Operating procedure

Preparation

Turn on the power switch.
(The POWER indicator ① will illuminate and the program number will flash in the display window ⑭.)

	Factory default	Variable range
Program No.	0 *1	100 - *2
X-scale (%)	100	20 - 200
Y-scale (%)	100	20 - 200
Speed (rpm)	2000	1,000 - 2,500

*1 For checking the origin points for X and Y feed

*2 Custom-made program

5-2-1. Setting the program number

- 1** Press the SELECT switch ⑥ until the PROGRAM NO. indicator illuminates.

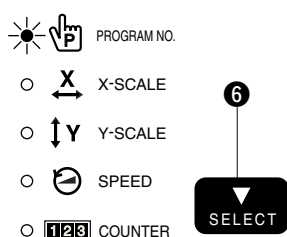

- 2** Press the DISPLAY SET switches ⑫ until the desired program number is flashing in the display window.

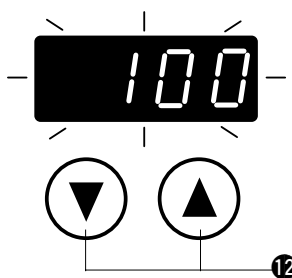

- 3** Depress the foot switch to the second step.

NOTE: For two-pedal foot switch, depress the work clamp switch to lower the work clamp, before depressing the start switch.

* The display will stop flashing and illuminates steadily, and the feed mechanism will move to the sewing start position.

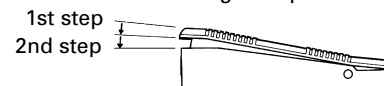

This completes the setting of the program number.

5-2-2. Setting the X-scale and Y-scale

- 1** Press the SELECT switch ⑥ until the X-scale or Y-scale indicator illuminates.

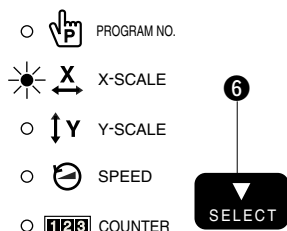

- 2** Press the DISPLAY SET switches ⑫ until the desired scale setting is flashing in the display window.
(The setting is displayed as a percentage.)

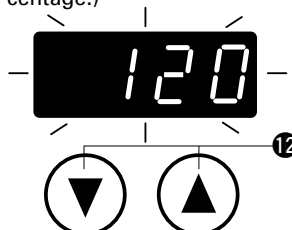

- 3** Depress the foot switch to the second step.

NOTE: For two-pedal foot switch, depress the work clamp switch to lower the work clamp, before depressing the start switch.

* The display will stop flashing and illuminates steadily, and the feed mechanism will move to the sewing start position.

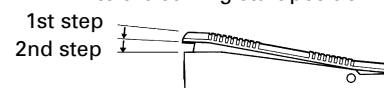

This completes the setting of the X-scale or Y-scale.

5-2-3. Setting the sewing speed

- 1** Press the SELECT switch ⑥ until the SPEED indicator illuminates.

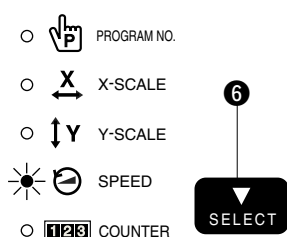

- 2** Press the DISPLAY SET switches ⑫ until the desired speed setting is flashing in the display window.

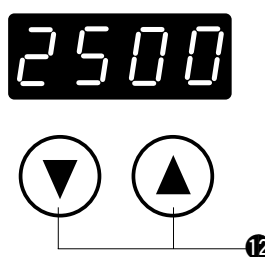

NOTE:

* Be sure to check the sewing pattern (refer to page 25) after setting has been completed to make sure that the needle hole does not go out of the area circumscribed by the work clamp.

* The needle racking width for backtack stitches (with stitch widths of 1 mm or less) is not enlarged or reduced. If this results in problems, set memo-0d to "ON".

5-3. Operating the foot switch

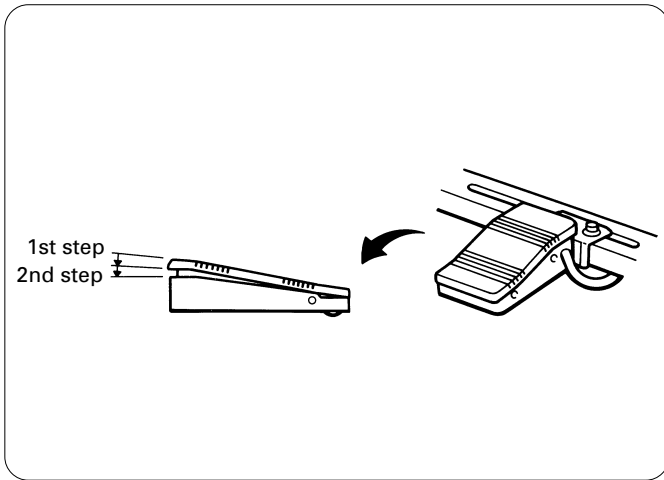

■ **Single-pedal foot switch (two steps)**

When the foot switch is depressed to step 1, the work clamp is lowered, and when it is depressed to step 2, sewing starts.

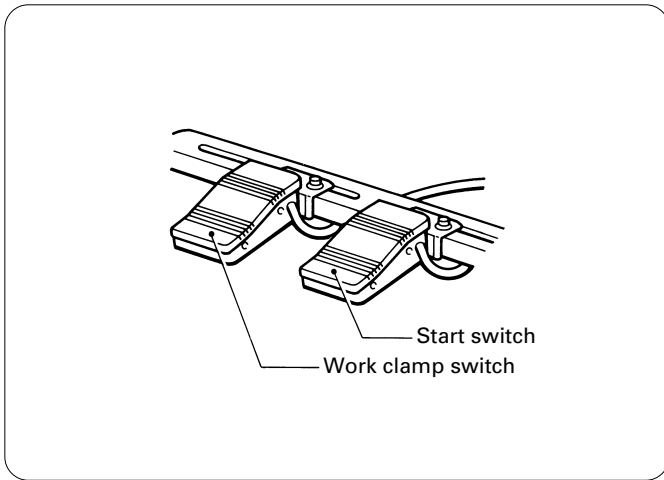

■ **Two-pedal foot switch (one step + one step)**

When the work clamp switch (left side) is depressed, the work clamp is lowered, and when the start switch (right side) is depressed, sewing starts.

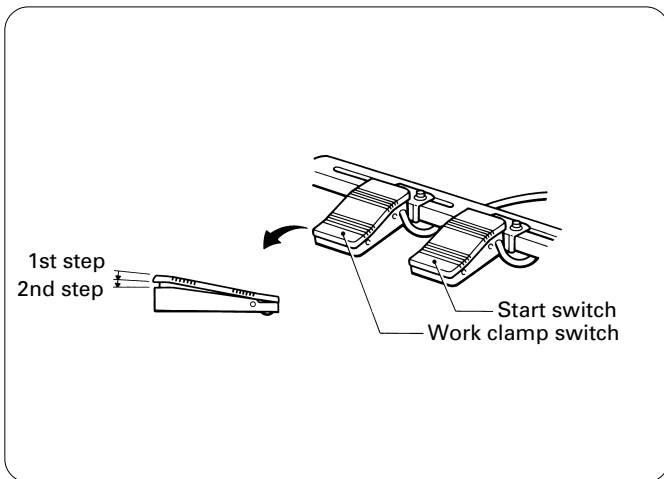

■ **Two-pedal foot switch (two steps + one step)**

* **For pneumatic**

When the work clamp switch (left side) is depressed to step 1, the work clamp on one side is lowered, and when it is pressed to step 2, the work clamps on both sides are lowered.

* The work clamp lowering pattern can be set to a variety of different patterns. (Refer to "14. SETTING THE WORK CLAMP MODE".

When the start switch (right side) is depressed, sewing starts.

5-4. Operating the emergency stop switch

If the emergency stop switch is pressed while normal sewing or test sewing is being carried out, the sewing machine will immediately stop operating.

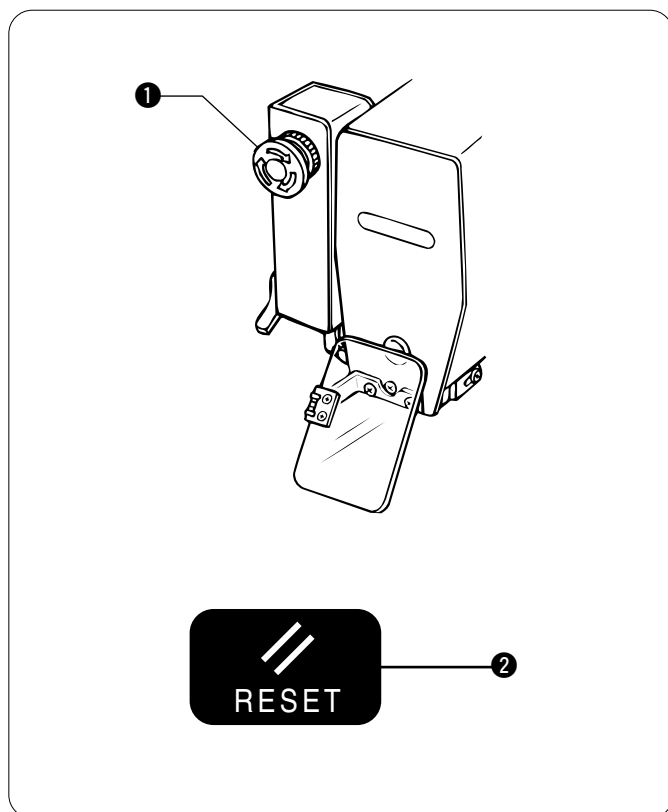

Canceling an emergency stop

1. Turn the emergency stop switch **1** clockwise and then pull it out to release the lock.
2. Press the RESET switch **2** on the control panel.
* The electronic alarm will stop sounding.
3. If not joining a new thread, press the RESET switch **2** once more so that the display panel flashes. Turn the pulley by hand to set the needle to the needle up stop position, and then continue with sewing.

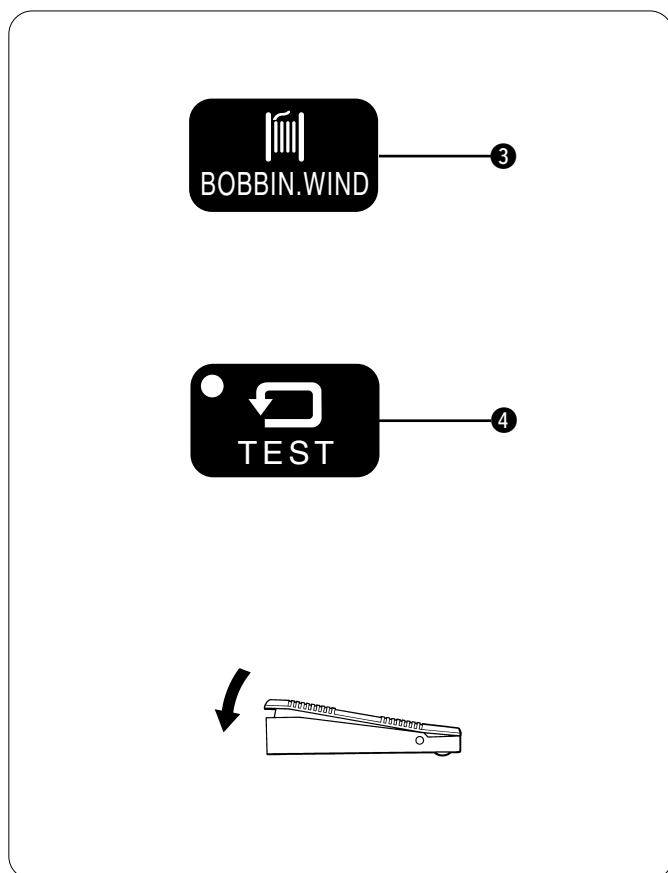

Continuing sewing from a stopping point

If the emergency stop switch was pressed because a thread breakage occurred or the lower thread ran out, sewing can be resumed from the point where the thread ended.

1. Turn the emergency stop switch **1** clockwise and then pull it out to release the lock.
2. Press the RESET switch **2** on the control panel.
* The electronic alarm will stop sounding.
3. Press the BOBBIN. WIND switch **3** to trim the thread.
4. Press the BOBBIN. WIND switch **3** once more.
* The work clamp will move backward one stitch at a time while this switch is being pressed. If the work clamp moves back too far, press the TEST switch **4** to move the work clamp forward. Press the TEST switch **4** once more when you would like the work clamp to stop.
5. Once the work clamp has returned to the desired position, depress the foot switch. The sewing machine will then resume sewing.

6. CHECKING THE SEWING PATTERN

■ When checking by operating only the feed mechanism

1. Turn on the power switch.
(The POWER indicator will illuminate and the program number will flash in the display window.)

2. Press the TEST switch.
(The TEST indicator will illuminate.)



3. Depress the foot switch to the second step.
 * For two-pedal foot switch, lower the work clamp before depressing the start switch (right side).
 (The feed mechanism will move to the sewing start position and the program number will stop flashing.)
 * This operation is only carried out the first time that a program has been selected or the size ratio has been changed.

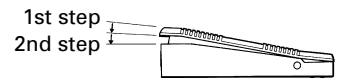

4. Depress the foot switch to the second step.
 Only the feed mechanism will move.
 [Check that the needle hole ① does not protrude past the frame of the work clamp ②.]
 * If you depress the foot switch again and keep it depressed after the feed mechanism has started to move, the feeding speed will increase.
 * If you would like to stop the feed while it is moving, press the TEST switch.

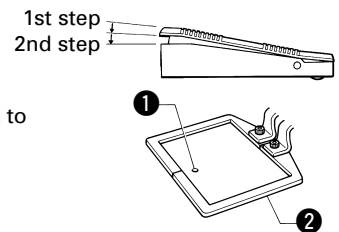

5. Press the TEST switch.
(The TEST indicator will switch off and the test mode will be cleared.)



6. Depress the foot switch.
 The work clamp will rise and the preparation for sewing will be completed.

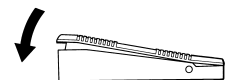

To ensure safety during use

You can prevent accidental changes being made to programs by setting DIP switches 7 and 8 to ON.

When DIP switch 7 is ON

... The sewing pattern cannot be enlarged.

When DIP switch 8 is ON

... The program number cannot be changed.

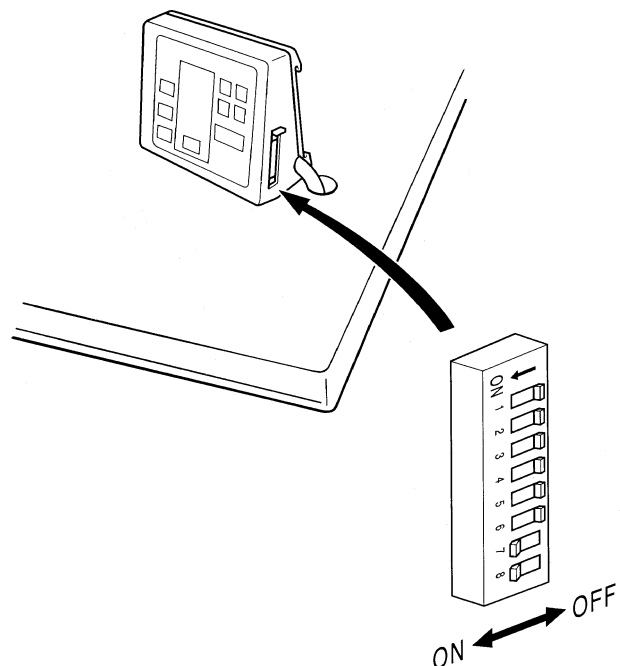

7. CORRECT USE

7-1. Selecting the needle and thread

Different needles and threads are used for different sewing applications.

Refer to the table at right for details on which needle and thread to select.

NOTE:

For inner clamping device, use only the DP × 17 needle.

Needle	Thread	Main application
DP × 5 #14	#80 - #50	Medium materials
DP × 17NY #19	#50 - #20	Heavy materials

7-2. Installing the needle

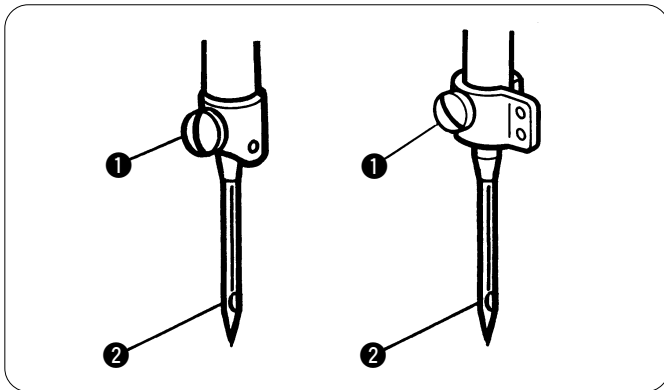

⚠ CAUTION

Turn off the power switch before installing the needle, otherwise the machine may operate if the foot switch is depressed by mistake and serious injury could result.

Loosen the set screw ❶, insert the needle ❷ as far as it will go so that the groove is facing toward you, and then tighten the set screw ❶.

7-3. Threading the upper thread

⚠ CAUTION

Turn off the power switch before threading the thread, otherwise the machine may operate if the foot switch is depressed by mistake and serious injury could result.

Thread the upper thread correctly as shown in the illustration below.

* If the tension release lever ❶ is raised in the direction of the arrow, it will be easier to open the tension disc ❷ and pull the thread through.

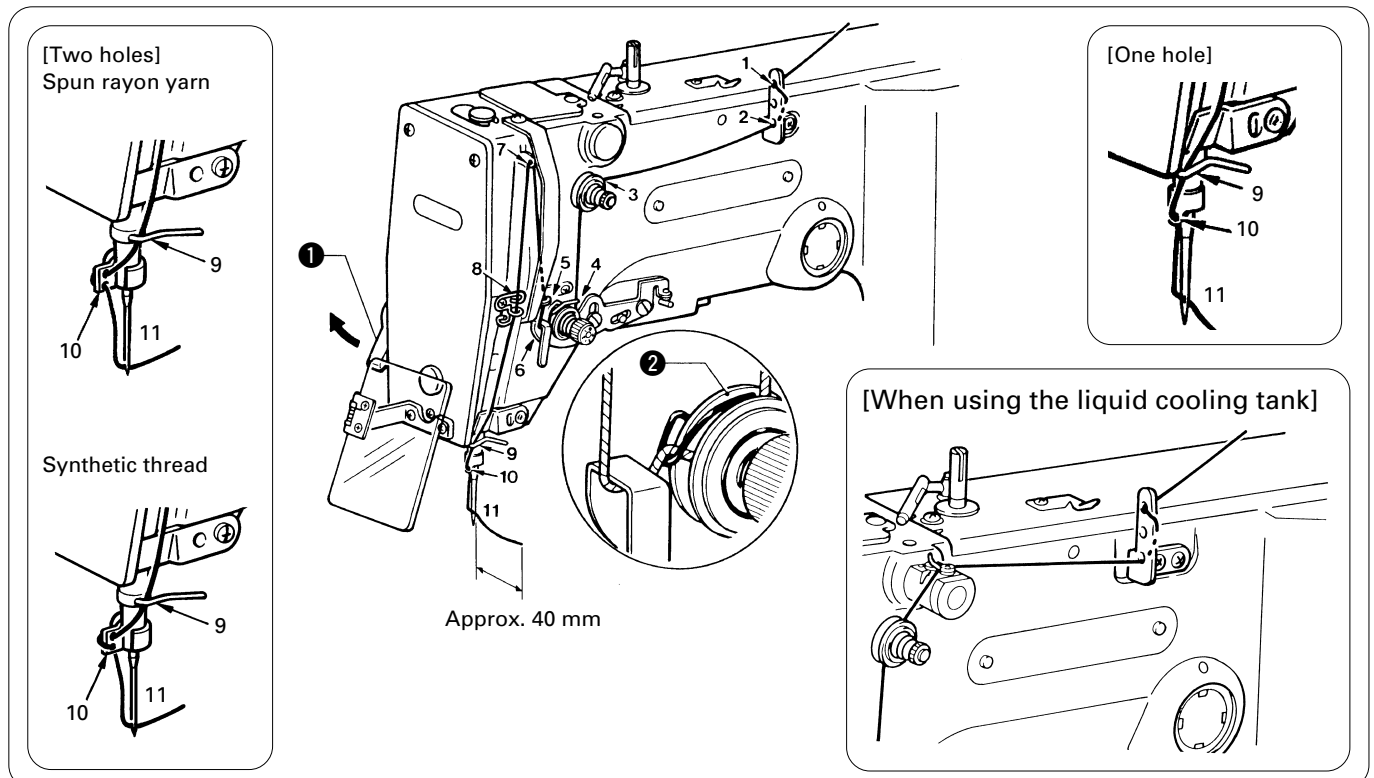

7. CORRECT USE

7-4. Winding the lower thread

CAUTION

 Do not touch or place anything against any of the moving parts while winding the lower thread, otherwise personal injury or damage to the machine may result.

1. Place the bobbin all the way onto the shaft.

2. Thread the thread as shown in the illustration at right, wind the thread around the bobbin several times in the direction of the arrow, and then press the bobbin presser **1**.

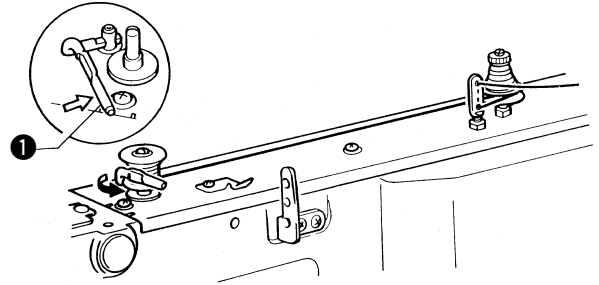

3. Turn on the power switch.
(The POWER indicator on the operation panel will illuminate.)

4. Check that the needle is not touching the presser foot, and then while pressing the BOBBIN. WIND switch **2**, depress the foot switch **3** to start the machine. Keep depressing the foot switch **3** until the lower thread stops being wound onto the bobbin.

[Release the BOBBIN. WIND switch **2** after the machine starts operating. If you release the foot switch before winding is completed, depress it once more while pressing and holding the BOBBIN. WIND switch **2**.]

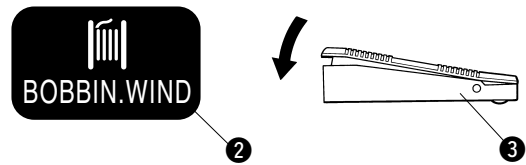

5. The bobbin presser **1** will automatically return to its original position after a set amount of thread (80 - 90% of the bobbin capacity) has been wound on.

6. Release the foot switch **3**.

7. Remove the bobbin, hook the thread onto the knife **4**, and then pull the bobbin in the direction of the arrow to cut the thread.

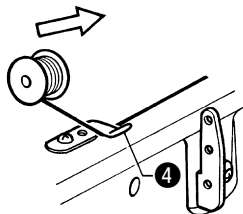

8. To wind more thread onto the bobbin, loosen the set screw **5** and pull the bobbin presser **1** outward.

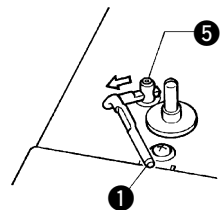

<<If the thread winds onto the bobbin unevenly>>
If the thread winds onto the bobbin unevenly, loosen the nut **1** and turn the bobbin winder thread tension stud **2** to adjust.

* If the thread winds on as shown in A, turn the bobbin winder thread tension stud **2** clockwise; if it winds on as shown in B, turn the bobbin winder thread tension stud **2** counterclockwise.

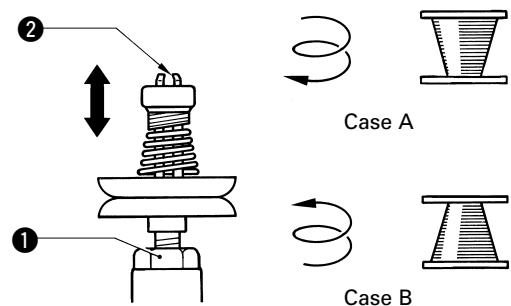

7-5. Replacing the bobbin case and threading the thread

 **CAUTION**

 Turn off the power switch before removing and replacing the bobbin case, otherwise the machine may operate if the foot switch is depressed by mistake and serious injury could result.

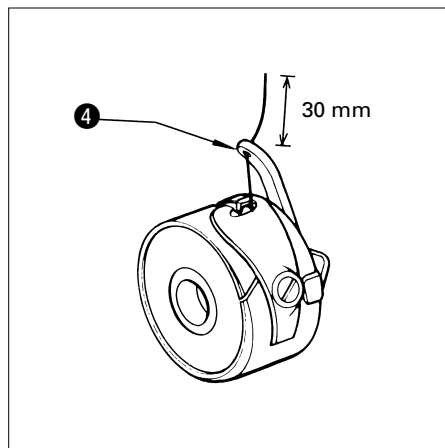
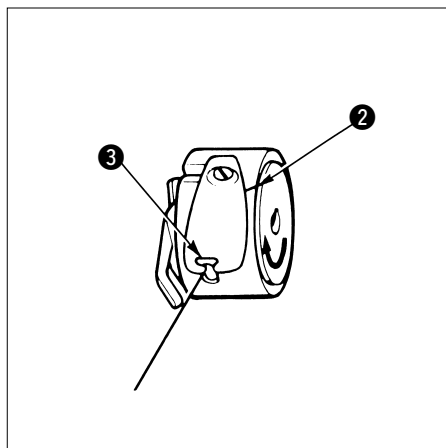
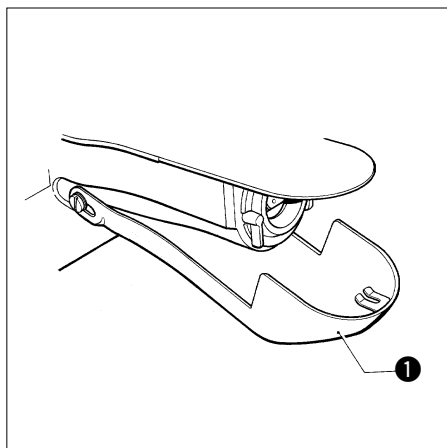

Pull the shuttle race cover ① toward you to open it.

Insert a new bobbin into the bobbin case, and then pass the thread through the slot ② and pull it out from the thread hole ③. Check that the bobbin turns in the direction of the arrow when the thread is pulled at this time.

Pass the thread through the lever thread hole ④, and then pull out approximately 30 mm of thread.

7-6. Sewing conditions and thread tension

Use	Medium materials		Heavy materials	
	Standard hook	Large hook	Standard hook	Large hook
Upper thread	#50 or equivalent	←	#30 or equivalent	←
Lower thread	#60 or equivalent	←	#50 or equivalent	←
Upper thread tension (N)	0.6 - 0.9	1.0 - 1.3	1.2 - 1.6	1.4 - 1.8
Lower thread tension (N)	0.2 - 0.3	←	0.2 - 0.3	←
Thread take-up spring height (mm)	6 - 8	←	6 - 8	←
Thread take-up spring tension (N)	0.15 - 0.35	←	0.4 - 0.6	←
Pre-tension (N)	0.1 - 0.3	←	0.3 - 0.5	←
Needle	DP × 5 #14	←	DP × 17NY #19	←

The sewing conditions given in the above table may need to be changed depending on the article being sewn.

7. CORRECT USE

7-6-1. Guide to maximum sewing speed

<Standard hook>

Use	Max. sewing speed (rpm)
8 layers of denim	2,500
12 layers of denim	2,300
Ordinary materials	2,500

NOTE:

The thread may break due to heat under some sewing conditions. If this happens, reduce the sewing speed, or use the liquid cooling tank (option).

<Large hook>

Use	Max. sewing speed (rpm)
8 layers of denim	2,500
Ordinary materials	2,500

7-6-2. Lower thread tension

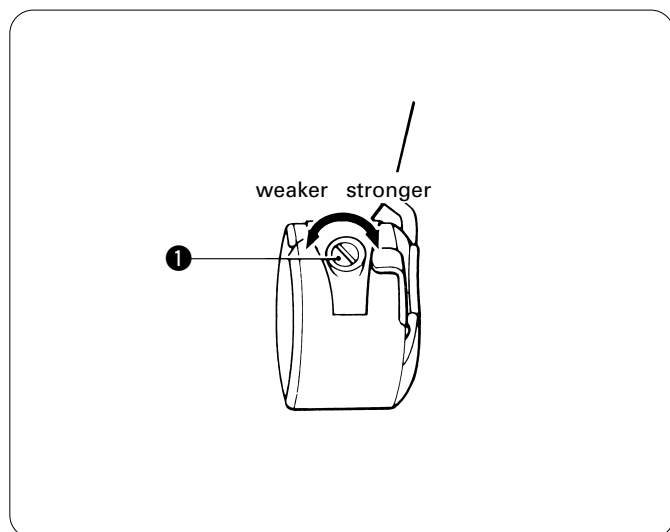

Adjust the thread tension to the weakest possible tension by turning the thread tension nut ① until the bobbin case will not drop by its own weight while the thread end coming out of the bobbin case is held.

7-6-3. Upper thread tension

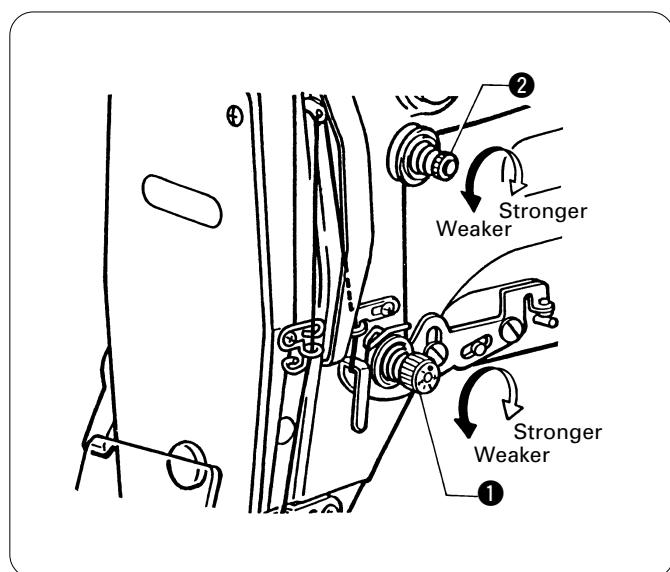

Turn the tension nut ① (main tension) to adjust the tension as appropriate for the material being sewn. Furthermore, turn the thread nut ② (sub-tension) to adjust the remaining length of upper thread to 35 - 40 mm, when the thread take-up lever is not used.

7-6-4. Thread take-up spring height

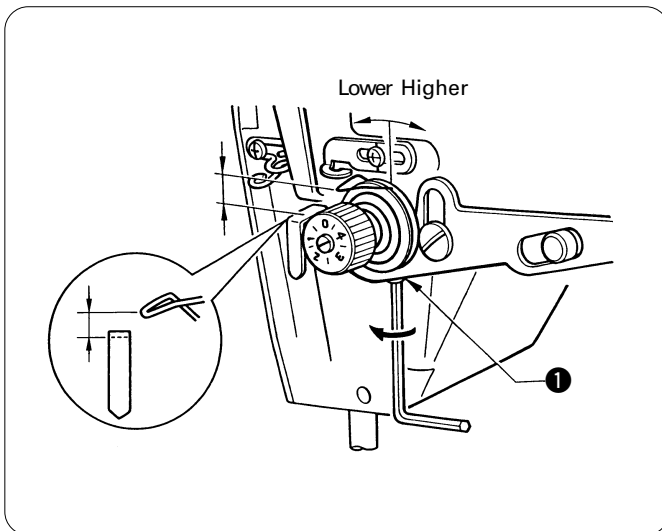

Loosen the set screw ① and turn the tensioner body to adjust the thread take-up spring height.

7-6-5. Thread take-up spring tension

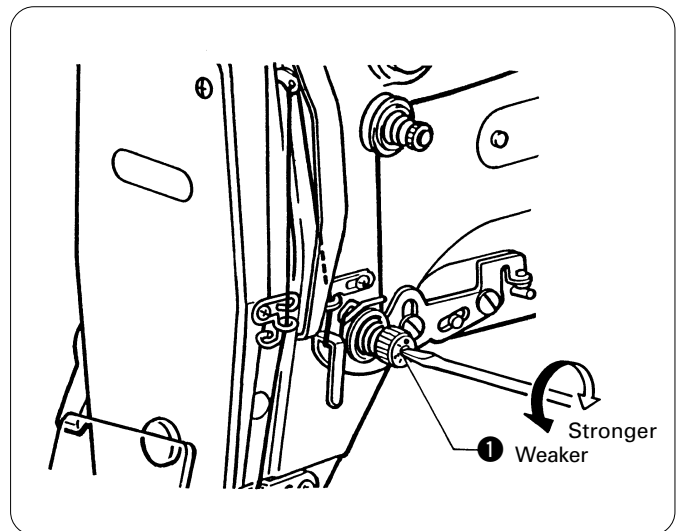

Turn the tension stud ① with a screwdriver.

7-6-6. Adjusting arm thread guide R

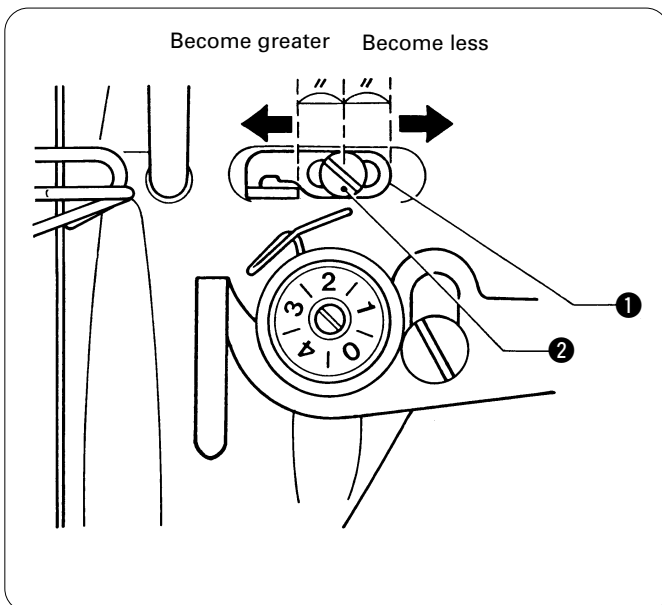

The standard position of arm thread guide R ① is the position where the screw ② is in the center of the adjustable range for arm thread guide R ①.

To adjust the position, loosen the screw ② and then move arm thread guide R ①.

- * When sewing thick material, move arm thread guide R ① to the left. (The thread take-up amount will become greater.)
- * When sewing thin material, move arm thread guide R ① to the right. (The thread take-up amount will become less.)

7-6-7. Thread take-up amount

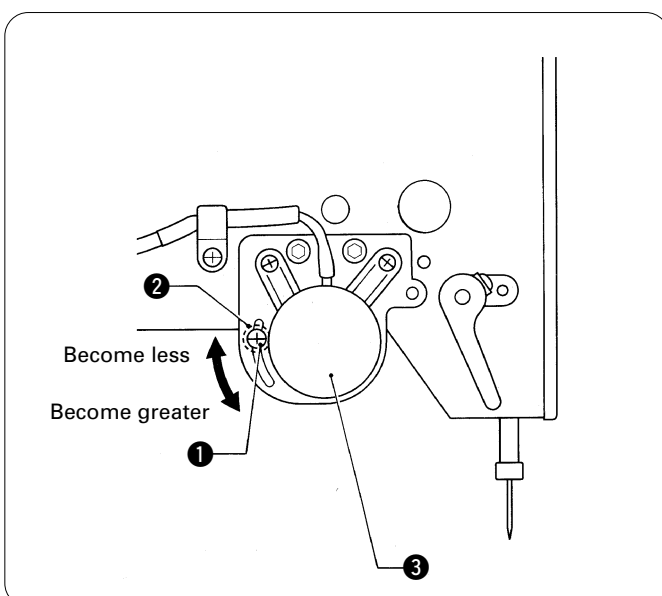

Loosen the screw ① and move the stopper (3.57 nut) ② to adjust the operating angle of the thread take-up solenoid ③.

- * To reduce the thread take-up amount, move the stopper ② upward.
- * To increase the thread take-up amount, move the stopper ② downward.

8. SEWING

⚠ CAUTION



Turn off the power switch at the following times, otherwise the machine may operate if the foot switch is depressed by mistake, which could result in injury.

- Threading
- When replacing the needle
- When not using the machine and when leaving the machine unattended.



Do not touch any of the moving parts or press any objects against the machine while sewing, as this may result in personal injury or damage to the machine.

Before starting sewing

- Check that the needle bar is at its highest position. Turn the machine pulley so that the index mark ❶ on the pulley is between the marks ❷ on the belt cover.
- * If the machine pulley stop position is incorrect, error "E-50" may be displayed, or the wiper may come into contact with the needle and break the tip of the needle.

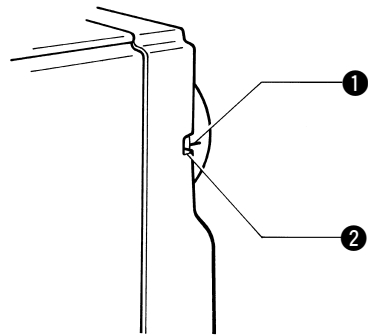

1. Turn on the power switch.
(The POWER indicator will illuminate and the program number will flash in the display.)

2. Depress the foot switch to the 2nd step.
* For two-pedal foot switch, depress the start switch (right side).
[The feed mechanism will move to the starting position and the work clamp will rise.
* Note that if the foot switch is pressed to the 2nd step while the display is illuminated, the machine will start operating.

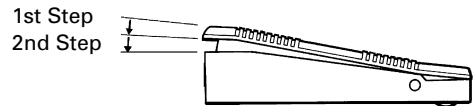

3. Place the material to be sewn under the work clamp ❸, and then depress the foot switch.
When the foot switch is pressed to the 1st step, the work clamp ❸ will lower.
If you would like to shift the position of the material, release the foot switch. The work clamp ❸ will then rise again.
When the foot switch is pressed to the 2nd step, the machine will start operating.
* For two-pedal foot switch, depress the work clamp switch (left side) to lower the work clamp before depressing the start switch (right side) in order to start the machine.

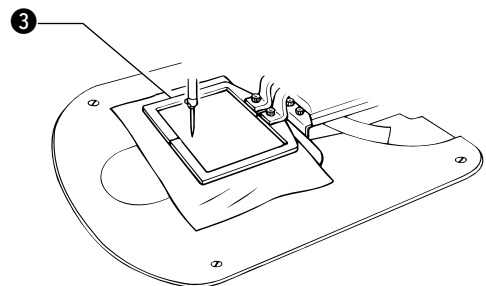

4. Once sewing is completed and the thread has been trimmed, feed will move automatically to the next starting point and the work clamp ❸ will rise.

9. MAINTENANCE AND INSPECTION

⚠ CAUTION

- ⚠ Turn off the power switch before carrying out cleaning, otherwise the machine may operate if the foot switch is pressed by mistake, which could result in injury.
- ⊘ Be sure to wear protective goggles and gloves when handling the lubricating oil and grease, so that they do not get into your eyes or onto your skin, otherwise inflammation can result. Furthermore, do not drink the oil or eat the grease under any circumstances, as they can cause vomiting and diarrhoea. Keep the oil out of the reach of children.

9-1. Cleaning the rotary hook

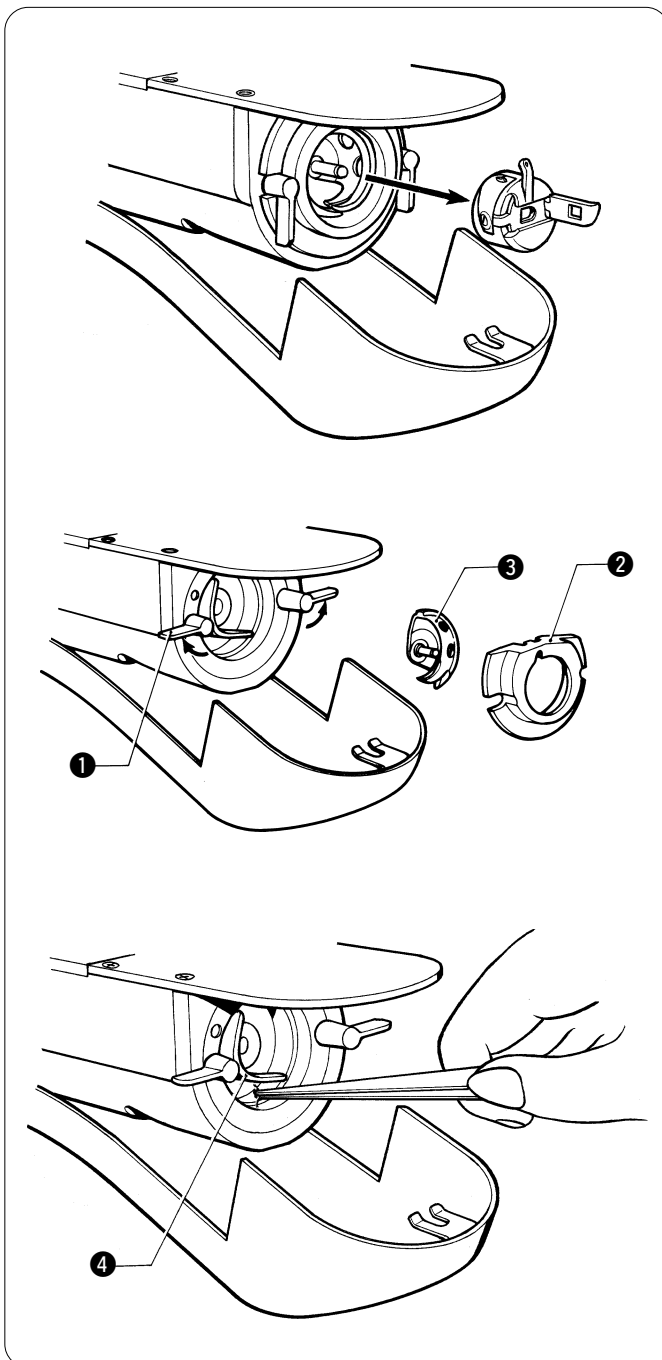

1. Pull the shuttle race cover toward you to open it, and then remove the bobbin case.
2. Open the setting claw ❶ in the direction indicated by the arrow, and then remove the shuttle race body ❷ and the shuttle hook ❸.
3. Clean all the dust and thread ends from around the driver ❹, the top of the rotary hook thread guide and the shuttle race.

9. MAINTENANCE AND INSPECTION

9-2. Lubrication

- NOTE1: Fill the machine with oil when the oil level is down to about one-third full in the oil sight glass.
If oil is not added and the oil drops below this level, there is the danger that the machine may seize during operation.
- NOTE2: Be sure to let the machine operate for a while after adding the oil.
- NOTE3: If there is no more oil on the felt of the shuttle race base, problems with sewing may result, so add oil to the felt until it is slightly soaked.
- NOTE4: Use only specified Brother oil (Nisseki Sewing Libe 10) for the machine oil.

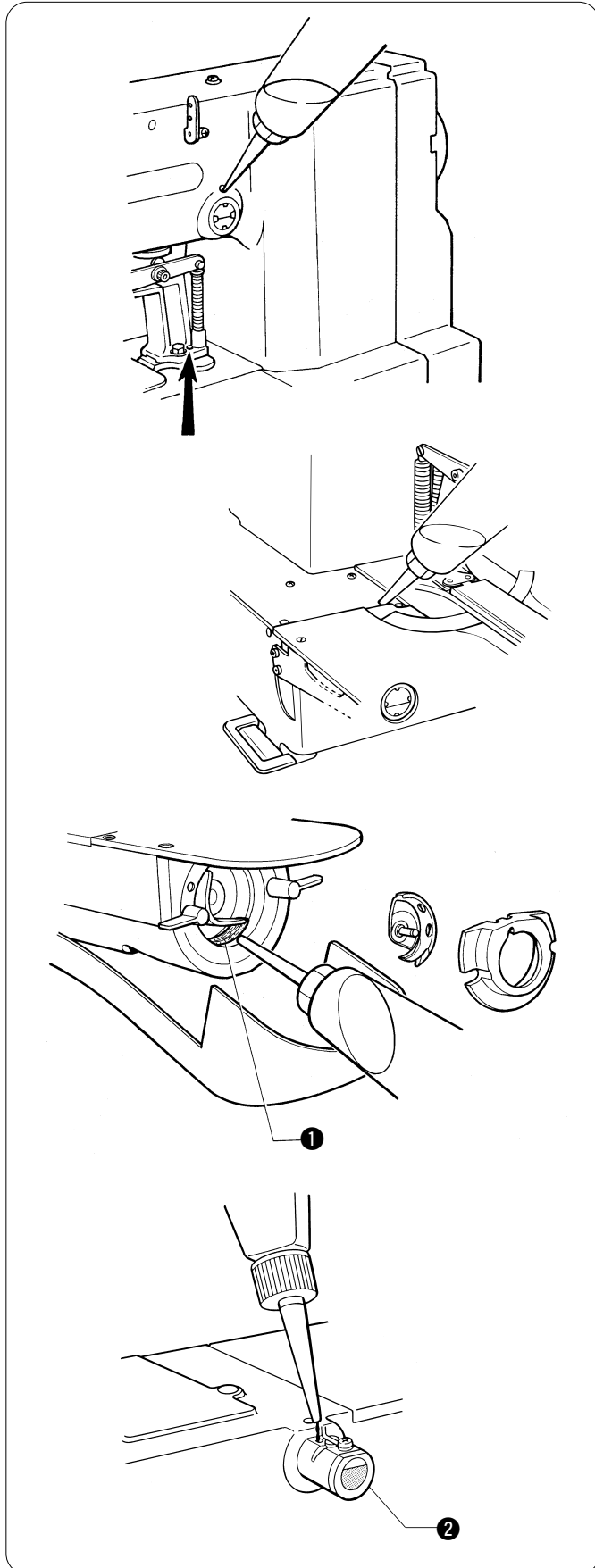

1. Fill the arm-side oil tank with oil.
* When setting up the sewing machine and when it hasn't been used for an extended period of time, be sure to add 2-3 drops of oil at the place indicated by the arrow.
2. Fill the bed-side oil tank with oil.
3. Add oil to the felt ① of the shuttle race base.
* When setting up the sewing machine and when it hasn't been used for an extended period of time, be sure to add 2-3 drops oil to the felt.
4. If using the liquid cooling tank ②, fill it with silicon oil (100 mm²/s).

9-3. Draining the oil

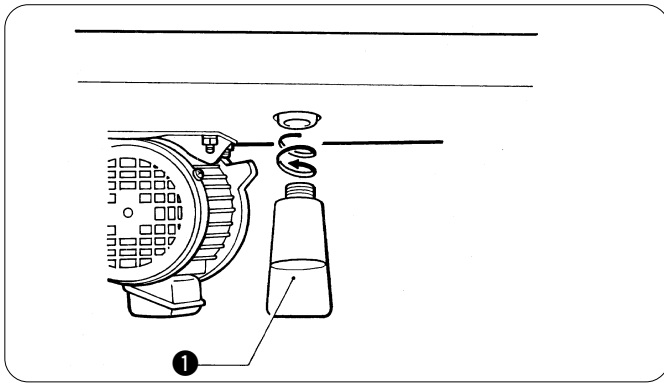

1. Remove and empty the waste oil container ❶ whenever it is full.
2. After emptying the waste oil container ❶, screw it back into its original position.

9-4. Cleaning the control box air inlet port

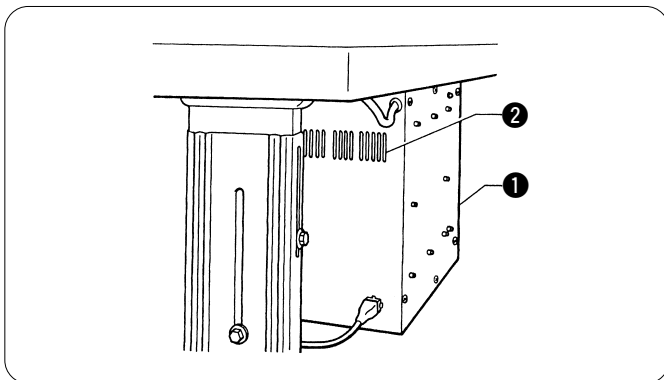

Use a vacuum cleaner to clean the filter in the air inlet port ❷ of the control box ❶ at least once a month.

* If the machine is used while the air inlet port is blocked, the inside of the control box will overheat. When this happens, the overheating error code ("E-d0") will be displayed and you will not be able to operate the sewing machine.

9-5. Cleaning the eye guard

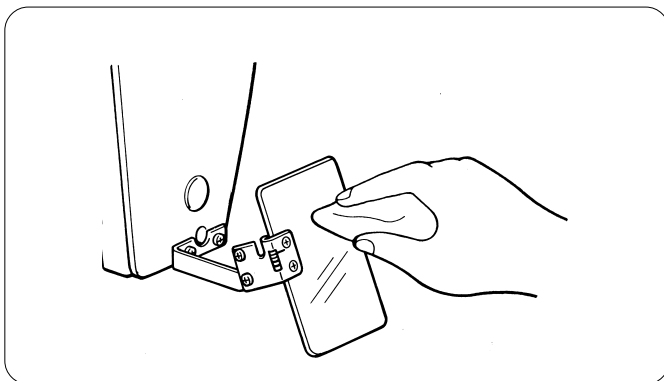

Wipe the eye guard clean with a soft cloth.

NOTE:

Do not use solvents such as kerosene or thinner to clean the eye guard.

9-6. Checking the needle

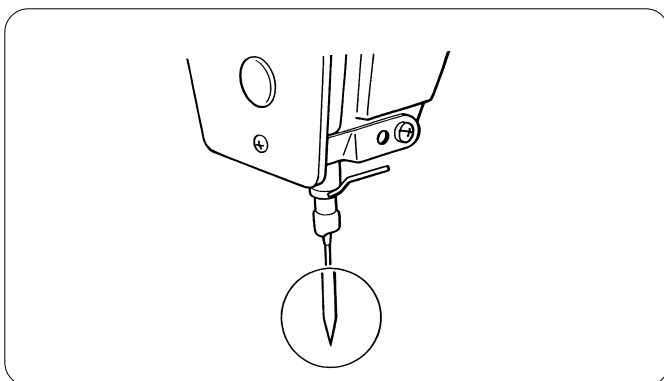

Always check that the tip of the needle is not broken and also the needle is not bent before starting sewing.

10. STANDARD ADJUSTMENTS

⚠ CAUTION

⊘ Maintenance and inspection of the sewing machine should only be carried out by a qualified technician.

❗ Ask your Brother dealer or a qualified electrician to carry out any maintenance and inspection of the electrical system.

⚡ Turn off the power switch and disconnect the power cord from the wall outlet at the following times, otherwise the machine may operate if the foot switch is depressed by mistake, which could result in injury.

- When carrying out inspection, adjustment and maintenance
- When replacing consumable parts such as the rotary hook and knife



Hold the machine head with both hands when tilting it back or returning it to its original position. Furthermore, after tilting back the machine head, do not push the face plate side or the pulley side from above, as this could cause the machine head to topple over, which may result in personal injury or damage to the machine.



If the power switch needs to be left on when carrying out some adjustment, be extremely careful to observe all safety precautions.



If any safety devices have been removed, be absolutely sure to re-install them to their original positions and check that they operate correctly before using the machine.

10-1. Adjusting the needle bar height

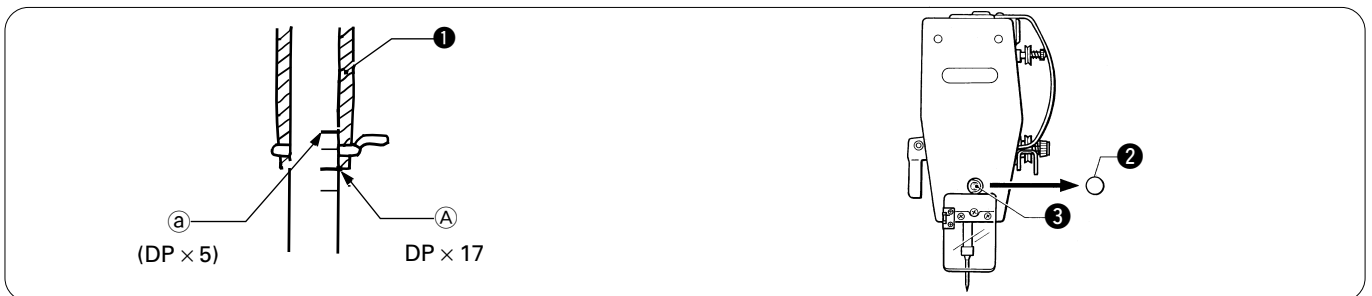

Turn the machine pulley to move the needle bar to the lowest position. Then remove the rubber plug ②, loosen the set screw ③ and then move the needle bar up or down to adjust so that the second reference line from the bottom of the needle (reference line A) is aligned with the lower edge of the needle bar bush ①.
* If using a DP × 5 needle, use the highest reference line (reference line a).

10-2. Adjusting the needle bar lift amount

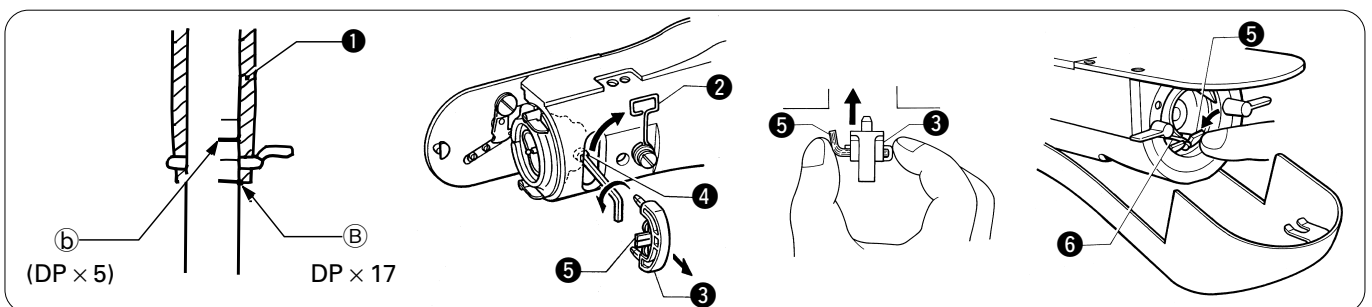

Adjust the needle bar lift amount as described below so that the tip of the rotary hook is aligned with the center of the needle when the machine pulley is turned to raise the needle bar from its lowest position until the lowest reference line on the needle (reference line B) is aligned with the lower edge of the needle bar bush ①.

* If using a DP × 5 needle, use the second reference line from the top of the needle (reference line b).

1. Open the support ② in the direction of the arrow, and remove the felt support ③.
2. Loosen the screw ④, and move the driver to adjust so that the tip of the rotary hook is aligned with the needle center line.

* When returning the felt support ③, place it as shown in the illustration so as not to clamp the felt ⑤, and then gently press the felt ⑤ and the wick ⑥ until they are at the same height as the rotary hook race.

* Return the support ② to its original position.

10-3. Adjusting the driver needle guard

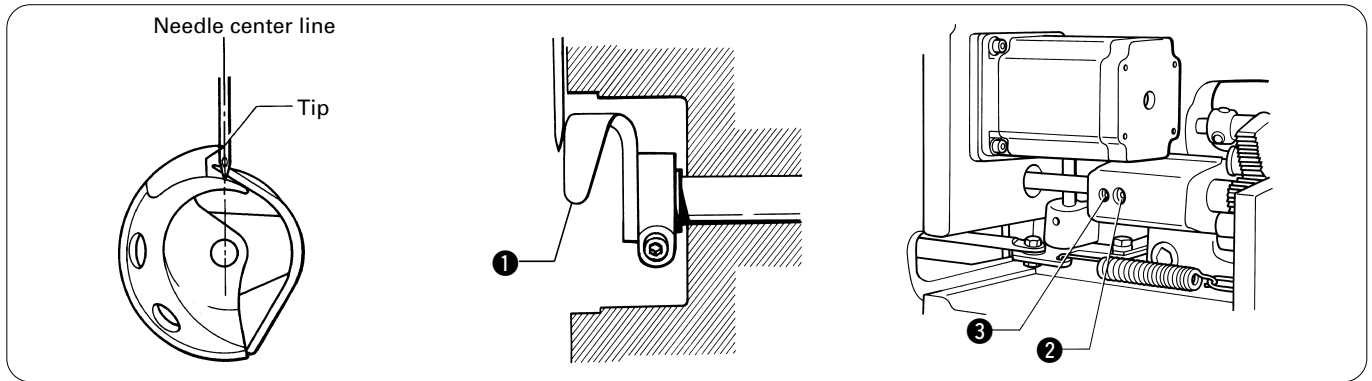

Turn the machine pulley to align the tip of the rotary hook with the needle center line. Then loosen the set screw ② and turn the eccentric shaft ③ to adjust so that the driver needle guard ① contacts the needle. If the needle contact pressure is too great, skipped stitches may occur. On the other hand, if the driver needle guard ① is not touching the needle, the tip of the inner rotary hook will obstruct the needle, resulting in an excessively high amount of friction.

10-4. Adjusting the needle clearance

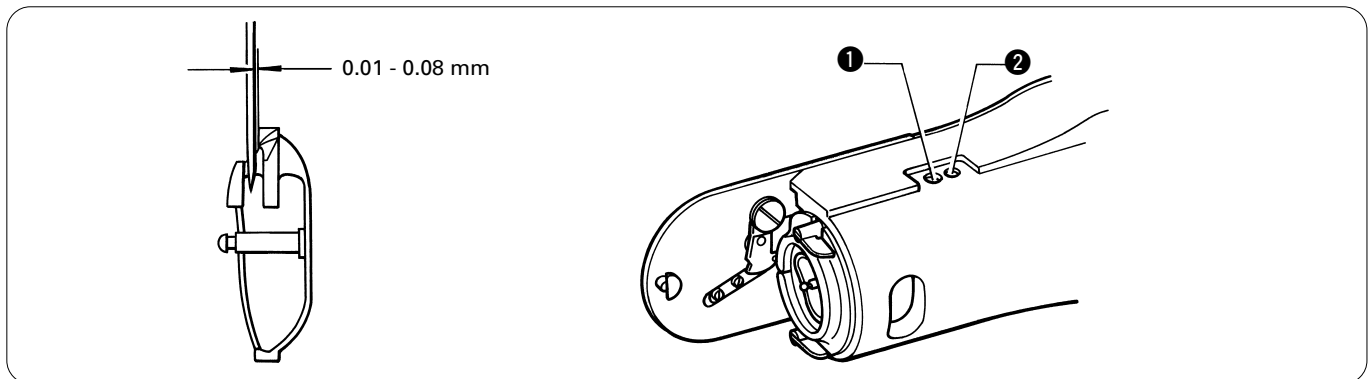

Turn the machine pulley to align the tip of the rotary hook with the needle center line. Then loosen the set screw ① and turn the eccentric shaft ② to adjust so that the clearance between the needle and the rotary hook is 0.01 - 0.08 mm.

10-5. Adjusting the shuttle race thread guide

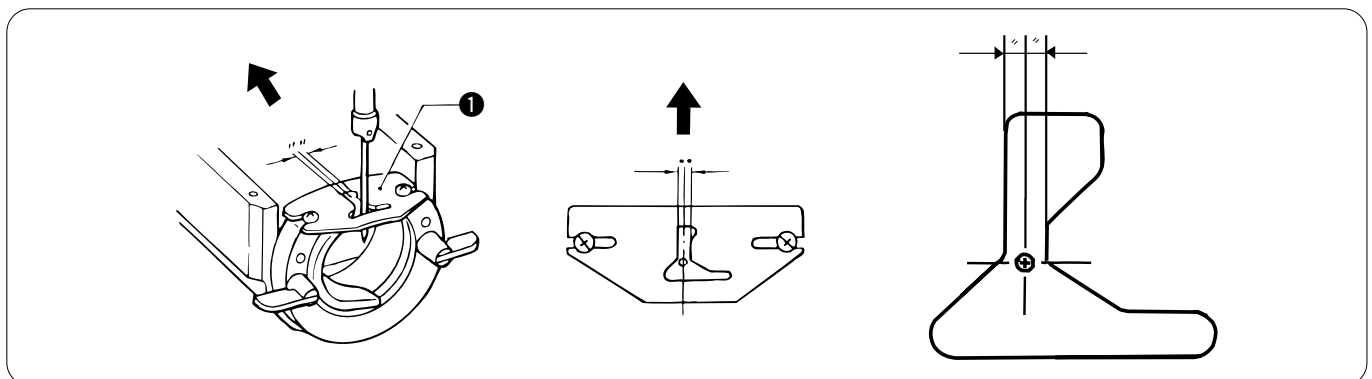

Install the shuttle race thread guide ① by pushing it in the direction of the arrow so that the needle groove is aligned with the center of the needle plate hole.

NOTE:

If the shuttle race thread guide is in the wrong position, thread breakages, soiled thread or catching of the thread may occur.

10. STANDARD ADJUSTMENTS

10-6. Adjusting the thread take-up amount

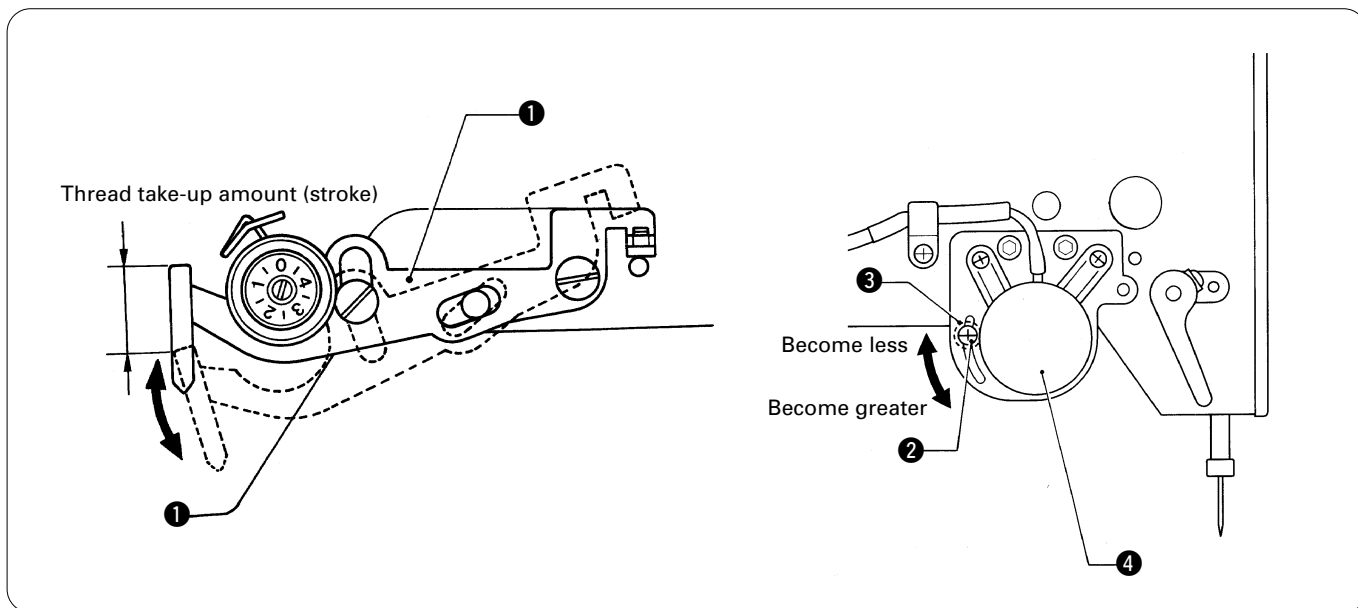

At the time of shipment from the factory, the thread take-up amount (stroke) of the thread take-up lever ① is set to the standard setting of 5 mm. You may need to adjust this setting depending on the sewing conditions to prevent the thread from pulling out at the sewing start.

[Adjustment method]

Loosen the screw ② and move the stopper (3.57 nut) ③ to adjust the operating angle of the thread take-up solenoid ④.

* To reduce the thread take-up amount, move the stopper ③ upward.

* To increase the thread take-up amount, move the stopper ③ downward.

NOTE:

Do not increase the stroke of the thread take-up lever any more than is necessary.

If the sub-thread tension is too high, the needle thread length may become too short and the thread may come out of the needle. Furthermore, if the sub-thread tension is too weak, the needle thread length may become too long and the underside of the article being sewn may become untidy.

10-7. Adjusting the movable knife

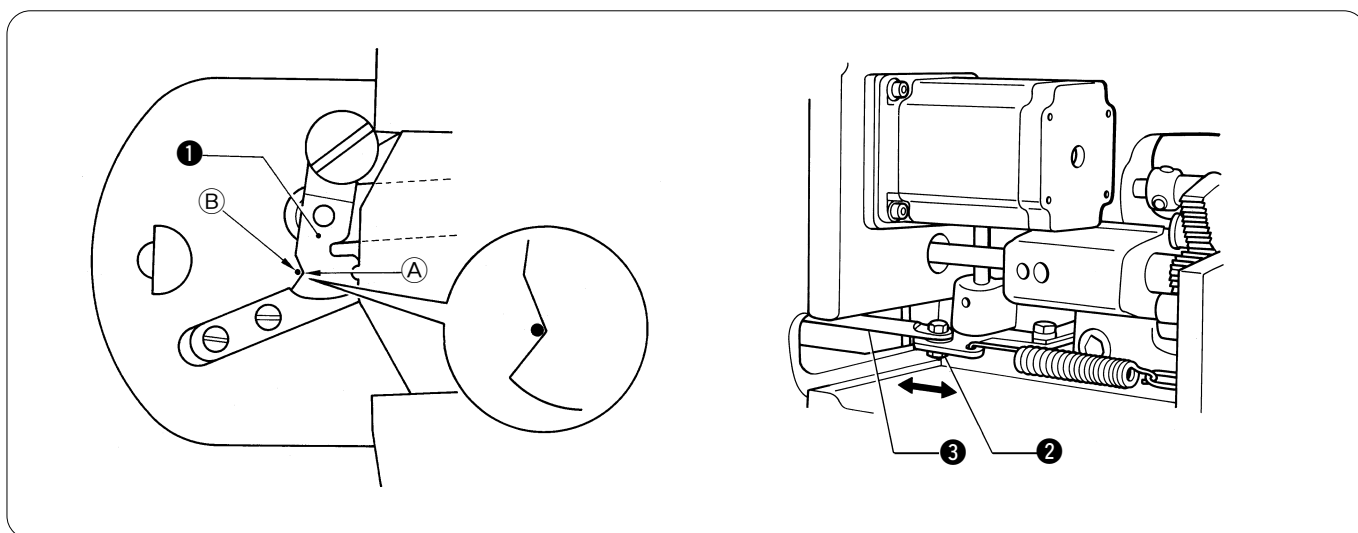

Loosen the nut ② and move the connecting rod lever ③ to the left or right to adjust so that the V section ① is aligned with the index mark ② on the needle plate when the sewing machine is in the stopped position and the movable knife ① is pushed to the machine pulley side so that there is no play.

10-7-1. Replacing the movable knife and fixed knife

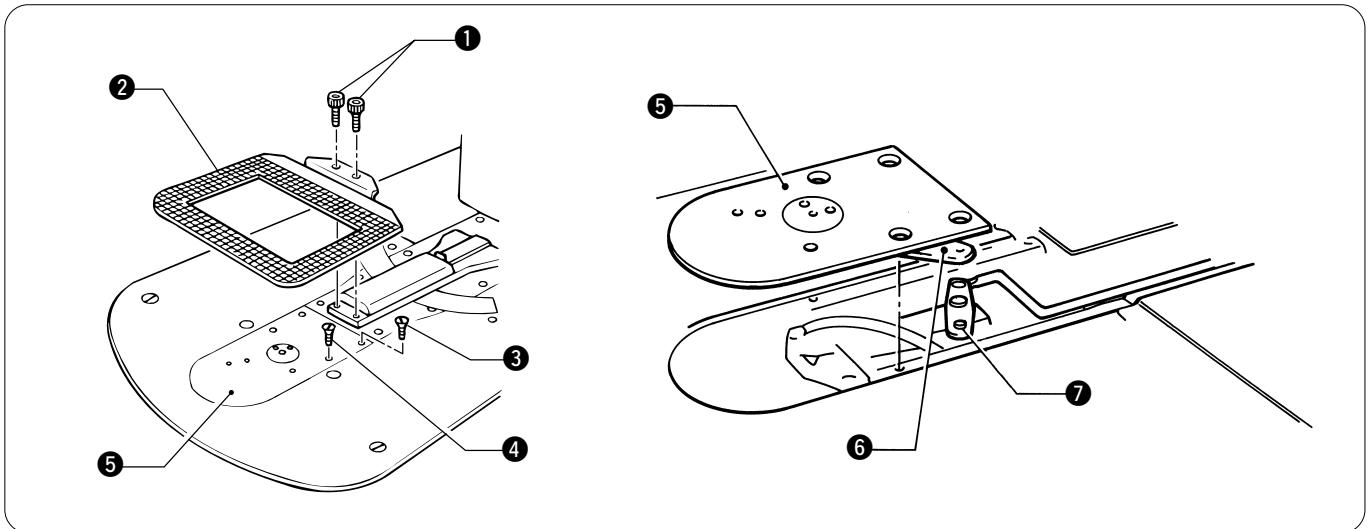

1. Open the large shuttle hook cover, remove the bolts ① and the feed plate ②.
2. Remove the two screws ③ and the two screws ④, and then remove the needle plate ⑤.
3. Remove the thread trimmer connecting rod ⑥ from the connecting rod lever pin ⑦.

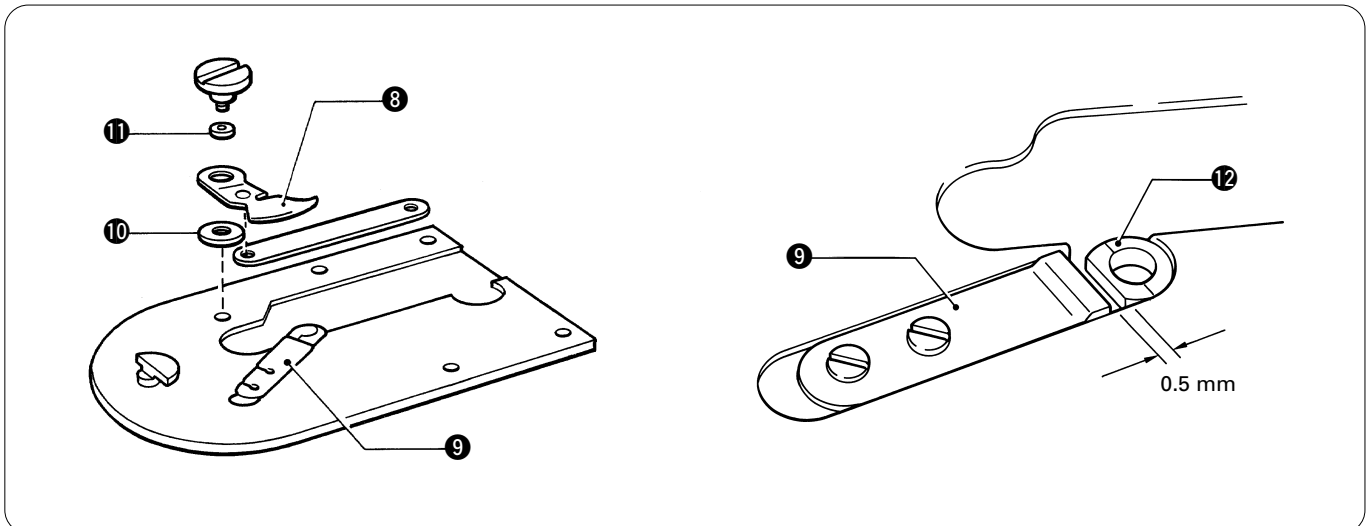

4. Remove the movable knife ⑧ and replace it with a new one. At this time, check that the movable knife ⑧ and the fixed knife ⑨ cut the thread cleanly. If necessary, adjust by using the appropriate movable knife washer ⑩ (supplied as accessories).
* Apply grease to the outside of the collar ⑪ at this time.
5. Install the fixed knife ⑨ at a distance of 0.5 mm from the needle hole plate ⑫.
6. Place the thread trimming connecting rod ⑥ onto the connecting rod lever pin ⑦, and then install to the needle plate ⑤.

10. STANDARD ADJUSTMENTS

10-7-2. Adjusting the engagement of the movable knife and fixed knife

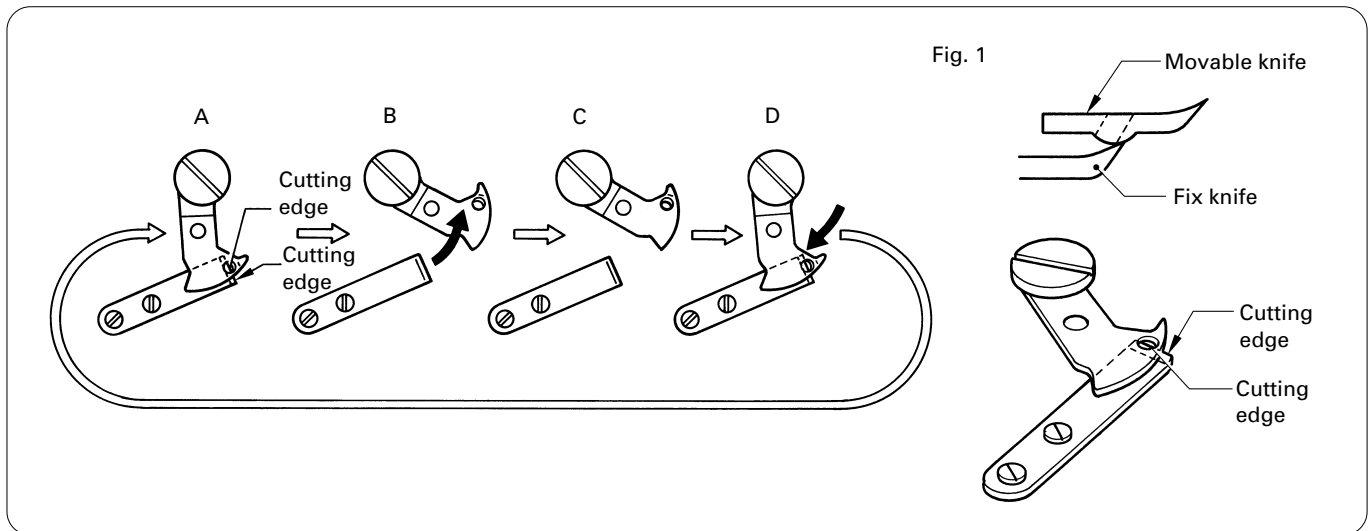

- A. After the movable knife and fixed knife are properly engaged, tighten the screw as shown in Fig.1.
 - B. Turn the movable knife (in the direction of the arrow) while the screw is still tightened.
 - C. Loosen the screw.
 - D. Turn the movable knife (in the direction of the arrow) while the screw is still loosened.
- Repeat above steps A, B, C and D four or five times to maintain the cutting performance of the knife.

10-8. Adjusting the work clamp lift amount

The maximum work clamp lift amount is 17 mm (25 mm for pneumatic, 17 mm for machines with inner clamping device) from the top of the needle plate. The lift amount is adjusted as shown in the table at the time of shipment.

Uses	Medium materials	Heavy materials
Lift amount	10 ⁺¹ ₀ mm	14 ⁺¹ ₀ mm

[Solenoid type]

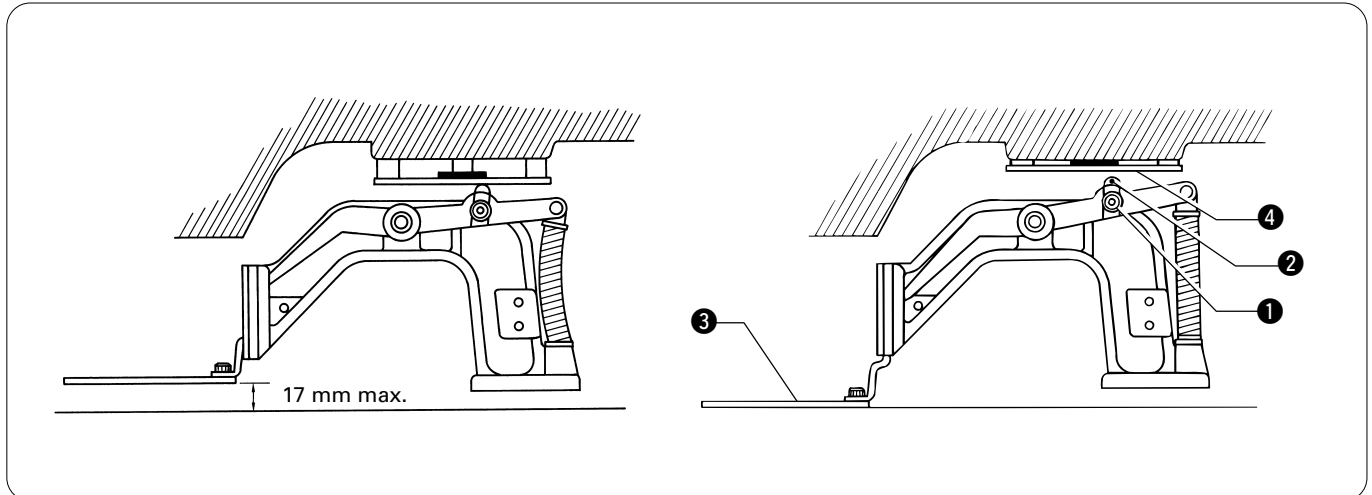

To adjust the work clamp lift amount, loosen the bolt ① and move the presser arm lever plate ② up or down.
 * If movement is sluggish when the work clamp ③ is being raised and lowered, it may not be possible to increase the work clamp ③ lift amount.

Apply grease to the bottom of the presser plate ④ to the top of the presser arm lever plate ② and to the sliding part of the work clamp ③ (grease is already applied at the time of shipment), and check that the movement becomes easier.

* If the work clamp ③ cannot be raised or lowered, error code "E-61" or "E-63" will be displayed.

* Check that there is a gap between the presser arm lever plate ② and the presser plate ④ when the presser foot is lowered.

[Pneumatic type]

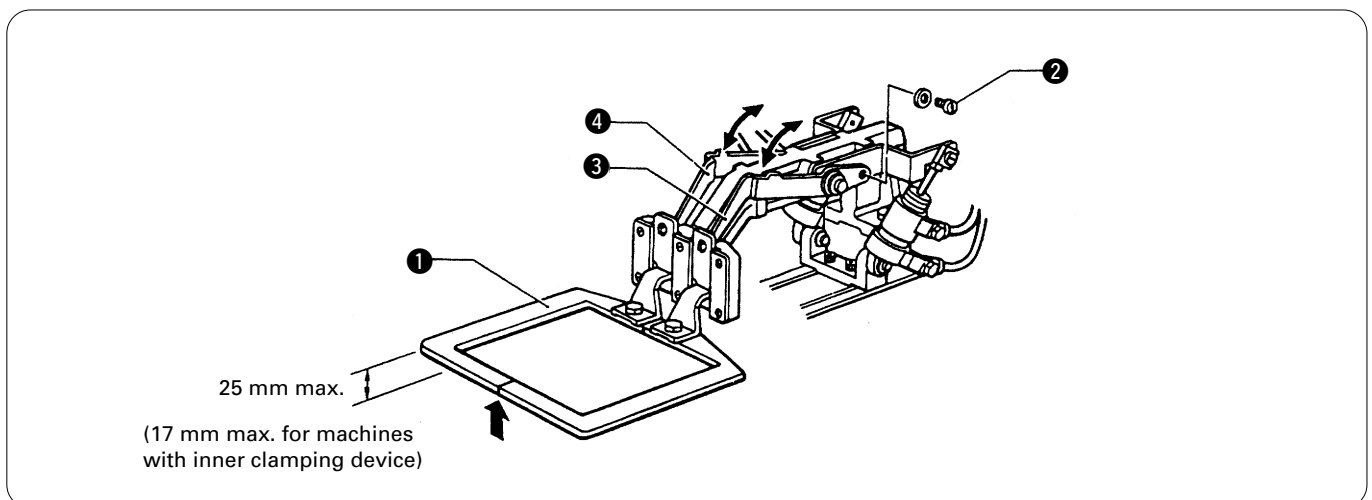

1. Raise the work clamp ① and loosen the screws ②.
2. Adjust the work clamp lift by moving the presser levers ③ and ④ up and down and then tighten the screws ②.

* If movement is sluggish when the work clamp ① is being raised and lowered, it may not be possible to increase the work clamp ① lift amount.

Apply grease to the sliding part of the work clamp ① (grease is already applied at the time of shipment), and check that the movement becomes easier.

10. STANDARD ADJUSTMENTS

10-9. Work clamp interchangeability

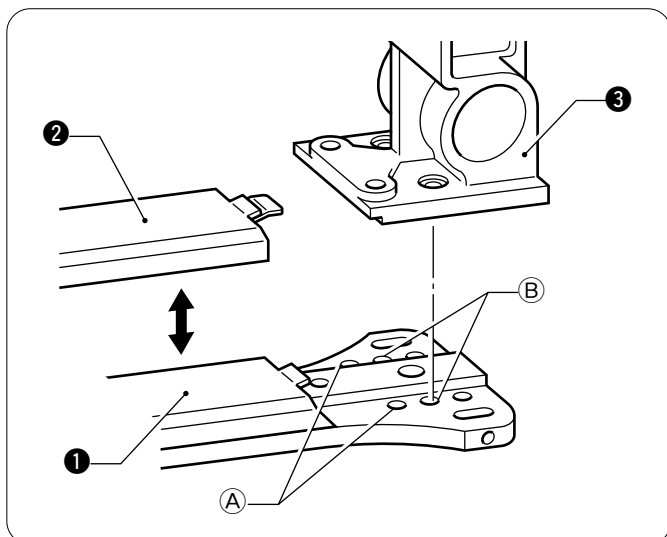

The BAS-311E work clamp can also be used with the B434E Mark II.

Replace the feed bar guide cover ① with the feed bar guide cover assembly, LL ② (optional).

Then, change the installation position for the presser arm assembly ③ from the standard installation position ① to installation position ②.

10-10. Adjusting the needle up stop position

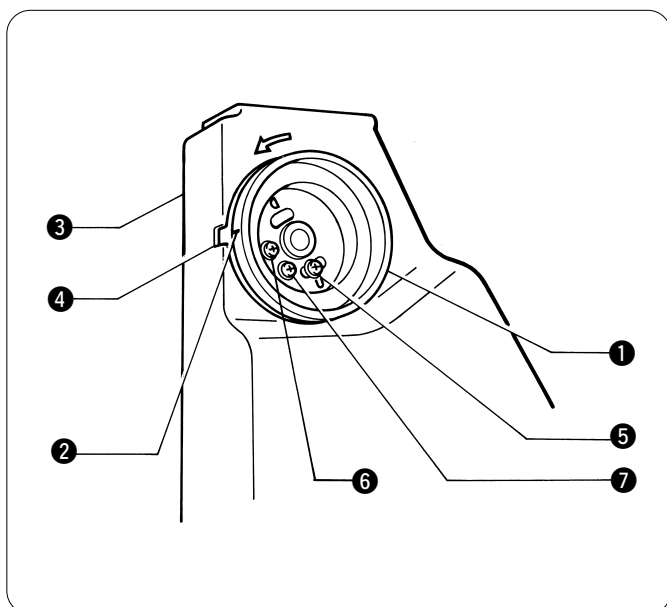

The needle up stop position is adjusted so that the index mark ② on the machine pulley ① is inside the mark ④ on the belt cover ③.

If adjustment is necessary, loosen the screw ⑤ at the "U" mark of the machine pulley ① and adjust the position of the machine pulley ①. The machine pulley ① stops later if it is turned clockwise, and it stops earlier if it is turned counterclockwise.

NOTE:

The screw ⑥ at the "D" mark is an adjusting screw for the needle down detection function and is adjusted to match the feed timing, so it should not be loosened.

The screw ⑦ is a screw for detecting the machine stop position, and should not be loosened.

* If the index mark ② is not inside the mark ④ when the sewing machine is started, error code "E-50" will be displayed. Turn the machine pulley to move the index mark ② to the correct position and then start the sewing machine.

10-11. Adjusting the thread wiper

[Solenoid type]

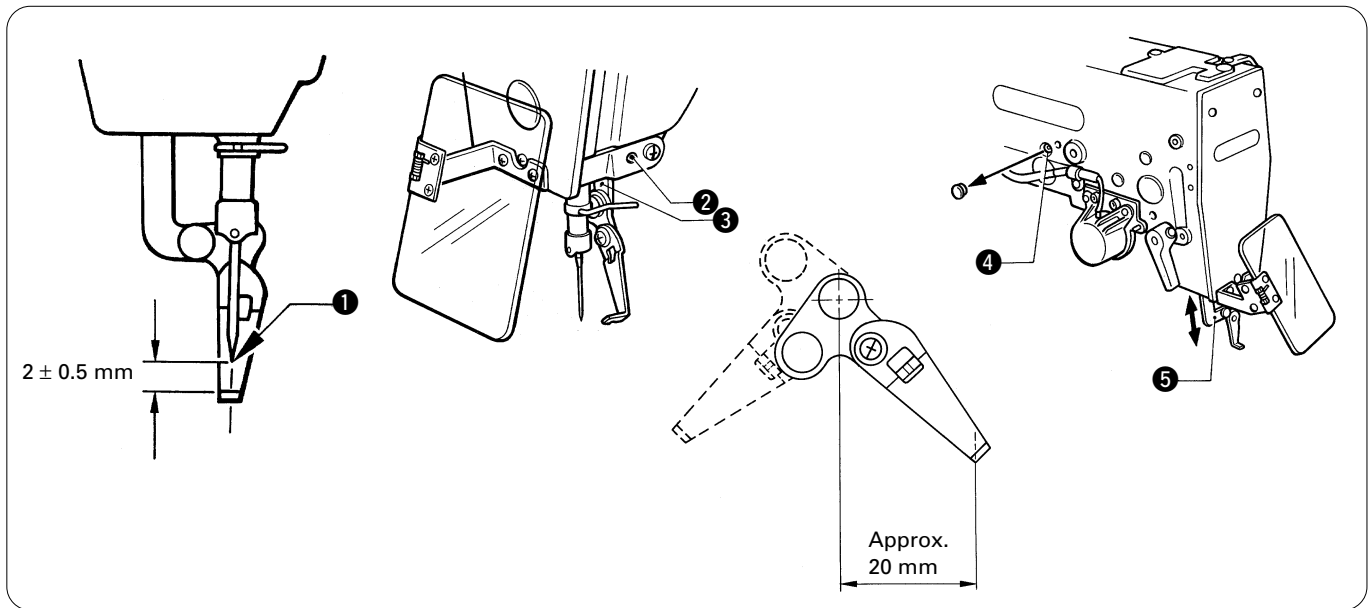

1. Loosen the set screw ② and move the wiper arm support ③ up or down to adjust so that the clearance between the top of the thread wiper and the needle point ① is 2 ± 0.5 mm when the thread wiper is aligned with the center of the needle.
 - * Before carrying out this adjustment, check that the needle bar is lowered 5 to 5.5 mm from the needle up stop position when the sewing machine stops.
2. Loosen the screw ④ and move the thread guide connecting plate ⑤ up or down so that the thread wiper is approximately 20 mm from the needle when it is at the standby position.

[Pneumatic type]

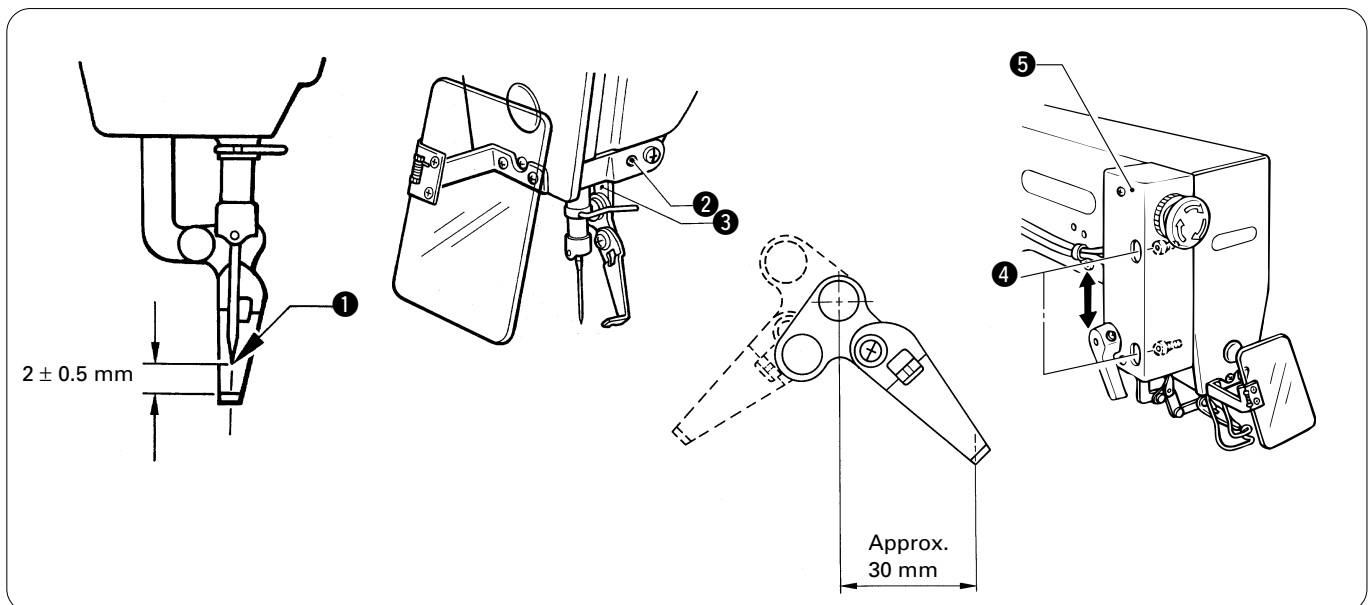

1. Loosen the set screw ② and move the wiper arm support ③ up or down to adjust so that the clearance between the top of the thread wiper and the needle point ① is 2 ± 0.5 mm when the thread wiper is aligned with the center of the needle.
 - * Before carrying out this adjustment, check that the needle bar is lowered 5 to 5.5 mm from the needle up stop position when the sewing machine stops.
2. Loosen the two bolts ④ and move the wiper solenoid cover ⑤ up or down so that the thread wiper is approximately 30 mm from the needle when it is at the standby position.

10. STANDARD ADJUSTMENTS

10-12. Checking the input sensor and DIP switch input

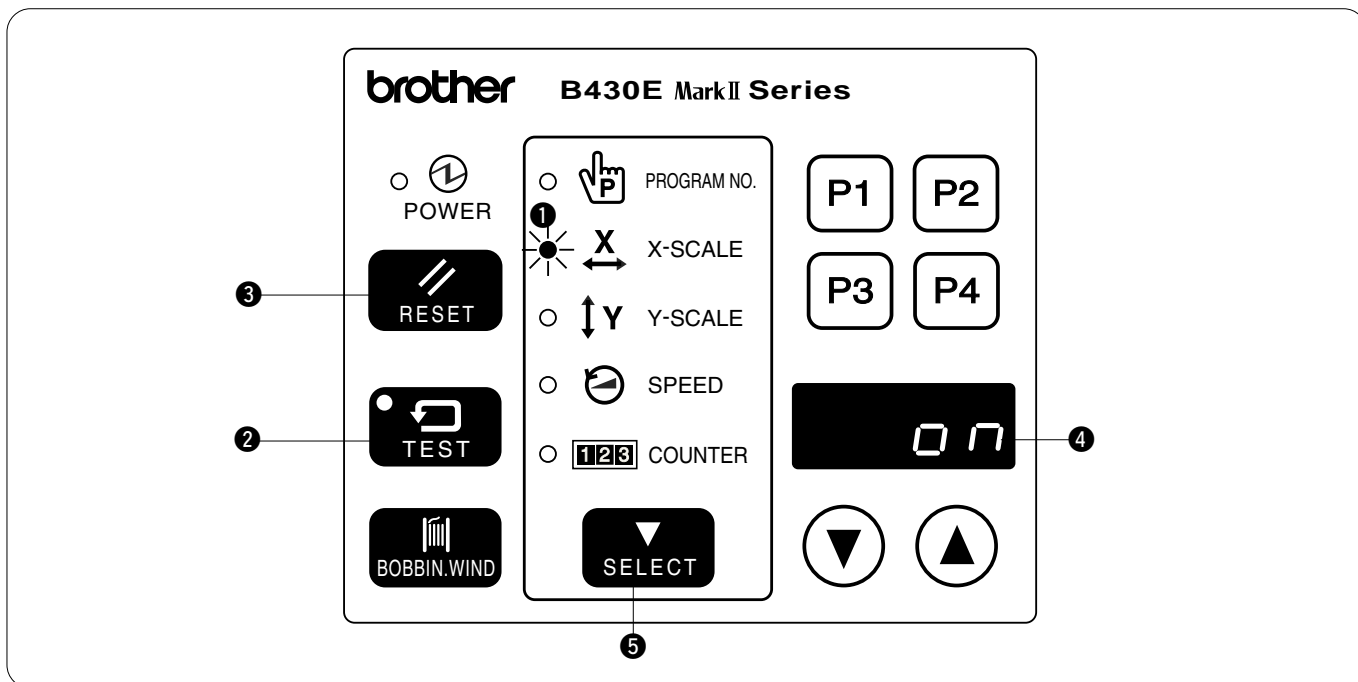

- When the X-SCALE indicator ① is illuminated and the RESET switch ③ is pressed while the TEST switch ② is being pressed, the state of the X home position signal will appear on the display window ④.
 - When sensor is ON
 - When sensor is OFF



- Each time the SELECT switch ⑤ is pressed, a different indicator will illuminate and the operating condition for the corresponding item will appear on the display window ④.
 - When X-SCALE indicator is illuminated X home position sensor (ON when home position detected)
 - When Y-SCALE indicator is illuminated Y home position sensor (ON when home position detected)
 - When SPEED indicator is illuminated Synchronizer (* 1)
 - When COUNTER indicator is illuminated ... Presser sensor (ON when presser is lowered) ... For solenoid specification

*1 The synchronizer display simultaneously displays the needle up signal (3rd digit), the 24-section signal (2nd digit) and the needle down signal (1st digit).

[H L L] "H" when the sensor is on, and "L" when the sensor is off

If the DIP switches at the side of the operation panel are changed at this time, the number of the DIP switch which was changed will be displayed in the 4th digit position of the display window ④ for about one second.

NOTE:

The DIP switch can be changed at this time without turning off the power so that you can check the DIP switch input. However, you should normally always turn off the power when changing DIP switch settings.

- Press the TEST switch ② again to return the display to the normal condition.

10-13. Checking the input voltage

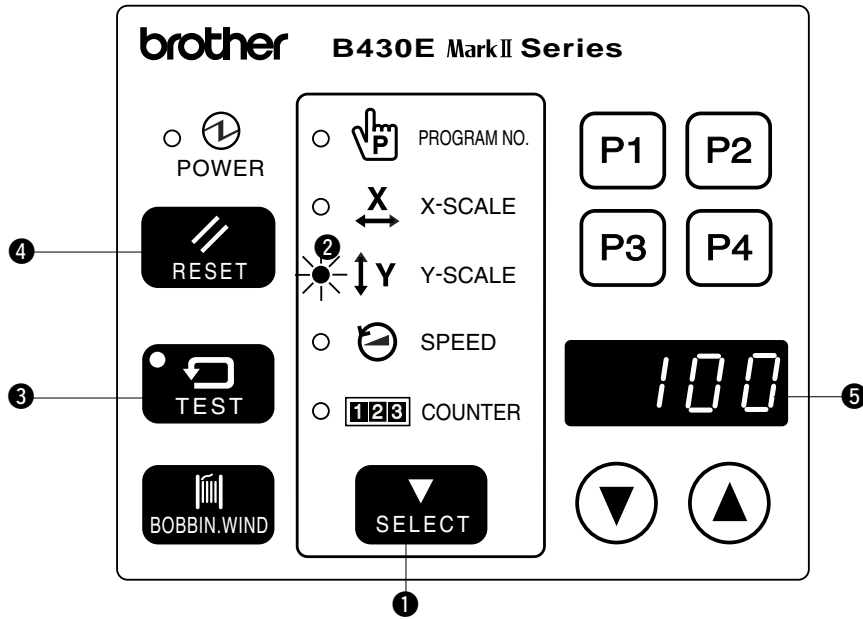

Specifications	Display	Notes
200V	[090 - 110]	"100" is displayed when the input voltage is 200 V.
220V	[100 - 120]	
230V	[105 - 125]	
100V 380V 400V 415V	[100 - 120]	"110" is displayed when the input voltage is 100V (for 100-V specs.), 380V (for 380-V specs.), 400V (for 400-V specs.) or 415V (for 415-V specs.).

1. Turn on the power switch.
2. Press the SELECT switch ① until the Y-SCALE indicator ② illuminates.
3. While pressing the TEST switch ③, press the RESET switch ④.
4. If the input voltage is normal, the input voltage conditions will be shown in the display window ⑤ as indicated in the table above.
5. Press the TEST switch ③ again to return the display to the normal condition.

10-14. Clearing all memory settings

If the sewing machine stops operating normally, the cause may be that an incorrect memory setting may have been made by means of the memory switch, for instance. In such cases, carry out the following procedure to clear the memory, and also check the DIP switch settings.

[Method]

While pressing the RESET switch, turn on the power. This will clear all of the memory setting.

NOTE:

This operation causes memory switches to be returned to their initial settings, and user program setting to be cleared.

10. STANDARD ADJUSTMENTS

10-15. Moving stitch patterns

- Programs which have already been programmed can be moved up, down and to the left and right. (However, such patterns will be reset if the power supply is turned off or the program number is changed.)
- The feed position can be set to the any position desired.

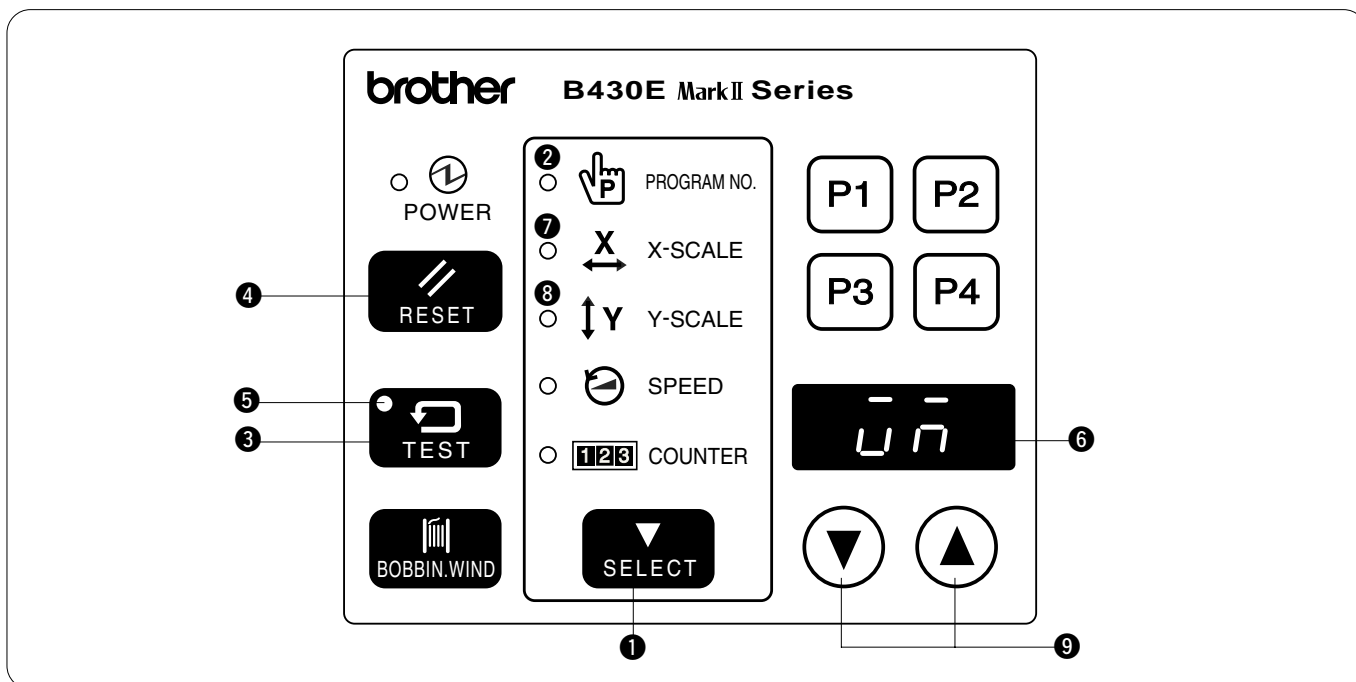

1. Select the program number, and then press the start switch once to move the feed mechanism to the sewing start position.
2. Press the SELECT switch ① until the PROGRAM NO. indicator ② illuminates.
3. While pressing the TEST switch ③, press the RESET switch ④.
* The TEST indicator ⑤ will illuminate and < UN > will appear in the display window ⑥.
4. Press the SELECT switch ① so that either the X-SCALE indicator ⑦ or Y-SCALE indicator ⑧ illuminates.
5. Press the DISPLAY SET switches ⑨ to move the feed mechanism one pulse at a time.
 - If the DISPLAY SET (▲) switch is pressed while the X-SCALE indicator is illuminated, the feed mechanism will move to the left.
 - If the DISPLAY SET (▼) switch is pressed while the X-SCALE indicator is illuminated, the feed mechanism will move to the right.
 - If the DISPLAY SET (▲) switch is pressed while the Y-SCALE indicator is illuminated, the feed mechanism will move down.
 - If the DISPLAY SET (▼) switch is pressed while the Y-SCALE indicator is illuminated, the feed mechanism will move up.
6. When the TEST switch ③ is pressed after the above fine adjustments have been made, the TEST indicator ⑤ and display window ⑥ will both switch off and movement of the stitch pattern will be completed.

NOTE:

When moving the stitch pattern, take the whole of the pattern area into consideration so that no parts extend outside the sewing area when the pattern is sewn.

- * If you would like to set the feed position to a desired position, carry out steps 2. to 6. above while the display window ⑥ is flashing. The stitch pattern will not be moved at this time.

10-16. Adjustment of air pressure (for pneumatic)

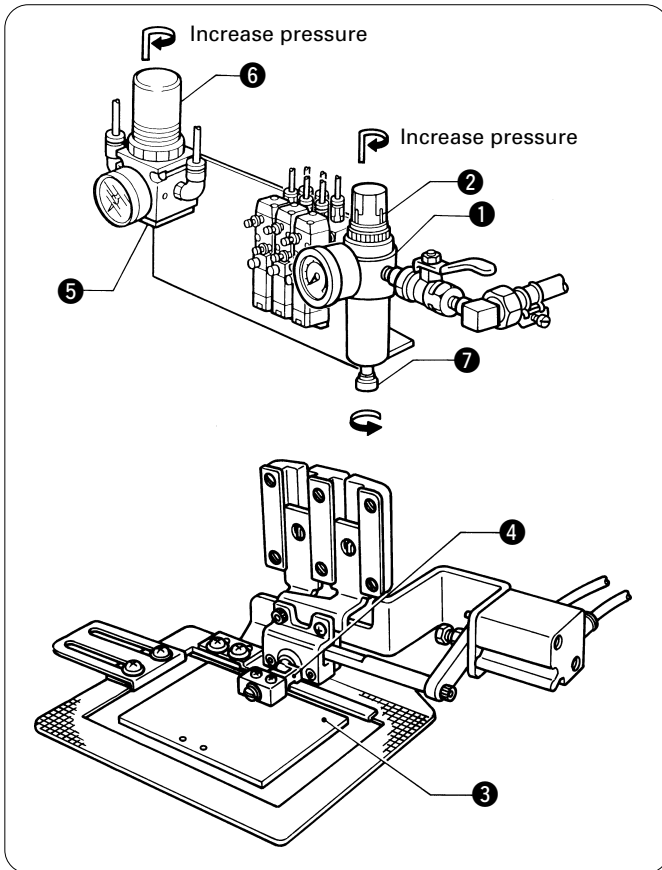

1. Air pressure should be 0.5 Mpa.
The air pressure can be adjusted by pulling up and turning the control knob ② on the integrator ①. After adjustment is complete, push the control knob ② downward to lock it.
2. Adjust the air pressure for the reversal cylinder to stay within such a range that the presser crank ④ rotates reversely when pressing the sewing material with the pressure plate ③. (Approx. 0.3 Mpa) For adjustment, pull up and, turn the control knob ⑥ on the air regulator ⑤.
After adjustment is complete, push the control knob ⑥ downward to lock it.
3. If water stands in the bottle of the integrator ①, turn the drain cock ⑦ in the direction indicated by an arrow to drain the water.

10-17. Adjustment of inner clamping device

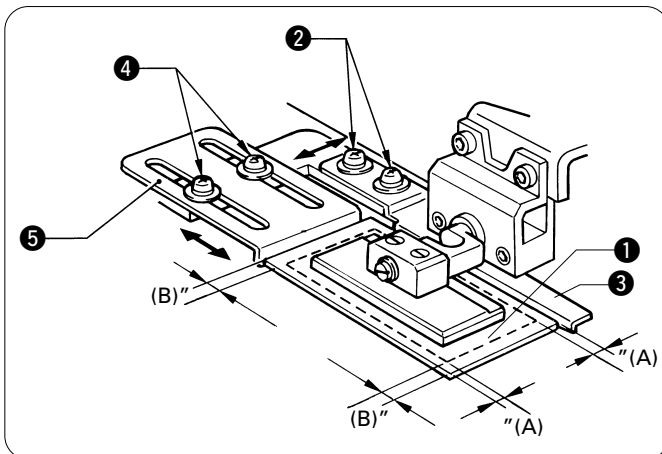

■ **Adjustment of the positioning plates**

Loosen the screws ②, and adjust the position of the positioning plate R ③ so that the label ① can be evenly laid out between the front and back seams (A).

Next, loosen the screws ④, and adjust the position of the positioning plate L ⑤ so that the presser plate can be evenly laid out between the left and right seams (B).

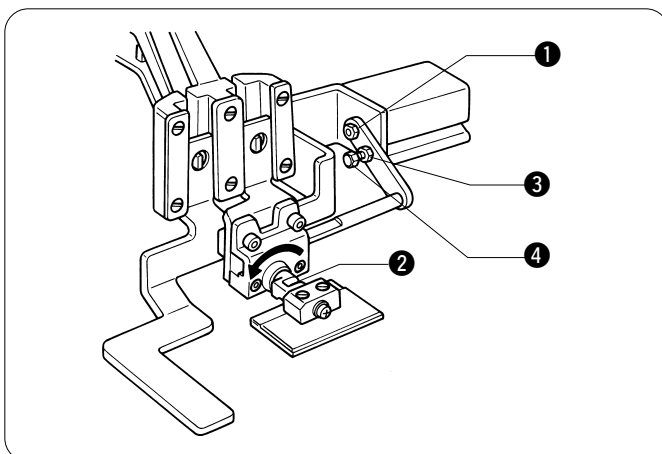

■ **Adjustment of the presser crank horizontal position**

Loosen the nut ③ and push in or pull out the adjusting bolt ④ so that the presser crank ② can be horizontal when the reversal cylinder plunger ① is moved to the left extreme.

11. USING THE COUNTERS

11-1. Using the bobbin thread counter

If you use the bobbin thread counter to set the number of articles which can be sewn with the amount of bobbin thread available, you can stop the bobbin thread running out in the middle of sewing a pattern.

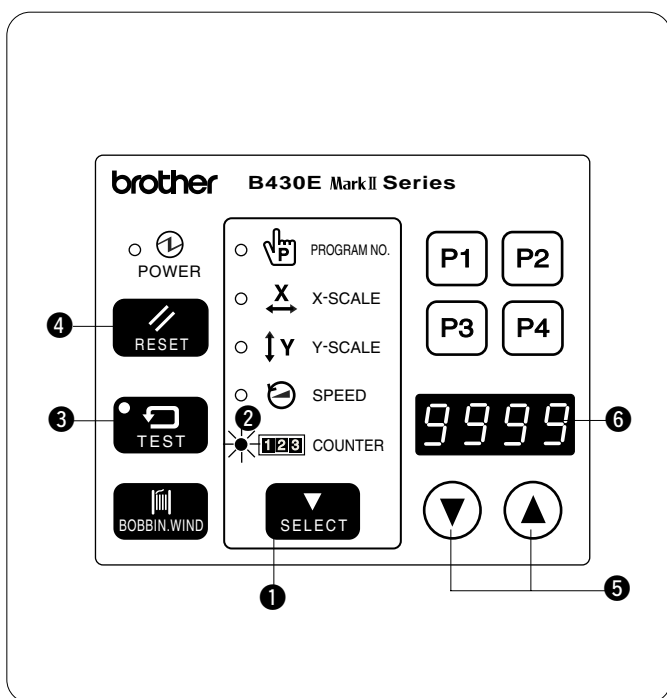

1. Press the SELECT switch ① until the COUNTER indicator ② illuminates.
2. While pressing the TEST switch ③, press the RESET switch ④.
 - * The COUNTER indicator ② will flash and the counter will switch to bobbin thread counter setting mode.
3. Press the DISPLAY SET switches ⑤ to set the number of articles to be sewn.
 - The bobbin thread counter can be set to sew a number of articles from one ("0001") through to 9999 ("9999").
 - If the bobbin thread counter is set to "0000", sewing is carried out without the number of articles sewn being counted.
 - If you press the RESET switch ④ while setting the bobbin thread counter, the setting will return to "0000".
4. Press the TEST switch ③.
 - * The number displayed in the display window ⑥ will then be stored as the bobbin thread counter setting.

5. Each time the sewing of a single article is completed, the number being displayed in the display window ⑥ will become smaller. When the number of articles set by the bobbin thread counter have all been sewn, "0000" will be displayed in the display window ⑥, and an alarm will start sounding continuously.
 - * The sewing machine will not operate during this time, even if the foot switch is depressed.
6. Replace the bobbin, and then press the RESET switch ④.
 - * The alarm will then stop sounding, and the number which was set in step 3. above will be re-displayed in the display window ⑥.

11-2. Using the production counter

The production counter can be displayed in the display window ⑥ separately from the bobbin thread counter.

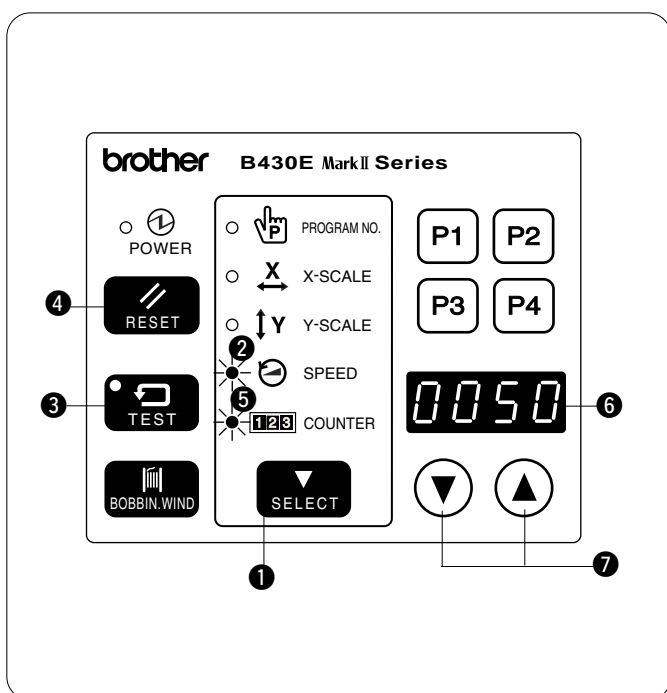

1. Press the SELECT switch ① until the SPEED indicator ② illuminates.
2. While pressing the TEST switch ③, press the RESET switch ④.
 - * The COUNTER indicator ⑤ and the SPEED indicator ② will illuminate, and the production counter will be displayed in the display window ⑥.
 - Press the RESET switch ④ to reset the production counter to "0000".
 - You can also press the DISPLAY SET switches ⑦ to set the production counter to the desired value.
3. When the foot switch is depressed, the sewing machine will start sewing.
4. If you press the TEST switch ③ or the SELECT switch ①, the display will return to showing the bobbin thread counter.

12. CHANGING FUNCTIONS USING THE DIP SWITCHES

12-1. Operation panel DIP switches

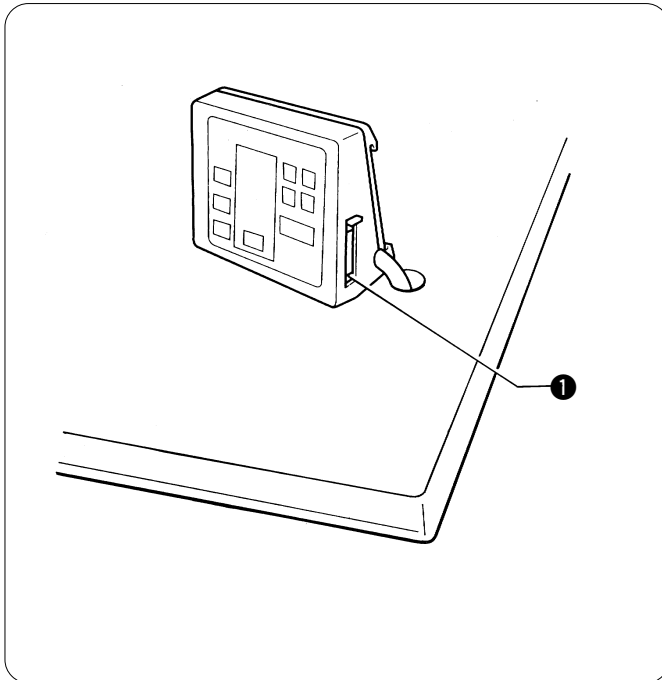

The functions shown in the table below can be changed by means of these DIP switches ❶.

* All DIP switches are set to OFF at the time of shipment.

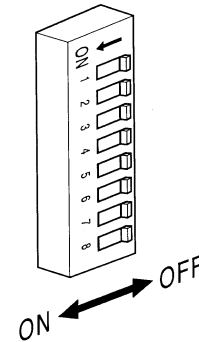

NOTE:

Always turn off the power before setting the DIP switches.

Switch	Motion when set to ON	
DIPA-1	Presser does not automatically lift after sewing is completed.	See "14. Setting the presser mode"
DIPA-2	Pedal mode is switched.	
DIPA-3	User program mode is available.	
DIPA-4	-	
DIPA-5	The presser does not rise automatically when a split is found.	
DIPA-6	Displays the enlargement/reduction ratio in millimeter units instead of as a percentage. (After changing this setting, be sure to carry out the auto-clear operation by referring to page 44.)	
DIPA-7	Enlargement of pattern size is not available.	
DIPA-8	Program number is fixed.	

12. CHANGING FUNCTIONS USING THE DIP SWITCHES

12-2. DIP switches inside the control box

⚠ DANGER



Wait at least 5 minutes after turning off the power switch and disconnecting the power cord from the wall outlet before opening the face plate of the control box. Touching areas where high voltages are present can result in severe injury.

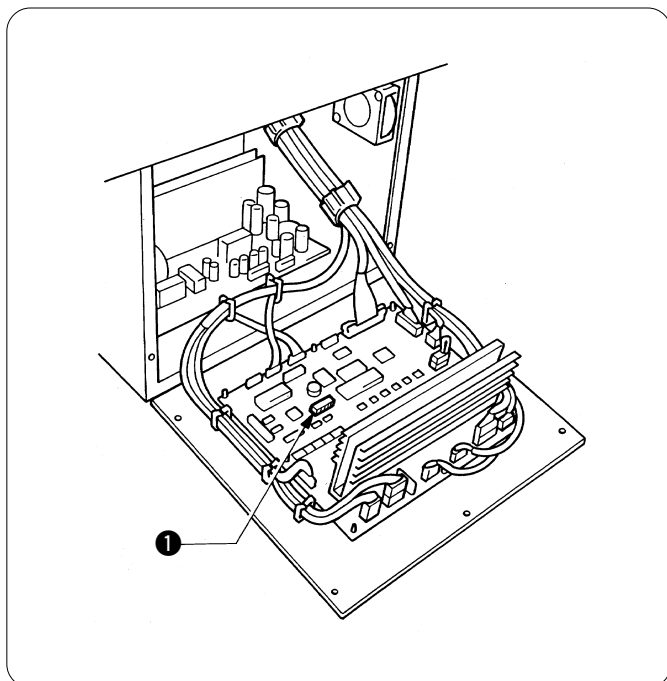

The functions can be changed as shown in the table below by changing the positions of the DIP switches

①.

* All DIP switches are set to OFF at the time of shipment.

NOTE:

When opening the cover, hold it securely so that it does not fall down.

Switch	Motion when set to ON
DIPB-1	First two stitches are sewn at a low speed of 260 rpm.
DIPB-2	Last two stitches are sewn at a low speed of 260 rpm.
DIPB-3	—
DIPB-4	Last two stitches are sewn at a low speed of 700 rpm.
DIPB-5	First two stitches are sewn at a low speed of 400 rpm.
DIPB-6	Low speed sewing is not performed at the start of sewing.
DIPB-7	The motor operates in reverse when the upper shaft stops, to return the needle bar to close to its highest position. *NOTE
DIPB-8	—

***NOTE:**

When the motor operates in reverse to raise the needle, the thread take-up will stop at a position which is lower than its normal stopping position. As a result, the thread take-up will rise slightly at the sewing start, and this may result in the thread pulling out under certain conditions.

12-3. Using user programs

User program ...

It can store sixteen different programs which can include details such as the program number, X scale, Y scale and sewing speed. If you are sewing certain patterns over and over again, it is useful to record the settings for these patterns into a user program.

Recording a user program

1. Turn off the power switch and then set DIP switch A-3 of the DIP switches ① to ON.

2. Turn on the power switch. While pressing the TEST switch ②, press the SELECT switch ③.

- * All of the menu indicators (④ to ⑧) will illuminate and the mode will switch to recording mode.
- * In addition, "PP 1" will appear in the display window ⑨ to indicate that user program No.1 is being recorded. (Once recording of No.1 is completed, No.2 will be displayed; once No.2 is completed, No.3 will be displayed. Thus the next unrecorded program letter is always displayed.)

3. Press the SELECT switch ③.
* The PROGRAM NO. indicator ④ will illuminate.

4. Press the DISPLAY SET switches ⑩ to select the number for the program that you would like to record.

5. Press the SELECT switch ③. * The X-SCALE indicator ⑤ will illuminate.

6. Press the DISPLAY SET switches ⑩ to select the X scale setting that you would like to record.

7. Press the SELECT switch ③. * The Y-SCALE indicator ⑥ will illuminate.

8. Press the DISPLAY SET switches ⑩ to select the Y scale setting that you would like to record.

9. Press the SELECT switch ③. * The SPEED indicator ⑦ will illuminate.

10. Press the DISPLAY SET switches ⑩ to select the speed setting that you would like to record.

11. Press the SELECT switch ③. * This completes the recording of user program No.1.
* "PP 2" will then appear in the display window ⑨, to indicate that user program No.2 is now being recorded.
Repeat steps 3. through to 11. to record further programs as desired.

12. Press the TEST switch ②. This completes the recording.
* The menu indicators (③ to ⑧) will all illuminate and "p1" will appear in the display to indicate that user program No.1 is currently selected.

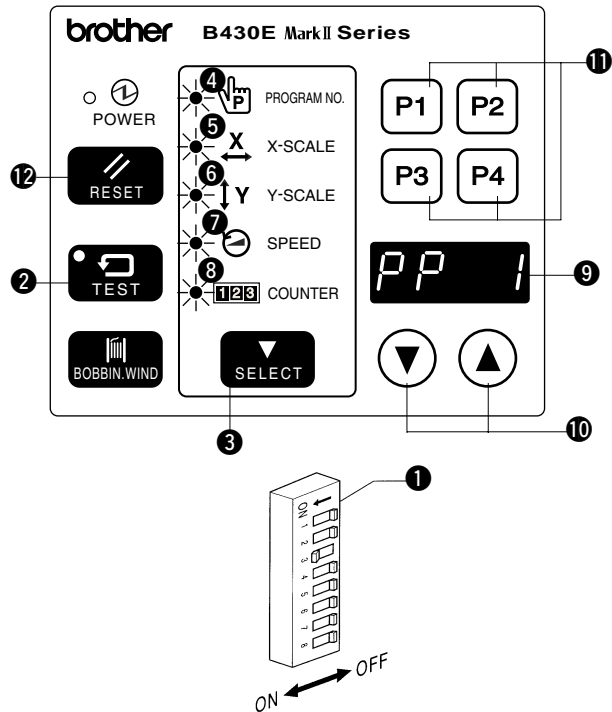

12. CHANGING FUNCTIONS USING THE DIP SWITCHES

Using a user program

1. Press the DISPLAY SET switches ⑩ to select the speed program number for the user program that you would like to use.

*The user program numbers P1 to P4 can also be selected using the user program switches ⑪.



2. Depress the foot switch to the second step.



3. Check the sewing pattern (see P.25), and then sew the pattern selected.

Clearing the user programs

1. Switch the machine to recording mode by the procedure in steps 2. of recording a user program.



2. Use the DISPLAY SET switches ⑩ to specify the user program number which is to be cleared of data.



3. Press the RESET switch ⑫.

* The buzzer will sound and the user program with the number selected will be cleared.

* If you press and hold the RESET switch ⑫ until after the buzzer has sounded twice, all user programs will be cleared.

NOTE:

If data has been recorded in user programs P1, P2, P3 and P4 and you then clear the data in user program P2, the contents of P3 will be transferred to P2, and the contents of P4 will be transferred to P3.

13. CHANGING SPECIAL FUNCTIONS USING THE MEMORY SWITCHES

The functions of the switches on the operation panel ① can be changed to carry out special functions.

NOTE:

After changing the memory switch settings, press the power switch to turn the power off and then back on again.

- Turn on the power switch.
- While pressing the TEST switch ②, press the BOBBIN. WIND switch ③.
* "00 - -" will appear in the display window ④.
- Press the DISPLAY SET switches ⑤ to set the two digits at the left of the display window ④ to the corresponding number (00 to 4F) of the function shown in the table below that you would like to select.
- When the BOBBIN. WIND switch ③ is pressed, the two spaces at the right in the display window will change from " - - " to "ON".
* If you press the RESET switch ⑥ at this time, memory switches will be returned to their initial settings (factory default settings).
- Press the TEST switch ②.
* The display will return to normal.

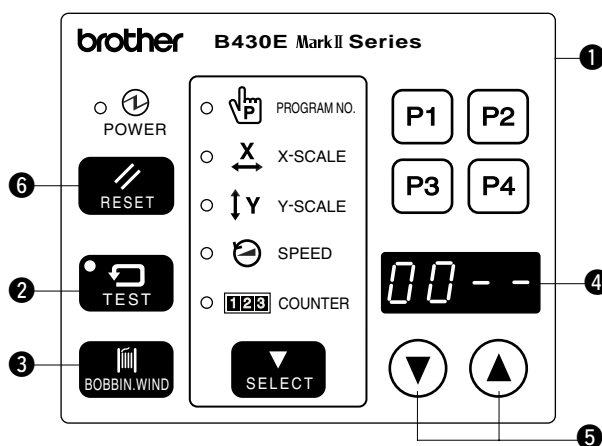

■ Memory switches 00 - 0F

Switch	Motion when set to ON	Initial value	
		Solenoid	Pneumatic
memo-00	At the end of sewing, the feed plate will be returned to the sewing start point via mechanical home position.	--	--
memo-01	Work clamp will move to the sewing start point, and then will be lifted.	ON	ON
memo-02	Feed will move automatically to the next starting point at the same time as a user program is switched. (Normally it moves to the starting point after sewing starts.)	--	--
memo-03	When sewing using programs, the programs which have been set will be sewn in numerical order. (Cycle sewing mode is set.)	--	--
memo-04	The sewing speed will be fixed at the minimum speed for the maximum pitch of the sewing data. (Set this to ON if you are concerned that variations in pitch may cause changes in the sewing speed.)	--	--
memo-05	Increases the presser solenoid lifting force (Set to ON when using the optional spring for extra-heavy material)	*1	--
memo-06	Enlargement and reduction ratio settings for X and Y become the same.	--	--
memo-07	The inner clamping device can be used with pneumatic specifications.	--	*2
memo-08	Test feeding is carried out stitch by stitch when the foot switch is depressed.	--	--
memo-09	The sewing start point becomes the reference point for enlargements and reductions. (The reference point for enlargements and reductions is normally the center of the sewing frame.)	--	--
memo-0A	–	--	--
memo-0b	–	--	--
memo-0c	Needle stops in up position during emergency stop.	--	--
memo-0d	The bar tacking stitches (with a pitch of less than 1 mm) are also enlarged and reduced. (Normally stitches with a pitch of less than 1 mm are not enlarged or reduced.)	--	--
memo-0E	Test feeding will be performed at the same speed as that for actual sewing. (This is used for checking feeding operation.)	--	--
memo-0F	After sewing is finished, the work clamp automatically opens and closes once (practice operation).	--	--

*1 ON for solenoid/heavy material specifications, and "--" for solenoid/medium material specifications

*2 ON when the inner clamping device is being used, and "--" at other times

13. CHANGING SPECIAL FUNCTIONS USING THE MEMORY SWITCHES

■ Memory switches 10 - 1F

Switch	Motion when set to ON	Initial value	
		Solenoid	Pneumatic
memo-10 - memo-11	—	--	--
memo-12	Pneumatic wiper can be used. (Pneumatic wiper is available by special order.)	--	--
memo-13	The inner clamping device moves forward at the 1/4-way mark and returns at the 3/4-way mark for the pattern being sewn.	--	--
memo-14	Solenoid wiper can be used.	--	ON
memo-15	When using the inner clamping device, shunting to prevent interference between the inner clamping device and the needle is not carried out after the sewing end.	--	--
memo-16	Needle cooler output is enabled. (Needle cooler is available by special order.)	--	--
memo-17	Thread take-up device is not operated at the sewing end.	--	--
memo-18	Thread take-up device operates one stitch before the sewing end.	--	--
memo-19	For solenoid specifications, presser position errors are not detected.	--	--
memo-1A	Needle up stop position errors are not detected.	--	--
memo-1b	Presser can be moved up and down before the home position is detected. (Normally the presser cannot be moved up and down until after the home position has been detected.)	--	--
memo-1c	—	--	--
memo-1d	For pneumatic specifications, the air pressure detection switch is enabled. (The air pressure sensor is a special-order option.)	--	--
memo-1E	Errors can be reset using the EMERGENCY STOP switch.	--	--
memo-1F	Thread is not trimmed when an emergency stop occurs during sewing.	--	--

■ Memory switches 20 - 2F

Switch	Motion when set to ON	Initial value	
		Solenoid	Pneumatic
memo-20	Machine head from previous B430E series is used. (Only the operation panel and box are Mark II.)	--	--
memo-21	Rotating-type thread breakage detector operates. (Device is available by special order.)	--	--
memo-22	During thread breakage detection, sensitivity is decreased from 8 to 14 stitches at the sewing start. (Sensitivity during sewing is three stitches.)	--	--
memo-23	When DIP switch A-8 is simultaneously ON, setting values changed using the operation panel are ignored.	--	--
memo-24	The lower thread sensor operates. (The lower thread sensor is a special-order option.)	--	--
memo-25 - memo-2F	—	--	--

13. CHANGING SPECIAL FUNCTIONS USING THE MEMORY SWITCHES

■ Memory switches 30 - 4F

30 to 4F are set by entering two-digit values.

These values are incremented using the P2 switch, and decremented using the P4 switch.

Switch	Possible setting range	Units	Initial value	Explanation
memo-30	0 - 99	mm	99	Limits the maximum area in the horizontal direction (X) (If the value is set to 99, the maximum length allowed will be 100 mm.)
memo-31	0 - 60	mm	60	Limits the maximum area in the vertical direction (Y)
memo-32	12 - 25	× 100rpm	25	Changes the maximum sewing speed.
memo-33	1 - 10	× 7.5°	5	Changes the feed timing 1 (Fast) ←5 (Standard) →10 (Slow)
memo-34	0 - 5	Needle	0	The sewing speed at the sewing start is 400 rpm for the specified number of stitches.
memo-35	3 - 9	× 100rpm	4	Changes the sewing start speed specified by memo-34.
memo-36	—	—	—	—
memo-37	1 - 20	× 7.5°	10	Changes the feed timing one stitch before the sewing end. 1 (Fast) ←10 (Standard) →20 (Slow)
memo-38	1 - 20	× 7.5°	10	Changes the feed timing two stitches before the sewing end.
memo-39	1 - 20	× 7.5°	10	Changes the feed timing for the third stitch at the sewing start.
memo-3A	1 - 20	× 7.5°	10	Changes the feed timing for the second stitch at the sewing start.
memo-3b	1 - 20	× 7.5°	10	Changes the feed timing for the first stitch at the sewing start.
memo-3c - memo-3F	—	—	—	—
memo-40	1 - 5	—	4	Changes the test feeding speed (with no material). 1 (Fast) ←→5 (Slow)
memo-41	—	—	—	—
memo-42	0.5 - 10	—	0	Changes the work clamp operating mode for pneumatic specifications. Refer to "14. Setting the work clamp mode" for details on the setting values. When set to "0", the mode is selected according to the settings for DIP switches A-1 and A-2.
			5	Specification with inner clamping device
memo-43	1 - 3	—	3	Changes the allowable speed/sewing pitch. 1 (Fast) ←→3 (Standard)
memo-44	0 - 3	—	0	Changes the path taken when moving from the machine home position to the start position. 0: Across inside of work clamp 1: Top-left 2: Bottom-left 3: Bottom-right
			1	Specification with inner clamping device (Does not pass across inside of clamp)
memo-45 - memo-4F	—	—	—	—

13. CHANGING SPECIAL FUNCTIONS USING THE MEMORY SWITCHES

13-1. Using the cycle sewing function

—What is the cycle sewing function?—

The cycle sewing function lets you program up to four patterns for cycle sewing of patterns in a predetermined order.

Recording a cycle sewing program

1. Set DIP switch ①-3 to ON, and then record the patterns which you would like to use for cycle sewing. (Refer to "12-3. Using user programs".)

* Cycle sewing cannot be performed using patterns (P1 to P16) which have not had a user program assigned.

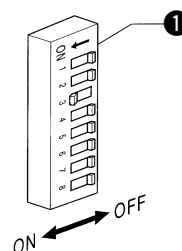

2. Set the memo-03 switch to ON. (Refer to page 52 for how to do this.)

3. While pressing the TEST switch ②, press the SELECT switch ③.

* All of the menu indicators (④ to ⑧) will illuminate and the mode will switch to recording mode.

4. Press the P1 switch ⑨.

• "Pc 1" will appear in the display window ⑩ to indicate that cycle sewing program No. 1 is being recorded.

* Programs P2, P3 and P4 switches can also be used for programming.

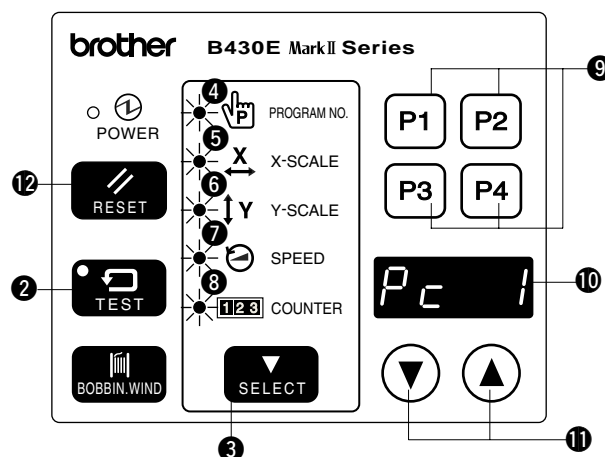

5. Press the SELECT switch ③. *The PROGRAM No. indicator ④ will illuminate and "1- -" will appear in the display window ⑩.

6. Press the DISPLAY SET switches ⑪ to select the number for the user program that you would like to record.

7. Press the SELECT switch ③. *"2- -" will appear in the display window ⑩.

8. Press the DISPLAY SET switches ⑪ to select the number for the user program that you would like to record.

9. Repeat steps 5. and 6. to record all programs which you would like to include for cycle sewing.

* After "9- -" is displayed, "A- -", "b- -", "c- -", "d- -", "E- -" and "F- -" will be displayed in that order so that up to the 15th pattern can be recorded.

* If you would like to return to a previous number during the recording procedure, press the P1 switch so that "Pc 1" is displayed, and then return to step 4.

10. Press the TEST switch ②.

• This completes the setting of cycle sewing program No. 1.

* The menu indicators (④ to ⑧) will all illuminate and "c1-1" will appear in the display window ⑩ to indicate that the cycle sewing program No.1 is currently selected.

Using a cycle sewing program

1. When "c1-1" is flashing in the display window ⑩, press the foot switch to the second step.



2. Start sewing.



3. "c1-1", "c1-2", "c1-3" are sewn in order for each article, and when the last-recorded pattern has been sewn, the display returns to "c1-1".

* If you press one of the DISPLAY SET switches ⑪ when "c1-*" is displayed, you can return to the previous stitch pattern or skip a stitch pattern.

* If you press the SELECT switch ⑬ when "c1-*" is displayed, you can check the contents of the recorded user program.

Clearing a cycle sewing program

1. Switch the machine to recording mode by the procedure in step 3. of recording a user program.



2. Use one of the P* switches (user program switches) to specify which cycle sewing program to clear.

* Press the P1 switch ⑨ if you would like to clear cycle sewing program No. 1. ("Pc 1" will be displayed.)



3. Press the RESET switch ⑫.

* The recorded contents of the specified cycle sewing program will then be cleared.

* If you press and hold the RESET switch ⑫ until after the buzzer has sounded twice, all cycle sewing programs will be cleared.

NOTE:

If you clear a user program after any cycle sewing programs have been recorded, all recorded cycle sewing programs will also be cleared.

14. SETTING THE WORK CLAMP MODE

14-1. Setting solenoid work clamp mode

Through the combination of DIP switches A-1 and A-2 on the operation panel, presser motions can be set as follows:

DIPA-1	DIPA-2	Pedal specifications	Raising the presser at the sewing end
–	–	Single pedal	Presser is raised automatically. (factory default settings)
ON	–	Single pedal	Presser is raised by pressing the pedal.
–	ON	Two pedals	Presser is raised automatically, then it is lowered by pressing the pedal.
ON	ON	Two pedals	Presser is kept lifted while the presser pedal is pressed.

14-2. Setting pneumatic work clamp mode

Through the combination of DIP switches A-1 and A-2 on the operation panel, presser motions can be set as follows:

■ When memo-42 = 0 (initial value for all specifications other than inner clamping specifications)

DIPA-1	DIPA-2	Pedal specifications	Raising the presser at the sewing end
–	ON	Single pedal	Presser is raised automatically.
ON	ON	Single pedal	Presser is raised by pressing the pedal.
–	–	Two pedals	Presser is raised automatically, then it is lowered by pressing the pedal. (factory default settings)
ON	–	Two pedals	Presser is kept lifted while the presser pedal is pressed.

■ Special memo-42 settings for pneumatic specifications

memo-42	Pedal specification	Raising the presser at the sewing end
5	Two pedals	Left presser drops when presser pedal is at the 1st step, and right presser drops when presser pedal is at the 2nd step. Raising is carried out in the reverse order. * Initial value for inner clamping specifications only * Setting used when using the light work clamp function (Refer to "14-3. Light work clamp".)
6	Two pedals	Right presser drops when presser pedal is at the 1st step, and left presser drops when presser pedal is at the 2nd step. Raising is carried out in the reverse order.
7	Two pedals	The left/right operating sequence changes alternately for each item sewn when using two-pedal operation. Starts with right → left.
8	Three pedals (Option)	The left pedal is used to raise and lower the left presser, and the right (center) pedal is used to raise and lower the right presser. The start (right) pedal is used to start sewing. Furthermore, when DIP switch A-2 is at ON, and if one presser is already lowered, pressing the start pedal causes the other presser to be lowered and then sewing starts.
9	Two pedals	When the presser pedal is depressed to the 1st step, both left and right pressers are raised simultaneously. When it is pressed to the 2nd step, sewing starts.
10	Two pedals	When the start pedal is depressed, both left and right pressers are lowered simultaneously. When the start pedal is released, sewing starts.

When memo-42 has been used to make a special setting, DIP switches A-1 and A-2 function as follows.

- When DIP switch A-1 is at ON, the pressers are not raised automatically at the sewing end.
- DIP switch A-2 is ignored except when memo-42 = 8.

14-3. Light work clamp

For pneumatic specifications, the hose connections can be changed so that the pressers are made to lower gently when the presser pedal is depressed to the 1st step, and firmly when the presser pedal is depressed to the 2nd step. This makes it easier to carry out position matching when attaching small articles such as labels.

[Memory switch setting]

Set memo-42 to 5 for two-pedal mode so that the pressers lower in the order of left then right for the standard hose connection. (Refer to "13. Changing special functions using the memory switches".)

■ Hose connections for light work clamp operation by both pressers

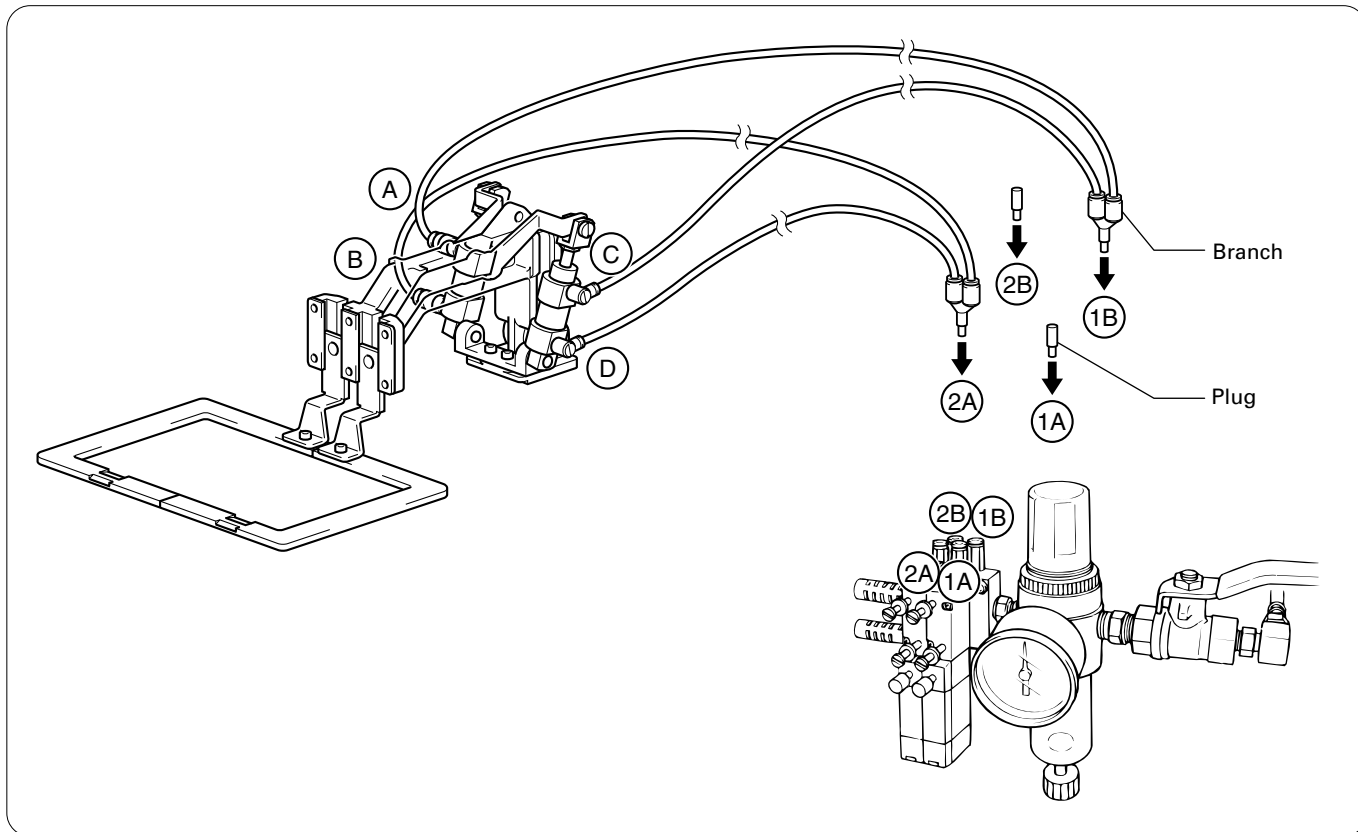

[How to use]

1. Depress the presser pedal to the 1st step to lower the pressers and apply a light pressure. You can then position small articles such as labels at this time.
2. After checking that everything is positioned correctly, depress the presser pedal to the 2nd step to firmly clamp the article being sewn.
3. Press the start pedal to start sewing.

■ Other hose connections and corresponding operations

The hoses can be connected in combinations other than the one shown above so that only one side of the presser operates in light work clamp mode.

Branch and plug connectors	Cylinder connectors				Operation when presser pedal is depressed to the 1st step
	A	B	C	D	
Branch: 1B, 2A Plug: 1A, 2B	1B	2A	1B	2A	Both pressers operate in light work clamp mode (example shown above)
Branch: 1B Plug: 2B	1B	2A	1B	1A	Only left presser lowers, and it lowers in light work clamp mode
Branch: 1B Plug: 2B	1B	1A	1B	2A	Only right presser lowers, and it lowers in light work clamp mode
Branch: 2A Plug: 1A	1B	2A	2B	2A	Both pressers lower, but only left presser lowers in light work clamp mode
Branch: 2A Plug: 1A	2B	2A	1B	2A	Both pressers lower, but only right presser lowers in light work clamp mode

14. SETTING THE WORK CLAMP MODE

14-4. Setting reverse work clamp mode

Basic setting

- If installing the inner clamping device as a later option, set the memory switches as follows. (This will complete inner clamping specification settings.)
 - Set the memo-07 switch to ON.
 - Set the memo-42 switch to "5".
- Make the following settings if necessary.

1. 1/2 reverse mode

The inner clamping device operates at the 1/2-way mark for the pattern being sewn.

Example

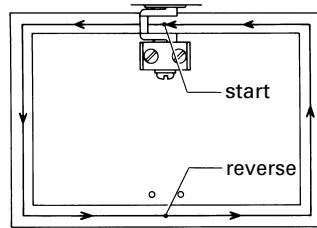

memo-13
-

2. 1/4 reverse mode

The inner clamping device operates at the 1/4-way and 3/4-way marks for the pattern being sewn.

Example

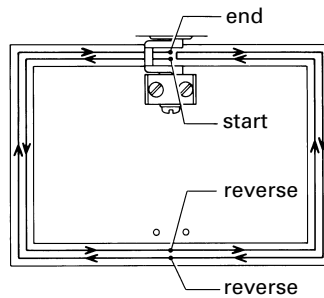

memo-13
ON

[Notes to sewing]

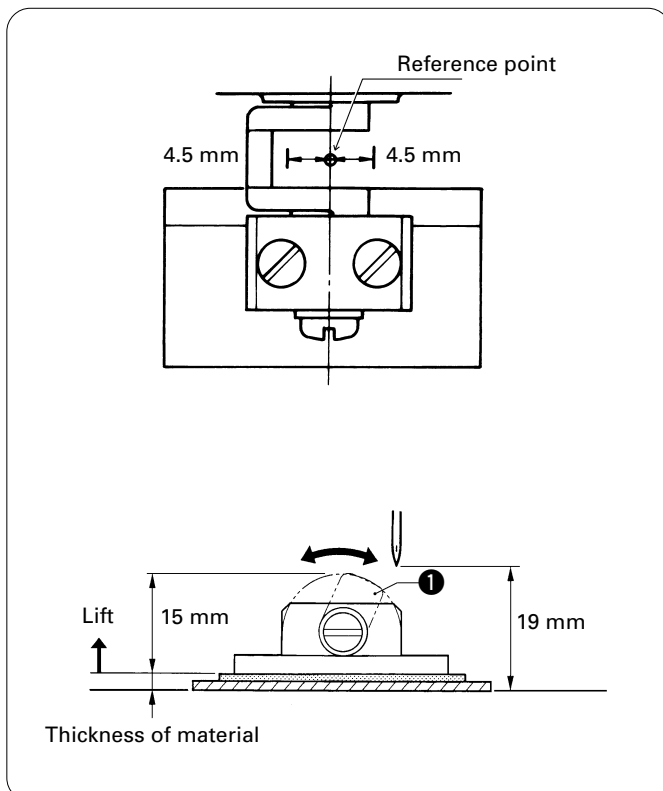

- Reverse stitching is possible within 4.5 mm left and right from the reference point. However, note that if a non-standard work clamp is being used, the reverse stitching area will become smaller.

- When the work clamp ❶ reverses after sewing is completed, the work clamps are retracted so that they do not touch the needle. However, sometimes it is not necessary to retract the work clamps if the material is thin.

In such cases, if memory switch memo-15 is set to on, the work clamps will not be retracted so that the cycle time can be shortened. However, if making this change to the setting, move the work clamp to the sewing end position (release the air and move the work clamp by hand) to check that the work clamps do not touch the needle.

15. TABLE OF ERROR CODES

DANGER



Wait at least 5 minutes after turning off the power switch and disconnecting the power cord from the wall outlet before opening the face plate of the control box. Touching areas where high voltages are present can result in severe injury.

If a malfunction should occur with the sewing machine, a buzzer will sound and an error code will appear in the display window. Follow the remedy procedure to eliminate the cause of the problem.

Code	Cause	Remedy
E-10	Emergency stop switch was pressed.	Turn the EMERGENCY STOP switch clockwise to release the lock, and then press the RESET switch to reset the error.
E-11	Emergency stop switch was pressed during sewing.	Turn the EMERGENCY STOP switch clockwise to release the lock, and then press the RESET switch to reset the error. You can then press the BOBBIN. WIND switch to repeat the sewing.
E-12	Emergency stop switch is being continually pressed, or emergency switch connection error.	Turn off the power and check.
E-13	Machine specification select connector is not connected properly.	Turn off the power and check if connectors P3 is disconnected.
E-20	Problem with machine motor stopping, or synchronizer connection error.	Turn off the power, and then turn the machine pulley to check if the machine has locked up. Check the synchronizer connection. Check if connectors P11, P12 and P13 are disconnected.
E-21	Machine motor operation error.	Turn off the power and check the ground wire connection.
E-30	Data is outside possible sewing area due to enlargement ratio setting.	Press the RESET switch, and then set the enlargement ratio again.
E-31	Stitch pattern data overlaps the sewing area when area limiting is active.	Press the RESET switch, and then reset the memory switches "30" and "31" or enlargement ratio.
E-32	The data format of the user program (% or mm) does not match the setting of DIP switch A-6.	After changing the setting of DIP switch A-6, clear all memory settings. (Refer to "10-14. Clearing all memory settings".)
E-40	Length of a stitch exceeds 10 mm.	Press the RESET switch, and then set the enlargement ratio again.
E-41	Abnormality in the sewing data.	If programming a new sewing data, repeat the procedure from the beginning.
E-42	Invalid program number specified.	Press the RESET switch and specify a correct number.
E-50	Needle bar does not stop when the needle is raised.	Turn the pulley to align the index mark with the needle up stop position. (Refer to "10-10. Adjusting the needle up stop position".) Check the V-belt tension. (Refer to "3-15. Installing the V-belt".)
E-60	Presser has not been lowered.	Refer to "17. Troubleshooting". Turn off the power and check the connection of presser sensor connector P1.
E-61	Presser cannot be raised.	
E-62	Presser is not raised.	
E-63	Presser cannot be lowered.	
E-70	Cooling fan does not operate.	Turn off the power, and then check if the cooling fan is blocked with scraps of thread.

15. TABLE OF ERROR CODES

Code	Cause	Remedy
E-80	Motor PROM is not correctly inserted.	Turn off the power and check.
E-81	Foot switch was depressed when the power was turned on.	Turn off the power and check.
E-82	An operation panel switch was depressed when the power was turned on.	Turn off the power and check the operation panel. Check that all panel cords are normal.
E-90	Abnormal drop in power supply voltage, or power was turned on again immediately after it was turned off.	Turn off the power and check the input voltage. After turning off the power, wait 3 seconds or more before turning it on again. (Refer to "10-13. Checking the input voltage".)
E-91	Abnormal rise in power supply voltage.	Turn off the power and check the input voltage. (Refer to "10-13. Checking the input voltage".)
E-A0	Home position cannot be detected (malfunction of home position sensor), or malfunction of power supply circuit board.	Turn off the power and check the connection of home position sensor connector P1.
E-b0	You tried to change the program number when DIP switch A-8 was set to ON.	Press the RESET switch. Set DIP switch A-8 to OFF before trying to change the program number.
E-b1	No sewing data available.	Replace the PROM with one which contains sewing data.
E-d0	Heat sink of control circuit board is abnormally hot.	Turn off the power and clean the air intake port of the box.
E-E0	Malfunction of EEPROM (malfunction of main circuit board).	Turn off the power, and turn it back on. If the error continually occurs, contact a qualified service technician.
E-E1	Corrupted EEPROM data, or main PROM version has been upgraded.	Press the RESET switch to reset the error. However, the data (memory switches, display and user programs) will be reset to the backup data or initialized.
E-E2	Corrupted EEPROM control information data.	Press the RESET switch to reset the error. However, the data (memory switches, display and user programs) will all be initialized.
E-F0	Solenoid short-circuit (malfunction of main circuit board), or power relay is not operating (malfunction of power supply circuit board).	Turn off the power and contact a qualified service technician.
E-F1	Bad connection in cable between power supply circuit board and main circuit board.	Turn off the power and check if connectors P16 is disconnected.
E-F2	Abnormal current detected in power supply circuit board.	Turn off the power and contact a qualified service technician.

■ Errors generated when optional equipment is connected

Code	Cause	Remedy
E-14	Thread breakage detected.	Turn the EMERGENCY STOP switch clockwise to release the lock, and then press the RESET switch to reset the error. You can then press the BOBBIN. WIND switch to repeat the sewing.
E-15	Air pressure drop error.	Turn off the power and check. If drops in air pressure are not being detected, clear all memory settings and then set the memo-1d switch to OFF.
E-16	Bobbin thread sensor mechanism error	Turn off the power and check. If the bobbin thread amount is not being detected, clear all memory settings and then set the memo-24 switch to OFF.

REFERENCE











segment LED alphabet

	Panel display	<i>A</i>	<i>b</i>	<i>c</i>	<i>d</i>	<i>E</i>	<i>F</i>	<i>6</i>	<i>H</i>	<i>L</i>	<i>o</i>
	Text display	A	b	c	d	E	F	6	H	L	o





16. GAUGE PARTS LIST ACCORDING TO SUBCLASSES

The following are standard gauge parts according to each specification.

(In the following table, parts marked with ★ are common with the LK3-B430E; parts with ☆ are common with the BAS-311E.)

Specification Part name	Medium materials	Heavy materials	With inner clamping device	Extra heavy materials
Needle hole plate 	(φ2.2) S49980-001 FM	(φ2.6) S10212-101 E	(φ2.2) S49980-001 FM	(φ2.6) S10212-101 E
Bobbin case assy 	159610-201 A ★	152690-301 B ★	159610-201 A ★	152690-301 B ★
	S15902-401 LA			★
Tension spring 	154339-001 A ★	154340-001 B ★	154339-001 A ★	154340-001 B ★
	S16074-101 LA			★
Screw 	154341-001			★
	S16492-101 LA			★
Spring, anti-spin 	159612-001 A ★	154342-001 B ★	159612-001 A ★	154342-001 B ★
	S15667-001 LA			★
Bobbin 	159613-051		★	154663-001 B ★
	S44633-001 LAN			★
Shuttle hook, W/BOX 	152685-903 A ★	152687-902 B ★	152685-903 A ★	152687-902 B ★
	S15662-992 LA ★	S15663-991 LB ★	S15662-992 LA ★	S15663-991 LB ★
Shuttle race body 	★ 152682-101 A	★ 152686-101 B	★ 152682-101 A	★ 152686-101 B
Spring tension 	★ 104525-001	★ 107606-001	★ 104525-001	S06548-001 C
Spring 	★ 145519-001	★ 144588-001 B	★ 145519-001	★ 144588-001 B

16. GAUGE PARTS LIST ACCORDING TO SUBCLASSES

Specification Part name	Medium materials	Heavy materials	With inner clamping device	Extra heavy materials
Thread guide, needle bar  A  B	S41222-101 B ★	152890-001 A ★	S41222-101 B ★	S02439-001 B ★
Needle assy	107415-414 ★	S37928-419 ★	145646-414 ★	145646-425 ☆
Needle 	DP × 5 #14 107415-014 ★	DP × 17 NY #19 S37928-019 ★	DP × 17 #14 145646-014 ★	DP × 17 #25 145646-025 ☆
Work clamp blank 	434-1R ★ S42030-001	434-2R ★ S42032-001	154256-101 A ★	-
	434-1L ★ S42031-001	434-2L ★ S42033-001		
Feed plate blank 	434-1 ★ S42034-001	434-2 ★ S42035-001	434-R1 ★ S43459-001	-

<Gauge parts>

The following are provided as optional gauge parts.

Each work clamp pair is used in combination with the feed plate directly below them.

- Work clamps R, L and feed plate

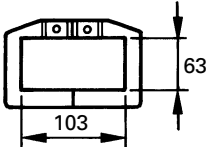
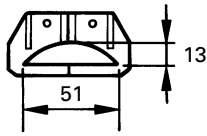
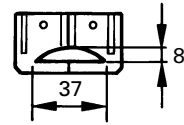
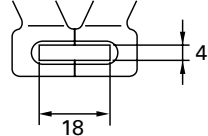
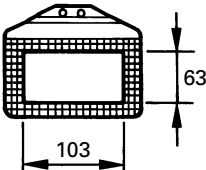
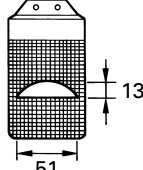
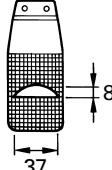
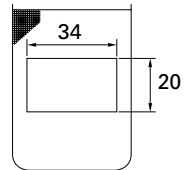
	1	2	3	4
R	153493-001	S23377-001 (519)	S27836-001 (895)	156085-001 (M)
L	153498-001	S23378-001 (519)	S27837-001 (895)	156086-001 (M)
Work clamp				
Feed plate	153503-001	S23379-001 (519)	S27838-001 (895)	156087-001 (M)
				

16. GAUGE PARTS LIST ACCORDING TO SUBCLASSES

	5	6
R	156082-001 (L)	156088-001 (S)
L	156083-001 (L)	156089-001 (S)
Work clamp		
Feed plate	156084-001 (L)	156090-001 (S)

• Gauge assy, 434E MK2

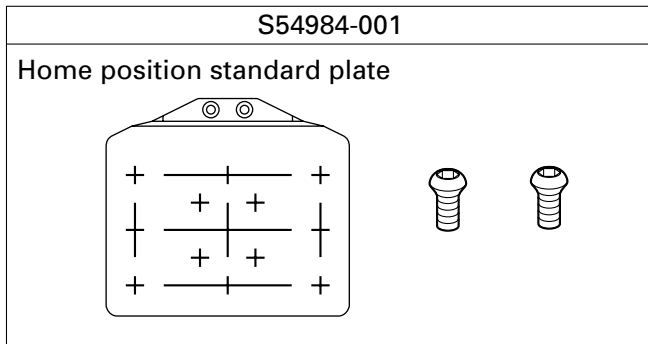

• Needle hole plate

A	S10211-001	AF	S51449-001	BZ	S41013-001	D	S29997-001	E	S10212-101	ED	S30925-001
F	S10213-001	FD	S30926-001	FM	S49980-001	H	S30450-001	L	S25127-001	M	S34348-001
3	S40217-001										

17. TROUBLESHOOTING

Problem	Cause	Check	Remedy	Page
Work clamp does not rise.	Work clamp operation is sluggish.	Sliding part of the work clamp lubrication	Grease the sliding part of the work clamp.	40
	Work clamp lift amount is too great.	Distance between work clamp and top of needle plate	Adjust the height of the work clamp to within 17 mm.	40
	Too much friction between presser plate and presser arm lever support.	Presser plate and presser arm lever support lubrication	Grease the presser plate and presser arm lever support.	40
	Work clamp is contacting thread wiper.	Thread wiper standby position	Adjust the position of the thread wiper.	42
Work clamp does not drop.	Presser lifter link is not moving back.	Link return spring is unhooked.	Hook the link return spring properly.	
Work clamp lift amount is incorrect.	Incorrect position of presser arm lever plate.	Distance between work clamp and top of needle plate	Adjust the work clamp lift amount.	40
Thread wiper does not operate correctly.	The thread wiper is obstructing the needle.	Clearance between thread wiper and needle tip	Adjust the height of the thread wiper.	42
	Thread wiper position is incorrect.	Thread wiper position	Adjust the operating distance of the thread wiper.	42
Lower thread winds to one side.	Bobbin winder thread tension stud height is incorrect.	Bobbin winder thread tension stud height	Adjust the height of the thread tension stud.	27
Lower thread winding amount is incorrect.	Bobbin presser position is incorrect.	Thread winding amount	Adjust the position of the bobbin presser.	27
Threads comes unthreaded.	Stitches being skipped at the sewing start.	Refer to "Skipped stitches occur"	Refer to "Skipped stitches occur".	
	Uneven upper thread length.	Upper thread length	Adjust the sub-tension.	29
	Upper thread is too short.	Thread take-up lever stroke	Adjust the thread take-up lever stroke.	37

Problem	Cause	Check	Remedy	Page
Upper thread breaks.	Upper thread tension is too strong.	Upper thread tension	Adjust the upper thread tension.	29
	Needle is installed incorrectly.	Needle direction	Install the needle so that the groove is facing forward.	26
	Thread is too thick for the needle.	Thread and needle	Use the correct thread for the needle.	26
	Thread take-up spring tension and height are incorrect.	Thread take-up spring tension and height	Adjust the tension and height of the thread take-up spring.	30
	Damaged or burred rotary hook, needle hole plate or needle.	Damage or burring	File smooth or replace the affected part.	/
	Thread melting (synthetic thread)	Thread edge	Use a thread cooling device (optional).	68
Lower thread breaks.	Lower thread tension is too strong.	Lower thread tension	Adjust the lower thread tension.	29
	Corners of needle hole plate or bobbin case are damaged.	Damage	File smooth or replace the affected part.	/
Skipped stitches occur.	Clearance between needle and rotary hook tip is too great.	Needle clearance	Adjust the needle clearance.	36
	Incorrect needle and rotary hook timing.	Needle bar lift amount	Adjust the needle bar lift amount.	35
	Driver is contacting needle more than is necessary.	Clearance between driver and needle	Adjust the driver needle guard.	36
	Needle is bent.	Bent needle	Replace the needle.	/
	Needle is installed incorrectly.	Needle direction	Install the needle so that the groove is facing forward.	26
Needle breaks.	Needle is touching the rotary hook.	Needle clearance	Adjust the needle clearance.	36
		Needle bar lift amount.	Adjust the needle bar lift amount.	35
	Needle is bent.	Bent needle	Replace the needle.	/
	Needle is too thin.	Needle and thread	Use the correct needle for the material.	/

17. TROUBLESHOOTING

Problem	Cause	Check	Remedy	Page
Upper thread is not trimmed.	Fixed knife is blunt.	Fixed knife blade	Sharpen or replace the fixed knife.	/
	Movable knife does not pick up the thread.	Shuttle race thread guide position	Adjust the position of the shuttle race thread guide.	36
		Needle bar lift amount	Adjust the needle bar lift amount.	35
	The movable knife does not pick up the thread because of skipped stitches at the sewing end.	Skipped stitches at sewing end	Refer to "Skipped stitches occur".	/
	Movable knife position is incorrect.	Movable knife position	Adjust the position of the movable knife.	37
	Sub-tension is too weak.	Sub-tension	Turn the sub-tension nut to adjust the tension.	29
Thread jamming.	Thread take-up spring tension and height are incorrect.	Thread take-up spring tension and height	Adjust the tension and height of the thread take-up spring.	30
	Incorrect needle and rotary hook timing.	Needle bar lift amount	Adjust the needle bar lift amount.	35
	Shuttle race thread guide is not separating the threads.	Shuttle race thread guide position	Adjust the position of the shuttle race thread guide.	36
Poor seam finish on reverse side of material.	Shuttle race thread guide is not separating the threads.	Shuttle race thread guide position	Adjust the position of the shuttle race thread guide.	36
	Upper thread is not properly tight.	Upper thread tension	Adjust the upper thread tension.	29
	Uneven upper thread length.	Upper thread length	Adjust the sub-tension.	29
	Upper thread is too long.	Thread take-up lever stroke	Adjust the thread take-up lever stroke.	37
Incorrect thread tightness.	Upper thread tension is too weak.	Upper thread tension	Adjust the upper thread tension.	29
	Lower thread tension is too weak.	Lower thread tension	Adjust the lower thread tension.	29
	Thread take-up spring tension and height are incorrect.	Thread take-up spring tension and height	Adjust the tension and height of the thread take-up spring.	30
Inner clamping device does not operate.	Work clamp pressure is too strong.	Work clamp pressure	Adjust the work clamp pressure so that the inner clamping device operates.	46

18. OPTIONAL PARTS

- Two-pedal foot switch The presser switch and the start switch have been separated, giving the operator more flexibility to select the best method of working.

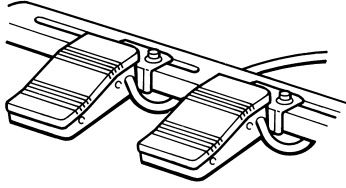

- Two-step foot switch This is a pedal-type foot switch.

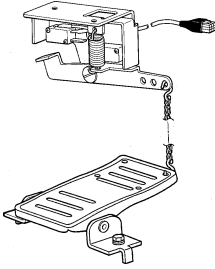

- Liquid cooling tank This helps to prevent thread breakages caused by friction when using synthetic threads. Fill the tank with silicone oil (100 mm²/s).

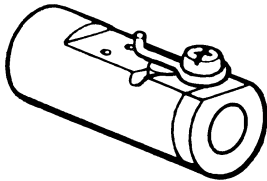

- Solenoid thread wiper This wipes the thread independently of the work clamp operation.

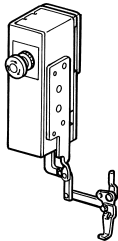

- Three-pedal foot switch The switch has an independent left work clamp switch (left side), right work clamp switch (center) and start switch (right side).
(For pneumatic)

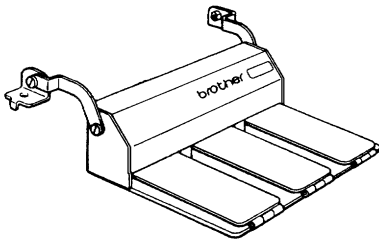

brother[®]

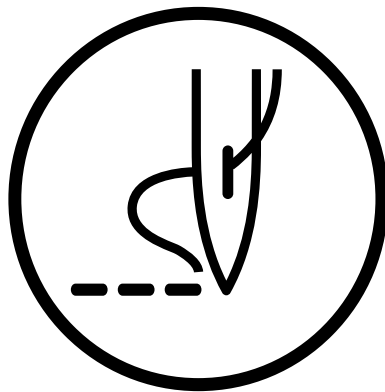

INSTRUCTION MANUAL

BROTHER INDUSTRIES, LTD.

15-1, Naeshiro-cho, Mizuho-ku, Nagoya 467-8561, Japan. Phone: 81-52-824-2177

Printed in Japan

118-V34
S91V34-002
2000.06. B (1)