

Skipping stitch detection  
Bobbin rotation detection  
Bobbin loading verification  
Bobbin thread remaining amount detection

**M H A - C S D 1 0 0**

**( M H A - A S G )**

(Brother BAS-300G-484 3RH exclusive)

## Instruction Manual

Thank you for purchasing our product.

Please be sure to read this manual before using MHA-CSD100  
and keep it within easy access.

## HAMS CORPORATION

59-2 Nishiakeda-cho, Higashikujo,  
Minami-ku, Kyoto 601-8045 Japan  
Phone:+81-75-661-1134 Fax:+81-75-681-0908  
E-mail : [info@hams-jp.com](mailto:info@hams-jp.com)  
<http://www.hams-jp.com/>

2011.12.22  
2013. 5.1

# Contents

1. Installation .....	1
(1) General .....	1
(2) Wiring, Piping .....	3
(3) Position adjustment of Skip stitch detection and bobbin rotation detection ..	5
(4) Position adjustment of Bobbin thread detection device .....	7
(5) Machine Control Program Updating .....	9
2. Adustment of Detection sensor .....	10
(1) Skip stitch detection sensor .....	10
(2) bobbin rotation detection sensor .....	10
(3) bobbin inserting detection sensor .....	11
(4) bobbin thread remains detection sensor .....	11
3. Memory Switch .....	12
4. Error Code .....	12
5. Device Mechanism .....	13

# 1. Installation

## (1) General

※ Cautions of bobbin rotation detection sensor system.

At the beginning of sewing, if the bobbin thread is not coming out, it would takes 27 seconds at least for the machine stops.

(Bobbin rotation detection sensor will ignore the first 10 sewings, and judge based on the following 17 sewings.

So it would takes 10 seconds + 17 seconds at least for the sensor to judge.)

Fit the device as stated below.

it is necessary to stiletto on the plate to fit the Skip stitch detection sensor and bobbin rotation detection sensor.

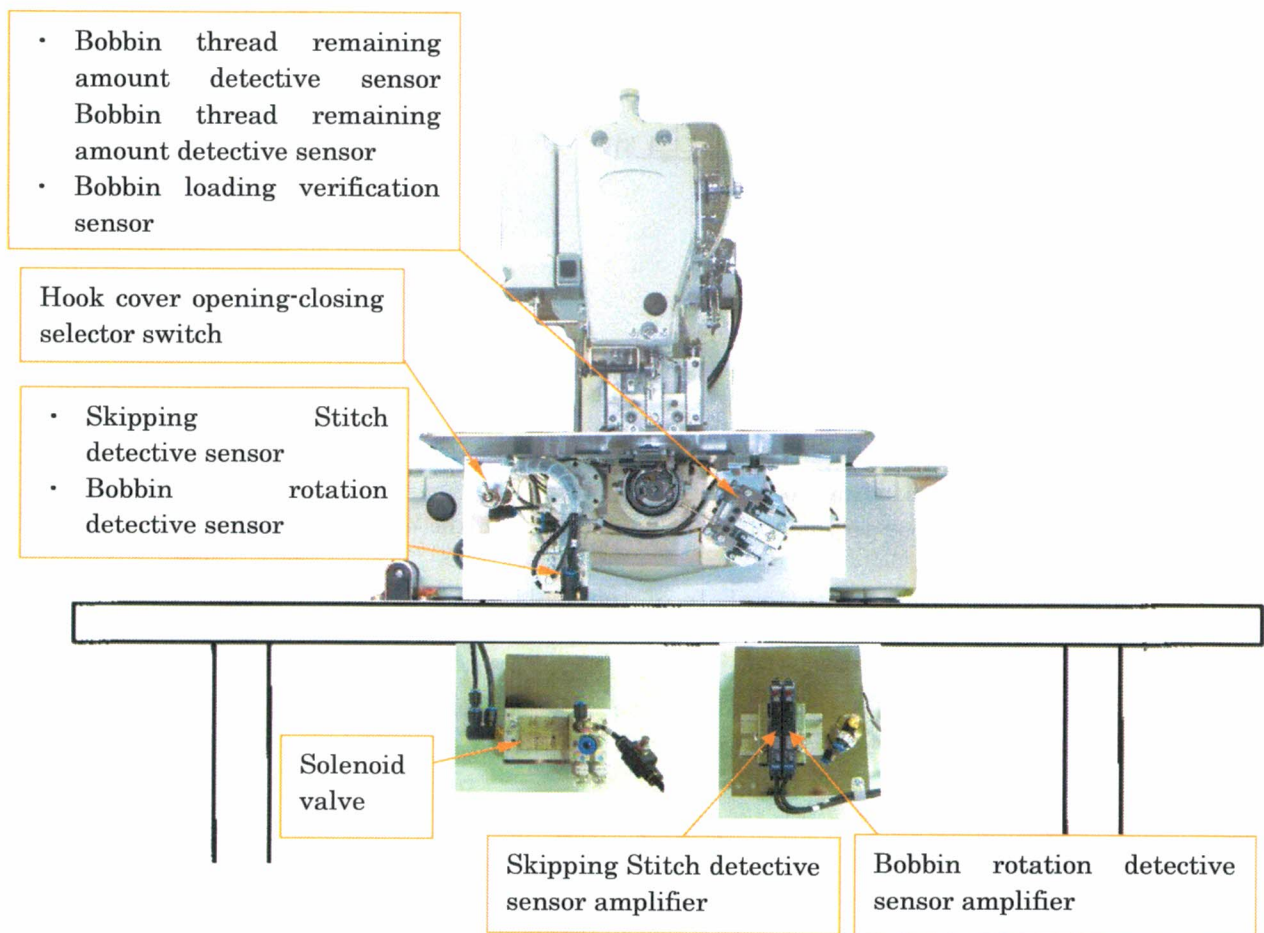

Stiletto for detection sensor

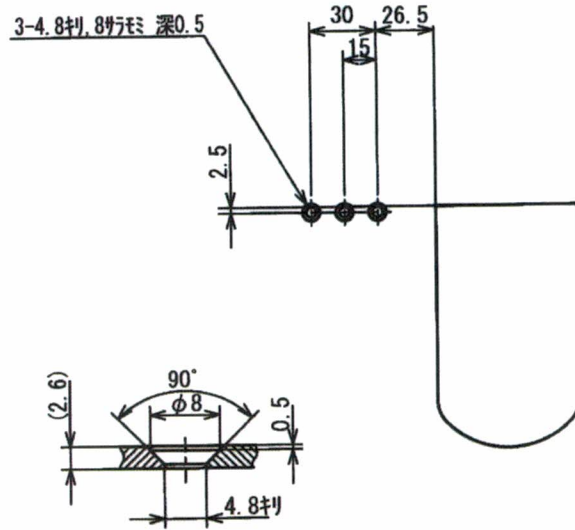

Installation of sensor fiber

Use the adaptor including to install the fiber.

- 1) Insert each fiber to the hole of adaptor to reach the end of adaptor holes.
- 2) Insert the adaptor into the hole of the amplifier until it stops. And close quick release lever.

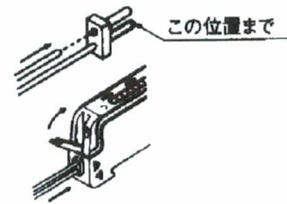

• Single-core fiber is installed on the transmitter side, Multiple-core fiber is on the receiver side.

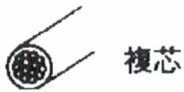

複芯

Multiple-core fiber



単芯

Single-core fiber

## (2) Wiring & Piping

### 1) Wiring

Connect the sensor code connector with 「P24」 and 「P25」 of main PCB of Brother machine.

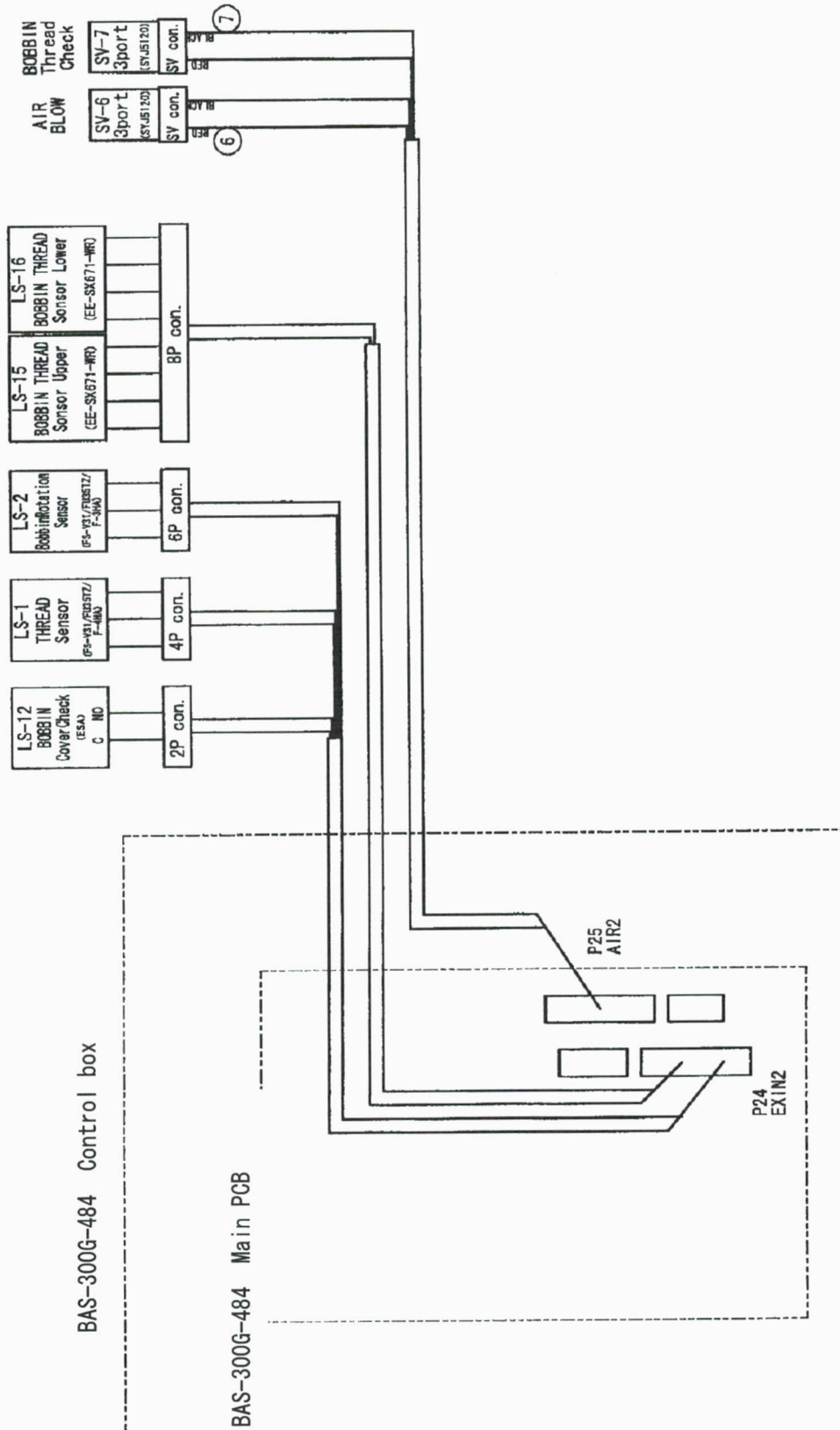

2) Piping

Piping diagram

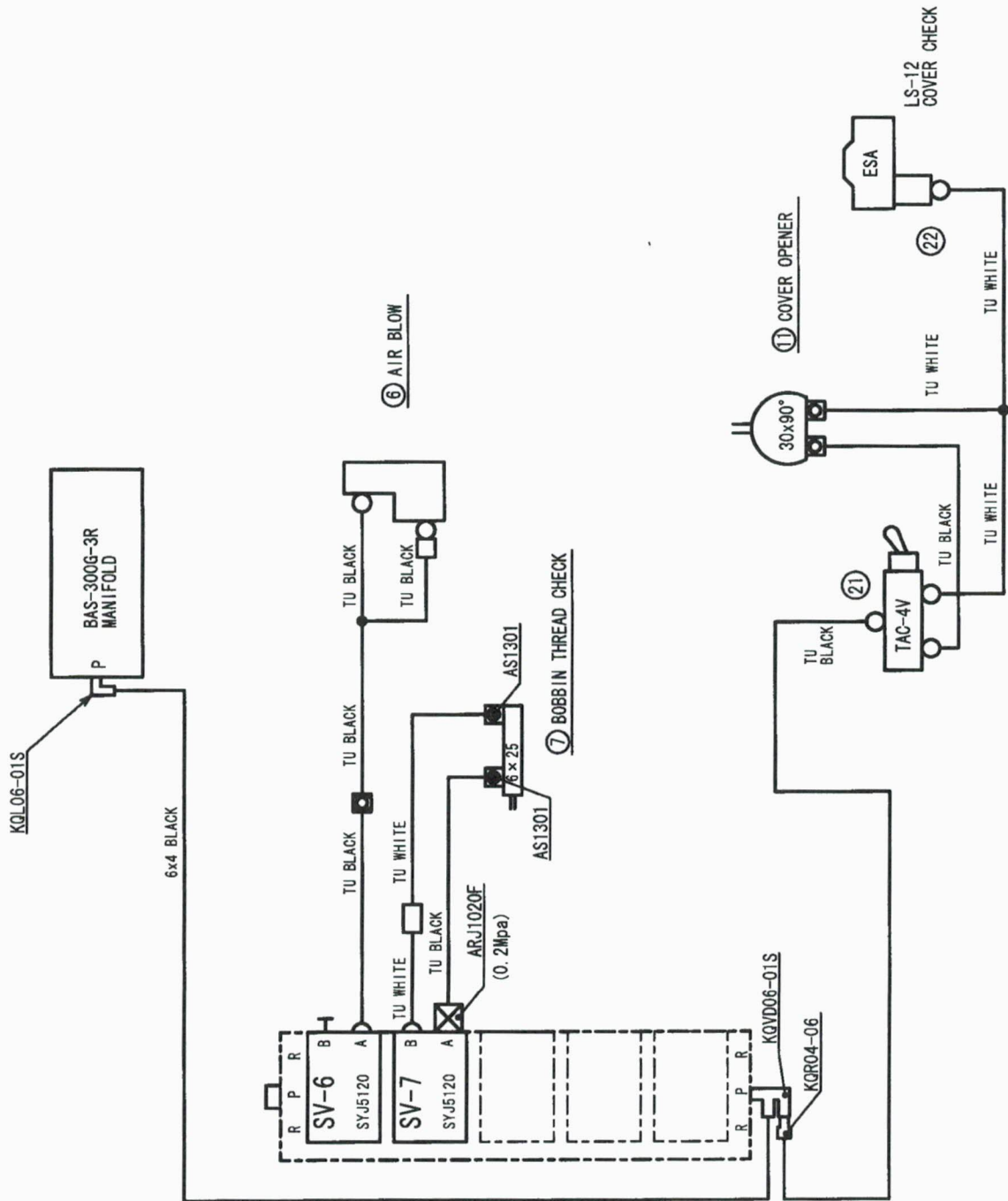

### (3) Positioning of skipping stitch detective device and bobbin rotation detective device

#### 1) Positioning of each devices

Blow up the air.

After that, pick up the opening -closing selector lever ① and move the sensor base ②

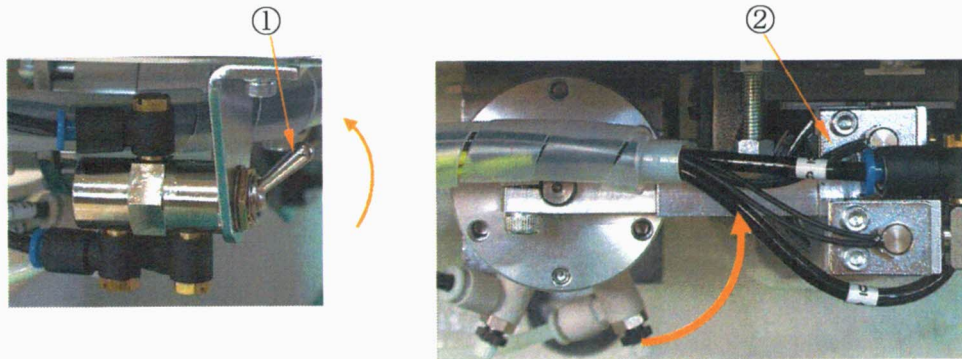

Then the gap width between sensor base ② and bobbin case ④ should be  $6 \pm 0.5\text{mm}$ .  
(Confirm with using of an accessory gap gauge)

And then, holes center ⑧ on the side of bobbin ⑦ should be an extension of the center of bobbin rotation device sensor ⑥.

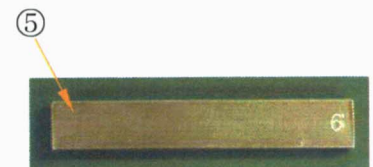
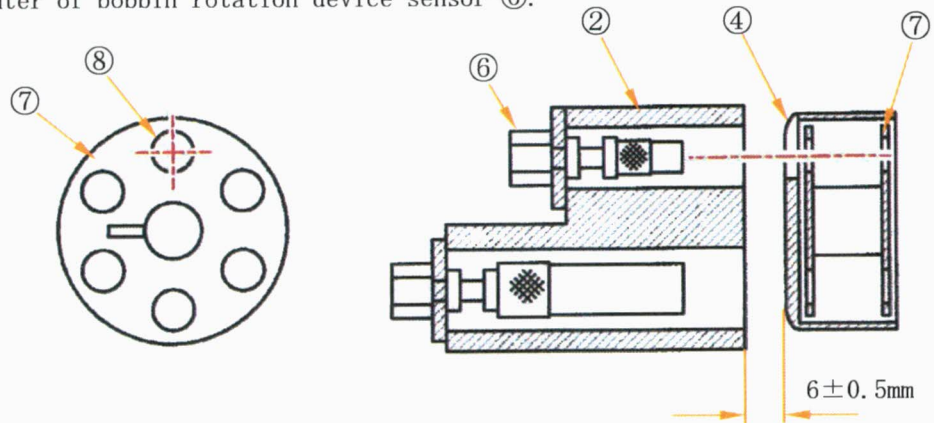

(Thickness 6mm)

Back-forth and vertical positioning ;  
Loosen the screw ⑨ and move the sensor base ②.  
Right and left positioning ; Loosen the screw ⑩  
and move the rotor base ⑪.

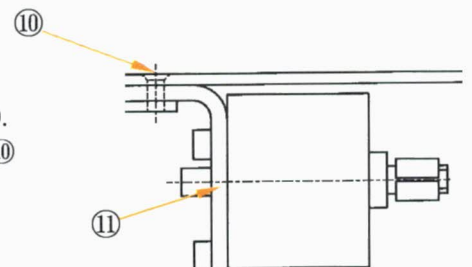

## 2) Sensitivity adjustment

### I) Sensitivity adjustment of skipping detective sensor

Sensitive adjustment of skipping stitch detective sensor amplifier ⑧ should be effective by manual button ⑨.

Set the setting value 1/2 of indicating current value that in the condition of closed hook cover within bobbin case.

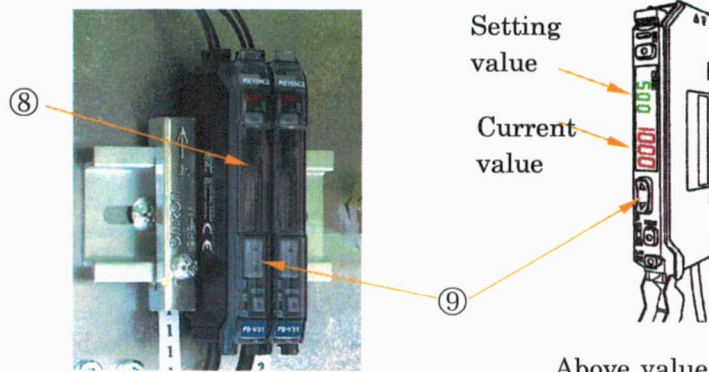

Above values are examples only

### II) Sensitive adjustment of bobbin rotation detective sensor

Sensitive adjustment of bobbin rotation detective sensor amplifier ⑩ should be effective by manual button ⑪.

Set the setting value add [ 150 ] on the indicating current value that in the condition of closed hook cover without bobbin case.

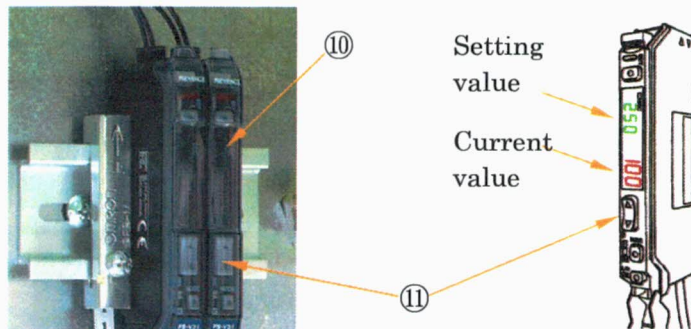

Above values are examples only



(4) Positioning of bobbin thread remaining detective device

1) Positioning

The rod center axis ① should be an extension of bobbin case side hole center ②. Also, the distance between the center of bobbin case ③ and rod apex ① should be  $27.5\text{mm} \pm 1\text{mm}$

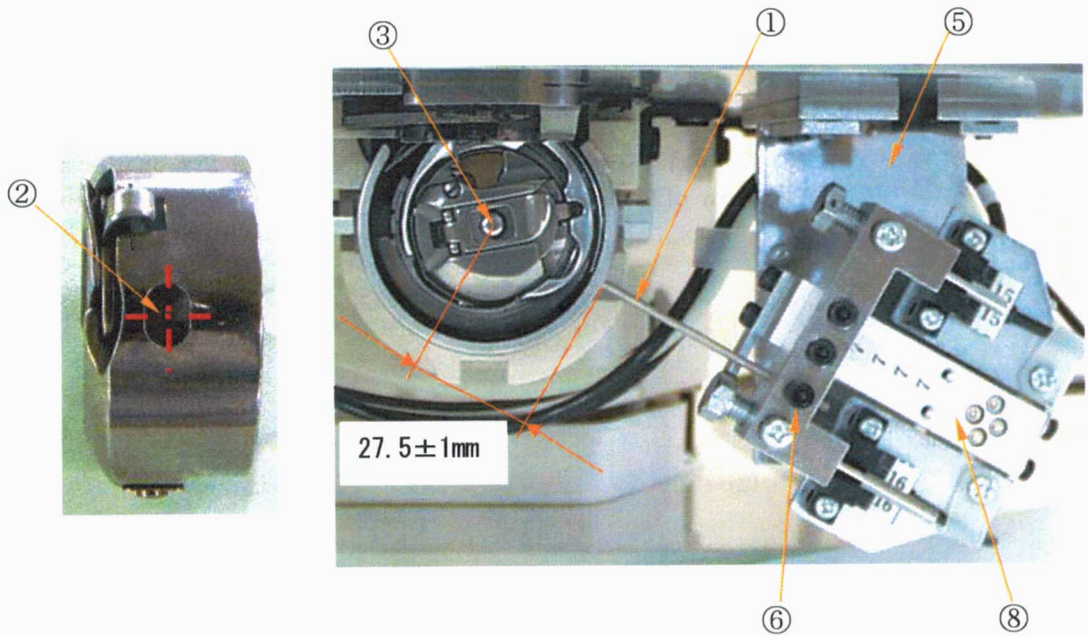

Back-forth positioning ; Loosen the screw ④ and move the device base ⑤.  
Right-Left positioning ; Loosen the screw ⑥ and move the rod ①.  
Up-down positioning; Loosen the screw ⑦ and move the cylinder ⑧.

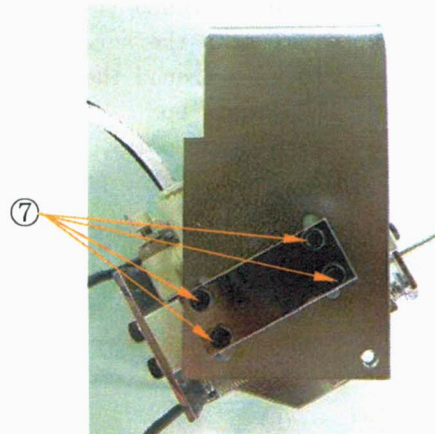
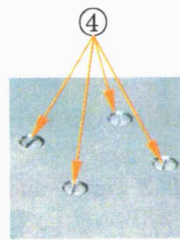

## 2) Sensitivity adjustment

### I) Adjustment of bobbin loading verification sensor ①

- i) Insert a bobbin case incompletely to the hook.
- ii) Blow up the air
- iii) Turn on the power switch with step on the presser plate lifting pedal.  
Then, confirm the rod ③ proceeds to bobbin case ② and stop its motion after touch it.
- iv) Loosen the screw ④.
- v) Turn around the bolt ⑤ and stop it at the point of the sensor lamp ⑥ lights up.
- vi) Give the screw ⑤ another turn once and fix up the screw ④.
- vii) Turn off the power and remove a bobbin case and reload it normally.

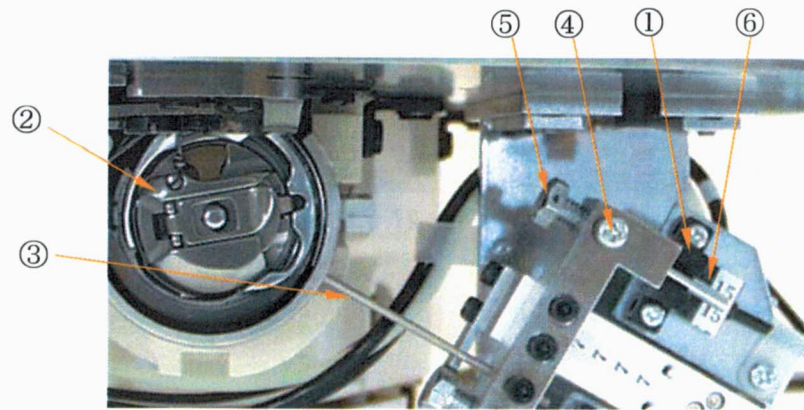

### II) Adjustment of bobbin thread remaining amount detective sensor.

- i) Load the bobbin case ⑧ normally within an empty bobbin.
- ii) Blow up the air.
- iii) Turn on the power switch with step on the presser plate lifting pedal.  
Then, confirm the rod ③ proceeds to bobbin case ② and stop its motion after touch it automatically.
- iv) Loosen the screw ⑩
- v) Turn around the bolt ⑪ and stop it at the point of the sensor lamp ⑫ lights up.
- vi) At this point, loosen the screw ⑪ 2-turns and fix up the screw ⑩.
- vii) Turn off the power

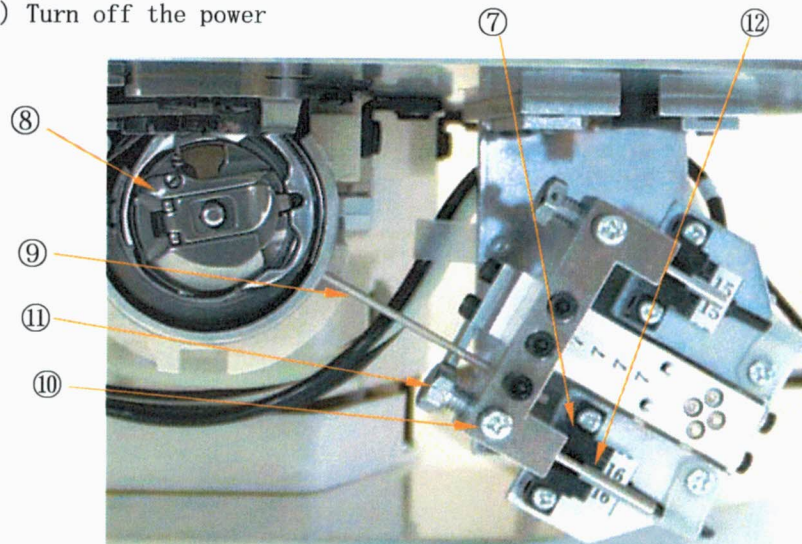

(5) Machine Control Program Updating

To make sure that all function effectively, it is necessary to update the Bbrother control program.

Update as follows.

- 1) Insert the CF card.

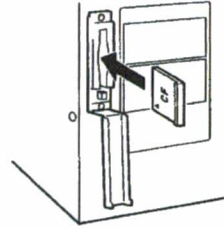

- 2) Turn power on.

- 3) Enter updating mode  
Press R/W button while pressing TEST button.

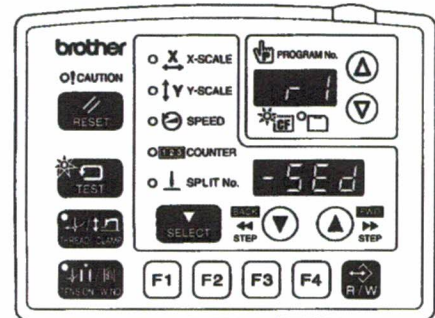

- 4) Press  $\Delta$  button or  $\nabla$  button to choose updating mode 「r7」.

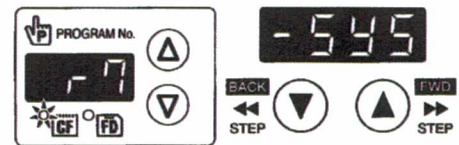

- 5) Press R/W button.  
Updating is in operation when program No. are displayed on [ P ] with blinking.

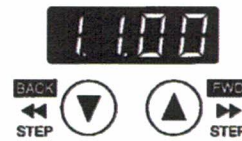
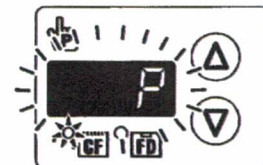

- 6) While [End] displayed, updating accomplishes.  
turn power off, take off CF card and lock the card slot.

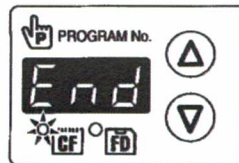

(Caution) Please refer to adjustment manual for more details.

## 2. minor adjustment of detection sensor

### (1) Skipping stitch detective sensor

In case of [NEEDLE THREAD] lamp lights up without no skipping stitch and machine is suspended, decrease the setting value little more.  
(around 20 at one time)

Moreover, in order to prevent the sensor glitch, clean up a bobbin case with duster before start operation everyday.

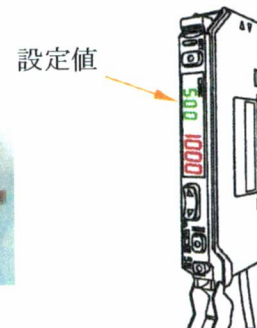

### (2) Bobbin rotation detective sensor

Although bobbin thread is consuming, [BOBBIN THREAD] lamp lights up and the machine is suspended, increase the setting value little more.  
(around 50 at one time)

Even through, bobbin thread is not consumed and the machine does not suspend,  
(even [BOBBIN THREAD] lamp does not light up, too),  
decrease the setting value little bit a time.  
(around 50 at one time)

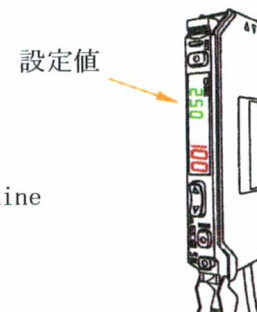

(3) Bobbin loading verifying sensor

Though bobbin case defectively loaded, [BOBBIN THREAD] lamp is not blinking, loosen the screw ① and tighten up the screw ②.

(Do not turn around a lot at once, around 30 degrees at the time.)

Even though bobbin case normally loaded, [BOBBIN THREAD] lamp is blinking, loosen the screw ① and loosen the screw ②.  
(Do not turn around a lot at once, around 30 degrees at the time.)

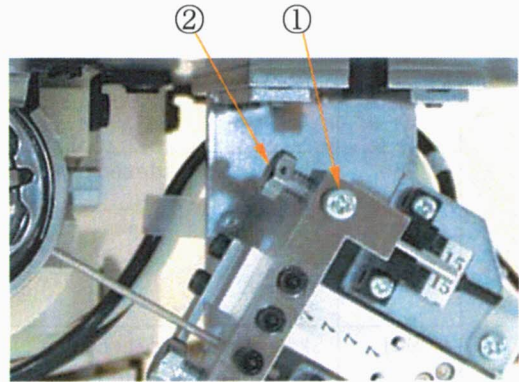

(4) Bobbin thread remaining amount detective sensor

Though bobbin thread is remaining, [BOBBIN THREAD] lamp is blinking, loosen the screw ③ and tighten up the screw ④.  
(Do not turn around a lot at once, around 30 degrees at the time.)

Even though bobbin is empty of thread, [BOBBIN THREAD] lamp is not blinking, loosen the screw ③ and loosen the screw ④.  
(Do not turn around a lot at once, around 30 degrees at the time.)

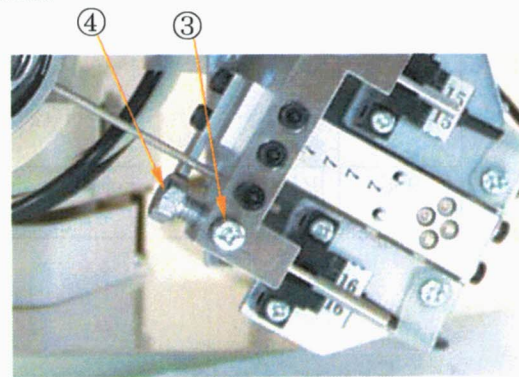

### 3. Memory Switch

Number	Content	Setting Range	Initial Value
960	Skip stitch detection sensor amplifier	0 : Function disabled 1 : Stops when first stitch skips 2 : Stops when first 2 stitches skip	1
961	Skip stitch detection : the uncounting stitches at beginning	0~10[stitch]	3
962	Bobbin rotation detection sensor amplifier	0 : Function disabled 1~30[stitch]	15
963	Bobbin rotation detection sensor : the uncounting stitches at beginning	0~30[stitch]	10
964	Bobbin thread remains detection time	0 : Function disabled 1 : Before sewing 2 : After sewing 3 : Before and after sewing	2
965	Bobbin thread remains detection : detection time	20~40[×10msec]	30

### 4. Error Code

Number	Content	reset
E605	Skip stitch error	Same as STOP SW operation
E615	Bobbin rotation error	Same as STOP SW operation
E625	Bobbin inserting error	Push RESET SW
E626	Sensor covered is opened	Let go the start pedal
E627	Sensor covered opened during sewing	Power OFF
E628	Bobbin thread detectionsensor error	Power OFF
E629	Bobbin thread detection rod return error	Power OFF
---	Out of thread	Wind thread on the bobbin

(caution) follow the steps to restart the machine when it is stoped under error conditions.

- 1) press RESET button.
- 2) press RESET button again.
- 3) step on the foot pedal to start the machine.
- 4) machine gets back to origin, and presser foot ups.

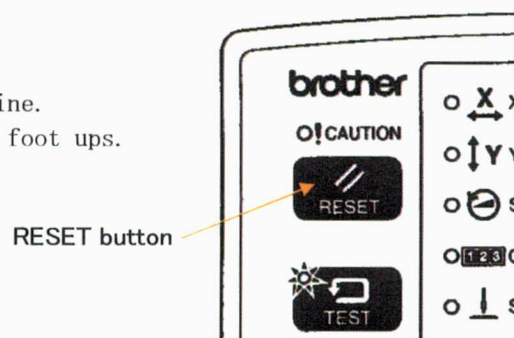

## 5. Device Mechanism

Fig 6 holes② on bobbin①, and when the holes match with sensor③, it will be recognized that beeing rotation.

As the bobbin is not in rotation when bobbin thread is not coming up(skip stitch), sensor would recognize it ,and in the control box a few sewings will be calculated, then the skip stitch alarm would be announced and the machine stops.

