

FB-N210

パーツブック
PARTS BOOK

超高速2本縫オーバーロックミシン

HIGH SPEED TWIN NEEDLE OVERLOCK SEWING MACHINE

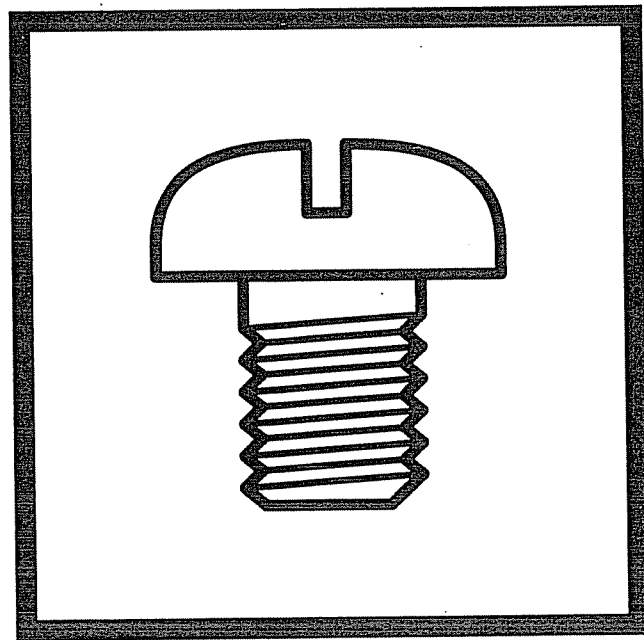

3

4

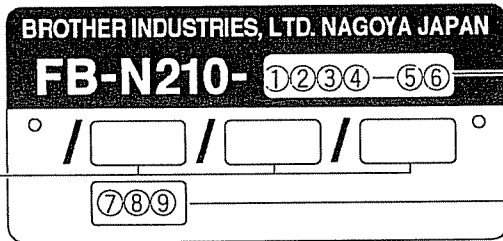

装置 / Devices

仕様 / Specifications

仕様明細 / Detail of specifications

①

縫い目形式 / Stitch form	
W	2本針縁かがり・2本掛け Twin needle over-edge chain stitch, standard stitch
M	2本針縁かがり・1本外し Twin needle over-edge chain stitch, mock safety stitch

⑥

かがり幅 / Stich width	
2	2 mm
3	3 mm
4	4 mm
5	5 mm
6	6 mm
7	7 mm

②

用途 / Applications	
0	地縫い / Plain seaming
4	ひだ取り / Ruffling
5	テープ付け / Taping
6	パイピング付ひだ取り / Ruffling with piping
8	バックタック / Back tacking

⑦

上ルーバリフト / Over-looper locus	
S	スタンダード / Standard lift
H	ハイリフト / High lift
E	超ハイリフト / Extra high lift

③

縫製物 / Sewing materials	
1	極薄物～薄物 / Extra light - light materials
2	薄物～中厚物 / Light - medium materials
3	中厚物～厚物 / Medium - heavy materials
4	厚物～極厚物 / Heavy - Extra heavy materials
5	極厚物 / Extra heavy materials
6	バルキーニット / Bulky knit
7	極厚バルキーニット / Extra heavy bulky knit

⑧

差動送り歯 / 針板チェンランド / Differential feed dog	
2	2列標準 / チェンランドあり 2-row standard / with chain land
3	3列標準 / チェンランドあり 3-row standard / with chain land
4	4列標準 / チェンランドあり 4-row standard / with chain land
7	2列標準 / チェンランドなし 2-row standard / without chain land
8	3列標準 / チェンランドなし 3-row standard / without chain land
9	4列標準 / チェンランドなし 4-row standard / without chain land

④

特殊用途 / Special use	
0	標準 / Standard
1	小回り仕様 / Small type
S	セミオートバックタック / Semi auto backtack

⑨

上メス形状 / Upper knife shape	
F	平メス / Flat knife
A	角メス / Angle knife
B	角メス幅広 / Angle knife, wide
V	角メス波刃 / Angle knife, wave shape
W	角メス幅広波刃 / Angle knife, wave shape

⑤

針幅 / Needle gauge	
2	2.2mm
X	2.5mm
3	3mm

パーツブックご利用に際して

1. この本は、2001年12月のデータに基づいて作成されたものです。
2. 部品は予告なしに設計変更される場合があります。
3. 組単位で補給する部品は、 破線で示してあります。
4. 部品コード欄が*となっている場合は、ゲージ部品一覧表(43~47ページ)でお調べ下さい。

目 次

A.	フレーム関係	1
B.	駆動軸関係	5
C.	針棒関係	7
D.	針冷却関係	9
E.	縁カガリ定規関係	9
F1.	押工関係	11
F2.	押工関係	13
G.	送り関係	17
H.	上メス・下メス関係	21
J.	バックタック関係	23
K.	上ルーパ関係	25
L.	下ルーパ関係	27
M.	給油潤滑関係	29
N.	糸調子関係	31
P1.	ラフラー装置関係	33
P2.	ラフラー装置関係	35
P3.	ラフラー装置関係	37
Z1.	付属品関係	39
Z2.	付属品関係 (オプションパーツ)	41
Ga1.	ゲージ部品一覧表	43
Ga2.	ゲージ部品一覧表	44
Ga3.	ゲージ部品一覧表	45
Ga4.	ゲージ部品一覧表	46
Ga5.	ゲージ部品一覧表	47
Wa.	警告ラベル	

Notes for using this parts book

1. This book was prepared based on information available in December 2001.
2. Parts are subject to changes in design without prior notice.
3. Parts supplied as complete assemblies are circled by a dotted line [].
4. If the symbol * is found in the " Parts No." column, refer to the gauge parts list on page 43~47.

CONTENTS

A.	Machine body.	1
B.	Crankshaft mechanism.	5
C.	Needle bar mechanism.	7
D.	Needle cooler.	9
E.	Serging attachment.	9
F 1.	Presser foot mechanism.	11
F 2.	Presser foot mechanism	13
G.	Feed mechanism.	17
H.	Knife mechanism.	21
J.	Back-tacking.	23
K.	Over looper mechanism.	25
L.	Under looper mechanism.	27
M.	Lubrication.	29
N.	Thread tension.	31
P 1.	Ruffling attachment.	33
P 2.	Ruffling attachment.	35
P 3.	Ruffling attachment.	37
Z 1.	Accessories.	39
Z 2.	Accessories (Option parts).	41
G a1.	Gauge parts List.	43
G a2.	Gauge parts List.	44
G a3.	Gauge parts List.	45
G a4.	Gauge parts List.	46
G a5.	Gauge parts List.	47
Wa.	Warning labels	

A. フレーム関係 / Machine body

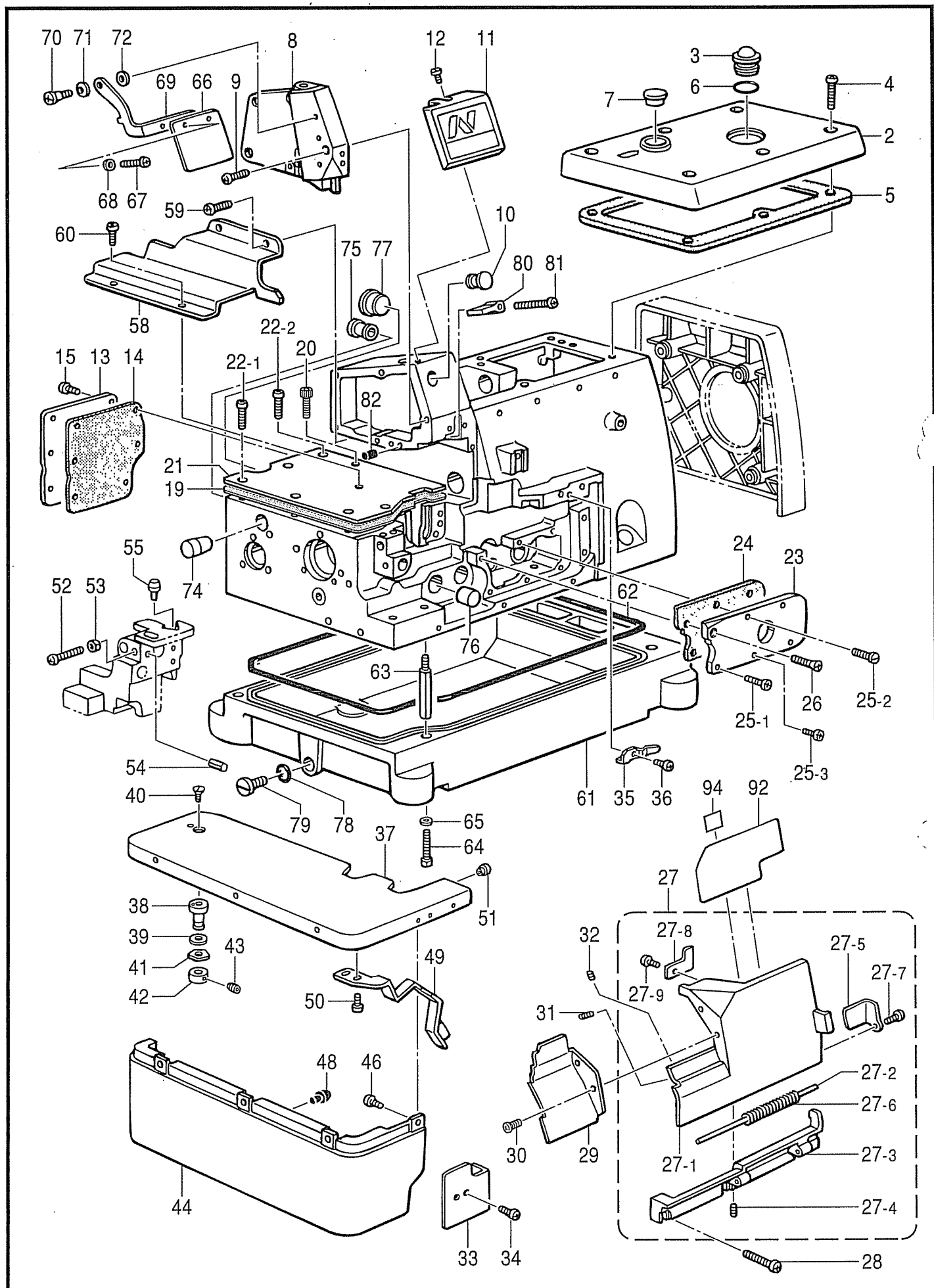

A. フレーム関係 / Machine body

REF.NO	CODE	Q'TY	ヒンメイ	NAME OF PARTS	RM
2	S39605001	1	ウツカハ	TOP COVER	
3	S02606020	1	ユリヨウケイマ	OIL GAUGE WINDOW	
4	062401012	6	ナヘコM4X10	SCREW, PAN M4X10	
5	S39606020	1	ハツキン	PACKING	
6	081014670	1	リングPW14	O RING, PW14	
7	S23337001	1	ゴムセン18.5	RUBBER CAP, 18.5	
8	S39607001	1	ソクメンカハ	SIDE COVER, FRAME	
9	062400812	5	ナヘコM4X8	SCREW, PAN M4X8	
10	S20345001	1	ゴムセン14	RUBBER CAP, 14	
11	S39608021	1	メンイタカハ	FACE PLATE COVER	
12	060400612	1	ハイントM4X6	SCREW, BIND M4X6	
13	S20310001	1	オクリキコウカハ-B	COVER, B ;FEED MECHANISM	
14	S20311000	1	ハツキン	PACKING	
15	060400812	6	ハイントM4X8	SCREW, BIND M4X8	
19	S44778000	1	オクリタイカハ-Hツキン	PACKING, FEED BAR	
20	018400832	1	アナホルルトM4X8	BOLT, SOCKET M4X8	
21	S44779001	1	オクリタイカハ	FEED BAR COVER	
22-1	060400812	5	ハイントM4X8	SCREW, BIND M4X8	
22-2	S44535001	1	ハイントM4X8シール	SCREW, BIND M4X8 SEAL	
23	S39564021	1	ウチカハ	INSIDE COVER	
24	S44536000	1	ウチカハ-Hツキン	PACKING, INSIDE COVER	
25-1	060401012	3	ハイントM4X10	SCREW, BIND M4X10	
25-2	S23616101	1	シメネジM4X10	SCREW, M4X10	
25-3	S44535001	1	ハイントM4X8シール	SCREW, BIND M4X8 SEAL	
26	061400812	1	サラコM4X8	SCREW, FLAT M4X8	
27	S39611001	1	マエカハ-Lクミ	FRONT COVER ASSY, L	
27-1	S39612001	1	マエカハ-L	FRONT COVER, L	
27-2	S39613001	1	マエカハ-ヒンシツク	HINGE SHAFT, FRONT COVER	
27-3	S20319001	1	マエカハ-ヒンシ	HINGE, FRONT COVER	
27-4	012400432	2	アナヒラM4X4	SET SCREW, SOCKET (FT) M4X4	
27-5	S20320101	1	マエカハ-ストツハ	STOPPER, FRONT COVER	
27-6	S20321001	1	マエカハ-ハネ	SPRING, FRONT COVER	
27-7	060400612	1	ハイントM4X6	SCREW, BIND M4X6	
27-8	S20327101	1	マエカハ-トメイタ	STOPPER PLATE, FRONT COVER	
27-9	060400612	1	ハイントM4X6	SCREW, BIND M4X6	
28	060401412	3	ハイントM4X14	SCREW, BIND M4X14	
29	S38304001	1	マエカハ-S	FRONT COVER, S	
30	062400612	2	ナヘコM4X6	SCREW, PAN M4X6	
31	012400832	1	アナヒラM4X8	SET SCREW, SOCKET (FT) M4X8	
32	012400432	1	アナヒラM4X4	SET SCREW, SOCKET (FT) M4X4	
33	S20324101	1	マエカハ-Lアンナイ	GUIDE, L F-VOVER	
34	060400612	2	ハイントM4X6	SCREW, BIND M4X6	
35	S20325001	1	マエカハ-トメイタハネ	SPRING, PLATE	
36	060400612	1	ハイントM4X6	SCREW, BIND M4X6	
37	S39562001	1	クロスプレート	CLOTH PLATE	
38	S39623001	1	クロスプレートササシツク	CLOTH PLATE SHAFT	
39	141183000	1	クロスプレートシート	CLOTH PLATE SHEET	
40	100032003	1	サラネジ4.37	SCREW, FLAT SM4.37-40X8	
41	100315002	1	ナミハネ	WASHER	
42	S39624021	1	セットカラー	SET SCREW COLLAR	
43	012060632	2	アナヒラM6X6	SET SCREW, SOCKET (FT) M6X6	
44	S38301020	1	クロスプレートシタ	CLOTH PLATE, LOWER	
46	060400612	4	ハイントM4X6	SCREW, BIND M4X6	
48	S20412000	2	ゴムセン3.7	RUBBER CAP, 3.7	
49	S39625151	1	クロスプレートトメイタハネ	SPRING, PLATE	
50	060400612	2	ハイントM4X6	SCREW, BIND M4X6	
51	156482000	1	セン4	CAP, 4	
52	062401212	1	ナヘコM4X12	SCREW, PAN M4X12	
53	021400212	1	2シユナツト4	NUT, 2 M4	
54	047602042	1	スプリングピン6X20	PIN, SPRING ROLL 6X10	
55	S20412000	1	ゴムセン3.7	RUBBER CAP, 3.7	

A. フレーム関係 / Machine body

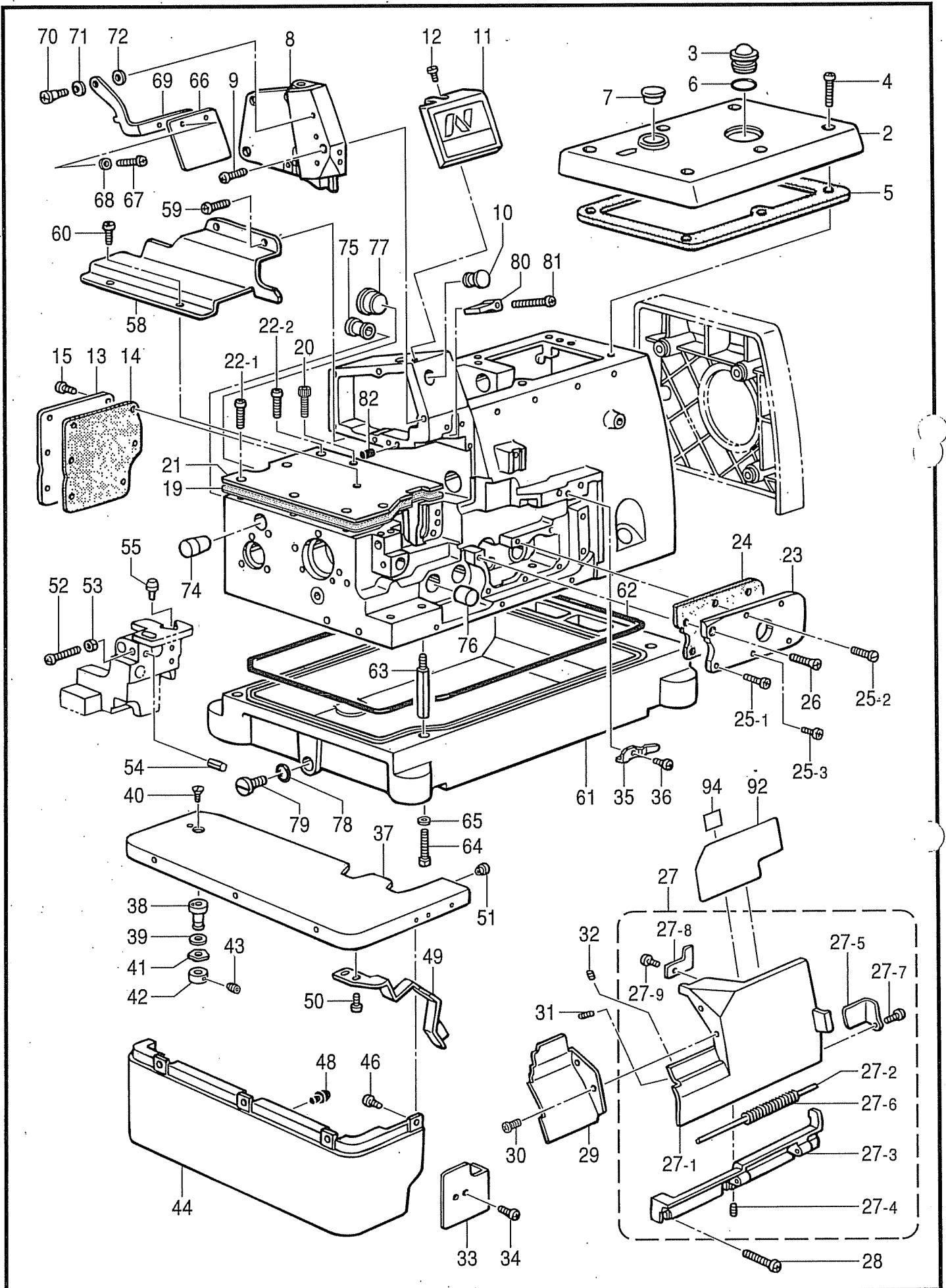

A . フレーム関係 / Machine body

REF.NO	CODE	Q'TY	ヒンメイ	NAME OF PARTS	RM
58	S39626021	1	クロスプレートノアンナイ	CLOTH GUIDE	
59	060400612	2	バインド M4X6	SCREW, BIND M4X6	
60	060400512	1	バインド M4X5	SCREW, BIND M4X5	
61	S20338200	1	アブラウケ	OIL PAN	
62	S20339000	1	パッキン	PACKING	
63	S23350001	4	ホントイシユウ	MACHINE BODY LEG	
64	017501212	4	ボルト5X12	BOLT, M5X12	
65	S23351001	4	ワッシャー	WASHER	
66	S00075000	1	アイガード	EYE GUARD	
67	060350812	2	バインド M3.5X8	SCREW, BIND M3.5X8	
68	025350332	2	ワッシャー平 L 3.5	WASHER, PLAIN L 3.5	
69	S20340001	1	アイガードササエ	EYE GUARD SUPPORT PLATE	
70	S20342001	1	タネシ 4	SHOULDER SCREW, M4	
71	146598001	1	ワッシャーボウルスプリング	WASHER, BOWL SPRING	
72	025050132	1	ワッシャー平 S 5	WASHER, PLAIN S 5	
74	S20344001	1	ゴムセン 16	RUBBER CAP, 16	
75	S20345001	1	ゴムセン 14	RUBBER CAP, 14	
76	154841001	1	ゴムセン 16.8	RUBBER CAP, 16.8	
77	S23337001	1	ゴムセン 18.5	RUBBER CAP, 18.5	
78	081009070	1	Oリング P9	O RING P9	
79	S23357001	1	シメシメ 10	SCREW, M10	
80	S20346000	1	ハリホウアブラウケ	OIL RESERVOIR, N-BAR	
81	062401612	1	ナット M4X16	SCREW, PAN M4X16	
82	S20878000	1	ゴムセン 5.3	RUBBER CAP, 5.3	
92	S39784001	1	イトボシセツメイラベル C	THREADING DIAGRAM LABEL, D	
94	S44821001	1	セイノウシラベル	LABEL, CLEANING	

B. 駆動軸関係 / Crankshaft mechanism

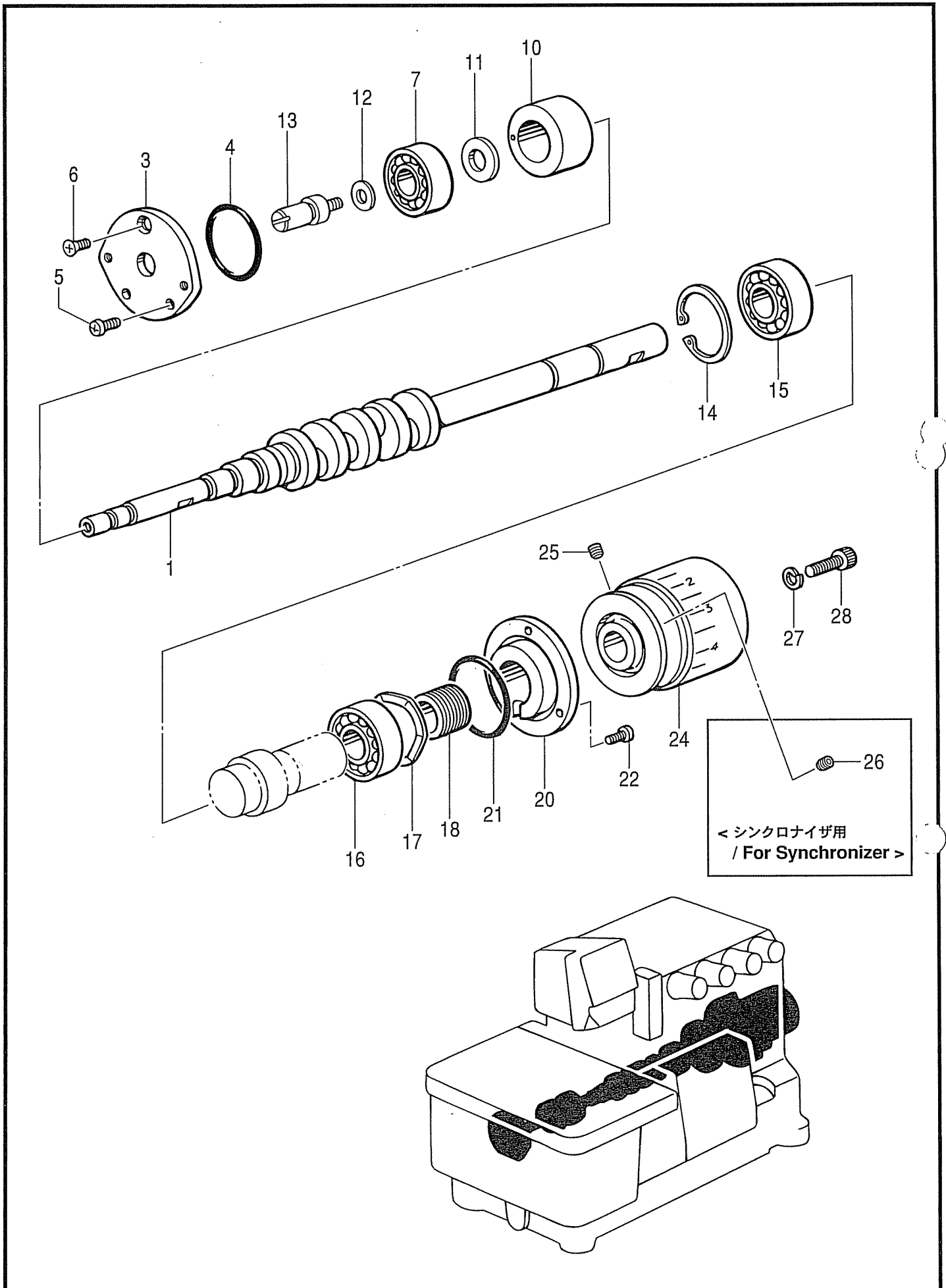

B. 駆動軸関係 / Crankshaft mechanism

REF.NO	CODE	Q'TY	ヒンメイ	NAME OF PARTS	RM
1	S54001001	1	<ハイリフト用> クランクシャフトR	<For High lift> CRANKSHAFT, R	
1	S54002001	1	<超ハイリフト用> クランクシャフトS	<For Extra high lift> CRANKSHAFT, S	
3	S39629021	1	ベアリングカバー	BEARING CAP	
4	081031870	1	Oリング S31.5	O RING, S31.5	
5	062400812	2	ナットM4X8	SCREW, PAN M4X8	
6	061400812	1	フラットヘッドM4X8	SCREW, FLAT M4X8	
7	072600000	1	ボールベアリング6000	BALL BEARING, 6000	
10	S39630000	1	クランクシャフトブッシュ	BUSH, CRANKSHAFT	
11	S20356001	1	ワッシャー10	WASHER, PLAIN 10	
12	155559001	1	ワッシャー	WASHER, PLAIN	
13	S46900001	1	ニードルテンションシャフト	SHAFT, D/C STITCH THR/TAKE-UP	
14	048400242	1	トリマリングC40	RETAINING RING, INTERNAL C40	
15	076203000	1	ボールベアリング6203	BALL BEARING, 6203	
16	S27868001	1	ボールベアリング6203V	BALL BEARING, 6203V	
17	S20361001	1	波板バネ	SPRING, WAVE	
18	S20362151	1	クランクシャフトオイルリキッド	OIL REJECTOR, CRANKSHAFT	
20	S39631000	1	ベアリングホルダー	HOLDER, BEARING	
21	S20353000	1	Oリング	O RING	
22	062401012	3	ナットM4X10	SCREW, PAN M4X10	
24	S39775001	1	プーリー	PULLEY	
24	S39565101	1	<シンクロナイザー用> プーリー	<For Synchronizer> PULLEY	
26	012060632	1	アジャスターM6X6	SET SCREW, SOCKET (FT) M6X6	
25	012060632	1	アジャスターM6X6	SET SCREW, SOCKET (FT) M6X6	
27	028060242	1	バネワッシャー2-6	WASHER, SPRING 2-6	
28	018062532	1	ボルトM6X25	BOLT, SOCKET M6X25	

C. 針棒關係 / Needle bar mechanism

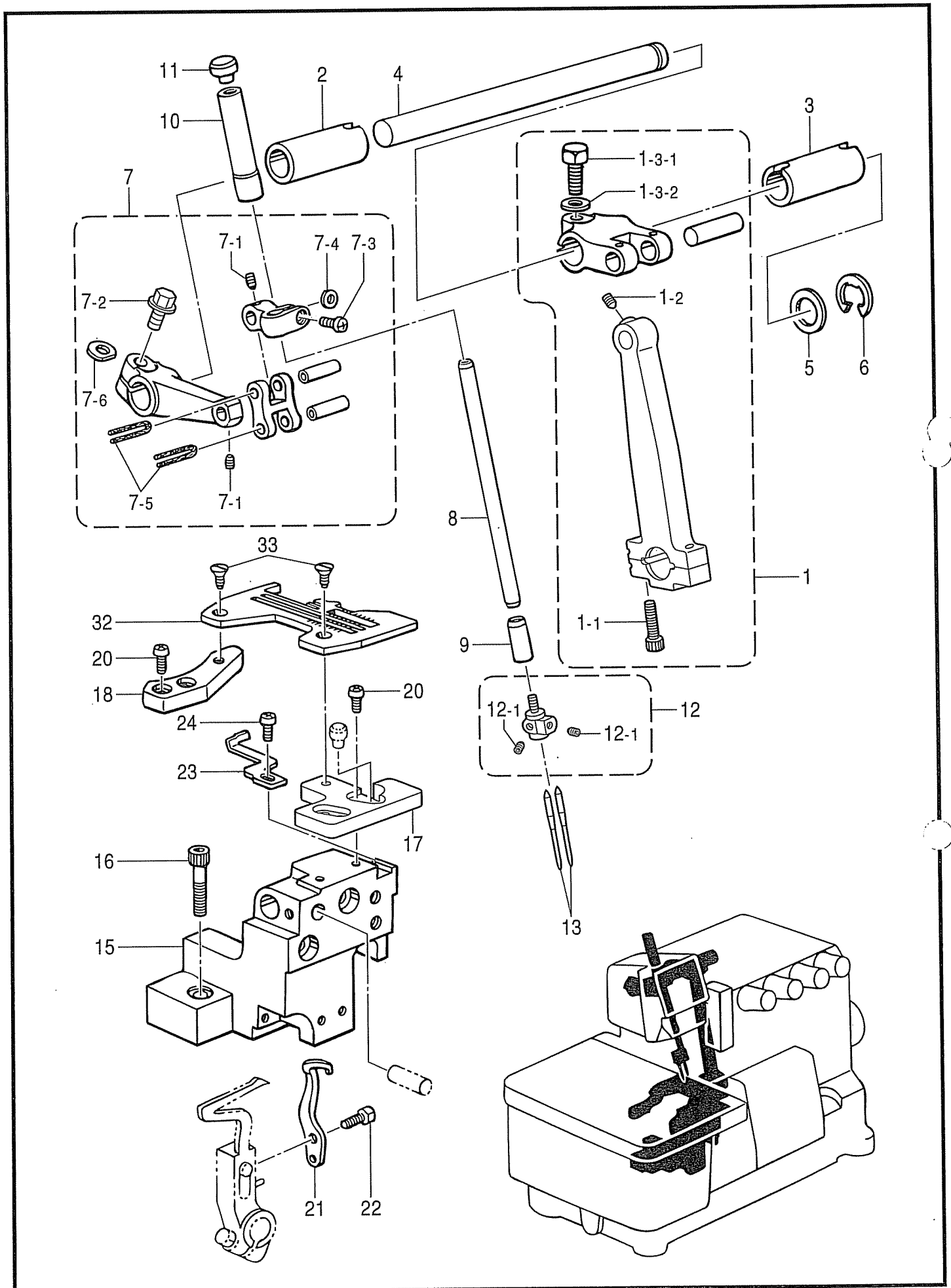

C. 針棒関係 / Needle bar mechanism

REF.NO	CODE	Q'TY	ヒンメイ	NAME OF PARTS	RM
1	S54006001	1	<ハイリフト用> ハリクランクロッドクミ	<For High lift> NEEDLE D/CRANK ROD ASSY, H	
1	S54007001	1	<超ハイリフト用> ハリクランクロッドクミ	<For Extra high lift> NEEDLE D/CRANK ROD ASSY, E	
1-1	018401622	2	アナホルト4X16	BOLT, SOCKET M4X16	
1-2	S23342001	1	アナトガリ4X5	SET SCREW, SOCKET (CN) M4X5	
1-3-1	017061612	1	ホルト6X16	BOLT, M6X16	
1-3-2	118735002	1	サガネ	WASHER, PLAIN	
2	S39644021	1	ハリシクメタルL	BUSH, L ;NEEDLE SHAFT	
3	S39645021	1	ハリシクメタルR	BUSH, R ;NEEDLE SHAFT	
4	S39646021	1	ハリシク	NEEDLE SHAFT	
5	S39647000	1	サガネ	WASHER	
6	146293001	1	トメ7E10	RETAINING RING, E10	
7	S39566001	1	ハリホウダキミ	NEEDLE BAR CLAMP ASSY	
7-1	S23342001	2	アナトガリ4X5	SET SCREW, SOCKET (CN) M4X5	
7-2	S46899001	1	サガネツキホルト6X16	BOLT, (W/WASHER) M6X16	
7-3	062350812	1	ナホコ3.5X8	SCREW, PAN M3.5X8	
7-4	S20391001	1	スハサ	SPACER	
7-5	S20392000	2	フェルト	FELT	
7-6	155162001	1	スハサ	SPACER	
8	S39574001	1	ハリホウ	NEEDLE BAR	
9	S39648021	1	ハリホウメタルD	BUSH, D ;NEEDLE BAR	
10	S39571021	1	ハリホウメタルU	BUSH, U ;NEEDLE BAR	
11	104450101	1	ゴムセン8	RUBBER CAP, 8	
12	*	1	ハリトメ2.2クミ	NEEDLE CLAMP ASSY, 2.2	
12-1	146427001	2	アナトメネシ3.18クホミ	SET SCREW, SOCKET (CP) SM3.18	
13	*	2	ミシンハリDCX27	NEEDLE, DCX27 (#7)	
15	S39649021	1	ハリタササエイ	SUPPORT BRACKET, N-PLATE	
16	018062532	2	アナホルト6X25	BOLT, SOCKET M6X25	
17	S39650051	1	ハリタササエイF	NEEDLE PLATE SUPPORT, F	
18	S39652021	1	ハリタササエイB	NEEDLE PLATE SUPPORT, B	
20	062401012	4	ナホコM4X10	SCREW, PAN M4X10	
21	S20415101	1	イトウハリウケ	NEEDLE GUARD, MOVABLE	
22	S20416101	1	ホルト3.5X10	BOLT, M3.5X10	
23	S39653051	1	ハリウケF	NEEDLE GUARD, F	
24	062350812	1	ナホコ3.5X8	SCREW, PAN M3.5X8	
32	*	1	ハリタ	NEEDLE PLATE	
33	100032003	2	サラネシ4.37	SCREW, FLAT SM4.37-40X8	

D. 針冷却関係 / Needle cooler

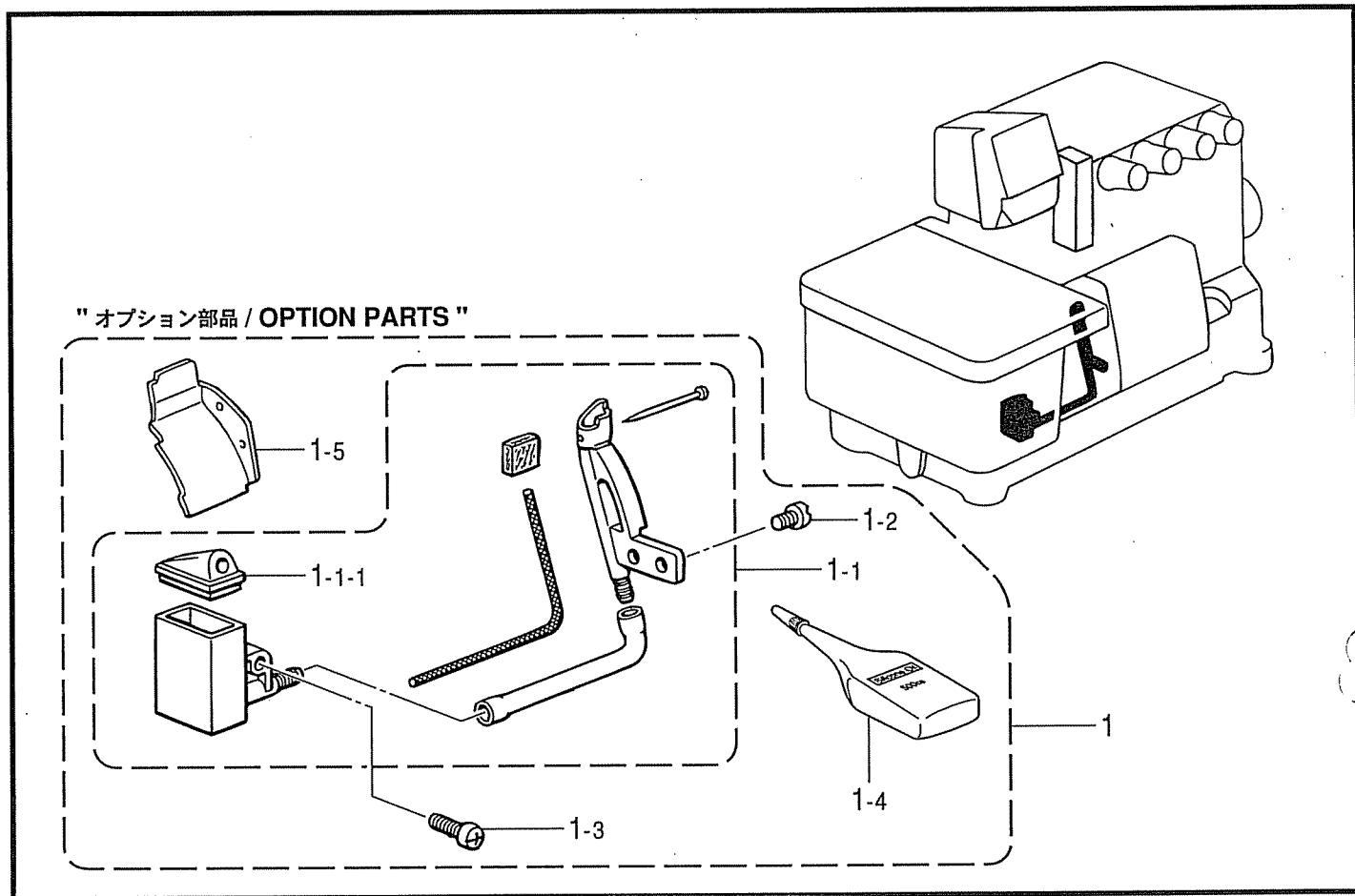

878-N21-124

E. 縁カガリ定規関係 / Serging attachment

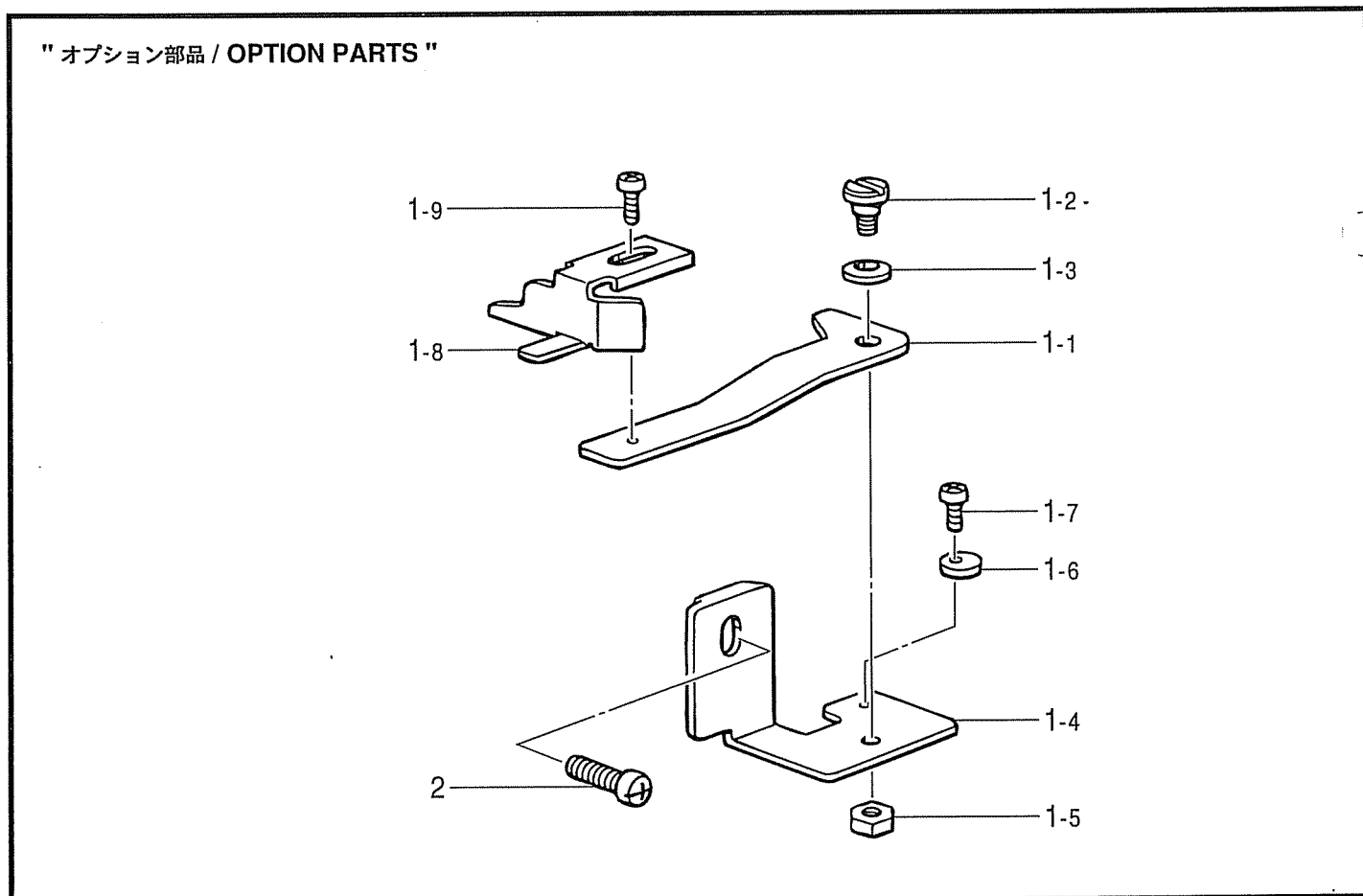

878-N21-236

D. 針冷却関係 / Needle cooler

REF.NO	CODE	Q'TY	ヒンメイ	NAME OF PARTS	RM
1	S43524001	1	” オプション部品” ハリレキヤケツト0	"OPTION PARTS" NEEDLE COOLER SET, O	
1-1	S20453001	1	フェルトサエクミ	FELT SUPPORT ASSY	
1-1-1	S20460000	1	シリコンタンク7タ	CAP, SILICONE TANK	
1-2	S23418002	2	シメネジ 4X5	SCREW, M4X5	
1-3	060401012	1	バインド M4X10	SCREW, BIND M4X10	
1-4	S06704001	1	シリコンオイル	SILICONE OIL	
1-5	S20323101	1	マイカバー-S	FRONT COVER, S	

878-N21-124

E. 縁カガリ定規関係 / Serging attachment

REF.NO	CODE	Q'TY	ヒンメイ	NAME OF PARTS	RM
1	S21336101	1	” オプション部品” フチカガリシヨキクミ	"OPTION PARTS" EDGE GUIDE ASSY	
1-1	S23896101	1	シヨキトリツケイタ	SETTING PLATE, ;EDGE GUIDE	
1-2	S23773001	1	タンネジ 4	SHOULDER SCREW, M4	
1-3	146598001	1	ハネサガネ	WASHER, BOWL SPRING	
-4	S23897001	1	シヨキトリツケイタサエ	EDGE GUIDE SUPPORT	
1-5	021400212	1	2シユツト4	NUT, 2 M4	
1-6	S21341001	1	ストッパー	STOPPER	
1-7	062300512	1	サコ M3X5	SCREW, PAN M3X5	
1-8	146762001	1	フチカガリシヨキ	EDGE GUIDE	
1-9	062350612	1	サコ M3.5X6	SCREW, PAN M3.5X6	
2	062401012	1	サコ M4X10	SCREW, PAN M4X10	

878-N21-236

F1 . 押工関係 / Presser foot mechanism

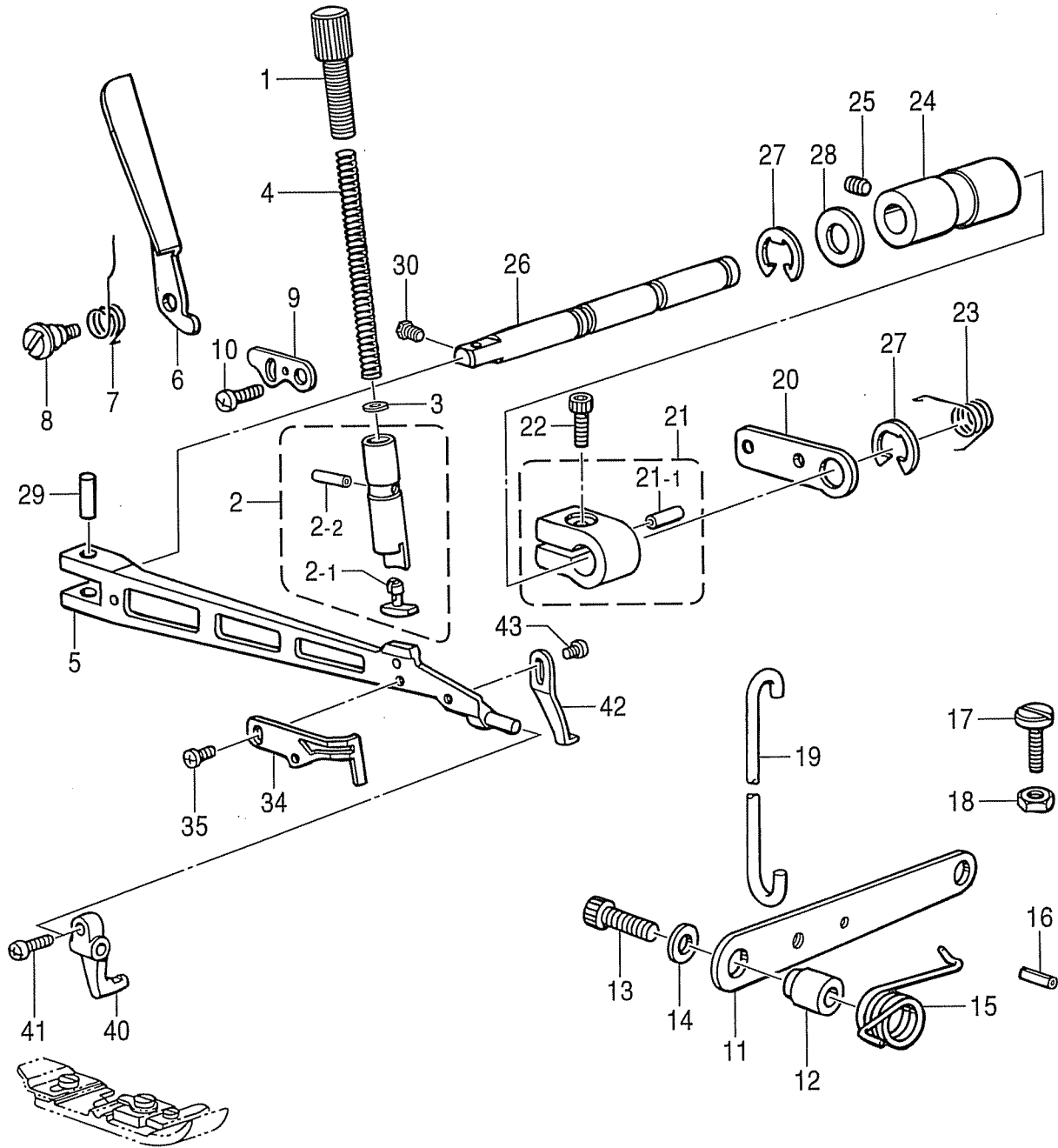

<テーピング用 / For Taping >

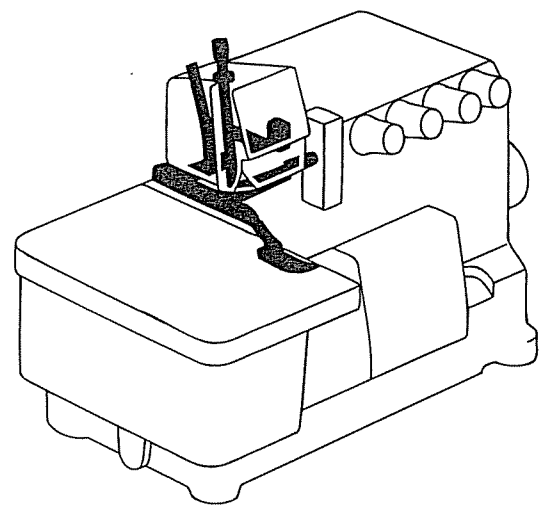
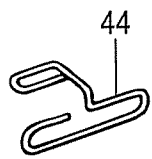

F1. 押工関係 / Presser foot mechanism

REF.NO	CODE	Q'TY	ヒンメイ	NAME OF PARTS	RM
1	S39658001	1	オサエチヨウセツネジ	ADJUSTING SCREW, PRESSER	
2	S39575001	1	オサエホウクミ	PRESSER BAR ASSY	
2-1	S39577000	1	オサイクツシヨシ	CUSHION	
2-2	047301642	1	スプリングピンAW3	SPRING PIN AW3	
3	105161004	1	サカネ	WASHER, PLAIN	
4	S20476001	1	オサエハネ	PRESSER SPRING	
5	S38308121	1	シユオサエウテ	MAIN PRESSER ARM	
6	S39659021	1	オサエテアケ	PRESSER BAR LIFTER	
7	S39660001	1	オサエテアケハネ	SPRING, PRESSER BAR LIFTER	
8	S39661001	1	タネネジ 4	SHOULDER SCREW, M4	
9	S39662001	1	シユオサエウテ ストツハ	MAIN PRESSER ARM STOPPER	
10	060400612	1	ハインド M4X6	SCREW, BIND M4X6	
11	S39663121	1	オサエアケレハネ	PRESSER FOOT LIFTER LEVER	
12	S39664101	1	オサエアケレハネカテー	COLLAR	
13	018062532	1	アナホルト6X25	BOLT, SOCKET M6X25	
14	025060332	1	ヒラサカネタ 16	WASHER, PLAIN L 6	
15	S39665001	1	オサエアケレハネハネ	SPRING	
16	047502542	1	スプリングピンAW5	PIN, SPRING ROLL AW5	
17	S39770001	1	シメネジ 4	SCREW, M4	
18	021400212	1	2シユナツト4	NUT, 2 M4	
19	S20485001	1	オサエアケリンク	PRESSER BAR LIFTER LINK	
20	S39666001	1	オサエアケレハネ	LIFTER LEVER, ;P-BAR	
21	S39667021	1	オサエアケウテクミ	LIFTER ARM ASSY, ;P-BAR	
21-1	047401442	1	スプリングピンAW4	PIN, DOWEL ;AW4	
22	018061632	1	アナホルト6X16	BOLT, SOCKET M6X16	
23	S39669101	1	オサエアケレハネハネ	SPRING	
24	S39670000	1	オサエウテシクメタル	BUSH, ;P-ARM SHAFT	
25	012060632	1	アナヒラ6X6	SET SCREW, SOCKET (FT) M6X6	
26	S39671121	1	オサエウテシク	PRESSER ARM SHAFT	
27	048090342	2	トメワE9	RETAINING RING, E9	
28	S30562000	1	サカネ	WASHER	
29	S39672001	1	オサエウテピン	PIN, ;P-ARM	
30	S46903001	1	アタマツキトメネジ 4X5	SET SCREW, M4X5	
34	S37070121	1	フィンガードV	FINGER GUARD, V	
35	060300412	1	ハインド M3X4	SCREW, BIND M3X4	
40	S20494001	1	フクオサエウテ	SUB PRESSER ARM	
41	062670712	1	ナヘコ357-40X7	SCREW, PAN SM3.57-40X7	
42	S20495001	1	オサエストツハ	PRESSER FOOT STOPPER	
43	060300612	1	ハインド M3X6	SCREW, BIND M3X6	
44	S23364000	1	<テーピング用> テープアンナイ	<For Taping> TAPE GUIDE	

M020
W020

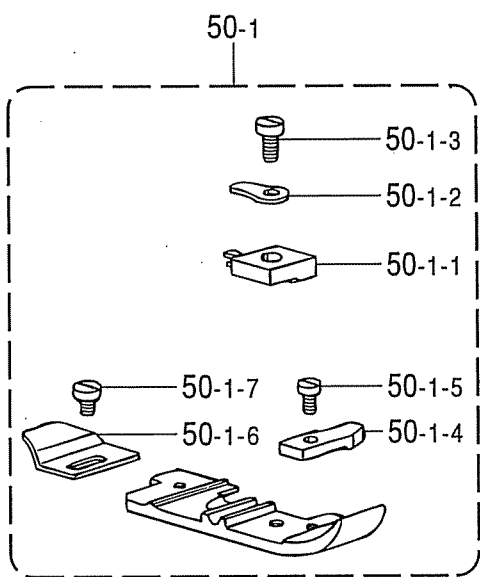

M420
W420

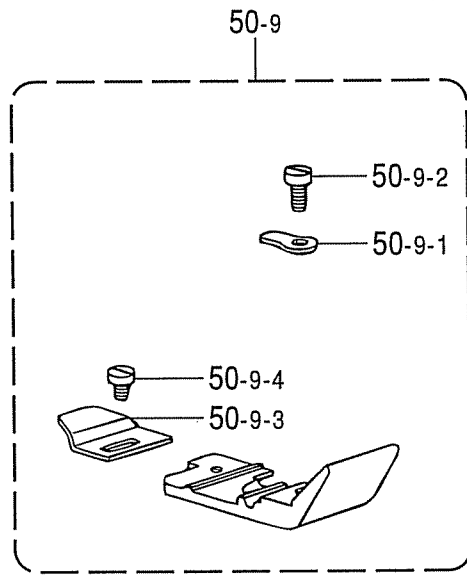

M520
W520

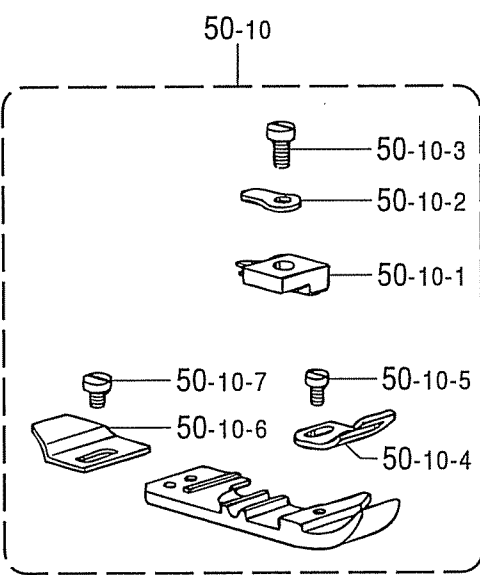

M560
W560

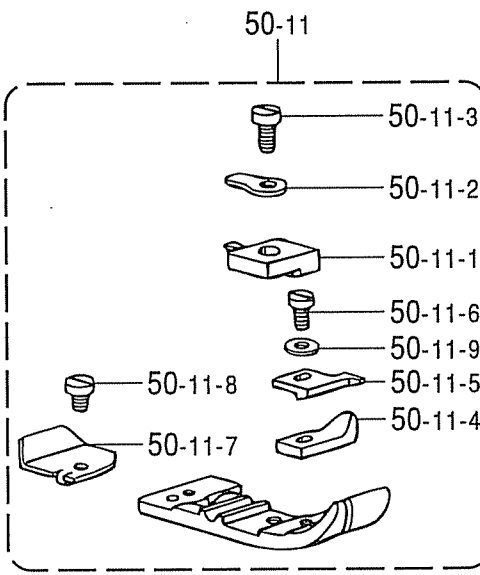

W820

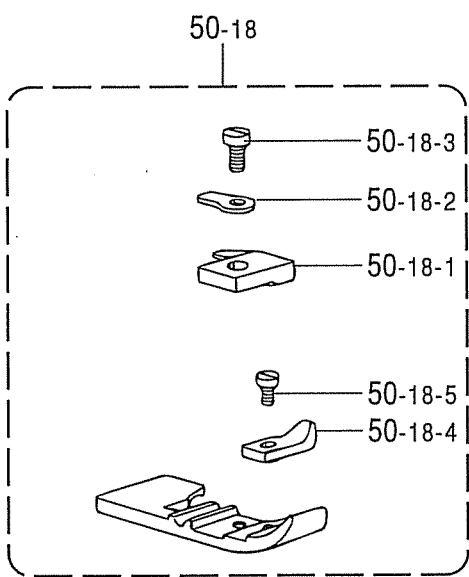

M060
W060
W070
W870

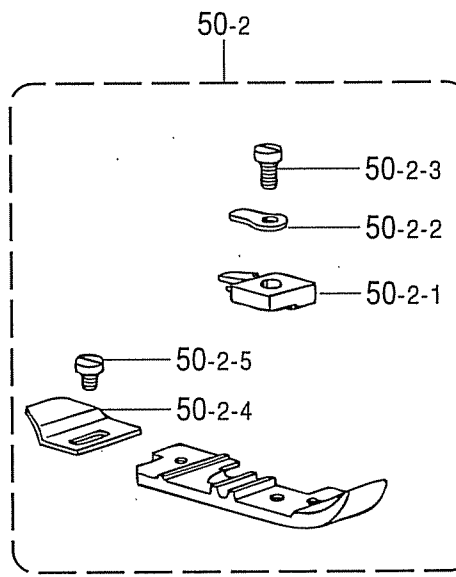

F2. 押工関係 / Presser foot mechanism

REF.NO	CODE	Q'TY	ヒンメイ	NAME OF PARTS	RM
50-1	*	1	<M020,M021,W0S0,W020,W021>	PRESSER FOOT ASSY	
50-1-1	*	1	オサイクミ	STITCH TONGUE	
50-1-2	S19496001	1	ツメ	SETTING PLATE, P-FOOT	
50-1-3	150755001	1	オサトリツケイ	SCREW, SM3.18	
50-1-4	S19258001	1	シメネジ 3.18	PRESSER FOOT, F	
50-1-5	S01295001	1	オサIF	SCREW, SM2.38X3.5	
50-1-6	S19259001	1	シメネジ 2.38X3.5	PRESSER FOOT, B	
50-1-7	140530002	1	オサIB	SCREW, SM2.38	
50-9	*	1	<M420,W420>	PRESSER FOOT ASSY	
50-9-1	S19496001	1	オサイクミ	SETTING PLATE, P-FOOT	
50-9-2	106640001	1	オサトリツケイ	SCREW, SM3.18	
50-9-3	S19259001	1	シメネジ 3.18	PRESSER FOOT, B	
50-9-4	140530002	1	オサIB	SCREW, SM2.38	
50-10	*	1	<M520,W520>	PRESSER FOOT ASSY	
50-10-1	*	1	オサイクミ	STITCH TONGUE	
50-10-2	S19496001	1	ツメ	SETTING PLATE, P-FOOT	
50-10-3	150755001	1	オサトリツケイ	SCREW, SM3.18	
50-10-4	S19296001	1	シメネジ 3.18	TAPE GUIDE	
50-10-5	105288001	1	テープガイド	SCREW, SM2.38	
50-10-6	S19259001	1	シメネジ 2.38	PRESSER FOOT, B	
50-10-7	140530002	1	オサIB	SCREW, SM2.38	
50-11	*	1	<M560,W560>	PRESSER FOOT ASSY	
50-11-1	*	1	オサイクミ	STITCH TONGUE	
50-11-2	S19496001	1	ツメ	SETTING PLATE, P-FOOT	
50-11-3	150755001	1	オサトリツケイ	SCREW, SM3.18	
50-11-4	S19279001	1	シメネジ 3.18	PRESSER FOOT, F	
50-11-5	S19300001	1	オサIF	TAPE GUIDE	
50-11-6	062630612	1	テープガイド	SCREW, PAN SM2.38-56X6	
50-11-7	S19299001	1	ナット 238-56X6	PRESSER FOOT, B	
50-11-8	140530002	1	シメネジ 2.38	SCREW, SM2.38	
50-11-9	026260136	1	ヒラサガネコカ 2.6	WASHER, PLAIN S 2.6	
50-18	*	1	<W82S,W820>	PRESSER FOOT ASSY	
50-18-1	*	1	オサイクミ	STITCH TONGUE	
50-18-2	S19496001	1	ツメ	SETTING PLATE, P-FOOT	
50-18-3	150755001	1	オサトリツケイ	SCREW, SM3.18	
50-18-4	S19279001	1	シメネジ 3.18	PRESSER FOOT, F	
50-18-5	060630412	1	オサIF	SCREW, BIND SM2.38-56X4	
50-2	*	1	<M060,W060,W070,W870>	PRESSER FOOT ASSY	
50-2-1	*	1	オサイクミ	STITCH TONGUE	
50-2-2	S19496001	1	ツメ	SETTING PLATE, P-FOOT	
50-2-3	150755001	1	オサトリツケイ	SCREW, SM3.18	
50-2-4	S19259001	1	シメネジ 3.18	PRESSER FOOT, B	
50-2-5	140530002	1	オサIB	SCREW, SM2.38	

M620
W620

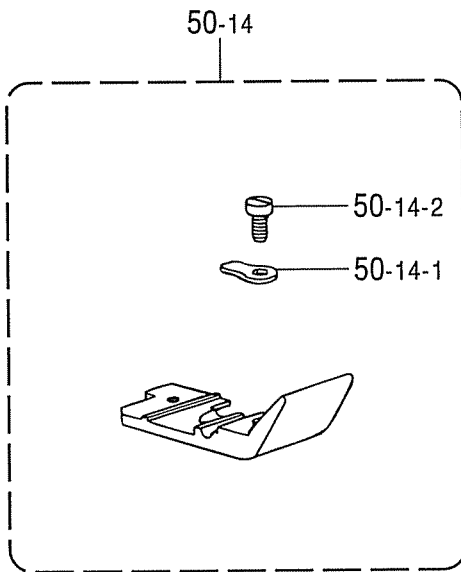

M040
W040

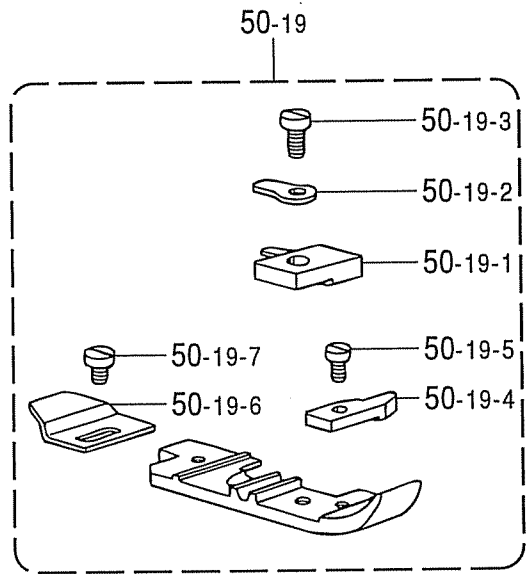

W050

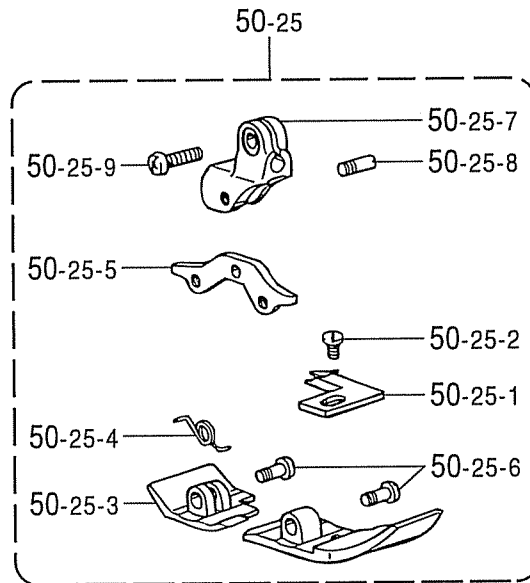

F2. 押工関係 / Presser foot mechanism

REF.NO	CODE	Q'TY	ヒンメイ	NAME OF PARTS	RM
50-14	*	1	<M620,W620> オサイクミ	PRESSER FOOT ASSY	
50-14-1	S19496001	1	オサイトリツケ	SETTING PLATE, P-FOOT	
50-14-2	106640001	1	シメネジ 3.18	SCREW, SM3.18	
50-19	*	1	<M040,W040,W050> オサイクミ	PRESSER FOOT ASSY	
50-19-1	*	1	ツメ	STITCH TONGUE	
50-19-2	S19496001	1	オサイトリツケ	SETTING PLATE, P-FOOT	
50-19-3	150755001	1	シメネジ 3.18	SCREW, SM3.18	
50-19-4	S29870001	1	オサIF	PRESSER FOOT, F	
50-19-5	S01295001	1	シメネジ 2.38X3.5	SCREW, SM2.38X3.5	
50-19-6	S19259001	1	オサIB	PRESSER FOOT, B	
50-19-7	140530002	1	シメネジ 2.38	SCREW, SM2.38	
50-25	*	1	<W050> オサイクミ	PRESSER FOOT ASSY	
50-25-1	*	1	ツメ	STITCH TONGUE	
50-25-2	S01295001	1	シメネジ 2.38X3.5	SCREW, SM2.38X3.5	
50-25-3	S30901001	1	オサIB	PRESSER FOOT, B	
50-25-4	S30902001	1	オサIBネジ リハネ	SPRING TWIST	
50-25-5	S30903001	1	オサIFBサエ	PRESSER FOOT, FB SUPPORT	
50-25-6	S30904001	2	オサIFBサエネジ	SCREW, PRESSER FOOT SUPPORT	
50-25-7	S30905001	1	フクオサエ	SUB PRESSER ARM	
50-25-8	S19311101	1	オサエサエネジ	SCREW	
50-25-9	062670712	1	ナハコ 357-40X7	SCREW, PAN SM3.57-40X7	

G. 送り関係 / Feed mechanism

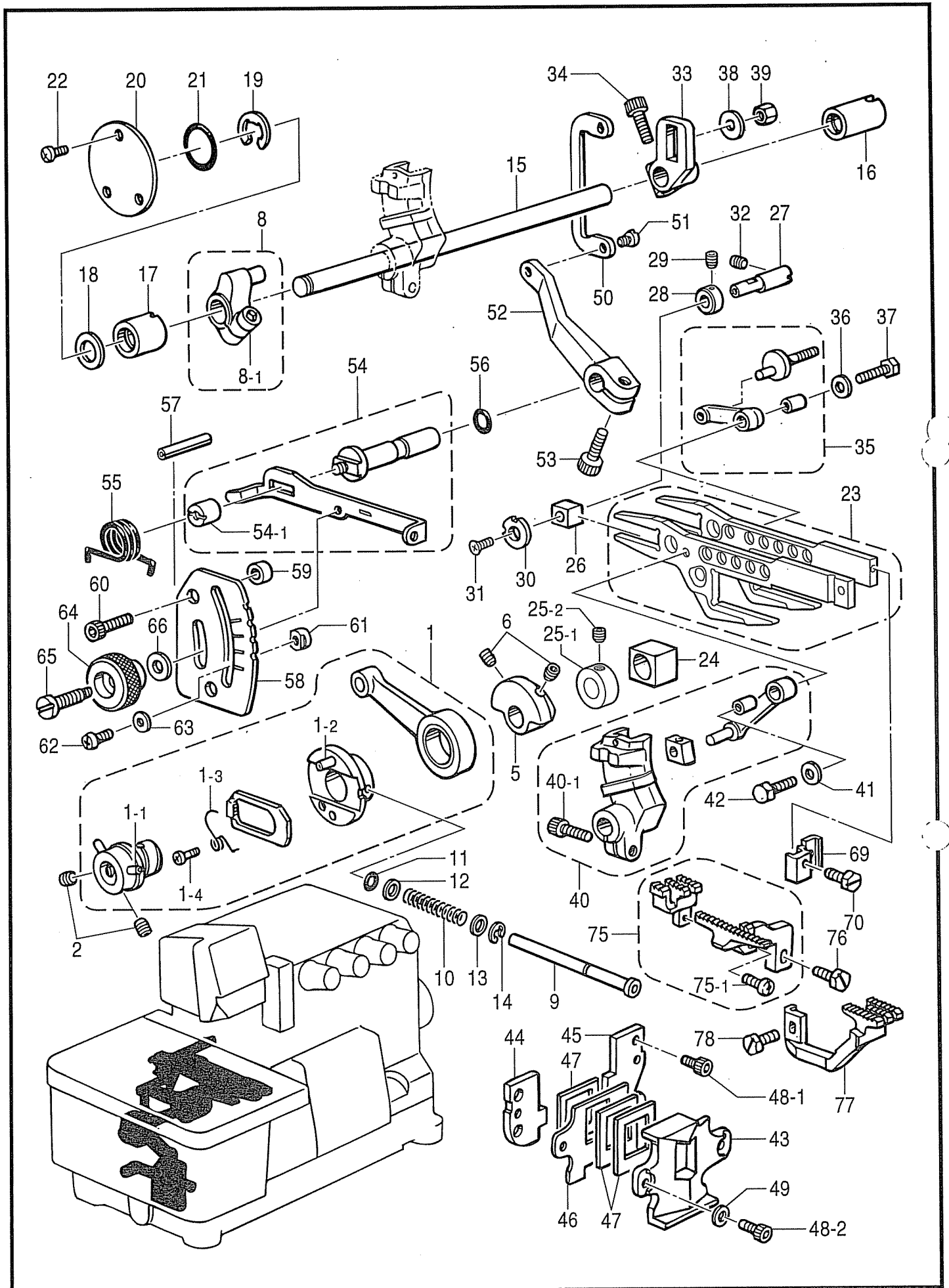

G. 送り関係 / Feed mechanism

REF.NO	CODE	Q'TY	ヒンメイ	NAME OF PARTS	RM
1	S39578001	1	ハンシリンクミ	ECCENTRIC WHEEL ASSY	
1-1-1	047301242	2	スプリングピンAW3	PIN, SPRING ROLL AW3	
1-2-1	047301242	1	スプリングピンAW3	PIN, SPRING ROLL AW3	
1-3	S39585001	1	ラチェットメネジリハネ	SPRING, TWIST	
1-4	S39586001	1	ハネメネジ3	SCREW, M3	
2	012060632	2	アナヒラ6X6	SET SCREW, SOCKET (FT) M6X6	
5	S39673020	1	バランスウエイト	BALANCE WEIGHT	
6	012060632	2	アナヒラ6X6	SET SCREW, SOCKET (FT) M6X6	
8	S39589021	1	オクリウテクミ	FEED ARM ASSY	
8-1	018061632	1	アナホルト6X16	BOLT, SOCKET M6X16	
9	S39674001	1	オクリチヨウセツホタンジク	FEED ADJUSTING SHAFT	
10	S39675001	1	ホタンジクハネ	SPRING, COMPRESSION	
11	081005070	1	OリングP5	O RING, P5	
12	025710232	1	ヒラサガネチユウ4.76	WASHER, PLAIN M 4.76	
13	025710232	1	ヒラサガネチユウ4.76	WASHER, PLAIN M 4.76	
14	048040342	1	トメE4	RETAINING RING, E4	
15	S39676121	1	オクリシク	FEED SHAFT	
16	S39677021	1	メタル11.11-17	BUSH, 11.11-17	
17	S39678021	1	オクリシクメタル	BUSH, L ;FEED SHAFT	
18	S30562000	1	サガネ	WASHER	
19	048090342	1	トメE9	RETAINING RING, E9	
20	S39679001	1	オクリシクメタルフタ	CAP	
21	081020070	1	OリングP20	O RING, P20	
22	060400612	3	ハイントM4X6	SCREW, BIND M4X6	
23	S50091001	1	オクリタイクミ	FEED BRACKET ASSY	
24	S38312050	1	シヨウケオクリカゴマ	SLIDE BLOCK, F-LIFTING	
25-1	S44955001	1	セツカテ	SET SCREW COLLAR	
25-2	012060632	1	アナヒラ6X6	SET SCREW, SOCKET (FT) M6X6	
26	S39683000	1	オクリタイカゴマ	SLIDE BLOCK, F-BAR	
27	S39684021	1	オクリタイカゴマシク	SHAFT, ;SLIDE BLOCK	
28	S39685001	1	セツカテ	SET SCREW COLLAR	
29	012400432	1	アナヒラ4X4	SET SCREW, SOCKET (FT) M4X4	
30	S20530001	1	サガネ	WASHER	
31	004350812	1	サラコ35X8	SCREW, FLAT M3.5X8	
32	012400832	1	アナヒラ4X8	SET SCREW, SOCKET (FT) M4X8	
33	S42042021	1	シヨウケオクリウテ	MAIN FEED ARM	
34	018061632	1	アナホルト6X16	BOLT, SOCKET M6X16	
35	S39773001	1	シヨウケオクリリンクミ	MAIN FEED LINK ASSY	
36	S39690021	1	サガネ	WASHER	
37	S23360001	1	ホルト5X15	BOLT, M5X15	
38	S02573020	1	サガネ	WASHER	
39	S39691001	1	ナツト5	NUT, M5	
40	S39769051	1	サトウオクリウテリンクミ	DIF. FEED ARM LINK ASSY	
40-1	018061632	1	アナホルト6X16	BOLT, SOCKET M6X16	
41	S39690021	1	サガネ	WASHER	
42	S23360001	1	ホルト5X15	BOLT, M5X15	
43	S38311100	1	オクリタイアンナイカバー	COVER, FEED BAR GUIDE	
44	S39686000	1	オクリタイアンナイL	FEED BAR GUIDE, L	
45	S39687000	1	オクリタイアンナイR	FEED BAR GUIDE, R	
46	S39688001	1	ホウジンイタササエ	FRAGMENT PROTECTOR PLATE	
47	S20526000	3	ホウジンイタ	FRAGMENT PROTECTOR PLATE	
48-1	S43916001	4	アナホルト4X8シール	BOLT, SOCKET M4X8 SEAL	
48-2	018400832	2	アナホルト4X8	BOLT, SOCKET M4X8	
49	025040132	2	ヒラサガネチユウ4	WASHER, PLAIN S 4	
50	S39692021	1	サトウチヨウセツリンク	DIF. FEED ADJUSTING LINK	
51	S20543101	1	シメネジ5	SCREW, M5	
52	S20544000	1	サトウリンクレバー	DIFFERENTIAL LINK LEVER	
53	018061432	1	アナホルト6X14	BOLT, SOCKET M6X14	
54	S39593021	1	サトウチヨウセツレバークミ	DIF. FEED ADJUSTING LEVER ASSY	
54-1	S39596021	1	マルナツト6	NUT, ROUND M6	
55	S20547001	1	レバーハネ	SPRING	

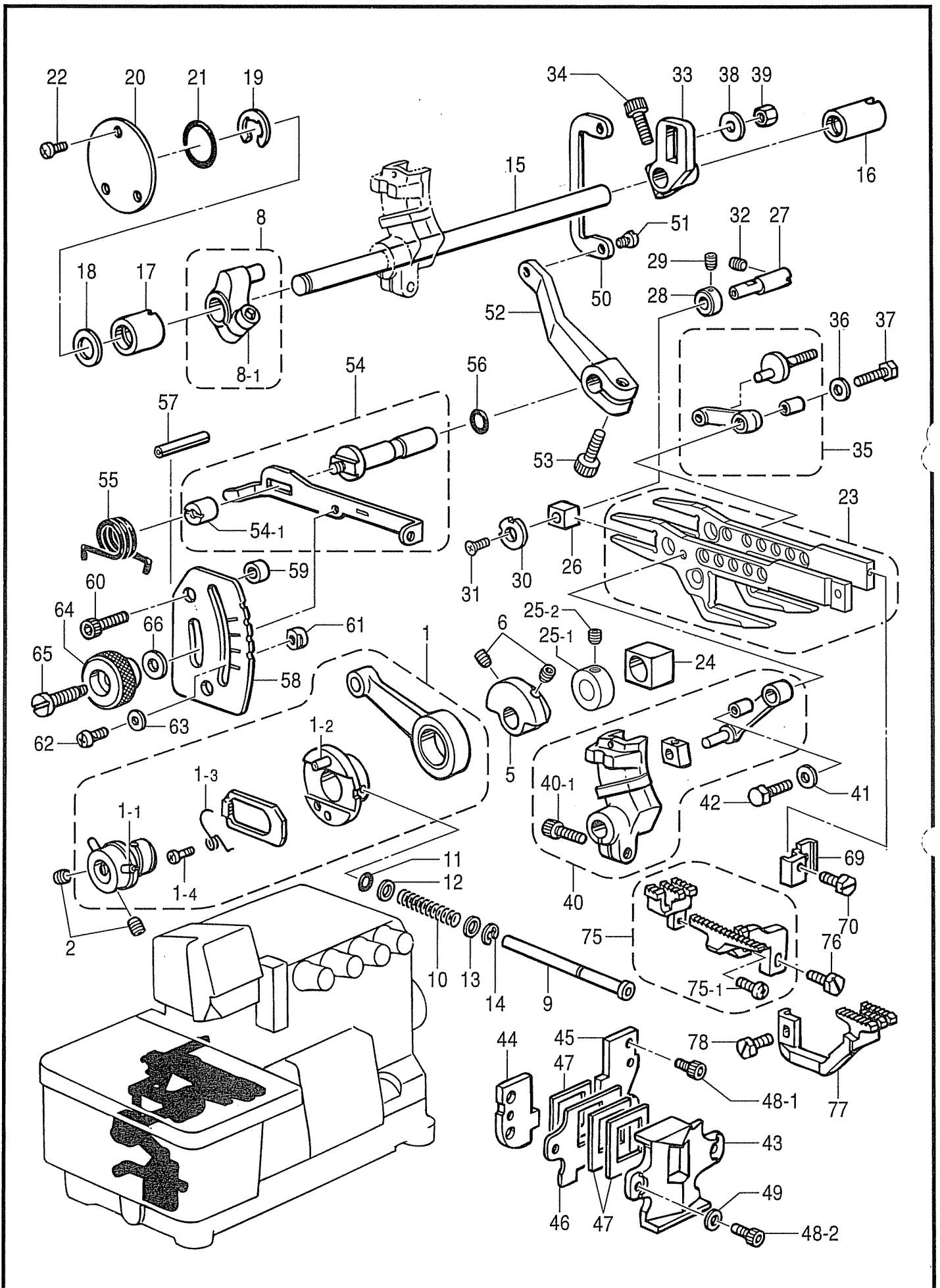

G. 送り関係 / Feed mechanism

REF.NO	CODE	QTY	ヒンメイ	NAME OF PARTS	RM
56	081005670	1	リング PW5	O RING, PW5	
57	047502542	1	スプリングピン AW5	PIN, SPRING ROLL AW5	
58	S39693001	1	サトウヨメモリイタ	DIFFERENTIAL STITCH CONTROL	
59	S20548001	2	カラー	COLLAR	
60	018061632	2	アソルト 6X16	BOLT, SOCKET M6X16	
61	S25818051	2	チヨウセツレハーストツハ	STOPPER, ;ADJUSTING LEVER	
62	060350812	2	ハイント 35X8	SCREW, BIND M3.5X8	
63	025350332	2	ヒラサガネ 13.5	WASHER, PLAIN L 3.5	
64	S39694021	1	セツネシツマミ	KNOB, SCREW	
65	S39695001	1	セツネシ	SET SCREW	
66	S20560001	1	サラハネサガネ	WASHER, FLAT SPRING	
69	S23628101	1	シユオクリハトリツケタイ	FEED DOG SETTING BASE	
70	S23621101	1	ホルト 35X8	BOLT, M3.5X8	
75	*	1	シユオクリハクミ	MAIN FEED DOG ASSY	
75-1	060630712	1	ハイント 238-56X7	SCREW, BIND SM2.38-56X7	
76	S23621101	1	ホルト 35X8	BOLT, M3.5X8	
77	*	1	サトウオクリハ	DIFFERENTIAL FEED DOG	
78	S23621101	1	ホルト 35X8	BOLT, M3.5X8	

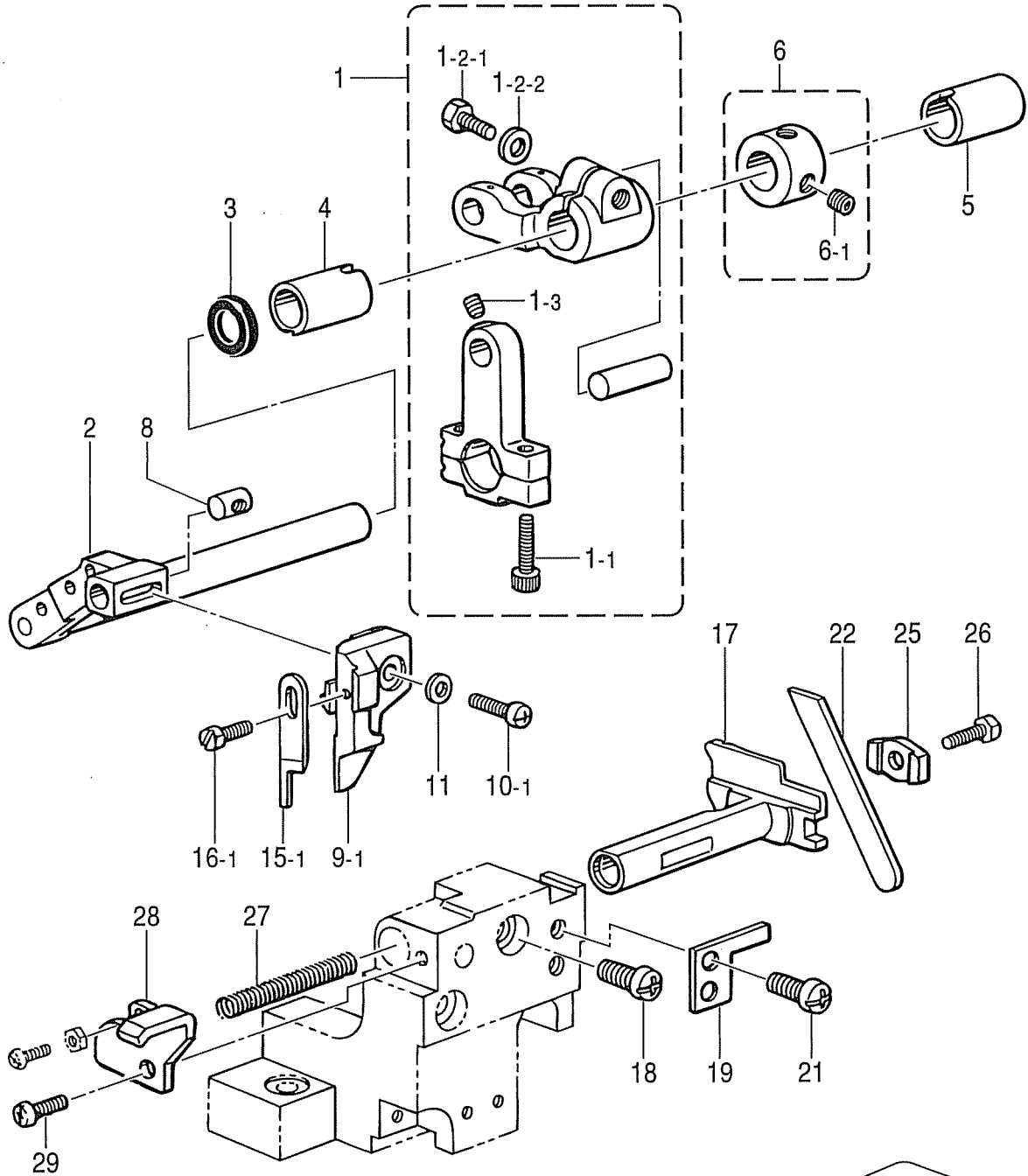

< 角メス用 / For Angle knife >

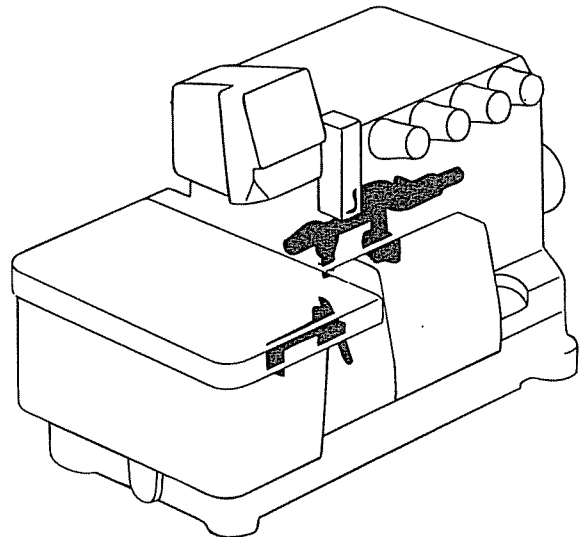
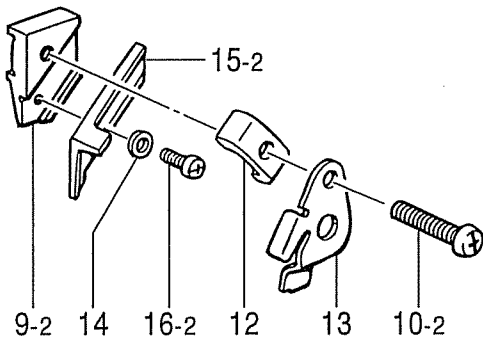

H. 上メス・下メス関係 / Knife mechanism

REF.NO	CODE	QTY	ヒンメイ	NAME OF PARTS	RM
1	S54008001	1	ウワメスクランクロッドクミ	U/KNIFE CRANK ROD ASSY, O	
1-1	018401622	2	アナルト4X16	BOLT, SOCKET M4X16	
1-2-1	017061612	1	ホルト6X16	BOLT, M6X16	
1-2-2	118735002	1	サカネ	WASHER, PLAIN	
1-3	S23342001	1	アトカリ4X5	SET SCREW, SOCKET (CN) M4X5	
2	S20571101	1	ウワメサトウウテ	UPPER KNIFE DIFFERENTIAL ARM	
3	155247000	1	タストシール	DUST SEAL	
4	S39704021	1	ウワメメタル	UPPER KNIFE BUSH, L	
5	S39677021	1	メタル11.11-17	BUSH, 11.11-17	
6	S43527001	1	セットカラークミ	SET SCREW COLLAR ASSY	
6-1	012060632	2	アヒラ6X6	SET SCREW, SOCKET (FT) M6X6	
8	S20574001	1	ウワメスタキナット	NUT	
9-1	S20575001	1	<上メス用> ウワメスタキ	<For Upper Knife> UPPER KNIFE HOLDER	
9-2	S20576001	1	<角メス用> ウワメスタキ	<For Angle Knife> UPPER KNIFE HOLDER	
10-1	062401212	1	<上メス用> ナハコ4X12	<For Upper Knife> SCREW, PAN M4X12	
10-2	062401612	1	<角メス用> ナハコM4X16	<For Angle Knife> SCREW, PAN M4X16	
11	025040132	1	<上メス用> ヒラサガネヨウ4	<For Upper Knife> WASHER, PLAIN S 4	
12	S20577001	1	<角メス用> ウワメスオサ	<For Angle Knife> UPPER KNIFE PRESSER	
13	S20578101	1	ウワメスオサ	UPPER KNIFE PRESSER PLATE	
14	025030132	1	ヒラサガネヨウ3	WASHER, PLAIN S 3	
15-1	144074350	1	<上メス用> ウワメス	<For Upper Knife> UPPER KNIFE	
16-1	S23621101	1	ホルト35X8	BOLT, M3.5X8	
15-2	*	1	<角メス用> カクメス	<For Angle Knife> ANGLE KNIFE, NARROW	
16-2	062300412	1	ナハコ3X4	SCREW, PAN M3X4	
17	S39706001	1	シタメストリツケタ	LOWER KNIFE HOLDER	
18	062060812	1	ナハコ6X8	SCREW, PAN M6X8	
19	S39707001	1	シタメストリツケタ	LOWER KNIFE HOLDER GUIDE	
21	062060812	2	ナハコ6X8	SCREW, PAN M6X8	
22	*	1	シタメス	LOWER KNIFE, T=1.5	
25	S39708001	1	シタメスオサ	LOWER KNIFE PRESSER	
26	017500812	1	ホルト5X8	BOLT, M5X8	
27	S20585001	1	シタメストリツケタ	SPRING, COMPRESSION	
28	S39709021	1	シタメスハネウケ	SPRING HOLDER	
29	060400812	1	ハイントM4X8	SCREW, BIND M4X8	
15-2	S20896101	1	”オプション部品” カクメス	"OPTION PARTS" ANGLE KNIFE, NARROW	
15-2	S20897101	1	カクメス <幅狭>	ANGLE KNIFE, NARROW WAVE EDGE	
15-2	S20579101	1	カクメス <幅狭 波刃>	ANGLE KNIFE, NARROW WAVE EDGE	
15-2	S20898101	1	カクメス <幅広>	ANGLE KNIFE, WIDE	
15-2	S20898101	1	カクメス <幅広 波刃>	ANGLE KNIFE, WIDE WAVE EDGE	

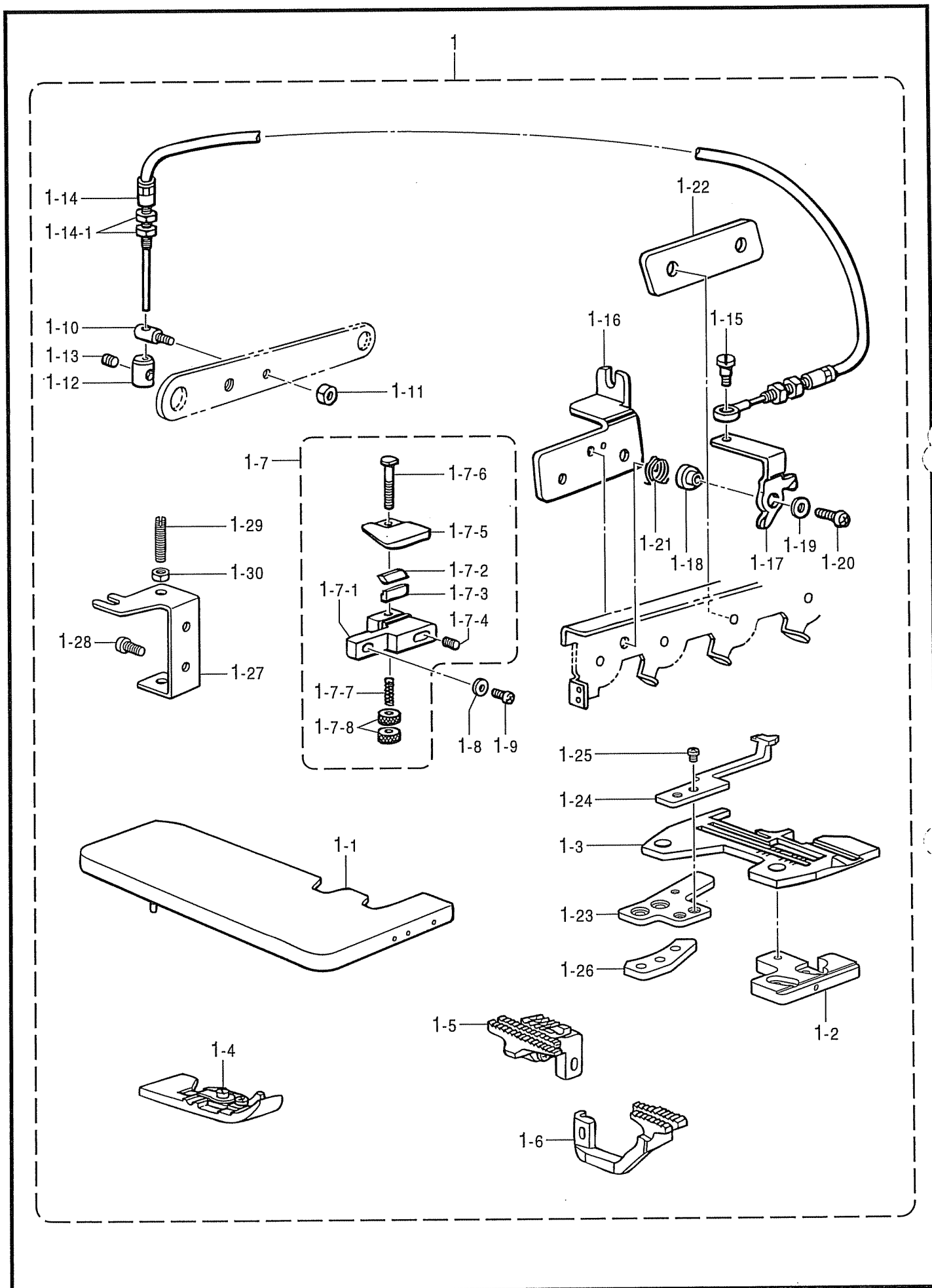

J. バックタック関係 / Back-tacking

REF.NO	CODE	Q'TY	ヒンメイ	NAME OF PARTS	RM
1	S43563001	1	<W820-25> ハックタツクソウチセット	BACK LATCH DEVICE	
1	S43563002	1	<W820-26> ハックタツクソウチセット	BACK LATCH DEVICE	
1-1	S39618001	1	クロスプレート	CLOTH PLATE	
1-2	S39651051	1	ハリタササエイタ	NEEDLE PLATE SUPPORT, F	
1-3	*	1	ハリタ	NEEDLE PLATE	
1-4	*	1	オサエキミ	PRESSER FOOT ASSY	
1-5	S25007001	1	シュクリハクミ	MAIN FEED DOG ASSY	
1-6	S25010001	1	サトウクリハ	DIFFERENTIAL FEED DOG	
1-7	S21335001	1	カエシスイオサエキミ	BACK LATCH PRESSER ASSY	
1-7-1	S21320001	1	カエシスイトダイ	BACK LATCH BLADE HOLDER	
1-7-2	S09234001	1	カエシスイメス	BACK LATCH KNIFE	
1-7-3	S09235001	1	カエシスイメスオサエ	BACK LATCH KNIFE PRESSER	
1-7-4	012400832	2	アヒラ4X8	SET SCREW, SOCKET (FT) M4X8	
1-7-5	S21321001	1	カエシスイオサエイタ	PRESSER PLATE, ;B/LATCH	
1-7-6	S21322001	1	オサエイタオシホウ	PUSH BAR	
1-7-7	116794001	1	オンバネ	SPRING, COMPRESSION	
1-7-8	S21324001	2	オサエイタチヨウセツナツト	ADJUSTING NUT, ;P/PLATE	
1-8	025040132	1	ヒラサカネシヨウ4	WASHER, PLAIN S 4	
1-9	060401012	1	ハイントM4X10	SCREW, BIND M4X10	
1-10	S21315001	1	スタツM4	STUD, M4	
1-11	021400212	1	2シユナツト4	NUT, 2 M4	
1-12	S21316001	1	ワイヤーストツハ-	WIRE STOPPER	
1-13	012400432	1	アヒラ4X4	SET SCREW, SOCKET (FT) M4X4	
1-14	S21314001	1	フレキシブルワイヤークミ	FLEXIBLE WIRE ASSY	
1-14-1	021500303	4	ナツト3シユ5	NUT, 3 M5	
1-15	S23774001	1	タンネジ3.5	SHOULDER SCREW, M3.5	
1-16	S39797001	1	イトユルメトダイ	TENSION RELEASE BASE	
1-17	S39798001	1	イトユルメイタ	TENSION RELEASE PLATE	
1-18	S39799001	1	カラー	COLLAR	
1-19	025040232	1	ヒラサカネチヨウ4	WASHER, PLAIN M 4	
1-20	062401212	1	ナハコ4X12	SCREW, PAN M4X12	
1-21	S39800001	1	イトユルメトシハネ	SPRING	
1-22	S39796001	1	スペーサ	SPACER	
1-23	S39768001	1	ハリタササエイタB	NEEDLE PLATE SUPPORT, B	
1-24	S21326001	1	イトサハキ	LOWER THREAD FINGER	
1-25	062300512	1	ナハコ3X5	SCREW, PAN M3X5	
1-26	S39767021	1	ハリタササエイタBササエ	PLATE, B SUPPORT	
1-27	S23349001	1	レバチヨウセツイタ	LEVER ADJUSTING PLATE	
1-28	060400812	2	ハイントM4X8	SCREW, BIND M4X8	
1-29	011502012	2	トメネジ5X20ヒラ	SET SCREW, (FT)M5X20	
1-30	021500312	2	3シユナツト5	NUT, 3 M5	

K. 上ルーパ関係 / Over looper mechanism

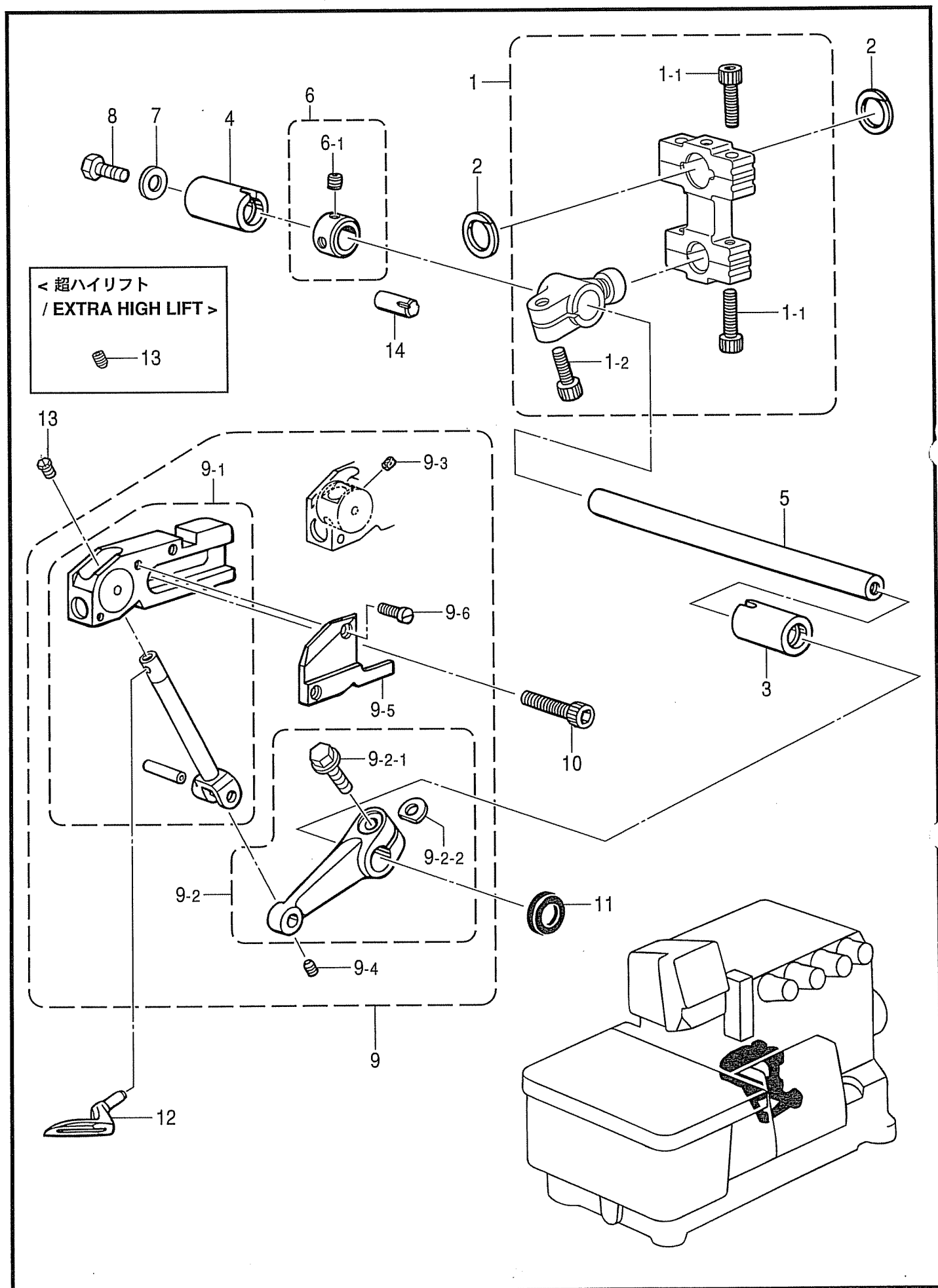

878-N21-307

K. 上ルーパー関係 / Over looper mechanism

REF.NO	CODE	Q'TY	ヒンメイ	NAME OF PARTS	RM
1	S54015001	1	ウフル-ハ°ロツクミHE	OVER LOOPER CON. ROD ASSY, HE	
1-1	018401622	4	アナホルト4X16	BOLT, SOCKET M4X16	
1-2	S23346101	1	アナホルト6X14ホソメ	BOLT, SOCKET M6X14	
2	S20598000	2	ロツフレトメ	ROD STOPPER	
3	S39728021	1	メタル11.11-18	BUSH, 11.11-18	
4	S39677021	1	メタル11.11-17	BUSH, 11.11-17	
5	S20601001	1	ウフル-ハ°シク	OVER LOOPER SHAFT	
6	S43527001	1	セツカテクミ	SET SCREW COLLAR ASSY	
6-1	012060632	2	アナヒラ6X6	SET SCREW, SOCKET (FT) M6X6	
7	S23626001	1	サカネ	WASHER	
8	017060812	1	ホルト6X8	BOLT, M6X8	
<hr/>					
9	S52053001	1	<ハイリフト用> ウフル-ハ°キコウクミSH	<For High lift> OVER LOOPER SET, SH	
9-1	S52054001	1	ウフル-ハ°キコウクミ	OVER LOOPER ASSY	
9-2	S52060001	1	ウフル-ハ°ウテSHクミ	OVER LOOPER ARM ASSY, SH	
13	S46903001	1	アナツキトメネジ 4X5	SET SCREW, M4X5	
<hr/>					
9	S52062001	1	<超ハイリフト用> ウフル-ハ°キコウクミE	<For Extra high lift> OVER LOOPER SET, E	
9-1	S52054001	1	ウフル-ハ°キコウクミ	OVER LOOPER ASSY	
9-2	S52063001	1	ウフル-ハ°ウテEクミ	OVER LOOPER ARM ASSY, E	
13	012400432	1	アナヒラ4X4	SET SCREW, SOCKET (FT) M4X4	
<hr/>					
9-2-1	S46899001	1	サカネツキホルト6X16	BOLT, (W/WASHER) M6X16	
9-2-2	155162001	1	スペーサ	SPACER	
9-3	S29700000	2	ウフル-ハ°アンナイフェルト	FELT	
9-4	S23342001	1	アナトカリ4X5	SET SCREW, SOCKET (CN) M4X5	
9-5	S52059001	1	ウフル-ハ°アンナイサエ	OVER LOOPER GUIDE SUPPORT	
9-6	S20355002	2	シメネジ 3X8.5	SCREW, M3X8.5	
10	018061432	2	アナホルト6X14	BOLT, SOCKET M6X14	
11	155247000	1	ダストシール	DUST SEAL	
12	*	1	ウフル-ハ°	OVER LOOPER, B	
14	118550001	1	ミノツキピン	PIN, DOWEL	

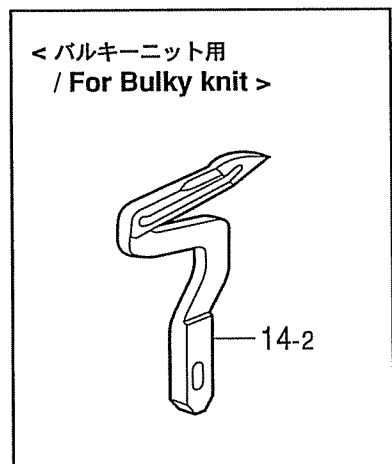
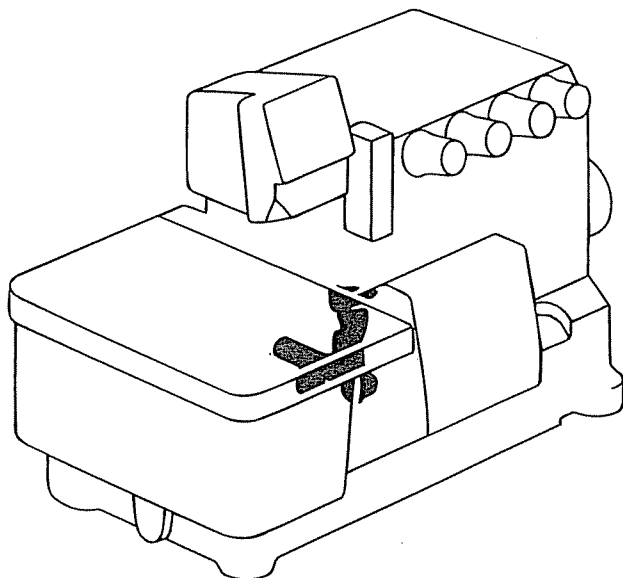
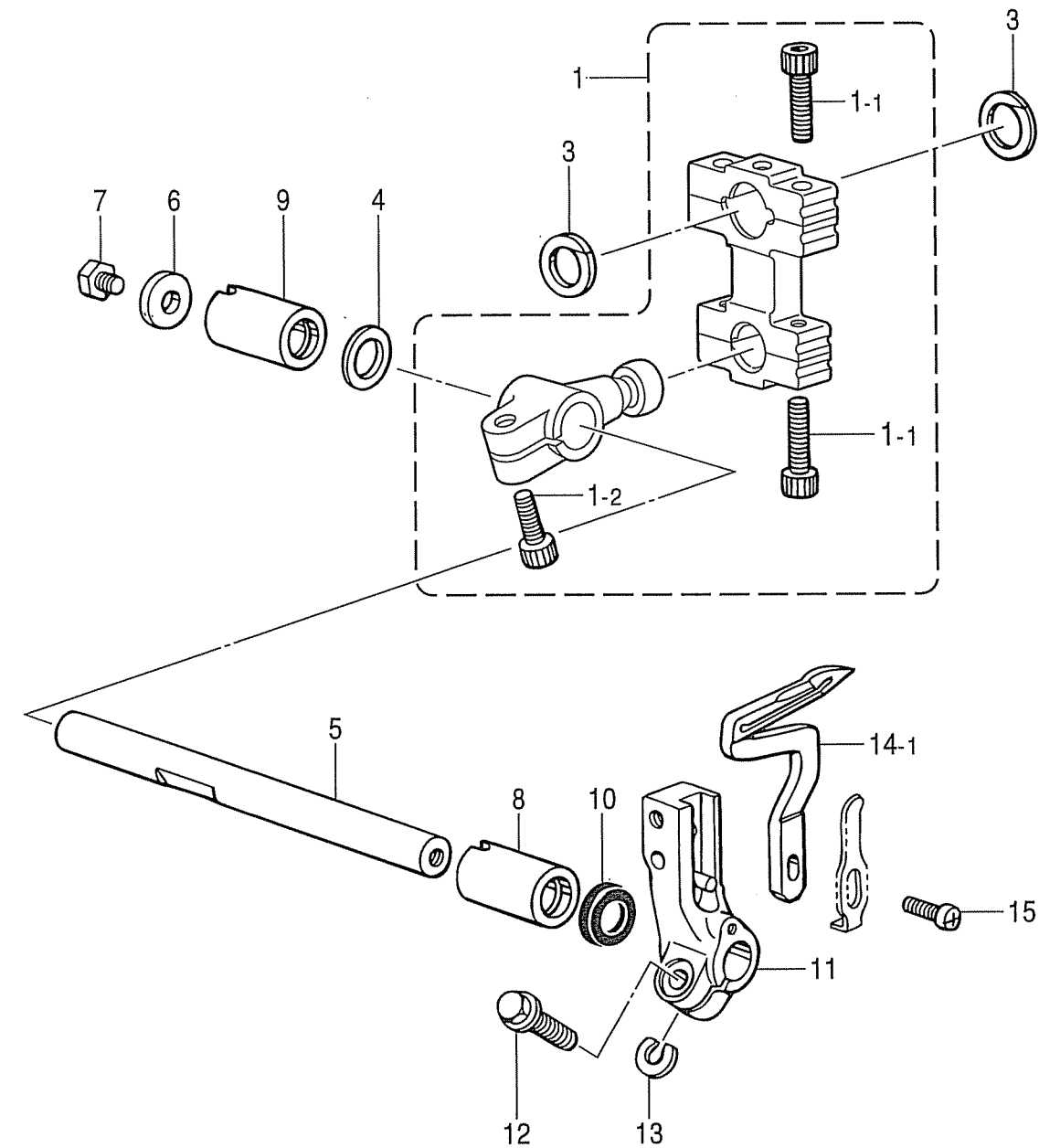

L. 下ルーパー関係 / Under looper mechanism

REF.NO	CODE	QTY	ヒンメイ	NAME OF PARTS	RM
1	S54016001	1	<ハイリフト用> シタル-ハ°ロツト°クミ0SH	<For High lift> U/LOOPER CON. ROD ASSY, OSH	
1-1	018401622	4	アナルト4X16	BOLT, SOCKET M4X16	
1-2	S23346101	1	アナルト6X14ホソメ	BOLT, SOCKET M6X14	
1	S54017001	1	<超ハイリフト用> シタル-ハ°ロツト°クミ0E	<For Extra high lift> U/LOOPER CON. ROD ASSY, OE	
1-1	018401622	4	アナルト4X16	BOLT, SOCKET M4X16	
1-2	S23346101	1	アナルト6X14ホソメ	BOLT, SOCKET M6X14	
3	S20598000	2	ロツト°フレツト°メ	ROD STOPPER	
4	S20621001	1	カラ-	COLLAR	
5	S46904001	1	シタル-ハ°シク	UNDER LOOPER SHAFT	
6	S23626001	1	サ°ガ°ネ	WASHER	
7	017060812	1	ホ°ルト6X8	BOLT, M6X8	
8	S39728021	1	メタル11.11-18	BUSH, 11.11-18	
9	S39677021	1	メタル11.11-17	BUSH, 11.11-17	
10	155247000	1	タ°ストシール	DUST SEAL	
11	S20625151	1	シタル-ハ°トリツケタ°イ	UNDER LOOPER HOLDER	
12	S23614101	1	アランジ°ホ°ルト5X14	BOLT, M5X14	
13	148782001	1	ス°-サ	SPACER	
14-1	S20627001	1	シタル-ハ°	UNDER LOOPER	
14-2	S40866001	1	<ハ°ルキ°ニット用> シタル-ハ°	<For Bulky knit> UNDER LOOPER	
15	060351012	1	ハ°イント°3.5X10	SCREW, BIND M3.5X10	

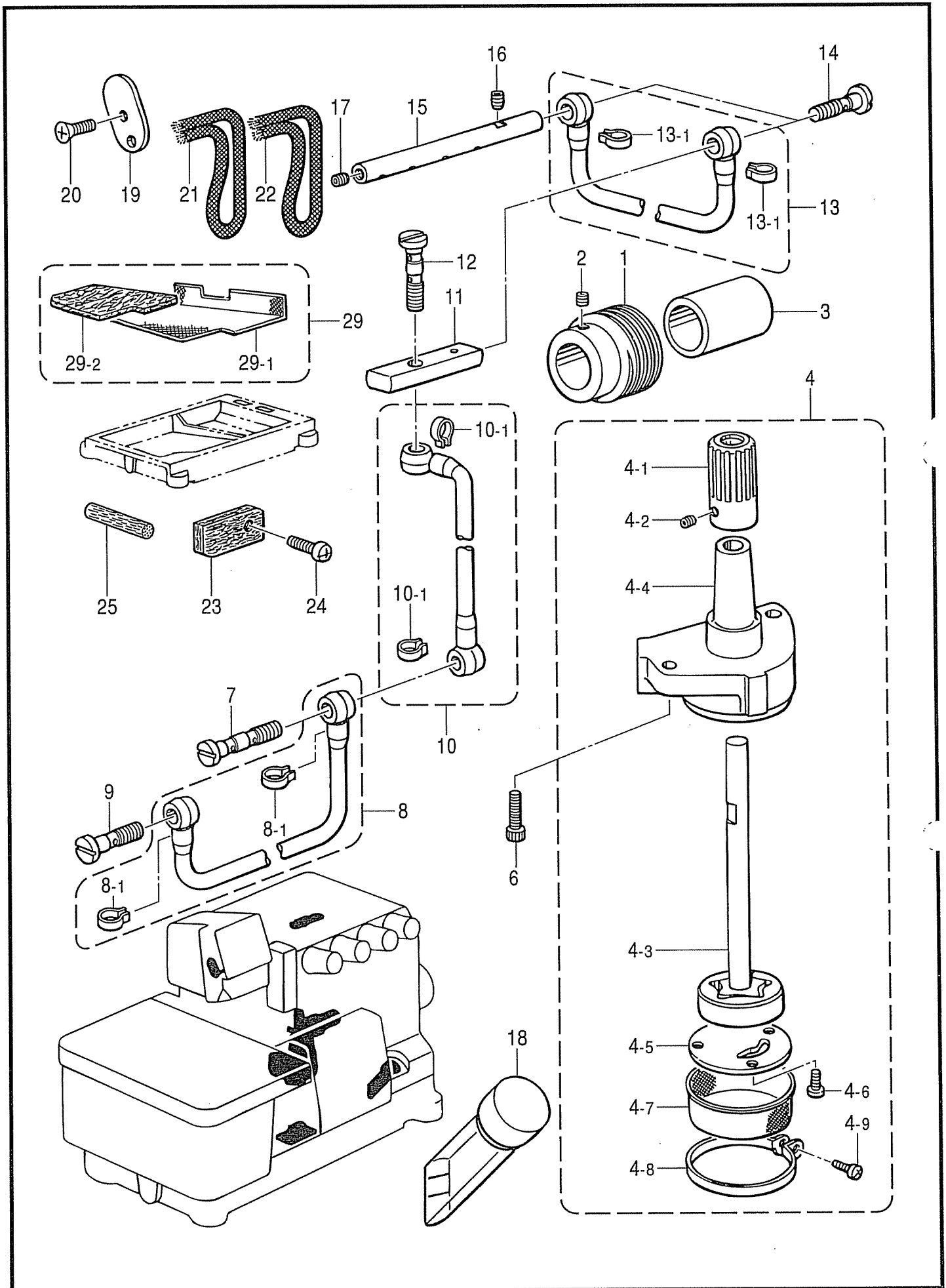

M. 給油潤滑関係 / Lubrication

REF.NO	CODE	Q'TY	品名	NAME OF PARTS	RM
1	S20655101	1	ウーム	WORM	
2	012500532	2	アナヒラ5X5	SET SCREW, SOCKET (FT) M5X5	
3	S39743001	1	カラ	COLLAR	
4	S39597001	1	トロコイト・ポンプ・クミ	PUMP ASSY	
4-1	S20657001	1	ウームホイール	WORM WHEEL	
4-2	012400432	2	アナヒラ4X4	SET SCREW, SOCKET (FT) M4X4	
4-3	S39599001	1	ポンプ・ローター・クミ	PUMP INNER ROTER ASSY	
4-4	S39598000	1	ポンプ・ケース	PUMP CASE	
4-5	S39601000	1	ポンプ・タイフタ	PUMP BODY COVER	
4-6	062400812	3	ナヘコ4X8	SCREW, PAN M4X8	
4-7	S39602000	1	ロカモウ	OIL FILTER	
4-8	S39603001	1	ロカモウオサI	OIL FILTER FLANGE	
4-9	062401212	1	ナヘコ4X12	SCREW, PAN M4X12	
6	018061432	2	アナホルト6X14	BOLT, SOCKET M6X14	
7	S39744021	1	ハイユハ°イフ°ツキ°テ	OIL PIPE JOINT	
8	S39745001	1	ヒ°ニルチユ°フ°クミ	OIL TUBE ASSY	
8-1	147942001	2	ヒ°ニルチユ°フ°トメカ°ネ	STOP RING	
9	S20199001	1	ハイユハ°イフ°ツキ°テ	OIL PIPE JOINT	
10	S39747001	1	ヒ°ニルチユ°フ°クミ	OIL TUBE ASSY	
10-1	147942001	2	ヒ°ニルチユ°フ°トメカ°ネ	STOP RING	
11	S39751021	1	キユウユハ°イフ°	OIL PIPE	
12	S39744021	1	ハイユハ°イフ°ツキ°テ	OIL PIPE JOINT	
13	S39749001	1	ヒ°ニルチユ°フ°クミ	OIL PIPE ASSY	
13-1	147942001	2	ヒ°ニルチユ°フ°トメカ°ネ	STOP RING	
14	S20199001	2	ハイユハ°イフ°ツキ°テ	OIL PIPE JOINT	
15	S39752021	1	ロツト°キユウユハ°イフ°	OIL PIPE	
16	012400432	1	アナヒラ4X4	SET SCREW, SOCKET (FT) M4X4	
17	012060632	1	アナヒラ6X6	SET SCREW, SOCKET (FT) M6X6	
18	148084001	1	オイルゲ°シ°マド°	OIL GAUGE WINDOW	
19	S20668200	1	ハリホ°ウリンク°フェルト	FELT, ;N-BAR LINK	
20	061400812	1	サラコM4X8	SCREW, FLAT M4X8	
21	S49337000	1	クミヒモ70	WICK, L=70	
22	S20671000	1	クミヒモ100	WICK, L=100	
23	S20669000	1	フェルト	FELT	
24	060400812	1	ハ°イント°M4X8	SCREW, BIND M4X8	
25	S20392000	1	フェルト	FELT	
29	S43523000	1	フィルタ°クミ	FILTER ASSY	
29-1	S43521000	1	ロカモウD	FILTER, D	
29-2	S43522000	1	オイルフィルタ°	OIL FILTER	

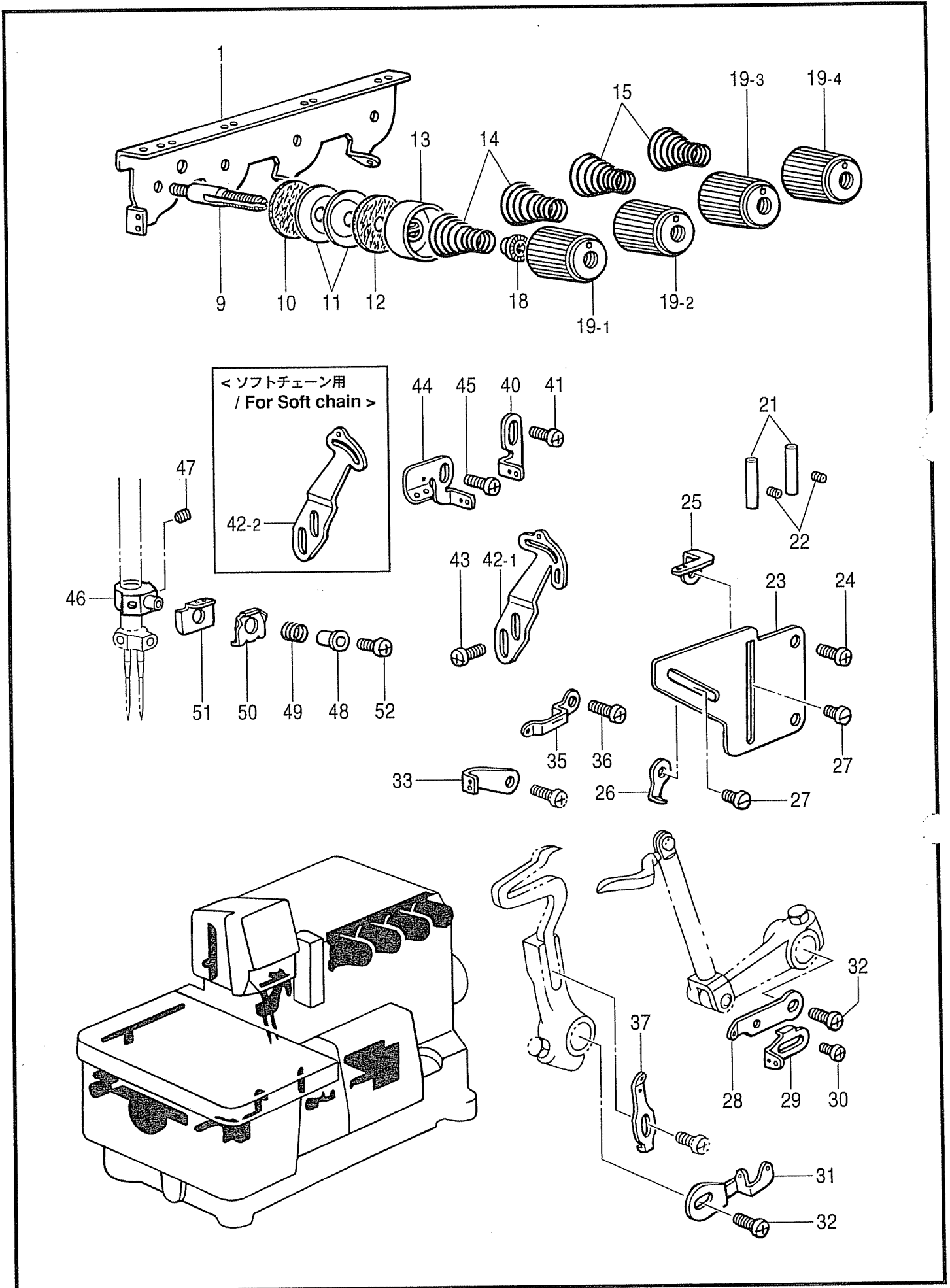

N. 糸調子関係 / Thread tension

REF.NO	CODE	QTY	ヒンメイ	NAME OF PARTS	RM
1	S38328051	1	シユイトアンナイ	MAIN THREAD GUIDE	
9	S20676051	4	トチヨウシホウ	TENSION STUD	
10	S20677000	4	トチヨウシサヲエルト	FELT, T-DISC	
11	S20673001	8	トチヨウシサヲ	TENSION DISC	
12	110832009	4	トチヨウシサヲエルト	FELT, ;T-DISC	
13	144103009	4	トチヨウシサヲサヒ	DISC PRESSER, ;TENSION	
14	S20678001	2	トチヨウシハネ	TENSION SPRING, L	
15	S20679001	2	トチヨウシハネ	TENSION SPRING, M	
18	S20681000	4	チヨウシハネウエサカネ	WASHER	
19-1	S20682103	1	トチヨウシナツト <赤>	TENSION NUT, RED	
19-2	S20682101	1	トチヨウシナツト <水色>	TENSION NUT, LIGHT BLUE	
19-3	S20682104	1	トチヨウシナツト <黄>	TENSION NUT, YELLOW	
19-4	S20682102	1	トチヨウシナツト <緑>	TENSION NUT, GREEN	
21	146592001	2	トアンナイハパイ	THREAD GUIDE PIPE	
22	S23452002	2	アナヒラ4X3.2	SET SCREW, SOCKET (FT) M4X3.2	
23	S20684101	1	トアンナイトダイ	THREAD GUIDE BRACKET	
24	060400612	2	ハイントM4X6	SCREW, BIND M4X6	
25	S20685001	1	シタルハイトアンナイR	UNDER LOOPER THREAD GUIDE, R	
26	S20686001	1	ウアルハイトアンナイR	OVER LOOPER THREAD GUIDE, R	
27	S23418002	2	シメネジ 4X5	SCREW, M4X5	
28	S21133001	1	ウアルハテンヒンR	OVER LOOPER THREAD TAKE-UP, R	
29	S21134001	1	シタルハテンヒンR	UNDER LOOPER THREAD TAKE-UP, R	
30	060300412	1	ハイントM3X4	SCREW, BIND M3X4	
31	S21135001	1	ルハテンヒンL	LOOPER THREAD TAKE-UP, L	
32	060400612	2	ハイントM4X6	SCREW, BIND M4X6	
33	S21137001	1	ルハイトアンナイM1	LOOPER THREAD GUIDE, M1	
35	S21136101	1	ウアルハイトアンナイL	OVER LOOPER THREAD GUIDE, L	
36	060400612	1	ハイントM4X6	SCREW, BIND M4X6	
37	S20687001	1	シタルハイトアンナイL	UNDER LOOPER THREAD GUIDE, L	
40	S21129001	1	ハリトアンナイB	NEEDLE THREAD GUIDE, B	
41	060400612	1	ハイントM4X6	SCREW, BIND M4X6	
42-1	S21130051	1	ハリトテンヒンA <ソフトチェーン用>	NEEDLE THREAD TAKE-UP, A <For Soft chain>	
42-2	S21132001	1	ハリトテンヒンC	NEEDLE THREAD TAKE-UP, C	
43	060400612	2	ハイントM4X6	SCREW, BIND M4X6	
44	S21128001	1	ハリトアンナイA	NEEDLE THREAD GUIDE, A	
45	060400612	1	ハイントM4X6	SCREW, BIND M4X6	
46	S38330050	1	ハリトオサエホルダー	NEEDLE THREAD PRESSER HOLDER	
47	146427001	2	アタメネジ 3.18φホミ	SET SCREW, SOCKET (CP) SM3.18	
48	S20689001	1	ハリトオサエカラー	NEEDLE THREAD PRESSER COLLAR	
49	S20690001	1	ハリトオサエハネ	SPRING, COMPRESSION	
50	S20691001	1	ハリトオサエイタ	NEEDLE THREAD PRESSER PLATE	
51	S20692001	1	ハリトアンナイ	NEEDLE THREAD GUIDE	
52	060300612	1	ハイントM3X6	SCREW, BIND M3X6	

P1. ラフラー装置関係 / Ruffling attachment

M420
M620
W420
W620

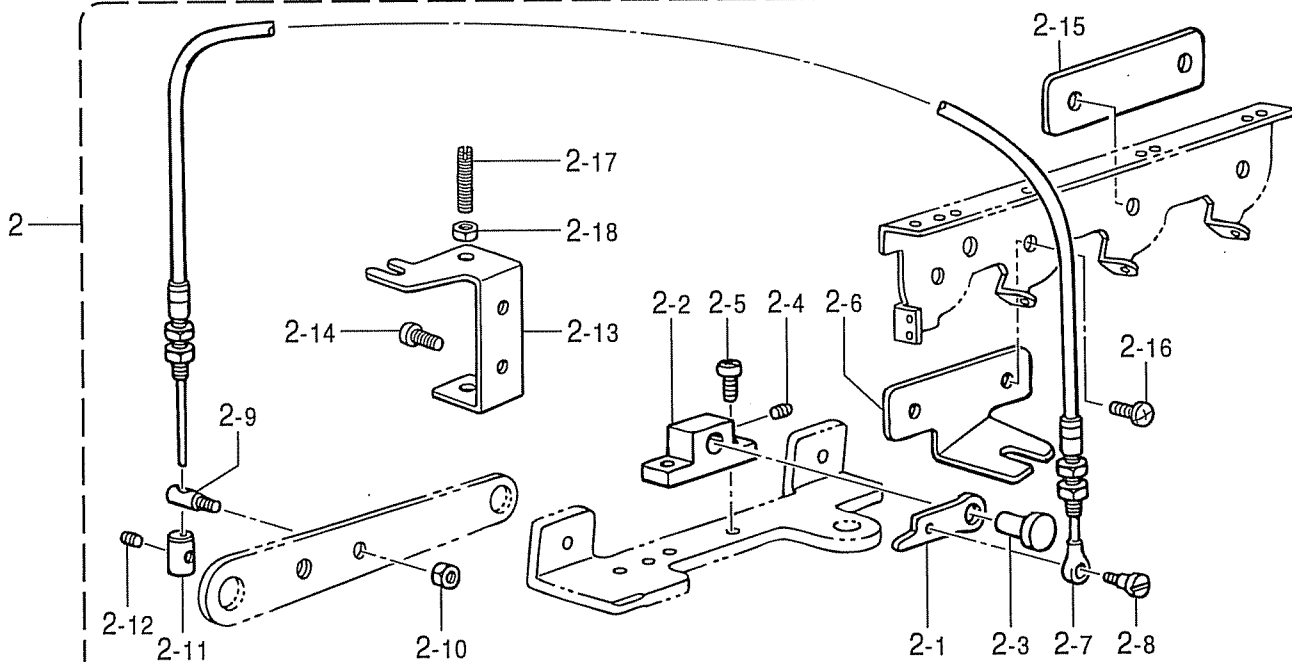
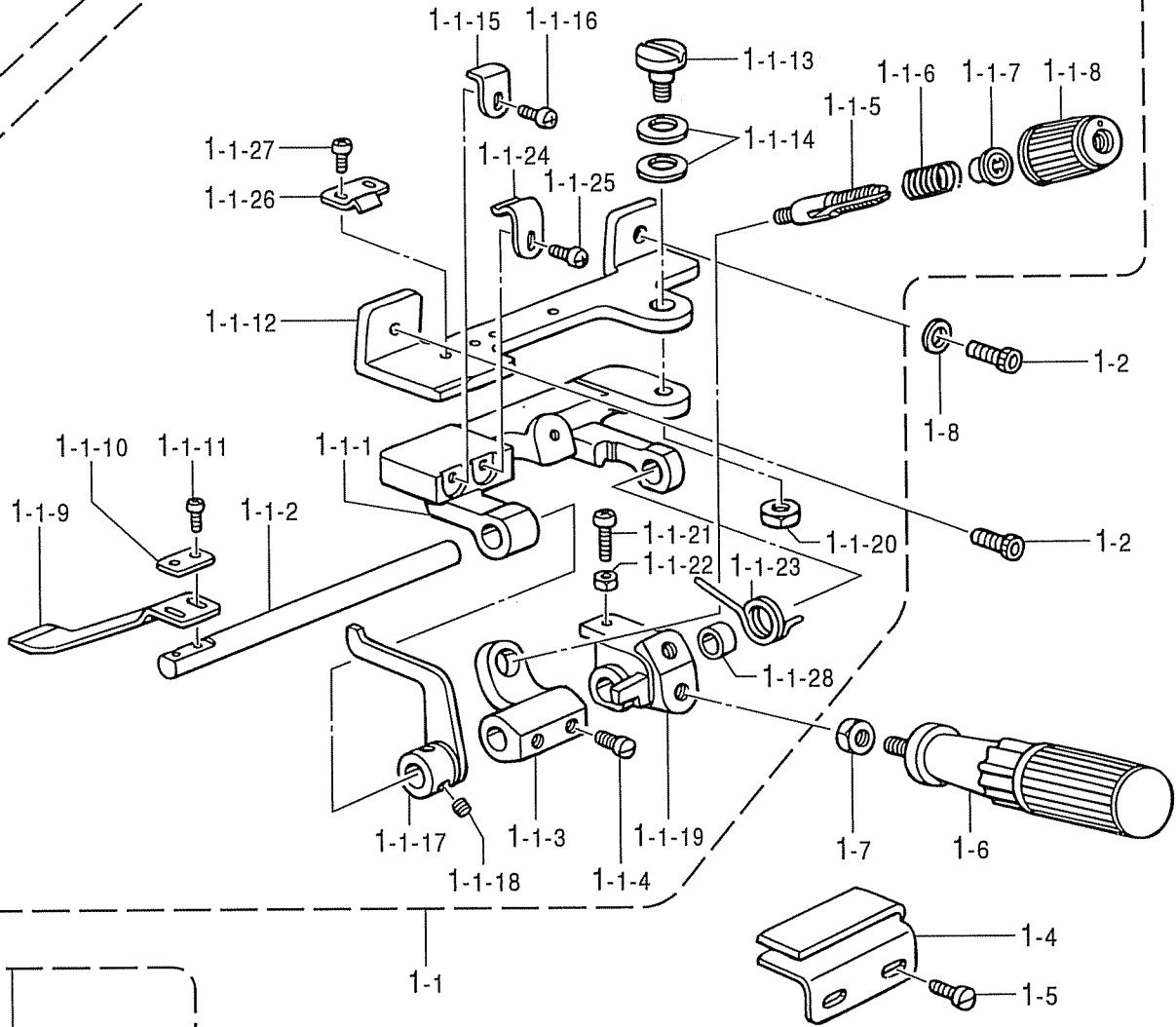

P1. ラフラー装置関係 / Ruffling attachment

REF.NO	CODE	QTY	ヒンメイ	NAME OF PARTS	RM
1	S30134001	1	ラフラーウキ	RUFFLER ASSY	
1-1	S25006001	1	ラフラーソウチウキ	RUFFLER DEVICE SET	
1-1-1	S21294001	1	キジ オサエタイ	RUFFLING BLADE BRACKET	
1-1-2	S21295001	1	キジ オサエトリツケシク	RUFFLING BLADE BASE SHAFT	
1-1-3	S21305001	1	ハネウケ	SPRING BASE	
1-1-4	S23777101	2	アタマツキトメネジ 6	SET SCREW, M6	
1-1-5	S20676051	1	イトチヨウシホウ	TENSION STUD	
1-1-6	S23775001	1	コイルハネ	SPRING, COIL	
1-1-7	S20681000	1	チヨウシハネウエサガネ	WASHER	
1-1-8	S20682105	1	イトチヨウシナツト	TENSION NUT	
1-1-9	S25005001	1	キジ オサエ	RUFFLING BLADE	
1-1-10	144784001	1	キジ オサエサガネ	WASHER	
1-1-11	062300812	2	ナハ コ3X8	SCREW, PAN M3X8	
1-1-12	S21297001	1	ラフラーソウチトリツケタイ	RUFFLER BASE	
1-1-13	S21306001	1	ダンネシ 6	SHOULDER SCREW, M6	
1-1-14	S21307001	2	ハネサガネ	WASHER, SPRING	
1-1-15	S21298001	1	キジ オサエアンナイ	RUFFLING BLADE GUIDE	
1-1-16	062400812	1	ナハ コ4X8	SCREW, PAN M4X8	
1-1-17	S21299001	1	キジ オサエアケ	CLOTH PRESSER BAR LIFTER	
1-1-18	S23651002	2	アナヒラ6X6ホソメ	SET SCREW, SOCKET (FT) M6X5	
1-1-19	S21300001	1	ハント ルトリツケイタ	HANDLE SETTING PLATE	
1-1-20	021060302	1	ナツト3シユ6	NUT, 3 M6	
1-1-21	062401612	1	ナハ コM4X16	SCREW, PAN M4X16	
1-1-22	021400212	1	2シユナツト4	NUT, 2 M4	
1-1-23	S21301001	1	ハント ルモトシハネ	SPRING, TWIST	
1-1-24	S21302001	1	キジ オサエタイトメハネ	SPRING, PLATE (U)	
1-1-25	062400612	1	ナハ コM4X6	SCREW, PAN M4X6	
1-1-26	S21303001	1	キジ オサエタイトメハネ	SPRING, PLATE (D)	
1-1-27	062350512	2	ナハ コ3.5X5	SCREW, PAN M3.5X5	
1-1-28	S21304001	1	カラ	COLLAR	
1-2	018401222	2	アナホ ルト4X12	BOLT, SOCKET M4X12	
1-4	S21590000	1	キジ アンナイ	RUFFLER GUIDE	
1-5	S23418002	2	シメネシ 4X5	SCREW, M4X5	
1-6	S23779001	1	ハント ル	HANDLE	
1-7	021060302	1	ナツト3シユ6	NUT, 3 M6	
1-8	102707002	1	サガネ	WASHER, PLAIN 4	
2	S43530001	1	ラフラーオサエレントウキ	RUFFLER INTERLOCKING PARTS SET	
2-1	S21310001	1	キジ オサエアケレハ	CLOTH PRESSER BAR LIFTER LEVER	
2-2	S21311001	1	オサエアケタイ	PRESSER BAR LIFTER BRACKET	
2-3	S21312001	1	ピン 6.35	PIN, 6.35	
2-4	012060632	1	アナヒラ6X6	SET SCREW, SOCKET (FT) M6X6	
2-5	062350812	2	ナハ コ3.5X8	SCREW, PAN M3.5X8	
2-6	S39795001	1	ワイヤトリツケイタ	WIRE SETTING PLATE	
2-7	S21314001	1	フレキシブルワイヤウキ	FLEXIBLE WIRE ASSY	
2-8	S23774001	1	ダンネシ 3.5	SHOULDER SCREW, M3.5	
2-9	S21315001	1	スタツト M4	STUD, M4	
2-10	021400212	1	2シユナツト4	NUT, 2 M4	
2-11	S21316001	1	ワイヤストツパー	WIRE STOPPER	
2-12	012400432	1	アナヒラ4X4	SET SCREW, SOCKET (FT) M4X4	
2-13	S23349001	1	レハチヨウセツイタ	LEVER ADJUSTING PLATE	
2-14	060400812	2	ハインド M4X8	SCREW, BIND M4X8	
2-15	S39796001	1	スペース	SPACER	
2-16	060400812	1	ハインド M4X8	SCREW, BIND M4X8	
2-17	011502012	2	トメネシ 5X20ヒラ	SET SCREW, (FT) M5X20	
2-18	021500312	2	3シユナツト5	NUT, 3 M5	

M420
M620
W420
W620

< 半沈用 / For Semi-submerged >

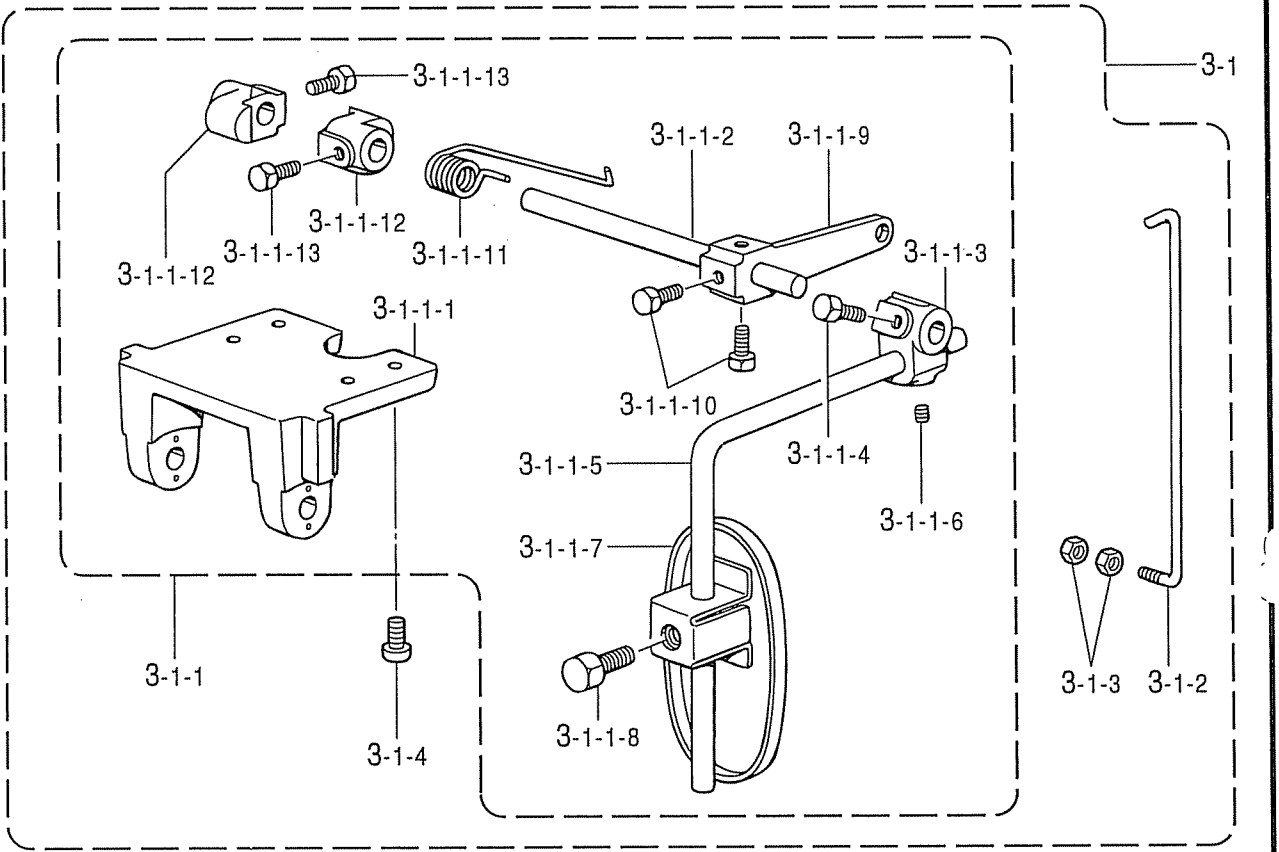

< 全沈用 / For Fully-submerged >

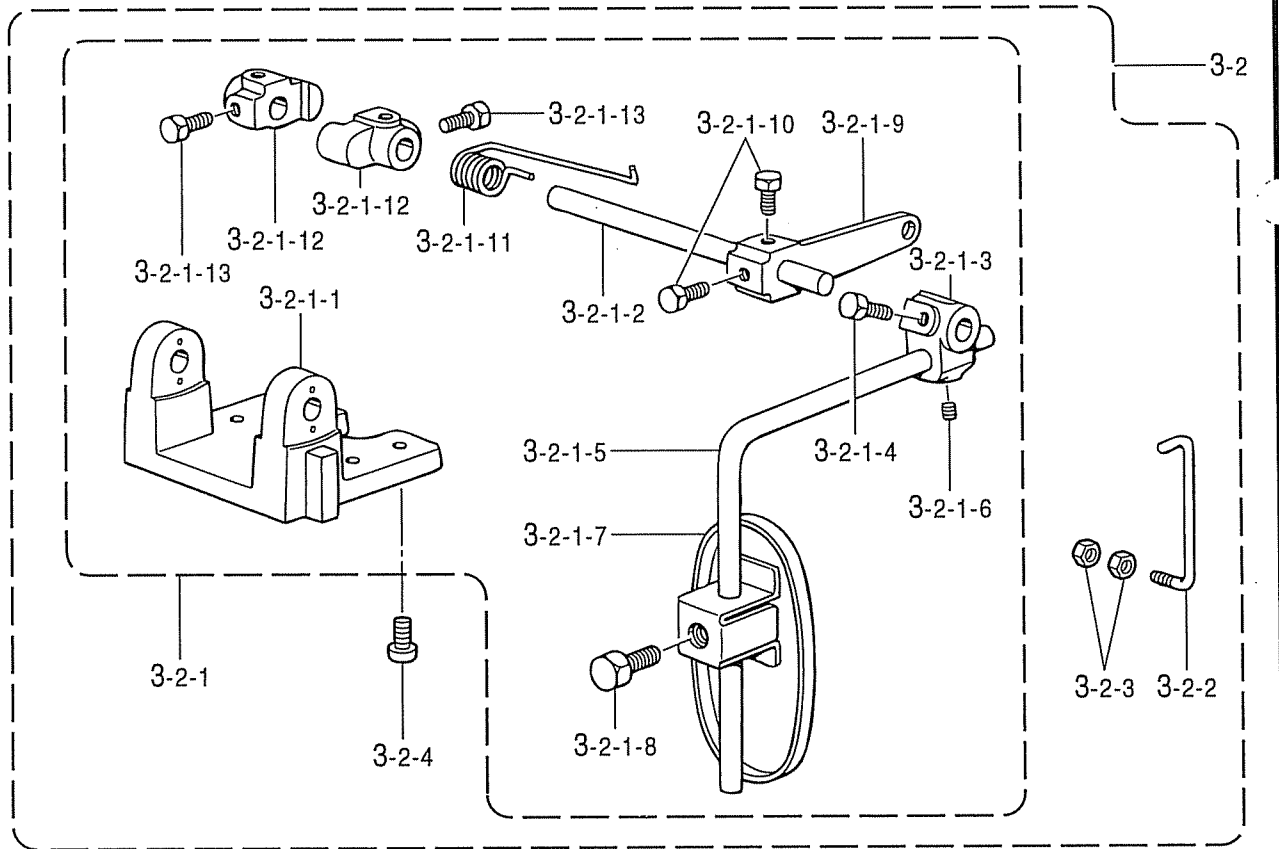

P2. ラフラー装置関係 / Ruffling attachment

REF.NO	CODE	QTY	ヒンメイ	NAME OF PARTS	RM
			<半沈用>	<For Semi-submerged>	
3-1	S30135101	1	サトウチヨウセツセツト	DIFFERENTIAL ADJUSTING SET	
3-1-1	S21373101	1	サトウチヨウセツツウチクミ	DIFFERENTIAL FEED ADJUSTER	
3-1-1-1	155197101	1	ヒサアテヨコシクウケ	KNEE LIFTER SHAFT BRACKET	
3-1-1-2	S21375001	1	ヨコシク	KNEE LIFTER SHAFT	
3-1-1-3	155199101	1	ヒサアテツキテ	BRACKET, KNEE LIFTER	
3-1-1-4	017781412	2	ボルト6.35X14	BOLT, SM6.35X14	
3-1-1-5	148797001	1	ヒサアケタテシクS	KNEE LIFTER BAR, S	
3-1-1-6	014780622	1	アトメネシ6.35クホミ	SET SCREW, SOCKET (CP) SM6.35	
3-1-1-7	148798109	1	ヒサアテL	KNEE LIFTER PLATE, L	
3-1-1-8	017081606	1	ボルト8X16	BOLT, M8X16	
3-1-1-9	S21376001	1	ヒサアテレハ-	KNEE LIFTER LEVER	
3-1-1-10	017781412	2	ボルト6.35X14	BOLT, SM6.35X14	
3-1-1-11	S21377001	1	ヒサアテレハ-ハネ	SPRING, TWIST	
3-1-1-12	S21378001	2	ヨコシクトメク	COLLAR	
3-1-1-13	017781412	4	ボルト6.35X14	BOLT, SM6.35X14	
3-1-2	S21379001	1	ヒサアテリンク	CONNECTING BAR	
3-1-3	021400202	2	2シユナツト4	NUT, 2 M4	
3-1-4	062401012	4	ナハコM4X10	SCREW, PAN M4X10	
			<全沈用>	<For Fully-submerged>	
3-2	S30135102	1	サトウチヨウセツセツト	DIF.ADJUSTING SET, FULL	
3-2-1	S21380101	1	サトウチヨウセツツウチクミ	DIFFERENTIAL FEED ADJUSTER	
3-2-1-1	155197101	1	ヒサアテヨコシクウケ	KNEE LIFTER SHAFT BRACKET	
3-2-1-2	S21375001	1	ヨコシク	KNEE LIFTER SHAFT	
3-2-1-3	155199101	1	ヒサアテツキテ	BRACKET, KNEE LIFTER	
3-2-1-4	017781412	2	ボルト6.35X14	BOLT, SM6.35X14	
3-2-1-5	148797001	1	ヒサアケタテシクS	KNEE LIFTER BAR, S	
3-2-1-6	014780622	1	アトメネシ6.35クホミ	SET SCREW, SOCKET (CP) SM6.35	
3-2-1-7	148798109	1	ヒサアテL	KNEE LIFTER PLATE, L	
3-2-1-8	017081606	1	ボルト8X16	BOLT, M8X16	
3-2-1-9	S21376001	1	ヒサアテレハ-	KNEE LIFTER LEVER	
3-2-1-10	017781412	2	ボルト6.35X14	BOLT, SM6.35X14	
3-2-1-11	S21377001	1	ヒサアテレハ-ハネ	SPRING, TWIST	
3-2-1-12	S21378001	2	ヨコシクトメク	COLLAR	
3-2-1-13	017781412	4	ボルト6.35X14	BOLT, SM6.35X14	
3-2-2	S21381001	1	ヒサアテリンク	CONNECTING BAR	
3-2-3	021400202	2	2シユナツト4	NUT, 2 M4	
3-2-4	062401012	4	ナハコM4X10	SCREW, PAN M4X10	

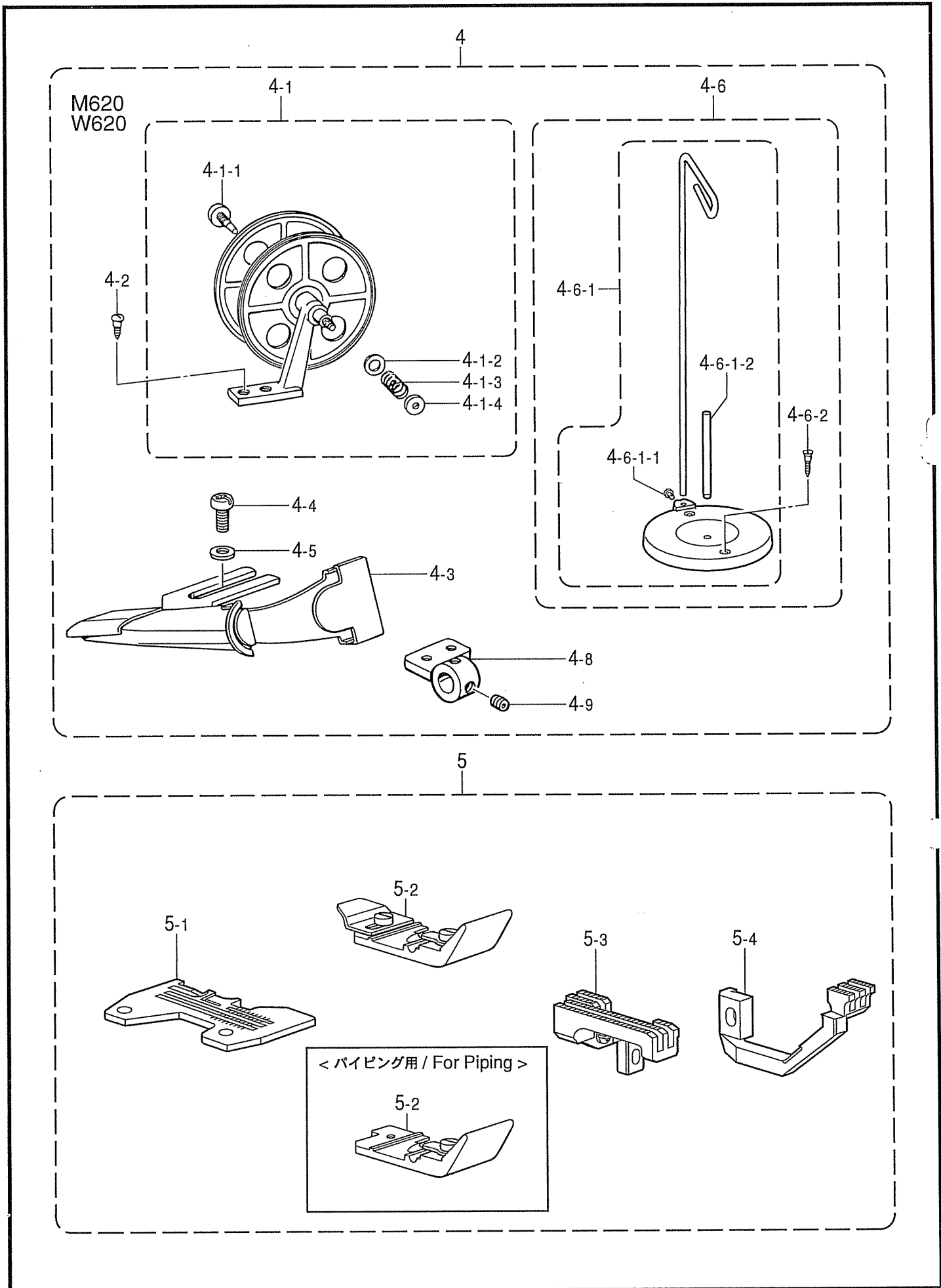

P3. ラフラー装置関係 / Ruffling attachment

REF.NO	CODE	Q'TY	ヒンメイ	NAME OF PARTS	RM
4	S30303001	1	ハ°化°ンク°ハ°ツクミ	PIPING PARTS ASSY	
4-1	143767102	1	テープ°ワインダ°ークミ	TAPE WINDER ASSY	
4-1-1	143980001	1	ツミネジ°	SCREW	
4-1-2	108494001	1	サ°ガ°ネ	WASHER	
4-1-3	108495001	1	テープ°ワインダ°オシハ°ネ	SPRING, COMPRESSION	
4-1-4	100136001	1	トチヨウ°シナツト	NUT, TENSION	
4-2	101118001	2	マルモク°ネジ° 4.5X20	WOOD SCREW, ROUND M4.5X20	
4-3	S21318000	1	ラツハ°ークミ	LAPPER ASSY	
4-4	062400812	2	ナ°ハ°コ4X8	SCREW, PAN M4X8	
4-5	025040232	2	ヒラサ°ガ°ネ°ユウ4	WASHER, PLAIN M 4	
4-6	S20130009	1	トチタ°イ°クミ°ネジ°ツキ	COTTON STAND ASSY, W/SCREW	
4-6-1	S20131009	1	トチタ°イ°クミ	COTTON STAND ASSY	
4-6-1-1	S20134001	1	シメ°ネジ° W476-24X10	SCREW, W4.76-24X10	
4-6-1-2	S20135001	1	トチタ°ホ°ウ	SPOOL PIN	
4-6-2	034422006	2	+2サラモク°41X20	WOOD SCREW, FLAT 2 M4.1X20	
4-8	S25019001	1	ラツハ°ー°ト°ダイ	LAPPER BASE	
4-9	S23651002	2	ア°ハ°ヒ°ラ°6X6°ホ°ソメ	SET SCREW, SOCKET (FT) M6X5	

5	S30291001	1	ラフラー°ゲ°ー°ジ°クミ	RUFFLER GAUGE ASSY	
5-1	S19162001	1	ハリタ	NEEDLE PLATE	
5-2	S19291001	1	オサエ°クミ	PRESSER FOOT ASSY	
5-3	S19500001	1	シヨクリハ°クミ	MAIN FEED DOG ASSY	
5-4	S19243001	1	サ°ウ°クリハ° <ハ°化°ンク°用>	DIFFERENTIAL FEED DOG <For Piping>	
5	S30292001	1	P.ラフラー°ゲ°ー°ジ°クミ	PIPING RUFFLER GAUGE ASSY	
5-1	S19162001	1	ハリタ	NEEDLE PLATE	
5-2	S25538001	1	オサエ°クミ	PRESSER FOOT ASSY	
5-3	S19500001	1	シヨクリハ°クミ	MAIN FEED DOG ASSY	
5-4	S19243001	1	サ°ウ°クリハ°	DIFFERENTIAL FEED DOG	

	REF.NO	W420-25, M420-25		W620-25, M620-25	
		半沈	全沈	半沈	全沈
		Semi-submerged	Fully-submerged	Semi-submerged	Fully-submerged
ラフラー°シヨウ°セット Ruffler set		S43535-001	S43537-001	-	-
P.ラフラー°シヨウ°セット Piping ruffler set		-	-	S43536-001	S43538-001
ラフラー°クミ Ruffler assy	1	S30134-001	←	←	←
ラフラー°オサエ°レンド°ウ°クミ Ruffling device set	2	S43530-001	←	←	←
サドウ°チヨウ°セツ°セット Differential adjusting set	3	S30135-101	S30135-102	S30135-101	S30135-102
パイピング°パーツ°クミ Piping parts assy	4	-	-	S30303-001	←
ラフラー°ゲ°ー°ジ°クミ Ruffler gauge assy	5	S30291-001	←	-	-
P.ラフラー°ゲ°ー°ジ°クミ Piping ruffler gauge assy	5	-	-	S30292-001	←

Z1. 付属品関係 / Accessories

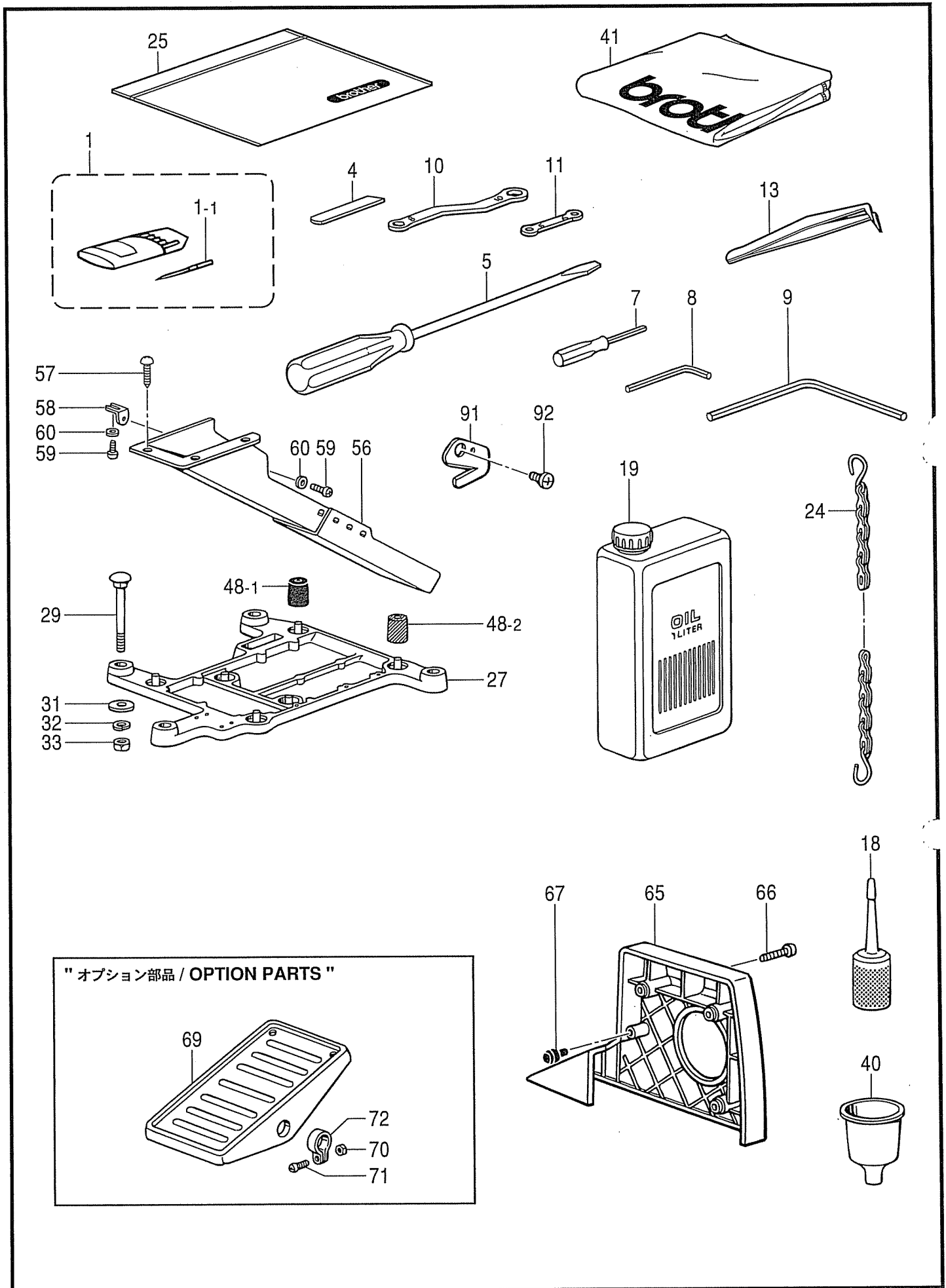

Z1. 付属品関係 / Accessories

REF.NO	CODE	QTY	ヒンメイ	NAME OF PARTS	RM
1	*	2	ミシンハリクミ	NEEDLE ASSY	
1-1	*	8	ミシンハリ	NEEDLE	
4	*	1	シタメス	LOWER KNIFE, T=1.5	
5	101572101	1	ネジ マフシ5. 5X190	SCREW DRIVER, 5.5X190	
7	S01943001	1	6カホウウネジ マフシ1.6	SCREW DRIVER, HEX. 1.6	
8	142002001	1	6カホウウスハナ2	HEXAGONAL WRENCH, 2	
9	149570001	1	6カホウウスハナ5	HEXAGONAL WRENCH, 5	
10	S23356001	1	メガネレンチ8X10	DOUBLE WRENCH, 8X10	
11	S46907001	1	メガネレンチ5X6	WRENCH, 5X6	
13	117466000	1	ピンセット	PINCETTE	
18	S06701000	1	ポリオイラークミ	POLY OILER ASSY	
19	S55666002	1	オイルタンクBクミ	OIL TANK ASSY, B	
24	142262001	1	チェーンFクミ	CHAIN ASSY, F	
25	122991001	1	フックヒンボリフクロ	ACCESSORY BAG	
27	S20718000	1	トウフウカ	HEAD PLATE	
29	S35997001	4	カネボルト8X85	BOLT, M8X85	
31	213650001	4	ワ2. 3X8. 5X38ST	WASHER, 2.3X8.5X38ST	
32	028080242	4	ハネサカネ2-8	WASHER, SPRING 2-8	
33	021080106	4	ナット1シ18	NUT, 1 M8	
40	S20769000	1	シヨコ	FUNNEL	
41	144225002	1	トウフウカバー	HEAD COVER	
48-1	147919051	1	ホウシンゴム	RUBBER CUSHION	
48-2	147919052	3	ホウシンゴム	RUBBER CUSHION	
56	183797009	1	ダスターシュートクミ	DUSTER CHUTE ASSY	
57	031411304	3	丸モクネジ 4. 1X13	WOOD SCREW, ROUND M4.1X13	
58	S23353001	1	ダスターシュートササIS	DUSTER SHOOT SUPPORT, S	
59	062400612	2	ナベコM4X6	SCREW, PAN M4X6	
60	025040332	2	ヒラサカネタ14	WASHER, PLAIN L 4	
65	S38302020	1	ベルトカバー	BELT COVER	
66	062061412	3	ナベコM6X14	SCREW, PAN M6X14	
67	S20412000	1	ゴムセン3.7	RUBBER CAP, 3.7	
69	147893009	1	”オプション部品” オサアケフミタ	"OPTION PARTS" TREADLE PEDAL	
70	021400106	2	ナット1シ14	NUT, 1 M4	
71	062401406	2	ナベコM4X14	SCREW, PAN M4X14	
72	116016001	2	ペダル止め	PEDAL STOPPER	
71	S20118151	1	カラヌイメス	TRIMMING KNIFE	
72	060300512	1	ハイト M3X5	SCREW, BIND M3X5	

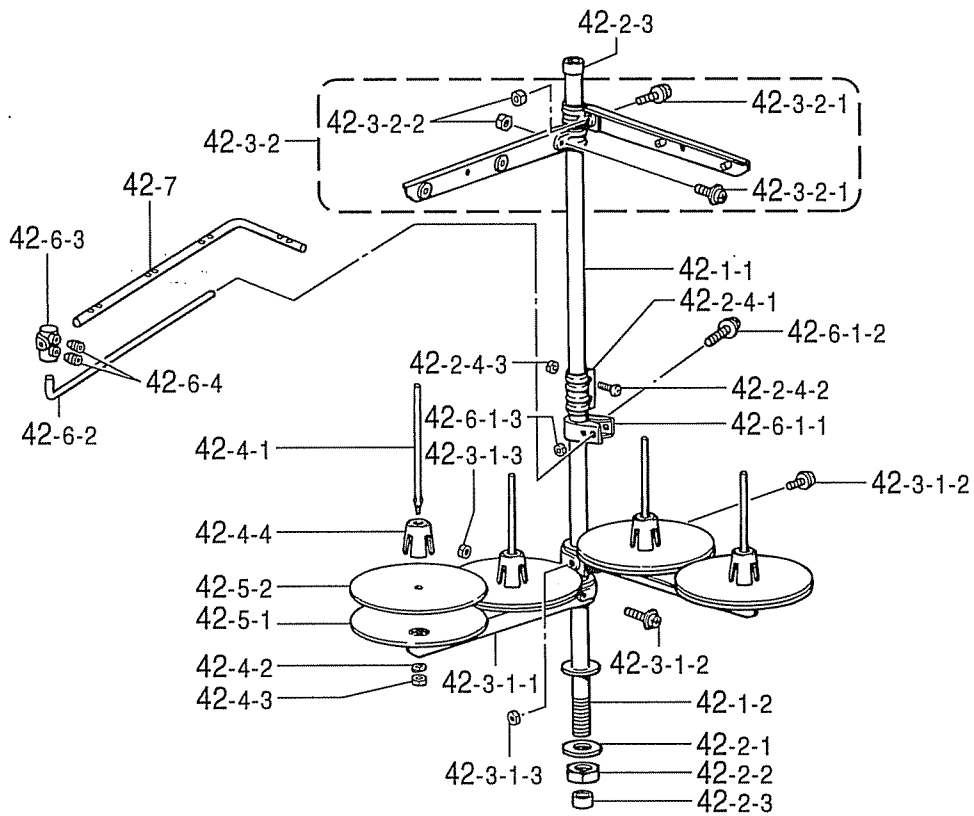

" オプション部品 / OPTION PARTS "

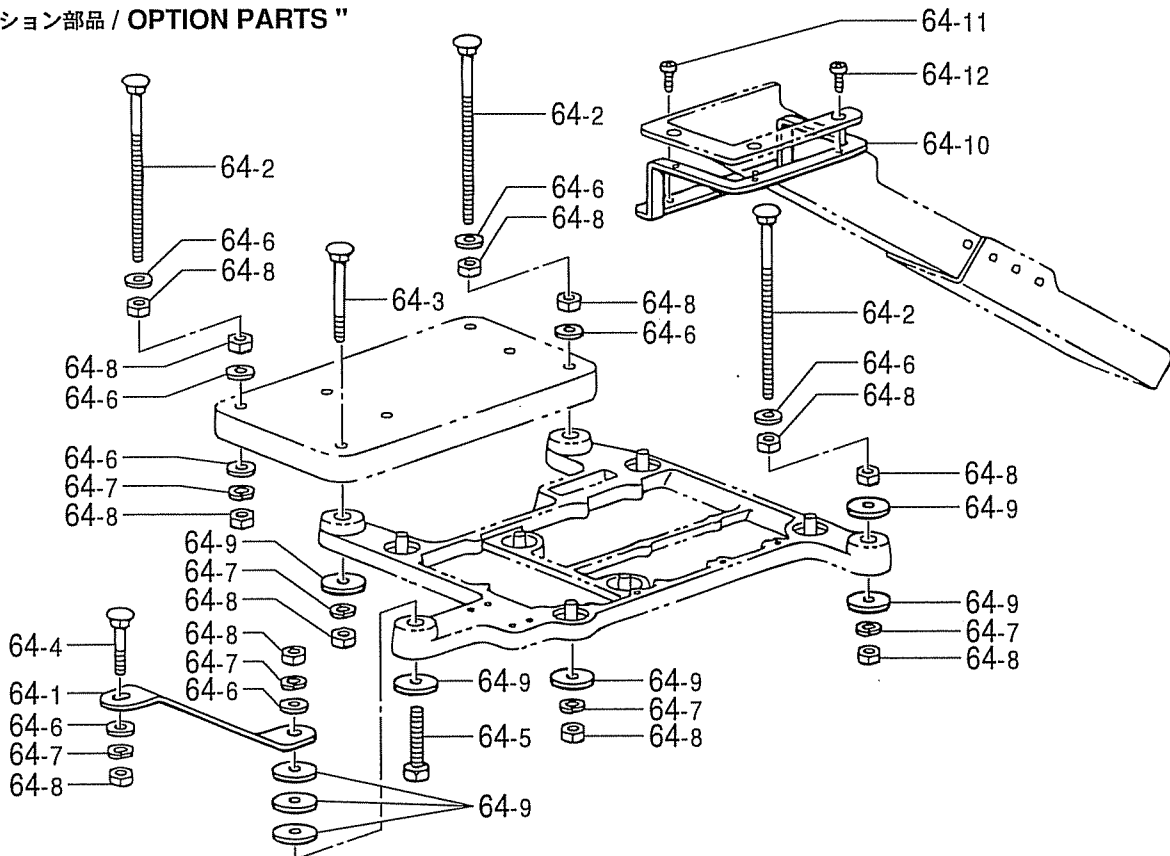









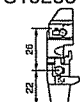

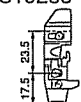
Z2. 付属品関係 / Accessories

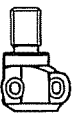
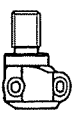
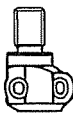

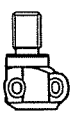
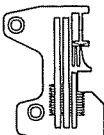
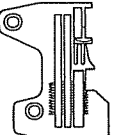
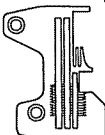
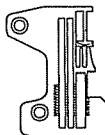
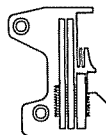
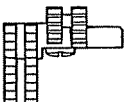
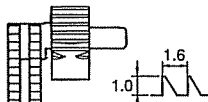
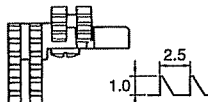
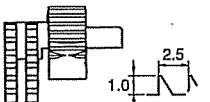
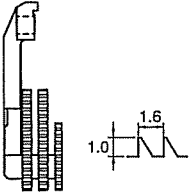
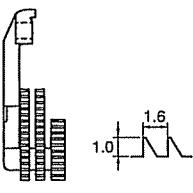
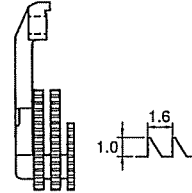
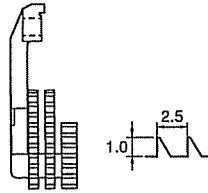
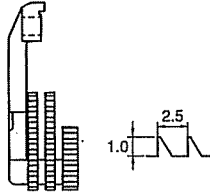
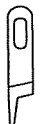
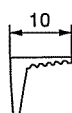

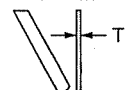



REF.NO	CODE	QTY	ヒンメイ	NAME OF PARTS	RM
42	S45952001	1	イトテタ`イクミ4DTHF	COTTON STAND ASSY, 4DTHF	
42-1	S45955001	1	コラム`イブ`セット	COLUMN PIPE SET	
42-1-1	150172023	1	コラム`イブ`	COLUMN PIPE	
42-1-2	S36064021	1	コラム`イブ`D	COLUMN PIPE, D	
42-2	S45956001	1	ジ`ヨイント`セット	JOINT SET	
42-2-1	150206022	1	ヒラサ`カ`ネ16	WASHER, PLAIN 16	
42-2-2	S36062021	1	6カケナツトM16	NUT, M16	
42-2-3	S35635020	2	コラム`キャツフ`	COLUMN CAP	
42-2-4	S35828021	1	コラム`ジ`ヨイント`クミ	COLUMN JOINT ASSY	
42-2-4-1	150173023	1	コラム`ジ`ヨイント`	COLUMN JOINT	
42-2-4-2	S35826021	2	ナ`コ5X14	SCREW, PAN M5X14	
42-2-4-3	S35827021	2	1シユナツト5	NUT, 1 M5	
42-3	S45968001	2	ホルタ`セット2	HOLDER SET, 2	
42-3-1	S45969001	2	スプ`-ルホルタ`-クミ2	SPOOL HOLDER ASSY, 2	
42-3-1-1	S02778022	2	スプ`-ルホルタ`-2	SPOOL HOLDER, 2	
42-3-1-2	S35831021	2	ナ`サ`クミ5X30A	SCREW, PAN (S/P WASHER) M5X30	
42-3-1-3	S35827021	2	1シユナツト5	NUT, 1 M5	
42-3-2	S45970001	2	スレツト`ハンカ`-クミ2	THREAD HANGER ASSY, 2	
42-3-2-1	S35832021	2	ナ`サ`クミ5X14A	SCREW, PAN (S/P WASHER) M5X14	
42-3-2-2	S35827021	2	1シユナツト5	NUT, 1 M5	
42-4	S45971001	2	スプ`-ルネジ`セット2	SPOOL SCREW SET, 2	
42-4-1	150179022	4	スプ`-ルシ`ク`B	SPOOL SHAFT, B	
42-4-2	028050246	4	ハ`ネサ`カ`ネ2-5	WASHER, SPRING 2-5	
42-4-3	S35827021	4	1シユナツト5	NUT, 1 M5	
42-4-4	126863021	4	スプ`-ルクツシヨ`ン	SPOOL CUSHION	
42-5	S45972001	2	ウケサ`ラ`セット2	SPOOL STAND BASE SET	
42-5-1	150180021	4	ウケサ`ラ`	SPOOL STAND BASE	
42-5-2	150182020	4	スプ`-ルマツト	SPOOL MAT	
42-6	S45960001	1	イトアンナイホルタ`セット	THREAD GUIDE HOLDER SET	
42-6-1	S45967001	1	イトアンナイホルタ`クミ	THREAD GUIDE HOLDER ASSY	
42-6-1-1	150185009	1	イトアンナイホルタ`-	THREAD GUIDE HOLDER	
42-6-1-2	S35831021	1	ナ`サ`クミ5X30A	SCREW, PAN (S/P WASHER) M5X30	
42-6-1-3	S35827021	1	1シユナツト5	NUT, 1 M5	
42-6-2	S04109001	1	イトアンナイササ`イホ`ウ	SUPPORT BAR, ;TR-GUIDE	
42-6-3	S45961001	1	ササ`イホ`ウツキ`テ	JOINT	
42-6-4	012060632	2	ア`ナ`ヒラ6X6	SET SCREW, SOCKET (FT) M6X6	
42-7	142998101	1	イトアンナイ4	THREAD GUIDE, 4	
64	183798001	1	フルサフ`マ`-ジ`セット	"OPTION PARTS" FULL SUBMERGED SET	
64-1	S20721001	1	トウフ`ウケサ`サ`I	HEAD PLATE SUPPORT	
64-2	153318201	4	カクネ`ル`ア`タ`マ`ホ`ルト	BOLT	
64-3	S35997001	1	カクネ`ホ`ルト8X85	BOLT, M8X85	
64-4	S36007001	1	カクネ`ホ`ルト8X55	BOLT, M8X55	
64-5	017085502	1	ホ`ルトM8X55	BOLT, M8X55	
64-6	025080236	11	ヒラサ`カ`ネチユ8	WASHER, PLAIN M 8	
64-7	028080242	7	ハ`ネサ`カ`ネ2-8	WASHER, SPRING 2-8	
64-8	021080106	15	ナツト1シユ8	NUT, 1 M8	
64-9	213650001	8	ワ`2. 3X8. 5X38ST	WASHER, 2.3X8.5X38ST	
64-10	S20722001	1	タ`スタ`-シユト`サ`サ`I	DUSTER SHOOT SUPPORT, L	
64-11	060400812	2	ハ`イント`M4X8	SCREW, BIND M4X8	
64-12	060400812	3	ハ`イント`M4X8	SCREW, BIND M4X8	

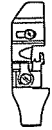
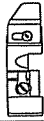

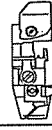
Ga1 . ゲージ部品一覧表 / Gauge parts List

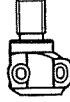
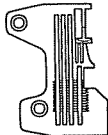
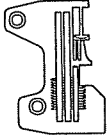
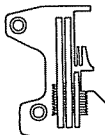
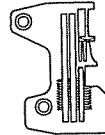
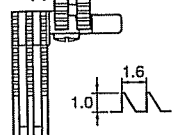
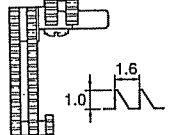
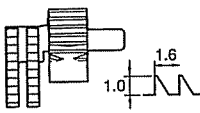
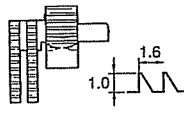
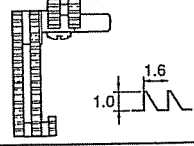
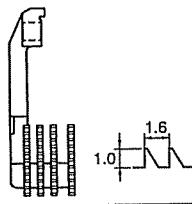
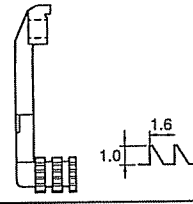
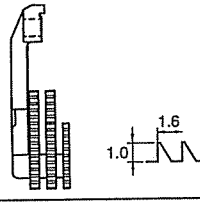
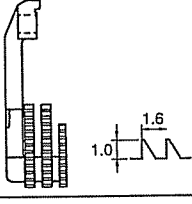
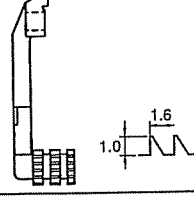
下の表は サブクラスの番号順に 並べてあります

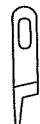

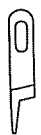
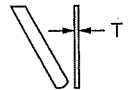
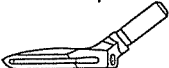

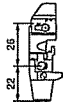
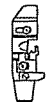
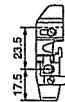
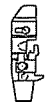
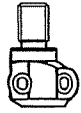
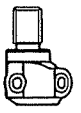
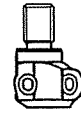
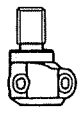
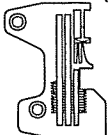
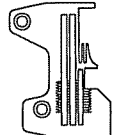
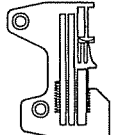
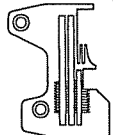
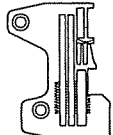
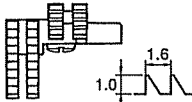
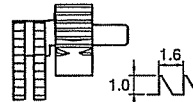
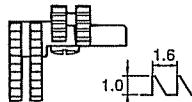
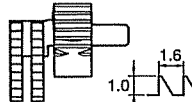
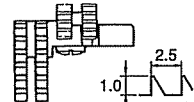
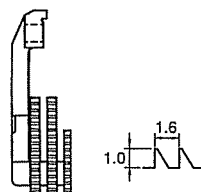
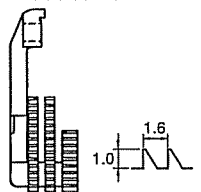
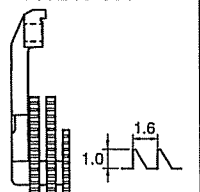
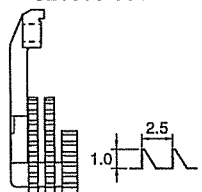
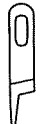
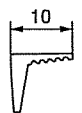
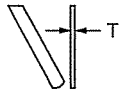
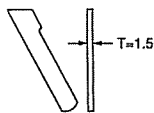

用途 Application	一般地縫用 Thin Medium (1本外シ) (Mock-Safety)		一般地縫用 Thin Medium (小回り用) (For small type) (1本外シ) (Mock-Safety)	デニム用 Heavy (1本外シ) (Mock-Safety)	バルキーニット用 Bulky knit (1本外シ) (Mock-Safety)
サブクラス Sub-Class	M020-24-H3F -25-H3F -26-H3F -27-H3F	M020-35-H3F -36-H3F -37-H3F	M021-25-H8F -26-H8F -27-H8F	M040-36-E3W -37-E3W	M060-25-H8V -26-H8V -27-H8V
針巾 (mm) Needle Gauge	2.2	3	2.2	3	2.2
1 針 Needle	151474-011			151474-018	151474-014
2 押工組 Presser Foot Assy (ツメ Stitch Tongue)	S25543-001 (4) (S25544-001) S19280-001 (5) (S19976-001) S19282-001 (6,7) (S19283-001) 	S19284-001 (5) (S19976-001) S19285-001 (6) (S19286-001) S19289-001 (7) (S19975-001) 	S29952-001 (4) (S25544-001) S29950-001 (5) (S19976-001) S29951-001 (6,7) (S19283-001) 	S29871-001 (6) (S19286-001) S29869-001 (7) (S19975-001) 	S19287-201 (5) (S19976-001) S19288-201 (6,7) (S19283-001) 
3 針止め組 Needle Clamp Assy	S20398-001 	S20402-001 	S20398-001 	S20402-001 	S20398-001 
4 針板 Needle Plate	S25190-001 (4) S19162-001 (5) S19163-001 (6) S25191-001 (7) 	S19164-001 (5) S19165-001 (6) S19168-001 (7) 	S25527-001 (4) S19169-001 (5) S19170-001 (6) S25193-001 (7) 	S24663-001 (6) S24664-001 (7) 	S19166-001 (5) S19167-001 (6) S25192-001 (7) 
5 主送り歯組 Main Feed Dog Assy (主送り歯 Main Feed Dog) (補助送り歯 Chain Feed Dog)	S19199-001 (S19200-001) (S19201-001) A 		S19212-001 (S19213-001) (S19204-001) B 	S21392-001 (S21393-001) (S21394-001) J 	S19202-001 (S19955-001) (S19204-001) B 
6 差動送り歯 Differential Feed Dog	S19236-001 	S19242-001 	S19240-001 	S21395-001 	S19237-101 
7 上メス Upper Knife	上メス Upper knife 144074-350 			角メス Angle knife S20898-101 	角メス Angle knife S20897-101 
8 下メス Lower Knife 	S20582-001 (T=1.5)	(5) S20899-001 (T=1.0) (6,7) S20582-001 (T=1.5)	S20582-001 (T=1.5)	S20583-001 	(5) S20899-001 (T=1.0) (6,7) S20582-001 (T=1.5)
9 上ルーパ Over Looper 	S20436-001 F	S20434-001 E	S20436-001 F	S20442-001 R	S20434-001 E

Ga2 . ゲージ部品一覧表 / Gauge parts List

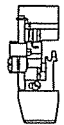
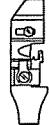

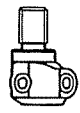
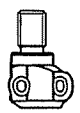
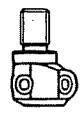
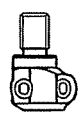
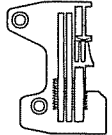
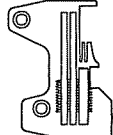
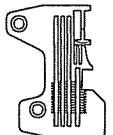
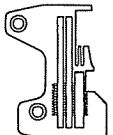
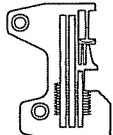
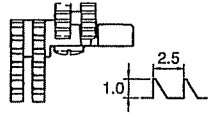
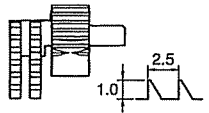
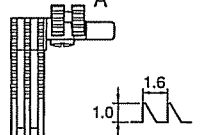
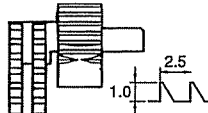
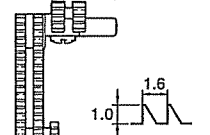
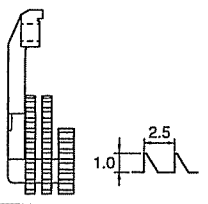
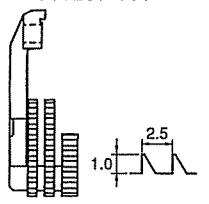
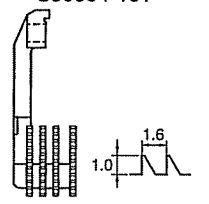
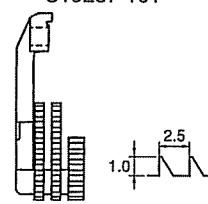
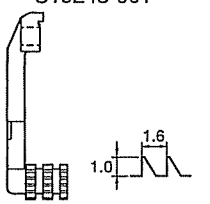
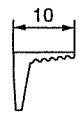

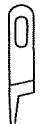
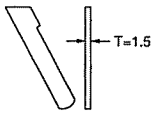



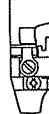

用途 Application	バルキーニット用 Bulky knit (1本外シ) (Mock-Safety)	ラフラー用 (1本外シ) Ruffling (Mock-Safety)	テープ用 Taping (1本外シ) (Mock-Safety)	バルキーニット(テープ用) Bulky knit (Taping) (1本外シ) (Mock-Safety)	パイピングラフラー用 Ruffling W / Piping (1本外シ) (Mock-Safety)
サブクラス Sub-Class	M060-25-H4V -26-H4V -27-H4V	M420-25-H3F	M520-25-H8F -26-H8F	M560-25-H8V -26-H8V -27-H8V	M620-25-H3F -26-H3F
針巾 (mm) Needle Gauge	2.2				
1 針 Needle	151474-014	151474-011		151474-014	151474-011
2 押工組 Presser Foot Assy (ツメ Stitch Tongue)	S19287-201 (5) (S19976-001) S19288-201 (6,7) (S19283-001) 	S19291-001 	S19293-001 (5) (S19974-001) S25546-001 (6) (S25547-001) 	S19297-001 (5) (S19976-001) S19301-001 (6,7) (S19283-001) 	S25538-001 
3 止め組 Needle Clamp Assy	S20398-001 				
4 針板 Needle Plate	S25528-001 (5) S19188-001 (6) S25529-001 (7) 	S19162-001 	S19169-001 (5) S19170-001 (6) S25193-001 (7) 	S19162-001 (5) S19163-001 (6) 	
5 主送り歯組 Main Feed Dog Assy (主送り歯 Main Feed Dog) (補助送り歯 Main Feed Dog)	S24680-001 (S24681-001) (S19201-001) A 	S19500-001 (S19218-001) (S19201-001) A 	S19212-001 (S19213-001) (S19204-001) B 	S19219-001 (S19220-001) (S19204-001) B 	S19500-001 (S19218-001) (S19201-001) A 
6 差動送り歯 Differential Feed Dog	S30894-101 	S19243-001 	S19240-001 	S19244-101 	S19243-001 
7 上メス Upper Knife	角メス Angle knife S20897-101 	上メス Upper knife 144074-350 		角メス Angle knife S20897-101 	上メス Upper knife 144074-350 
8 下メス Lower Knife 	(5) S20899-001 (T=1.0) (6,7) S20582-001 (T=1.5)	S20582-001 (T=1.5)			
9 上ルーパ Over Looper 	S20434-001 E	S20436-001 F		S20434-001 E	S20436-001 F

用途 Application	一般地縫用 Thin Medium		一般地縫用 Thin Medium	一般地縫用 Thin Medium (小回り用) (For small type)	デニム用 Heavy
	チェーンランドあり With Chain Land	チェーンランドなし Without Chain Land			
サブクラス Sub-Class	W020-24-H3F -25-H3F -26-H3F -27-H3F	W020-24-H8F -25-H8F -26-H8F -27-H8F	W020-35-H3F -36-H3F -37-H3F	W021-24-H8F -25-H8F -26-H8F -27-H8F	W040-36-E3W -37-E3W
針巾 (mm) Needle Gauge	2.2		3	2.2	3
1 針 Needle	151474-011				151474-018
2 押工組 Presser Foot Assy (ツメ Stitch Tongue)	S25543-001 (4) (S25544-001) S19280-001 (5) (S19976-001) S19282-001 (6, 7) (S19283-001) 	S19284-001 (5) (S19976-001) S19285-001 (6) (S19286-001) S19289-001 (7) (S19975-001) 	S29952-001 (4) (S25544-001) S29950-001 (5) (S19976-001) S29951-001 (6, 7) (S19283-001) 	S29871-001 (6) (S19286-001) S29869-001 (7) (S19975-001) 	
3 針止め組 Needle Clamp Assy	S20398-001 		S20402-001 	S20398-001 	S20402-001 
4 針板 Needle Plate	S25190-001 (4) S19162-001 (5) S19163-001 (6) S25191-001 (7) 	S25527-001 (4) S19169-001 (5) S19170-001 (6) S25193-001 (7) 	S19164-001 (5) S19165-001 (6) S19168-001 (7) 	S25527-001 (4) S19169-001 (5) S19170-001 (6) S25193-001 (7) 	S24663-001 (6) S24664-001 (7) 
5 主送り歯組 Main Feed Dog Assy (主送り歯 Main Feed Dog) (補助送り歯 Chain Feed Dog)	S19217-001 (S19213-001) (S19201-001) A 	S19212-001 (S19213-001) (S19204-001) B 	S19199-001 (S19200-001) (S19201-001) A 	S19212-001 (S19213-001) (S19204-001) B 	S21392-001 (S21393-001) (S21394-001) J 
6 差動送り歯 Differential Feed Dog	S19240-001 	S19242-001 	S19240-001 	S21395-001 	
7 上メス Upper Knife	上メス Upper knife 144074-350 				角メス Angle knife S20898-101 
8 下メス Lower Knife 	S20582-001 (T=1.5)		(5) S20899-001 (T=1.0) (6, 7) S20582-001 (T=1.5)	S20582-001 (T=1.5)	S20583-001 
9 上ルーパ Over Looper 	S20424-001 B		S20432-001 J	S20424-001 B	S49054-001 S

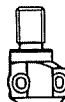
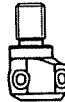
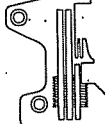
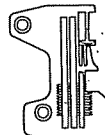
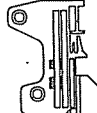
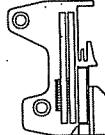
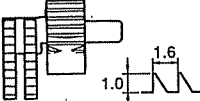
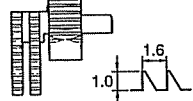
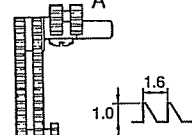
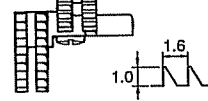
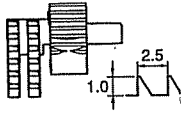
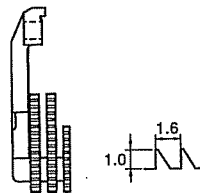
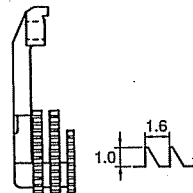
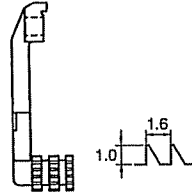
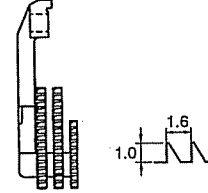
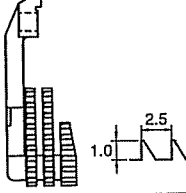

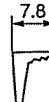
Ga4 . ゲージ部品一覧表 / Gauge parts List

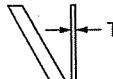
用途 Application	デニム用 Heavy (トラクター押工) (Tractor Type)	バルキーニット用 Bulky knit			ラフラー用 Ruffling
サブクラス Sub-Class	W050-36-E3W -37-E3W	W060-25-H8V -26-H8V -27-H8V	W060-25-H4V -26-H4V -27-H4V	W070-X6-E8V -X7-E8V	W420-25-H3F
針巾 (mm) Needle Gauge	3	2.2			2.2
1 針 Needle	151474-018	151474-014			151474-011
2 押工組 Presser Foot Assy (ツメ Stitch Tongue)	S30898-001 (S30900-001) 	S19287-201 (5) (S19976-001) S19288-201 (6, 7) (S19283-001) 		S19303-201 (6) (S19286-001) S20881-201 (7) (S19975-001) 	S19291-001 
針止メ組 Needle Clamp Assy	S20402-001 	S20398-001 		S20400-001 	S20398-001 
4 針板 Needle Plate	S24663-001 (6) S24664-001 (7) 	S19166-001 (5) S19167-001 (6) S25192-001 (7) 	S25528-001 (5) S19188-001 (6) S25529-001 (7) 	S19173-001 (6) S20880-001 (7) 	S19162-001 
5 主送り歯組 Main Feed Dog Assy (主送り歯 Main Feed Dog) (補助送り歯 Main Feed Dog)	S21392-001 (S21393-001) (S21394-001) J 	S19202-001 (S19955-001) (S19204-001) B 	S24680-001 (S24681-001) (S19201-001) A 	S19202-001 (S19955-001) (S19204-001) B 	S19500-001 (S19218-001) (S19201-001) A 
6 差動送り歯 Differential Feed Dog	S21395-001 	S19237-101 	S30894-101 	S19237-101 	S19243-001 
7 上メス Upper Knife	角メス Angle knife S20898-101 	角メス Angle knife S20897-101 			上メス Upper knife 144074-350 
8 下メス Lower Knife	S20583-001 	(5) S20899-001 (T=1.0) (6, 7) S20582-001 (T=1.5)		S20582-001 (T=1.5)	
9 上ルーパ Over Looper	S20438-101 G 	S20430-001 D		S20440-101 K	S20424-001 B

Ga5 . ゲージ部品一覧表 / Gauge parts List

用途 Application	テープ用 Taping	バルキーニット(テープ用) Bulky knit (Taping)	パイピングラフラー用 Ruffling W / Piping	バックタック用 Back-Tacking	バルキーニットバックタック用 Bulky knit Back-Tacking
サブクラス Sub-Class	W520-25-H8F -26-H8F	W560-25-H8V -26-H8V -27-H8V	W620-25-H3F -26-H3F	W820-25-H3F -26-H3F	W870-X6-E8V
針巾 (mm) Needle Gauge	2.2				2.5
1 針 Needle	151474-011	151474-014	151474-011		151474-014
2 押工組 Presser Foot Assy (ツメ Stitch Tongue)	S19293-001 (5) (S19974-001) S25546-001 (6) (S25547-001) 	S19297-001 (5) (S19976-001) S19301-001 (6, 7) (S19283-001) 	S25538-001 	S19302-001 (5, 6) (S19977-001) 	S19303-201 (S19286-001) 
3 針止め組 Needle Clamp Assy	S20398-001 				S20400-001 
4 針板 Needle Plate	S19169-001 (5) S19170-001 (6) S25193-001 (7) 	S19162-001 (5) S19163-001 (6) 	S19981-001 (5) S19982-001 (6) 	S33529-001 	
5 主送り歯組 Main Feed Dog Assy (主送り歯 Main Feed Dog) (補助送り歯 Chain Feed Dog)	S19212-001 (S19213-001) (S19204-001) B 	S19219-001 (S19220-001) (S19204-001) B 	S19500-001 (S19218-001) (S19201-001) A 	S25007-001 (S25008-001) (S25009-001) K 	S33530-001 (S33531-001) (S19204-001) B 
6 差動送り歯 Differential Feed Dog	S19240-001 	S19244-101 	S19243-001 	S25010-001 	S33536-001 
7 上メス Upper Knife	上メス Upper knife 144074-350 	角メス Angle knife S20897-101 	上メス Upper knife 144074-350 	角メス Angle knife S20897-101 	
8 下メス Lower Knife 	S20582-001 (T=1.5)				
9 上ルーパ Over Looper 	S20424-001 B	S20430-001 D	S20424-001 B		S20440-101 K

Wa. 警告ラベル / Warning labels

警告ラベル / Warning labels	品名 / Name of parts	Size(mm)	Code
	操作注意ラベル・和	40 X 64	S38350-001
	Label, operation Eng.	40 X 64	S38349-001
	アースマーク Mark, grounding	φ 12	S37060-001

878-N21-052

索引 / INDEX

CODE	REF.NO	page	CODE	REF.NO	page	CODE	REF.NO	page
004350812	G 31	18	021060302	P1 1-1-20	34	060400612	A 50	2
011502012	J 1-29	24		P1 1-7	34		A 59	4
	P1 2-17	34	021080106	Z1 33	40		F1 10	12
012060632	A 43	2		Z2 64-8	42		G 22	18
	B 26	6	021400106	Z1 70	40		N 24	32
	B 25	6	021400202	P2 3-1-3	36		N 32	32
	F1 25	12		P2 3-2-3	36		N 36	32
	G 2	18	021400212	A 53	2		N 41	32
	G 6	18		E 1-5	10		N 43	32
	G 25-2	18		F1 18	12		N 45	32
	H 6-1	22		J 1-11	24	060400812	A 15	2
	K 6-1	26		P1 1-1-22	34		A 22-1	2
	M 17	30		P1 2-10	34		H 29	22
	P1 2-4	34	021500303	J 1-14-1	24		J 1-28	24
	Z2 42-6-4	42	021500312	J 1-30	24		M 24	30
012400432	A 27-4	2		P1 2-18	34		P1 2-14	34
	A 32	2	025030132	H 14	22		P1 2-16	34
	G 29	18	025040132	G 49	18		Z2 64-11	42
	J 1-13	24		H 11	22		Z2 64-12	42
	K 13	26		J 1-8	24	060401012	A 25-1	2
	M 4-2	30	025040232	J 1-19	24		D 1-3	1
	M 16	30		P3 4-5	38		J 1-9	2
	P1 2-12	34	025040332	Z1 60	40	060401412	A 28	2
012400832	A 31	2	025050132	A 72	4	060630412	F2 50-18-5	14
	G 32	18	025060332	F1 14	12	060630712	G 75-1	20
	J 1-7-4	24	025080236	Z2 64-6	42	061400812	A 26	2
012500532	M 2	30	025350332	A 68	4		B 6	6
014780622	P2 3-1-1-6	36		G 63	20		M 20	30
	P2 3-2-1-6	36	025710232	G 12	18	062060812	H 18	22
017060812	K 8	26		G 13	18		H 21	22
	L 7	28	026260136	F2 50-11-9	14	062061412	Z1 66	40
017061612	C 1-3-1	8	028050246	Z2 42-4-2	42	062300412	H 16-2	22
	H 1-2-1	22	028060242	B 27	6	062300512	E 1-7	10
017081606	P2 3-1-1-8	36	028080242	Z1 32	40		J 1-25	24
	P2 3-2-1-8	36		Z2 64-7	42	062300812	P1 1-1-11	34
017085502	Z2 64-5	42	031411304	Z1 57	40	062350512	P1 1-1-27	34
017500812	H 26	22	034422006	P3 4-6-2	38	062350612	E 1-9	10
017501212	A 64	4	047301242	G 1-1-1	18	062350812	C 7-3	8
017781412	P2 3-1-1-4	36		G 1-2-1	18		C 24	8
	P2 3-1-1-10	36	047301642	F1 2-2	12		P1 2-5	34
	P2 3-1-1-13	36	047401442	F1 21-1	12	062400612	A 30	2
	P2 3-2-1-4	36	047502542	F1 16	12		P1 1-1-25	34
	P2 3-2-1-10	36		G 57	20		Z1 59	40
	P2 3-2-1-13	36	047602042	A 54	2	062400812	A 9	2
018061432	G 53	18	048040342	G 14	18		B 5	6
	K 10	26	048090342	F1 27	12		M 4-6	30
	M 6	30		G 19	18		P1 1-1-16	34
018061632	F1 22	12	048400242	B 14	6		P3 4-4	38
	G 8-1	18	060300412	F1 35	12	062401012	A 4	2
	G 34	18		N 30	32		B 22	6
	G 40-1	18	060300512	Z1 92	40		C 20	8
	G 60	20	060300612	F1 43	12		E 2	10
018062532	B 28	6		N 52	32		P2 3-1-4	36
	C 16	8	060350812	A 67	4		P2 3-2-4	36
	F1 13	12		G 62	20	062401212	A 52	2
018400832	A 20	2	060351012	L 15	28		H 10-1	22
	G 48-2	18	060400512	A 60	4		J 1-20	24
018401222	P1 1-2	34	060400612	A 12	2		M 4-9	30
018401622	C 1-1	8		A 27-7	2	062401406	Z1 71	40
	H 1-1	22		A 27-9	2	062401612	A 81	4
	K 1-1	26		A 34	2		H 10-2	22
	L 1-1	28		A 36	2		P1 1-1-21	34
	L 1-1	28		A 46	2	062630612	F2 50-11-6	14

CODE	REF.NO	page
062670712	F1 41	12
	F2 50-25-9	16
072600000	B 7	6
076203000	B 15	6
081005070	G 11	18
081005670	G 56	20
081009070	A 78	4
081014670	A 6	2
081020070	G 21	18
081031870	B 4	6
100032003	A 40	2
	C 33	8
100136001	P3 4-1-4	38
100315002	A 41	2
101118001	P3 4-2	38
101572101	Z1 5	40
102707002	P1 1-8	34
104450101	C 11	8
105161004	F1 3	12
105288001	F2 50-10-5	14
106640001	F2 50-9-2	14
	F2 50-14-2	16
108494001	P3 4-1-2	38
108495001	P3 4-1-3	38
110832009	N 12	32
116016001	Z1 72	40
116794001	J 1-7-7	24
117466000	Z1 13	40
118550001	K 14	26
118735002	C 1-3-2	8
	H 1-2-2	22
122991001	Z1 25	40
126863021	Z2 42-4-4	42
140530002	F2 50-1-7	14
	F2 50-9-4	14
	F2 50-10-7	14
	F2 50-11-8	14
	F2 50-2-5	14
	F2 50-19-7	16
11183000	A 39	2
142002001	Z1 8	40
142262001	Z1 24	40
142998101	Z2 42-7	42
143767102	P3 4-1	38
143980001	P3 4-1-1	38
144074350	Ga1 7	43
	Ga2 7	44
	Ga4 7	46
	Ga5 7	47
	H 15-1	22
144103009	N 13	32
144225002	Z1 41	40
144784001	P1 1-1-10	34
146293001	C 6	8
146427001	C 12-1	8
	N 47	32
146592001	N 21	32
146598001	A 71	4
	E 1-3	10
146762001	E 1-8	10
147893009	Z1 69	40
147919051	Z1 48-1	40
147919052	Z1 48-2	40

CODE	REF.NO	page
147942001	M 8-1	30
	M 10-1	30
	M 13-1	30
148084001	M 18	30
148782001	L 13	28
148797001	P2 3-1-1-5	36
	P2 3-2-1-5	36
148798109	P2 3-1-1-7	36
	P2 3-2-1-7	36
149570001	Z1 9	40
150172023	Z2 42-1-1	42
150173023	Z2 42-2-4-1	42
150179022	Z2 42-4-1	42
150180021	Z2 42-5-1	42
150182020	Z2 42-5-2	42
150185009	Z2 42-6-1-1	42
150206022	Z2 42-2-1	42
150755001	F2 50-1-3	14
	F2 50-10-3	14
	F2 50-11-3	14
	F2 50-18-3	14
	F2 50-2-3	14
	F2 50-19-3	16
151474011	Ga1 1	43
	Ga2 1	44
	Ga3 1	45
151474014	Ga1 1	43
	Ga2 1	44
	Ga4 1	46
151474018	Ga1 1	43
	Ga3 1	45
153318201	Z2 64-2	42
154841001	A 76	4
155162001	C 7-6	8
	K 9-2-2	26
155197101	P2 3-1-1-1	36
	P2 3-2-1-1	36
155199101	P2 3-1-1-3	36
	P2 3-2-1-3	36
155247000	H 3	22
	K 11	26
	L 10	28
155559001	B 12	6
156482000	A 51	2
183797009	Z1 56	40
183798001	Z2 64	42
213650001	Z1 31	40
	Z2 64-9	42
S00075000	A 66	4
S01295001	F2 50-1-5	14
	F2 50-19-5	16
	F2 50-25-2	16
S01943001	Z1 7	40
S02573020	G 38	18
S02606020	A 3	2
S02778022	Z2 42-3-1-1	42
S04109001	Z2 42-6-2	42
S06701000	Z1 18	40
S06704001	D 1-4	10
S09234001	J 1-7-2	24
S09235001	J 1-7-3	24
S19162001	Ga1 4	43
	Ga2 4	44

CODE	REF.NO	page
S19162001	Ga2 4	44
	Ga3 4	45
	Ga4 4	46
	Ga5 4	47
	P3 5-1	38
S19163001	Ga1 4	43
S19163001	Ga2 4	44
	Ga3 4	45
	Ga5 4	47
	Ga1 4	43
S19165001	Ga1 4	43
S19166001	Ga1 4	43
S19166001	Ga4 4	46
	Ga1 4	43
S19167001	Ga4 4	46
	Ga1 4	43
S19169001	Ga1 4	43
S19169001	Ga2 4	44
	Ga3 4	45
	Ga5 4	47
	Ga1 4	43
S19170001	Ga2 4	44
	Ga3 4	45
	Ga5 4	47
	Ga4 4	46
S19188001	Ga2 4	44
S19188001	Ga4 4	46
	Ga1 5	43
S19199001	Ga3 5	45
	Ga1 5	43
S19200001	Ga3 5	45
	Ga1 5	43
S19201001	Ga2 5	44
	Ga2 5	44
	Ga2 5	44
	Ga3 5	45
	Ga3 5	45
	Ga3 5	45
	Ga4 5	46
	Ga4 5	46
	Ga4 5	46
	Ga5 5	47
	Ga1 5	43
S19202001	Ga4 5	46
	Ga4 5	46
	Ga1 5	43
S19204001	Ga1 5	43
	Ga2 5	44
	Ga2 5	44
	Ga3 5	45
	Ga3 5	45
	Ga4 5	46
	Ga4 5	46
	Ga5 5	47
	Ga5 5	47
	Ga5 5	47
	Ga1 5	43
S19212001	Ga2 5	44
	Ga3 5	45
	Ga3 5	45
	Ga5 5	47
	Ga1 5	43
S19213001	Ga2 5	44
	Ga3 5	45
	Ga5 5	47

索引 / INDEX

CODE	REF.NO	page
S19217001	Ga3 5	45
S19218001	Ga2 5	44
	Ga2 5	44
	Ga4 5	46
	Ga5 5	47
S19219001	Ga2 5	44
	Ga5 5	47
S19220001	Ga2 5	44
	Ga5 5	47
S19236001	Ga1 6	43
S19237101	Ga1 6	43
	Ga4 6	46
S19240001	Ga1 6	43
	Ga2 6	44
	Ga3 6	45
	Ga5 6	47
S19242001	Ga1 6	43
	Ga3 6	45
S19243001	Ga2 6	44
	Ga4 6	46
	Ga5 6	47
	P3 5-4	38
	P3 5-4	38
S19244101	Ga2 6	44
	Ga5 6	47
S19258001	F2 50-1-4	14
S19259001	F2 50-1-6	14
	F2 50-9-3	14
	F2 50-10-6	14
	F2 50-2-4	14
	F2 50-19-6	16
S19279001	F2 50-11-4	14
	F2 50-18-4	14
S19280001	Ga1 2	43
	Ga3 2	45
S19282001	Ga1 2	43
	Ga3 2	45
S19283001	Ga1 2	43
	Ga2 2	44
	Ga3 2	45
	Ga4 2	46
	Ga5 2	47
S19284001	Ga1 2	43
	Ga3 2	45
S19285001	Ga1 2	43
	Ga3 2	45
S19286001	Ga1 2	43
	Ga3 2	45
	Ga4 2	46
	Ga5 2	47
S19287201	Ga1 2	43
	Ga2 2	44
	Ga4 2	46
S19288201	Ga1 2	43
	Ga2 2	44
	Ga4 2	46
S19289001	Ga1 2	43
	Ga3 2	45
S19291001	Ga2 2	44
	Ga4 2	46
	P3 5-2	38
S19293001	Ga2 2	44
	Ga5 2	47

CODE	REF.NO	page
S19296001	F2 50-10-4	14
S19297001	Ga2 2	44
	Ga5 2	47
S19299001	F2 50-11-7	14
S19300001	F2 50-11-5	14
S19301001	Ga2 2	44
	Ga5 2	47
S19302001	Ga5 2	47
S19303201	Ga4 2	46
	Ga5 2	47
S19311101	F2 50-25-8	16
S19496001	F2 50-1-2	14
	F2 50-9-1	14
	F2 50-10-2	14
	F2 50-11-2	14
	F2 50-18-2	14
	F2 50-2-2	14
	F2 50-14-1	16
	F2 50-19-2	16
S19500001	Ga2 5	44
	Ga4 5	46
	Ga5 5	47
	P3 5-3	38
S19955001	Ga1 5	43
	Ga4 5	46
S19974001	Ga2 2	44
	Ga5 2	47
S19975001	Ga1 2	43
	Ga3 2	45
	Ga4 2	46
S19976001	Ga1 2	43
	Ga2 2	44
	Ga3 2	45
	Ga4 2	46
	Ga5 2	47
S19977001	Ga5 2	47
S19981001	Ga5 4	47
S19982001	Ga5 4	47
S20118151	Z1 91	40
S20130009	P3 4-6	38
S20131009	P3 4-6-1	38
S20134001	P3 4-6-1-1	38
S20135001	P3 4-6-1-2	38
S20199001	M 9	30
	M 14	30
S20310001	A 13	2
S20311000	A 14	2
S20319001	A 27-3	2
S20320101	A 27-5	2
S20321001	A 27-6	2
S20323101	D 1-5	10
S20324101	A 33	2
S20325001	A 35	2
S20327101	A 27-8	2
S20338200	A 61	4
S20339000	A 62	4
S20340001	A 69	4
S20342001	A 70	4
S20344001	A 74	4
S20345001	A 10	2
	A 75	4
S20346000	A 80	4
S20353000	B 21	6

CODE	REF.NO	page
S20355002	K 9-6	26
S20356001	B 11	6
S20361001	B 17	6
S20362151	B 18	6
S20391001	C 7-4	8
S20392000	C 7-5	8
	M 25	30
S20398001	Ga1 3	43
	Ga2 3	44
	Ga3 3	45
	Ga5 3	47
S20400001	Ga4 3	46
	Ga5 3	47
S20402001	Ga1 3	43
	Ga3 3	45
S20412000	A 48	2
	A 55	2
	Z1 67	40
S20415101	C 21	8
S20416101	C 22	8
S20424001	Ga3 9	47
	Ga4 9	47
	Ga5 9	47
S20430001	Ga4 9	46
	Ga5 9	47
S20432001	Ga3 9	45
S20434001	Ga1 9	43
	Ga2 9	44
S20436001	Ga1 9	43
	Ga2 9	44
S20438101	Ga4 9	46
S20440101	Ga4 9	46
	Ga5 9	47
S20442001	Ga1 9	43
S20453001	D 1-1	10
S20460000	D 1-1-1	10
S20476001	F1 4	12
S20485001	F1 19	12
S20494001	F1 40	12
S20495001	F1 42	12
S20526000	G 47	18
S20530001	G 30	18
S20543101	G 51	18
S20544000	G 52	18
S20547001	G 55	18
S20548001	G 59	20
S20560001	G 66	20
S20571101	H 2	22
S20574001	H 8	22
S20575001	H 9-1	22
S20576001	H 9-2	22
S20577001	H 12	22
S20578101	H 13	22
S20579101	H 15-2	22
S20582001	Ga1 8	43
	Ga2 8	44
	Ga5 8	47
S20583001	Ga1 8	43
	Ga3 8	45
S20585001	H 27	22
S20598000	K 2	26
	L 3	28
S20601001	K 5	26

CODE	REF.NO	page
S20621001	L 4	28
S20625151	L 11	28
S20627001	L 14-1	28
S20655101	M 1	30
S20657001	M 4-1	30
S20668200	M 19	30
S20669000	M 23	30
S20671000	M 22	30
S20673001	N 11	32
S20676051	N 9	32
	P1 1-1-5	34
S20677000	N 10	32
S20678001	N 14	32
S20679001	N 15	32
S20681000	N 18	32
	P1 1-1-7	34
S20682101	N 19-2	32
S20682102	N 19-4	32
S20682103	N 19-1	32
S20682104	N 19-3	32
S20682105	P1 1-1-8	34
S20684101	N 23	32
S20685001	N 25	32
S20686001	N 26	32
S20687001	N 37	32
S20689001	N 48	32
S20690001	N 49	32
S20691001	N 50	32
S20692001	N 51	32
S20718000	Z1 27	40
S20721001	Z2 64-1	42
S20722001	Z2 64-10	42
S20769000	Z1 40	40
S20878000	A 82	4
S20880001	Ga4 4	46
S20881201	Ga4 2	46
S20896101	H 15-2	22
S20897101	Ga1 7	43
	Ga2 7	44
	Ga4 7	46
	Ga5 7	47
	H 15-2	22
S20898101	Ga1 7	43
	Ga3 7	45
	H 15-2	22
S20899001	Ga1 8	43
	Ga2 8	44
S21128001	N 44	32
S21129001	N 40	32
S21130051	N 42-1	32
S21132001	N 42-2	32
S21133001	N 28	32
S21134001	N 29	32
S21135001	N 31	32
S21136101	N 35	32
S21137001	N 33	32
S21294001	P1 1-1-1	34
S21295001	P1 1-1-2	34
S21297001	P1 1-1-12	34
S21298001	P1 1-1-15	34
S21299001	P1 1-1-17	34
S21300001	P1 1-1-19	34
S21301001	P1 1-1-23	34

CODE	REF.NO	page
S21302001	P1 1-1-24	34
S21303001	P1 1-1-26	34
S21304001	P1 1-1-28	34
S21305001	P1 1-1-3	34
S21306001	P1 1-1-13	34
S21307001	P1 1-1-14	34
S21310001	P1 2-1	34
S21311001	P1 2-2	34
S21312001	P1 2-3	34
S21314001	J 1-14	24
	P1 2-7	34
S21315001	J 1-10	24
	P1 2-9	34
S21316001	J 1-12	24
	P1 2-11	34
S21318000	P3 4-3	38
S21320001	J 1-7-1	24
S21321001	J 1-7-5	24
S21322001	J 1-7-6	24
S21324001	J 1-7-8	24
S21326001	J 1-24	24
S21335001	J 1-7	24
S21336101	E 1	10
S21341001	E 1-6	10
S21373101	P2 3-1-1	36
S21375001	P2 3-1-1-2	36
	P2 3-2-1-2	36
S21376001	P2 3-1-1-9	36
	P2 3-2-1-9	36
S21377001	P2 3-1-1-11	36
	P2 3-2-1-11	36
S21378001	P2 3-1-1-12	36
	P2 3-2-1-12	36
S21379001	P2 3-1-2	36
S21380101	P2 3-2-1	36
S21381001	P2 3-2-2	36
S21392001	Ga1 5	43
	Ga3 5	45
	Ga4 5	46
S21393001	Ga1 5	43
	Ga3 5	45
	Ga4 5	46
S21394001	Ga1 5	43
	Ga3 5	45
	Ga4 5	46
S21395001	Ga1 6	43
	Ga3 6	45
	Ga4 6	46
S21590000	P1 1-4	34
S23337001	A 7	2
	A 77	4
S23342001	C 1-2	8
	C 7-1	8
	H 1-3	22
	K 9-4	26
S23346101	K 1-2	26
	L 1-2	28
	L 1-2	28
S23349001	J 1-27	24
	P1 2-13	34
S23350001	A 63	4
S23351001	A 65	4
S23353001	Z1 58	40

CODE	REF.NO	page
S23356001	Z1 10	40
S23357001	A 79	4
S23360001	G 37	18
	G 42	18
S23364000	F1 44	12
S23418002	D 1-2	10
	N 27	32
	P1 1-5	34
S23452002	N 22	32
S23614101	L 12	28
S23616101	A 25-2	2
S23621101	G 70	20
	G 76	20
	G 78	20
	H 16-1	22
S23626001	K 7	26
	L 6	28
S23628101	G 69	20
S23651002	P1 1-1-18	34
	P3 4-9	38
S23773001	E 1-2	10
S23774001	J 1-15	24
	P1 2-8	34
S23775001	P1 1-1-6	34
S23777101	P1 1-1-4	34
S23779001	P1 1-6	34
S23896101	E 1-1	10
S23897001	E 1-4	10
S24663001	Ga1 4	43
	Ga3 4	45
	Ga4 4	46
S24664001	Ga1 4	43
	Ga3 4	45
	Ga4 4	46
S24680001	Ga2 4	44
	Ga2 5	44
	Ga4 5	46
S24681001	Ga2 4	44
	Ga2 5	44
	Ga4 5	46
S25005001	P1 1-1-9	34
S25006001	P1 1-1	34
S25007001	Ga5 5	47
	J 1-5	24
S25008001	Ga5 5	47
S25009001	Ga5 5	47
S25010001	Ga5 6	47
	J 1-6	24
S25019001	P3 4-8	38
S25190001	Ga1 4	43
	Ga3 4	45
S25191001	Ga1 4	43
	Ga3 4	45
S25192001	Ga1 4	43
	Ga4 4	46
S25193001	Ga1 4	43
	Ga2 4	44
	Ga3 4	45
	Ga5 4	47
S25527001	Ga1 4	43
	Ga3 4	45
S25528001	Ga2 4	44
	Ga4 4	46

索引 / INDEX

CODE	REF.NO	page
S25529001	Ga2 4	44
	Ga4 4	46
S25538001	Ga2 2	44
	Ga5 2	47
	P3 5-2	38
S25543001	Ga1 2	43
	Ga3 2	45
S25544001	Ga1 2	43
	Ga1 2	43
	Ga3 2	45
	Ga3 2	45
S25546001	Ga2 2	44
	Ga5 2	47
S25547001	Ga2 2	44
	Ga5 2	47
S25818051	G 61	20
S27868001	B 16	6
S29700000	K 9-3	26
S29869001	Ga1 2	43
	Ga3 2	45
S29870001	F2 50-19-4	16
S29871001	Ga1 2	43
	Ga3 2	45
S29950001	Ga1 2	43
	Ga3 2	45
S29951001	Ga1 2	43
	Ga3 2	45
	Ga3 2	45
S29952001	Ga1 2	43
	Ga3 2	45
S30134001	P1 1	34
S30135101	P2 3-1	36
S30135102	P2 3-2	36
S30291001	P3 5	38
S30292001	P3 5	38
S30303001	P3 4	38
S30562000	F1 28	12
	G 18	18
S30894101	Ga2 6	44
	Ga4 6	46
S30898001	Ga4 2	46
S30900001	Ga4 2	46
S30901001	F2 50-25-3	16
S30902001	F2 50-25-4	16
S30903001	F2 50-25-5	16
S30904001	F2 50-25-6	16
S30905001	F2 50-25-7	16
S33529001	Ga5 4	47
S33530001	Ga5 5	47
S33531001	Ga5 5	47
S33536001	Ga5 6	47
S35635020	Z2 42-2-3	42
S35826021	Z2 42-2-4-2	42
	Z2 42-2-4-3	42
	Z2 42-3-1-3	42
	Z2 42-3-2-2	42
	Z2 42-4-3	42
	Z2 42-6-1-3	42
S35828021	Z2 42-2-4	42
S35831021	Z2 42-3-1-2	42
	Z2 42-6-1-2	42
S35832021	Z2 42-3-2-1	42
S35997001	Z1 29	40

CODE	REF.NO	page
S35997001	Z2 64-3	42
S36007001	Z2 64-4	42
S36062021	Z2 42-2-2	42
S36064021	Z2 42-1-2	42
S37070121	F1 34	12
S38301020	A 44	2
S38302020	Z1 65	40
S38304001	A 29	2
S38308121	F1 5	12
S38311100	G 43	18
S38312050	G 24	18
S38328051	N 1	32
S38330050	N 46	32
S39562001	A 37	2
S39564021	A 23	2
S39565101	B 24	6
S39566001	C 7	8
S39571021	C 10	8
S39574001	C 8	8
S39575001	F1 2	12
S39577000	F1 2-1	12
S39578001	G 1	18
S39585001	G 1-3	18
S39586001	G 1-4	18
S39589021	G 8	18
S39593021	G 54	18
S39596021	G 54-1	18
S39597001	M 4	30
S39598000	M 4-4	30
S39599001	M 4-3	30
S39601000	M 4-5	30
S39602000	M 4-7	30
S39603001	M 4-8	30
S39605001	A 2	2
S39606020	A 5	2
S39607001	A 8	2
S39608021	A 11	2
S39611001	A 27	2
S39612001	A 27-1	2
S39613001	A 27-2	2
S39618001	J 1-1	24
S39623001	A 38	2
S39624021	A 42	2
S39625151	A 49	2
S39626021	A 58	4
S39629021	B 3	6
S39630000	B 10	6
S39631000	B 20	6
S39644021	C 2	8
S39645021	C 3	8
S39646021	C 4	8
S39647000	C 5	8
S39648021	C 9	8
S39649021	C 15	8
S39650051	C 17	8
S39651051	J 1-2	24
S39652021	C 18	8
S39653051	C 23	8
S39658001	F1 1	12
S39659021	F1 6	12
S39660001	F1 7	12
S39661001	F1 8	12
S39662001	F1 9	12

CODE	REF.NO	page
S39663121	F1 11	12
S39664101	F1 12	12
S39665001	F1 15	12
S39666001	F1 20	12
S39667021	F1 21	12
S39669101	F1 23	12
S39670000	F1 24	12
S39671121	F1 26	12
S39672001	F1 29	12
S39673020	G 5	18
S39674001	G 9	18
S39675001	G 10	18
S39676121	G 15	18
S39677021	G 16	18
	H 5	22
	K 4	26
	L 9	28
S39678021	G 17	18
S39679001	G 20	18
S39683000	G 26	18
S39684021	G 27	1
S39685001	G 28	1
S39686000	G 44	18
S39687000	G 45	18
S39688001	G 46	18
S39690021	G 36	18
	G 41	18
S39691001	G 39	18
S39692021	G 50	18
S39693001	G 58	20
S39694021	G 64	20
S39695001	G 65	20
S39704021	H 4	22
S39706001	H 17	22
S39707001	H 19	22
S39708001	H 25	22
S39709021	H 28	22
S39728021	K 3	26
	L 8	28
S39743001	M 3	30
S39744021	M 7	30
	M 12	30
S39745001	M 8	30
S39747001	M 10	30
S39749001	M 13	30
S39751021	M 11	30
S39752021	M 15	30
S39767021	J 1-26	24
S39768001	J 1-23	24
S39769051	G 40	18
S39770001	F1 17	12
S39773001	G 35	18
S39775001	B 24	6
S39784001	A 92	4
S39795001	P1 2-6	34
S39796001	J 1-22	24
	P1 2-15	34
S39797001	J 1-16	24
S39798001	J 1-17	24
S39799001	J 1-18	24
S39800001	J 1-21	24
S40866001	L 14-2	28
S42042021	G 33	18

brother®

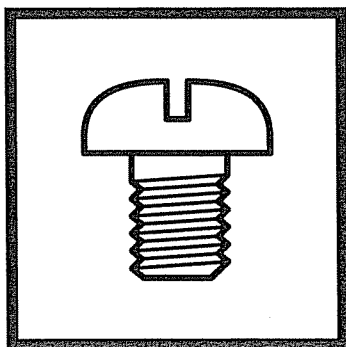

パーツブック
PARTS BOOK

ブラザー工業株式会社

〒467-8561 名古屋市瑞穂区苗代町 15 番 1 号 TEL (052) 824-2392

BROTHER INDUSTRIES, LTD

15-1, Naeshiro-cho, Mizuho-ku, Nagoya 467-8561, Japan. Phone : 81-52-824-2177

Printed in Japan

878-N21
S95N21-201
2002.02. (C)