

DH4-B980 RH-9800

Please read this manual before using the machine.
Please keep this manual within easy reach for quick reference.

ELECTRONIC EYELET BUTTON HOLER

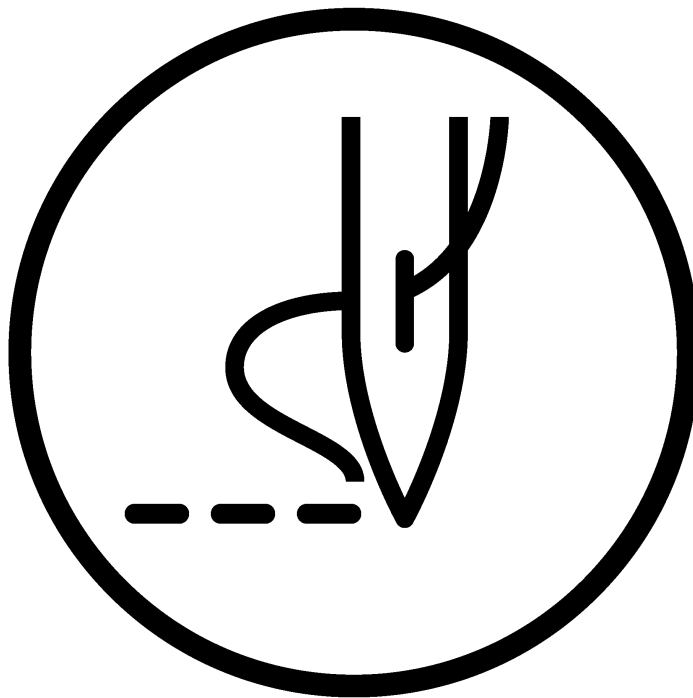

Thank you very much for buying a BROTHER sewing machine. Before using your new machine, please read the safety instructions below and the explanations given in the instruction manual.



With industrial sewing machines, it is normal to carry out work while positioned directly in front of moving parts such as the needle and thread take-up lever, and consequently there is always a danger of injury that can be caused by these parts. Follow the instructions from training personnel and instructors regarding safe and correct operation before operating the machine so that you will know how to use it correctly.

SAFETY INSTRUCTIONS







1. Safety indications and their meanings

This instruction manual and the indications and symbols that are used on the machine itself are provided in order to ensure safe operation of this machine and to prevent accidents and injury to yourself or other people. The meanings of these indications and symbols are given below.

Indications

	DANGER	The instructions which follow this term indicate situations where failure to follow the instructions will almost certainly result in death or severe injury.
	CAUTION	The instructions which follow this term indicate situations where failure to follow the instructions could cause injury when using the machine or physical damage to equipment and surroundings.

Symbols

-  This symbol () indicates something that you should be careful of. The picture inside the triangle indicates the nature of the caution that must be taken.
(For example, the symbol at left means “beware of injury”.)
-  This symbol () indicates something that you must not do.
-  This symbol () indicates something that you must do. The picture inside the circle indicates the nature of the thing that must be done.
(For example, the symbol at left means “you must make the ground connection”.)

2. Notes on safety

DANGER



Wait at least 5 minutes after turning off the power switch and disconnecting the power cord from the wall outlet before opening the face plate of the control box. Touching areas where high voltages are present can result in severe injury.

CAUTION

Environmental requirements



Use the sewing machine in an area which is free from sources of strong electrical noise such as high-frequency welders. Sources of strong electrical noise may cause problems with correct operation.



Any fluctuations in the power supply voltage should be within $\pm 10\%$ of the rated voltage for the machine. Voltage fluctuations which are greater than this may cause problems with correct operation.



The power supply capacity should be greater than the requirements for the sewing machine's electrical consumption. Insufficient power supply capacity may cause problems with correct operation.



The pneumatic delivery capability should be greater than the requirements for the sewing machine's total air consumption. Insufficient pneumatic delivery capability may cause problems with correct operation.



The ambient temperature should be within the range of 5 °C to 35 °C during use. Temperatures which are lower or higher than this may cause problems with correct operation.



The relative humidity should be within the range of 45% to 85% during use, and no dew formation should occur in any devices. Excessively dry or humid environments and dew formation may cause problems with correct operation.



Avoid exposure to direct sunlight during use. Exposure to direct sunlight may cause problems with correct operation.



In the event of an electrical storm, turn off the power and disconnect the power cord from the wall outlet. Lightning may cause problems with correct operation.

Installation



Machine installation should only be carried out by a qualified technician.



Contact your Brother dealer or a qualified electrician for any electrical work that may need to be done.



The sewing machine weighs more than 87 kg. The installation should be carried out by two or more people.



Do not connect the power cord until installation is complete, otherwise the machine may operate if the start switch is pressed by mistake, which could result in injury.



Be sure to connect the ground. If the ground connection is not secure, you run a high risk of receiving a serious electric shock, and problems with correct operation may also occur.



All cords should be secured at least 25 mm away from any moving parts. Furthermore, do not excessively bend the cords or secure them too firmly with staples, otherwise there is the danger that fire or electric shocks could occur.



Install the belt covers to the machine head and motor.



If using a work table which has casters, the casters should be secured in such a way so that they cannot move.



Be sure to wear protective goggles and gloves when handling the lubricating oil and grease, so that they do not get into your eyes or onto your skin, otherwise inflammation can result. Furthermore, do not drink the oil or eat the grease under any circumstances, as they can cause vomiting and diarrhoea. Keep the oil out of the reach of children.

CAUTION

Sewing



This sewing machine should only be used by operators who have received the necessary training in safe use beforehand.



The sewing machine should not be used for any applications other than sewing.



Be sure to wear protective goggles when using the machine.

If goggles are not worn, there is the danger that if a needle breaks, parts of the broken needle may enter your eyes and injury may result.



Turn off the power switch at the following times, otherwise the machine may operate if the start switch is pressed by mistake, which could result in injury.

- When threading the needle
- When replacing the needle
- When not using the machine and when leaving the machine unattended



If using a work table which has casters, the casters should be secured in such a way so that they cannot move.



Attach all safety devices before using the sewing machine. If the machine is used without these devices attached, injury may result.



Do not touch any of the moving parts or press any objects against the machine while sewing, as this may result in personal injury or damage to the machine.



If an error occurs in machine operation, or if abnormal noises or smells are noticed, immediately turn off the power switch. Then contact your nearest Brother dealer or a qualified technician.



If the machine develops a problem, contact your nearest Brother dealer or a qualified technician.

Cleaning



Turn off the power switch before carrying out cleaning, otherwise the machine may operate if the start switch is pressed by mistake, which could result in injury.



Be sure to wear protective goggles and gloves when handling the lubricating oil and grease, so that they do not get into your eyes or onto your skin, otherwise inflammation can result. Furthermore, do not drink the oil or eat the grease under any circumstances, as they can cause vomiting and diarrhoea. Keep the oil out of the reach of children.

Maintenance and inspection



Maintenance and inspection of the sewing machine should only be carried out by a qualified technician.



Ask your Brother dealer or a qualified electrician to carry out any maintenance and inspection of the electrical system.



Turn off the power switch and disconnect the power cord from the wall outlet at the following times, otherwise the machine may operate if the start switch is pressed by mistake, which could result in injury.

- When carrying out inspection, adjustment and maintenance
- When replacing consumable parts such as the loopers and knife



Disconnect the air hoses from the air supply and wait for the needle on the pressure gauge to drop to "0" before carrying out inspection, adjustment and repair of any parts which use the pneumatic equipment.



If the power switch and air need to be left on when carrying out some adjustment, be extremely careful to observe all safety precautions.



Use only the proper replacement parts as specified by Brother.



If any safety devices have been removed, be absolutely sure to re-install them to their original positions and check that they operate correctly before using the machine.



Any problems in machine operation which result from unauthorized modifications to the machine will not be covered by the warranty.

3. Warning labels

The following warning labels appear on the sewing machine.

Please follow the instructions on the labels at all times when using the machine. If the labels have been removed or are difficult to read, please contact your nearest Brother dealer.

1

	⚠ DANGER	⚠ GEFAHR	⚠ DANGER	⚠ PELIGRO
	Hazardous voltage will cause injury. Turn off main switch and wait 5 minutes before opening this cover.	Hochspannung verletzungsgefahr! Bitte schalten sie den hauptschalter aus und warten sie 5 minuten, bevor sie diese abdeckung öffnen.	Un voltage non adapté provoque des blessures. Eteindre l'interrupteur et attendre 5 minutes avant d'ouvrir le capot	Un voltaje inadecuado puede provocar las heridas. Apagar el interruptor principal y esperar 5 minutos antes de abrir esta cubierta.

2

	⚠ CAUTION
	Moving parts may cause injury. Operate with safety devices. Turn off main switch before threading, changing bobbin and needle, cleaning etc.

3



Do not touch the knife or press any objects against the machine while sewing, as this may result in personal injury or damage to the machine.

Safety devices
 Eye guard
 Finger guard
 Needle bar guard
 Belt cover, etc.

4



Be sure to connect the ground. If the ground connection is not secure, you run a high risk of receiving a serious electric shock, and problems with correct operation may also occur.

5



Direction of operation

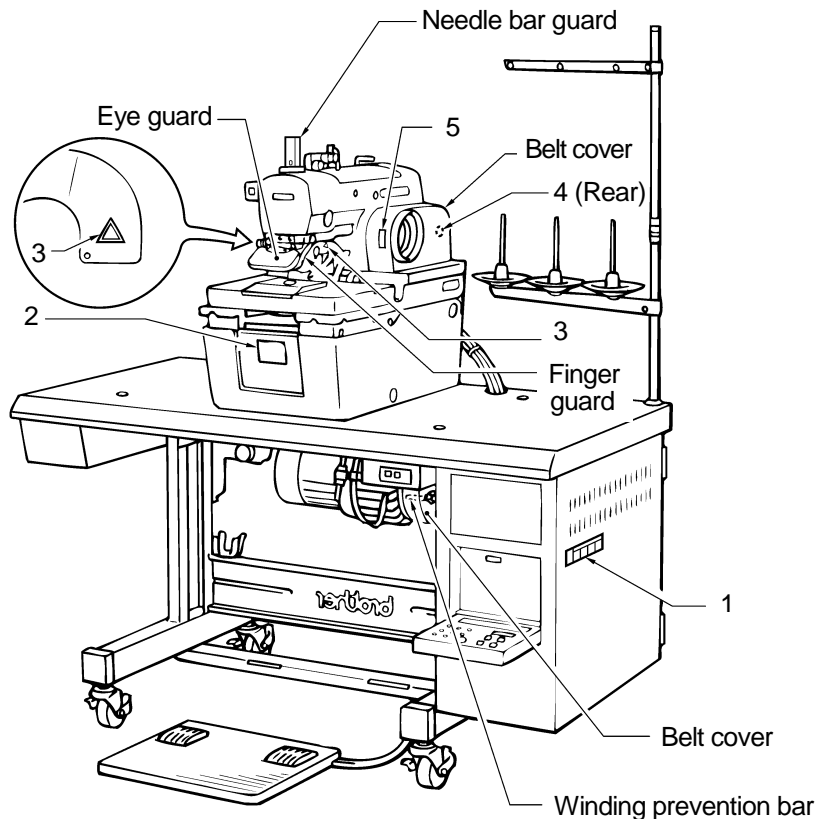

CONTENTS

1. NAMES OF EACH PART	1	7. SEWING	30
2. SPECIFICATIONS	2	7-1. Using the EMERGENCY STOP switch	30
2-1. Specifications	2	7-2. Sewing	31
3. INSTALLATION	3	7-3. Adjusting the thread tension	32
3-1. Table processing diagram	3	7-4. Needle and knife position	33
3-2. Installing the motor	4	7-5. Using the production counter	35
3-3. Installing the machine head	4	7-6. Using a cycle program	36
3-4. Installing the oil container	5	7-7. Setting the feed bracket to the front position	37
3-5. Installing the spool stand	6	7-8. Switching between single-pedal and dual-pedal operation (Switching the foot controller)	37
3-6. Tightening the V-belt	6	7-9. Using feed mode	38
3-7. Installing the control box	7	7-10. Using manual mode	39
3-8. Installing the air unit and the valve assembly	7	7-11. Changing the cycle program counter	40
3-9. Connecting the ground wires and the wirings	8	7-12. Setting the number of home position cycles	40
3-10. Connecting the air tubes	9	7-13. Returning to the home position	41
3-11. Installing the air hoses	10	8. CLEANING AND MAINTENANCE	42
3-12. Connecting the power cord	11	8-1. Cleaning	42
4. LUBRICATION	12	8-2. Draining the oil	42
4-1. Adding oil	12	8-3. Checking the air filter	42
4-2. Lubrication	12	9. STANDARD ADJUSTMENTS	43
5. CORRECT USE	14	9-1. Adjusting the height of the spreader and looper	43
5-1. Initializing settings	14	9-2. Adjusting the needle and looper timing	44
5-2. Changing the lower thread and gimp trimming	14	9-3. Adjusting the loop stroke	45
5-3. Checking the direction of machine operation	15	9-4. Adjusting the height of the needle bar	46
5-4. Installing the needle	16	9-5. Adjusting the clearance between the looper and needle	46
5-5. Threading the upper thread	16	9-6. Adjusting the needle guard	47
5-6. Threading the lower thread	17	9-7. Adjusting the spreader mounting positions	47
5-7. Threading the gimp	18	9-8. Adjusting the spreader timing	48
5-8. Setting the material	18	9-9. Adjusting the needle racking width (stitch width)	48
6. USING THE OPERATION PANEL AND FRONT PANEL	19	9-10. Changing the knife cutting length (Replacing the cutting block)	49
6-1. Panel button and switch names	19	9-11. Adjusting the contact between the knife and the cutting block	50
6-2. Selecting a program number	20	9-12. Replacing the knife	51
6-3. Changing the mode	20	9-13. Adjusting the cutting pressure	51
6-4. Changing the cutting timing	20	9-14. Adjusting the cloth opening amount	52
6-5. Setting a program	21	9-15. Adjusting the trimming of the upper thread	53
A. Setting the sewing speed	22	9-16. Adjusting the trimming of the lower thread and gimp	53
B. Setting the shape of the eyelet	22	9-17. Adjusting the gimp length after trimming (-02) ...	54
C. Setting the buttonhole length	22	9-18. Lower thread presser (-02)	55
D. Setting the tacking length	23	9-19. Sub presser (-02)	55
E. Setting the offset	23	10. SUMMARY OF DIP SWITCHES	56
F. Setting the stitch pitch	23	10-1. Front panel DIP switches	56
G. Setting the number of eyelet stitches	24	10-2. Circuit board DIP switches	57
H. Setting the cutting space	24	11. TROUBLESHOOTING	58
I. Setting the knife position compensation	24		
P1. Setting X correction	25		
P2. Setting Y correction	25		
P3. Setting θ_1 correction	25		
P4. Setting θ_2 correction	26		
6-6. Using the memory switch	27		
6-7. List of error codes	29		

1. NAMES OF EACH PART

1096Q

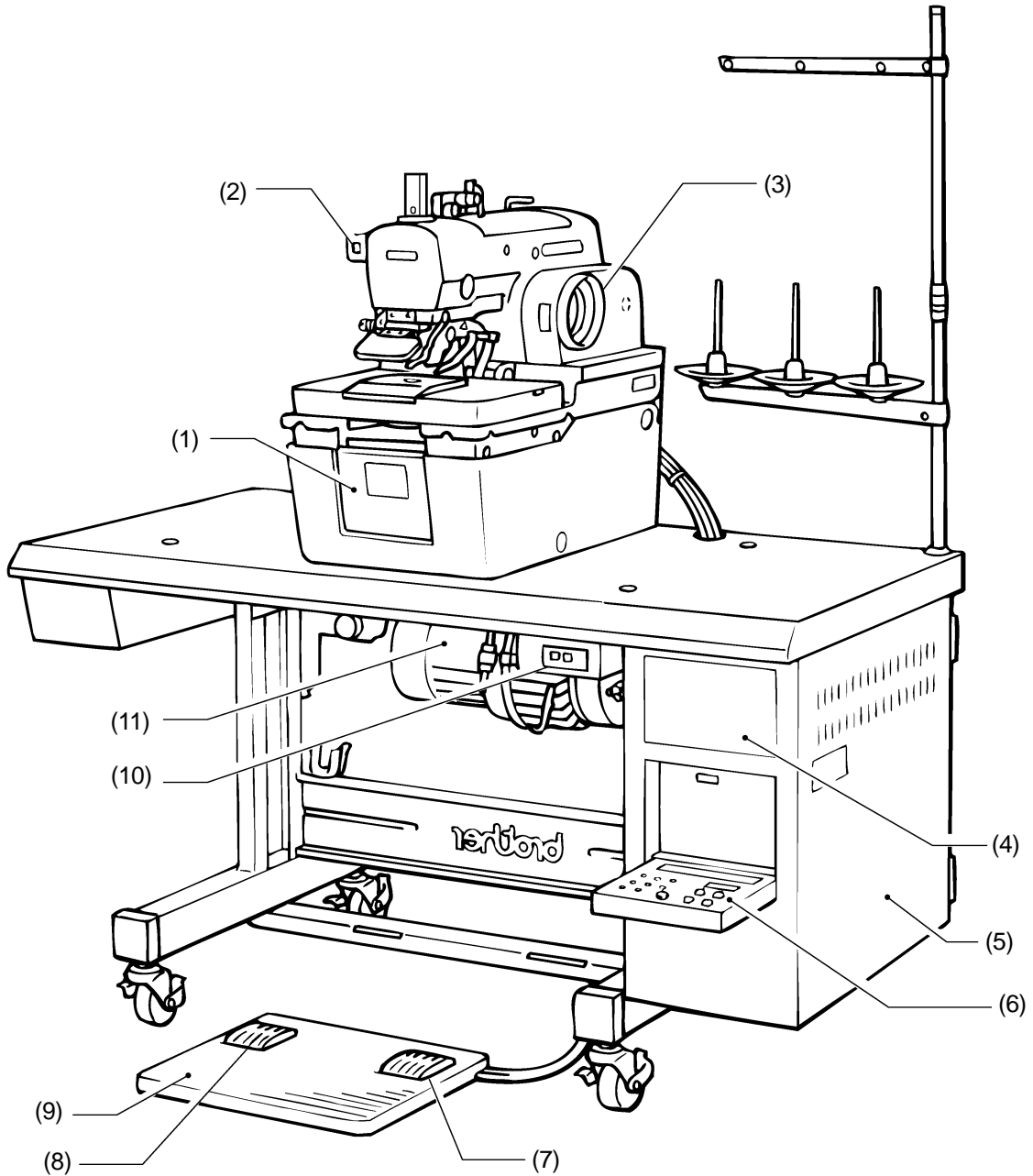

- | | | | |
|---------------------|---------------------------|------------------------|--------------------------|
| (1) Front cover | (2) EMERGENCY STOP switch | (3) Upper shaft pulley | (4) Control panel |
| (5) Control box | (6) Front panel | (7) Start switch | (8) Cloth presser switch |
| (9) Foot controller | (10) Power switch | (11) Motor | |

2. SPECIFICATIONS

2-1. Specifications

DH4-B980-

RH-9800-

	Upper thread trimmer	Lower thread trimmer	
		Long type	Short type
-00	○	-	-
-01	○	○	-
-02	○	-	○*

* -02 is further divided into L1 - L7 specifications in accordance with the stitch length. Please be sure to specify the stitch length when ordering.

Specification	-00	-01	-02
Application	Men's clothes and ladies' clothes		Jeans and work clothes
Sewing speed	1,000 - 2,000 rpm (100 rpm steps)		
Button hole length	10 - 50 mm	10 - 38 mm	L1 14 - 18 mm L5 28 - 32 mm L2 18 - 22 mm L6 32 - 36 mm L3 22 - 26 mm L7 36 - 40 mm L4 26 - 30 mm
Stitch pitch	0.5 - 2.0 mm (0.1 mm steps)		
Stitch width	1.5 - 3.2 mm		
Tacking length	3 - 43 mm (1 mm steps) or none		
Cloth presser height	12 mm		16 mm
Stitch shape changing	Selected by a program		
Cut timing selection	Selected by a switch		
Starting method	Dual switch (cloth presser switch and start switch) or single switch		
Feed method	Intermittent feed by three pulse motors (X, Y, θ)		
Needle	DO x 558 Nm 80 - Nm 120 (Schmetz)		
Safety equipment	Built-in emergency stop function and automatic stopping device which stops the machine when the safety circuit is activated		
Air pressure	Main regulator: 0.5 MPa Knife pressure regulator: 0.3 MPa		
Air consumption	43.2 l/min. (8 cycles/min.)		
Noise level	81 dB at max. speed of 2,000 rpm, measured according to ISO 10821		
Dimensions	1,200 mm (W) x 590 mm (D) x 1,120 mm (H)		
Work table legs	T-shaped height-adjustable type		
Power supply	Single-phase 110, 200, 220, 230, 240 V 3-phase 220, 380, 415 V Maximum electric power consumption: 1 kVA		
Weight	175 kg		

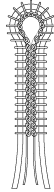
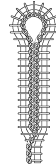
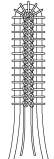
Sewing shape	Eyelet buttonhole		Straight buttonhole				
	0793Q		0794Q		0795Q		0796Q
	Eyelet buttonhole	Eyelet buttonhole with taper	Straight buttonhole	Straight buttonhole with taper			

3. INSTALLATION

⚠ CAUTION

- ⊘
 Machine installation should only be carried out by a qualified technician.
- !
 Contact your Brother dealer or a qualified electrician for any electrical work that may need to be done.
- !
 The sewing machine weighs more than 87 kg. The installation should be carried out by two or more people.
- ⊘
 Do not connect the power cord until installation is complete, otherwise the machine may operate if the start switch is pressed by mistake, which could result in injury.
- !
 All cords should be secured at least 25 mm away from any moving parts. Furthermore, do not excessively bend the cords or secure them too firmly staples, otherwise there is the danger that fire or electric shocks could occur.
- ⚡
 Be sure to connect the ground. If the ground connection is not secure, you run a high risk of receiving a serious electric shock, and problems with correct operation may also occur.
- !
 Install the belt covers to the machine head and motor.

3-1. Table processing diagram

Use the special table indicated below.

Thread trimmer	Product code
Upper thread trimmer	127-980-000-01
Upper and lower thread trimmer	127-980-001-01

If using a commercially-available table, process it as shown in the illustration below.

Note: The thickness of the table should be at least 50 mm, and it should be strong enough to bear the weight and vibration of the sewing machine.

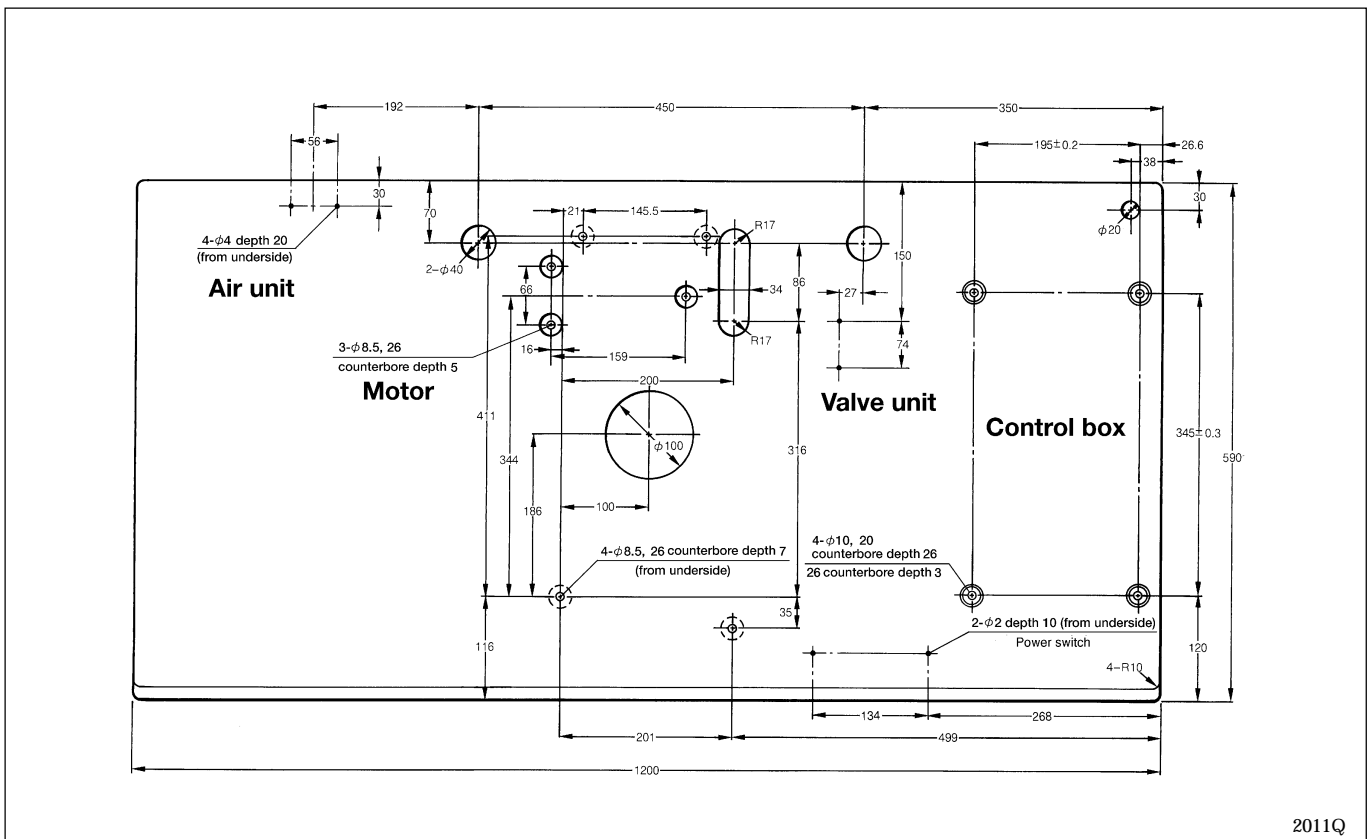

2011Q

3-2. Installing the motor

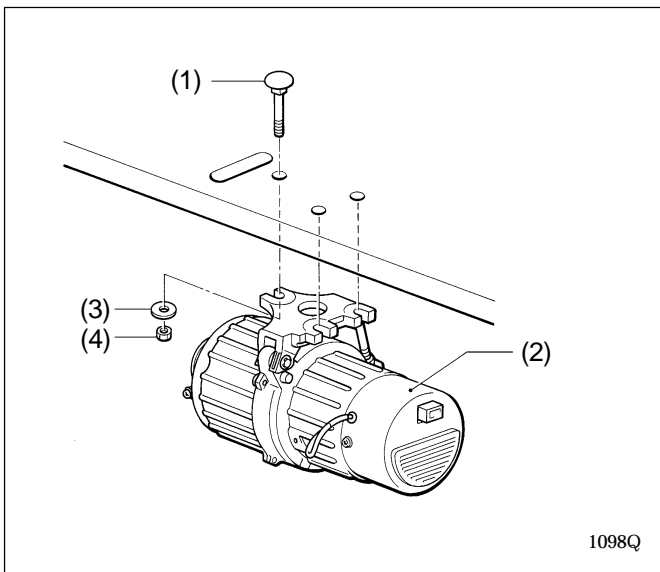

1. Insert the three bolts (1) into the work table.
 2. Turn the work table upside down to make it easier to install the motor (2).
 3. Align the motor (2) with the bolts (1), and then install the motor (2) to the underside of the work table with the three washers (3) and the three nuts (4).
- Note: Do not use the cushion rubber. If you use it, V belt tension cannot be adjusted.

3-3. Installing the machine head

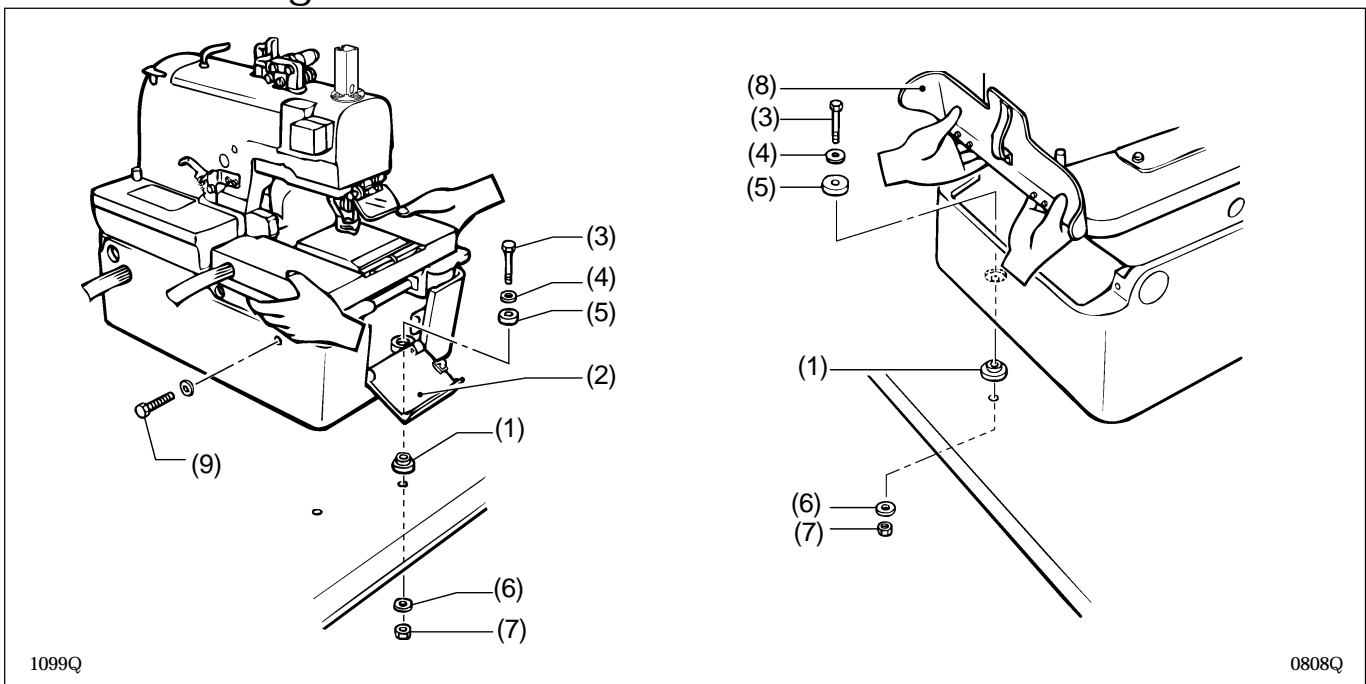

1. Insert the accessory bed stand cushions A (1) into the bed stand, and then place the machine head on top of the work table.
 Note: When placing the machine head on top of the work table, have two or more people there to hold the handles A and B and the rear of the head C.
2. Open the front cover (2), and then use the bed stand mounting bolt (3), washer (4), cushioning rubber (5), bed stand cushion A (1), large washer (6) and nut (7) to attach the front right corner of the bed stand to the work table.
3. Open the rear cover (8), and then attach the bed stand to the work table in two places inside the stand in the same way as in step 2. above.
4. Remove the fixing bolt (9) and the washer.
 Note: The fixing bolt (9) and washer should be kept, as they will be needed again if the machine head is moved.
5. Raise the machine head, and then attach the front left corner of the bed stand to the work table in the same way as in the steps above.
 Note: Make sure that steps 2. to 4. above have been completed before raising the machine head.

Raising the machine head

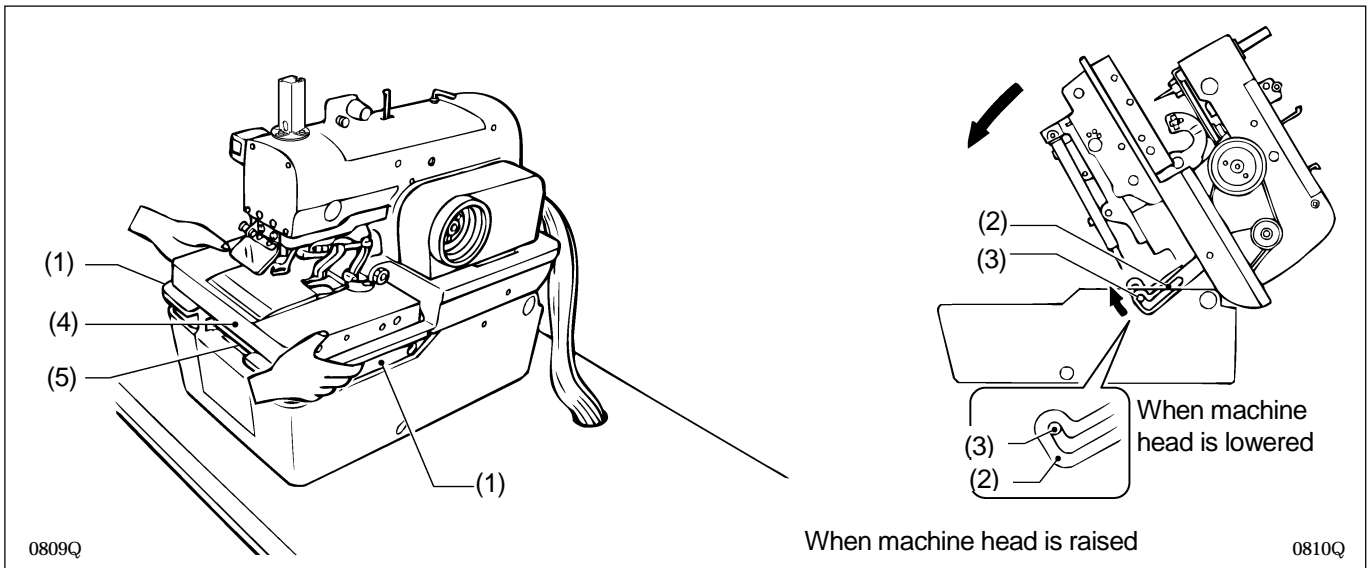

1. While holding the handles of the machine head (1) with both hands, gently raise the machine head.
Note: Be sure to turn the power supply off before raising the machine head.
2. If you wish to keep the machine head in the raised position, insert the head support lever (2) securely into the hinge lever support shaft (3).
Note: Always check that the head support lever (2) and the hinge lever support shaft (3) are meshed.

Lowering the machine head

Pull the machine head down toward you gently, remove the head support lever (2) from the hinge lever support shaft (3), and then gently lower the machine head.

Note: Do not hold the machine head by the feed bracket (4) or X feed shaft A (5) when it is being raised and lowered.

3-4. Installing the oil container

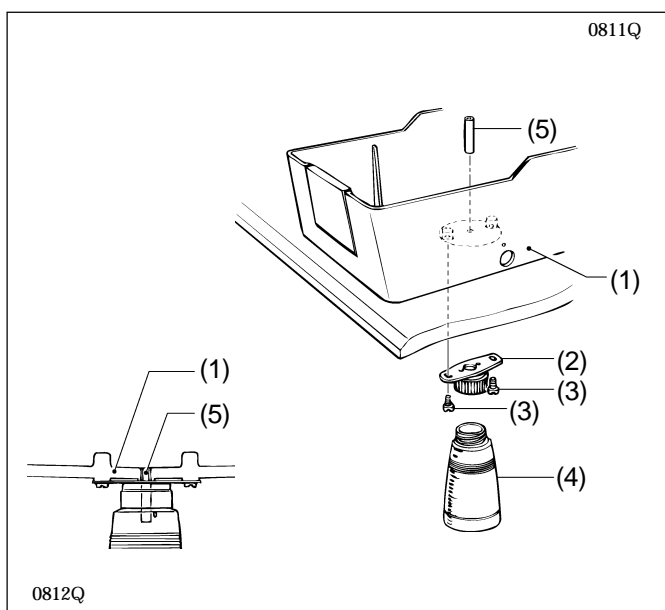

1. Install the oil draining cap support (2) to the base of the bed stand (1) with the two screws (3).
2. Screw the oil container (4) into the oil draining cap support (2).
3. Push the oil draining spring pin (5) into the bed stand (1) until the pin is flush with the surface of the stand.
4. Lower the machine head. (Refer to "Lowering the machine head" above.)

3-5. Installing the spool stand

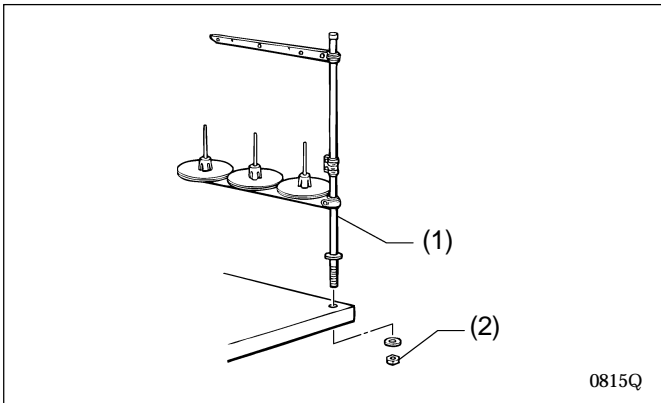

1. To assemble the spool stand (1), follow the instructions in the manual that came with the spool stand (1).
2. Secure the spool stand (1) to the rear right corner of the work table with the washer and nut (2).

3-6. Tightening the V-belt

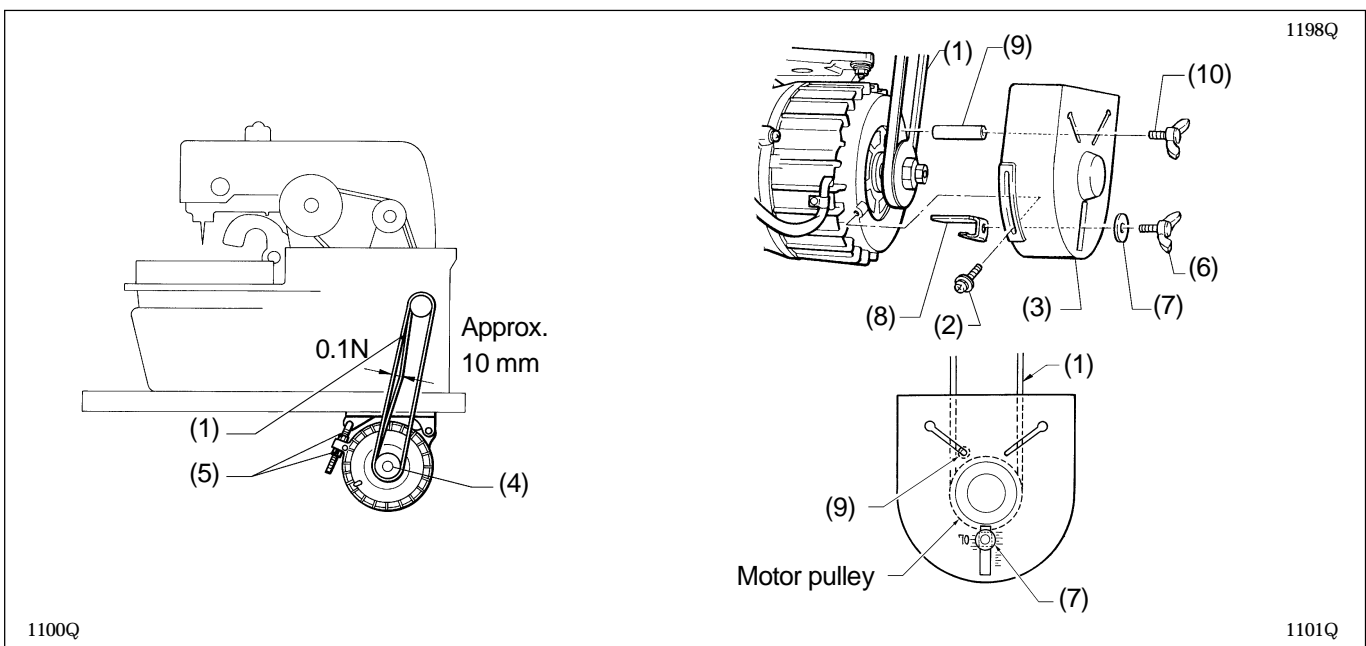

1. Open the rear cover.
2. Pass the V-belt (1) through the base of the bed stand and through the hole in the work table.
3. Loosen the two screws (2) and then remove the motor pulley cover (3).
4. Place the V-belt (1) onto the motor pulley (4).
5. Check that there is approximately 10 mm of deflection in the V-belt (1) when it is pushed in the middle with a load of 0.1 N.
If the tightness needs adjusting, loosen the two nuts (5) and move the motor up or down.
6. Install the belt casting prevention bracket (8) to the pulley cover (3) with the wing bolt (6) and washer (7).
Align the center of the washer (7) with the gradation (7) 0 shown on the outside of the pulley at this time.
7. Provisionally tighten the winding prevention bar (9) to the pulley cover (3) with the wing bolt (10).
8. Install the pulley cover (3) and tighten it with the two screws (2).
Note: Check that the V-belt is not touching the belt casting prevention bracket (8).
9. Align the winding prevention bar (9) with the point in between the V-belt and the motor pulley, and then secure it by tightening the wing bolt (10).
Note:
 - Check that the winding prevention bar (9) does not touching the V-belt or the motor pulley.
 - After a long period of use, the V-belt will become run in and will loosen around the motor pulley. When this happens, turn off the power and adjust by the procedure given in step 5. above.

3-7. Installing the control box

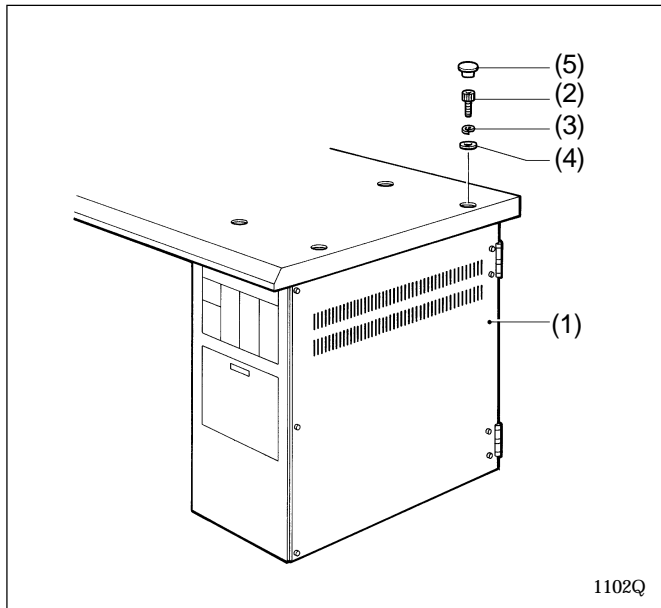

1. Align the four bolt holes in the control box (1) with the four holes in the work table.
2. Install the control box (1) with the four bolts (2), spring washers (3) and flat washers (4)
3. Push the four caps (5) in over the top of the bolts (2).

3-8. Installing the air unit and the valve assembly

Refer to the work table processing diagram on page 3 for the installation position.

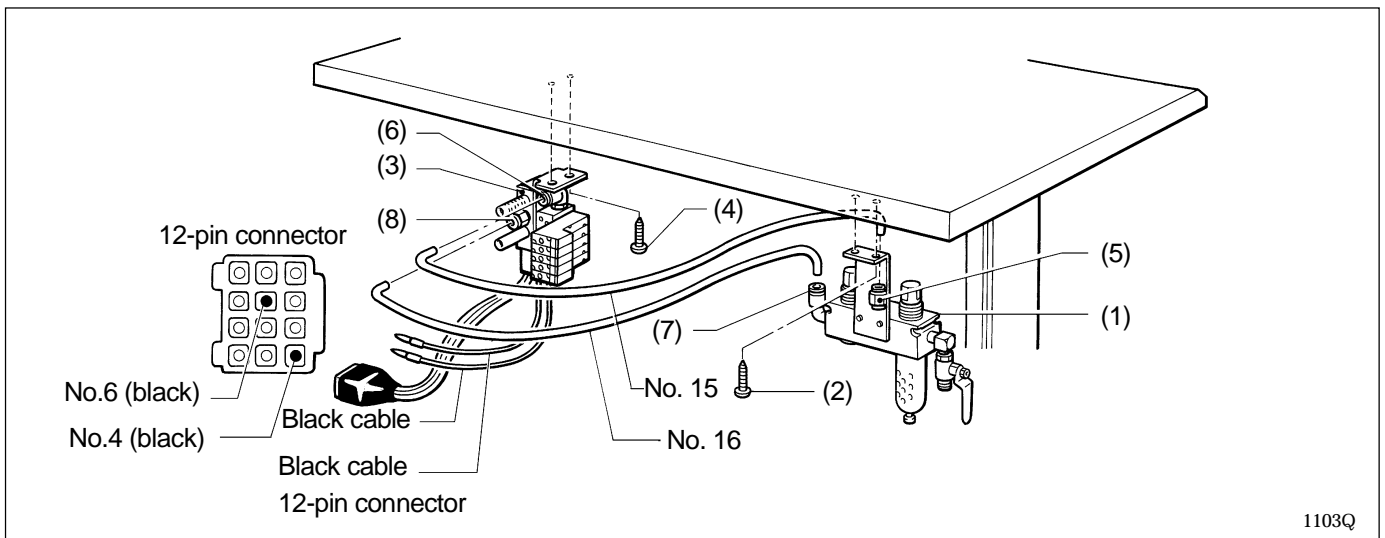

1. Install the air unit (1) to the underside of the work table with the two screws (2).
2. Install the valve assembly (3) with the two screws (4).
3. Connect air hose No. 15 to the intermediate joint (5) of the air unit (1) and to the joint (6) of the valve assembly (3), and connect air hose No. 16 to joints (7) and (8).

Connecting the knife valve cables

Connect the two black knife valve cables to terminal No.4 and No.6 of the 12-pin connector of the air harness.

3-9. Connecting the ground wires and the wirings

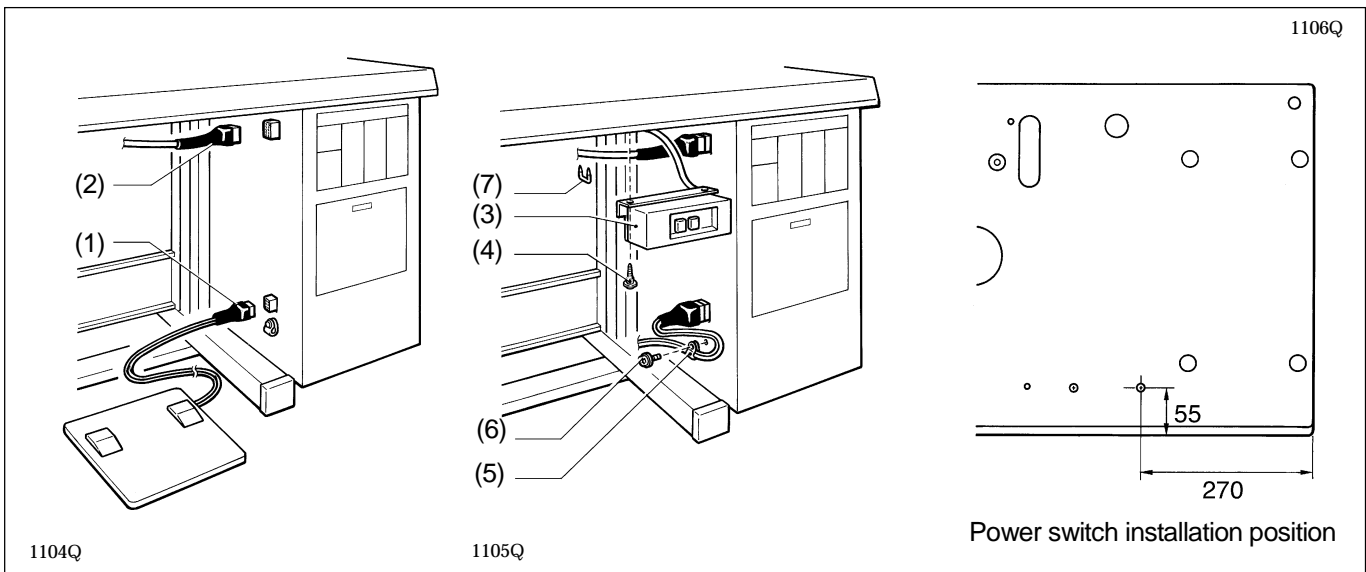

1. Connect the foot controller cable (1) and the motor cable (2) to the control box.
2. Install the power switch (3) to the underside of the work table with the two screws (4).
3. Clamp the foot controller cable (1) with the two cable clips (5) and then secure the cable clips (5) with the screws (6).
4. Install the motor cable (2) and the power switch cable to the underside of the work table with the staple (7).

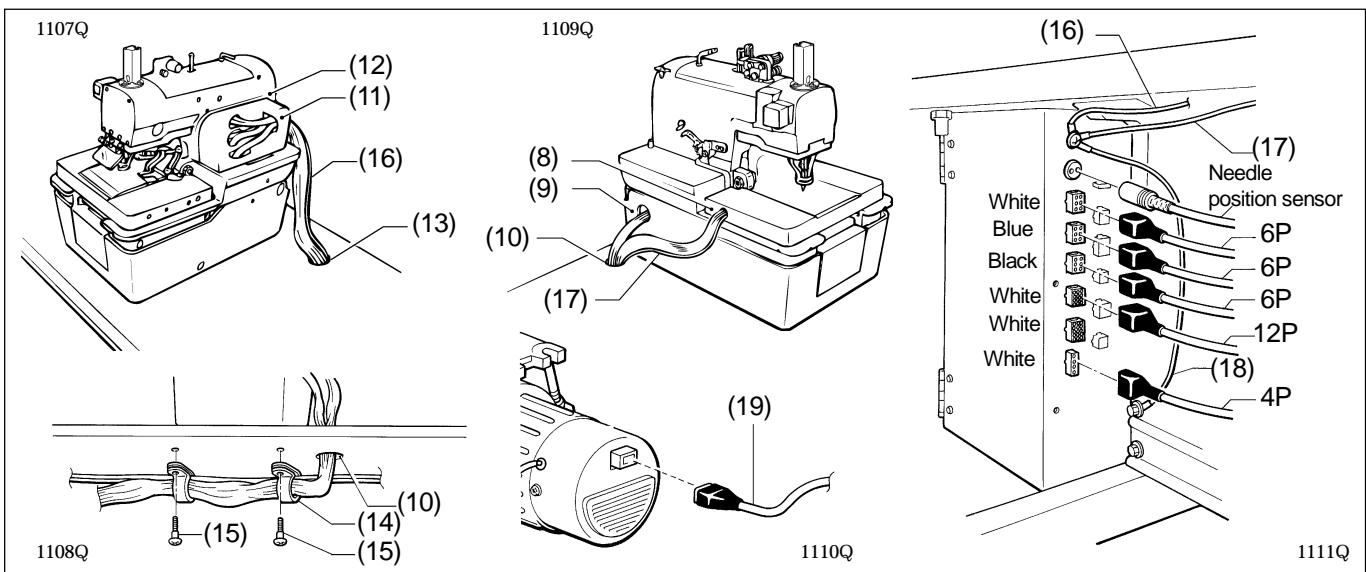

5. Pass the cable and air tube which are coming out of the feed bracket (8) and the left side of the bed stand (9) through the cable hole (10) in the work table.
6. Pass the cable and air tube which are coming out of the belt cover (11) and the machine head (12) through the cable hole (13) in the work table.
7. Insert each of the connectors into the connectors on the control box. (Refer to the illustration above.)
8. Pass the cables and air hoses through the two cable holders (14), and then secure the cable holders (14) to the underside of the work table with the two screws (15).
9. The ground wires (16), (17) should always be connected to the control box.
10. Connect the accessory ground wire (18) to the ground terminal of the control box and to the table leg installation bolt.
Note: If the ground wire is not connected, mis-operation due to discharges of static electricity may occur.
11. Connect the power switch connector (19) to the motor.

< -02 >

Specification	Label No. of harness	Right/left cloth presser No. Right/left movable knife No. Thread handler No.
L1	1	1
L2	2	2
L3	3	3
L4	4	4
L5	5	5
L6	6	6
L7	7	7

1112Q 1113Q

- Insert the harness (L1 - L7) (1) to connector No. 10 (9-pin).
 - * When connecting the harness (1), check that its label number is the same as the numbers on the right movable knife (2), left movable knife (3), thread handler (4), right cloth presser (5), left cloth presser (6) and movable knife driving cam (7). (If a connector with a different label number is inserted, the machine could be damaged or thread trimming errors could result.)
 - * There is 10 mm of difference in the knife installation positions between L1 - L4 and L5 - L7.

3-10. Connecting the air tubes

Connect the air tubes to the joints of the solenoid valve assembly, using the illustration below as a reference. Numbers are marked on each of the air hoses which come out of the sewing machine.

< -00,-01 >

Label No.	Solenoid valve
5	Upper thread trimming
4	Upper thread tightening
3	Lower thread trimming *1
2	Cloth spreading (Sub presser *2)
1	Cloth presser

*1 If the lower thread trimmer is not installed, solenoid valve [3] is not used.
*2 The sub presser can only be used for machines with -02 specification.

0826Q 0827Q

< -02 >

0828Q 0829Q

3-11. Installing the air hoses

Connect the air hose from the compressor to the air unit underneath the work table.

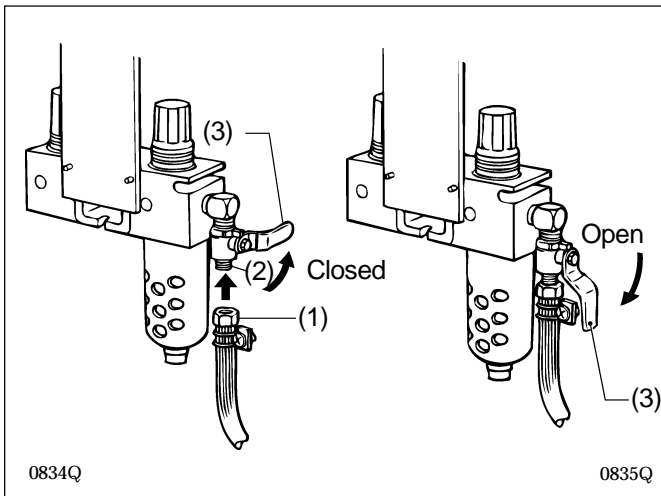

1. Turn the nut (1) at the end of the air hose, and then connect the hose to the valve (2).
2. Open the air cock (3) on the compressor. Check that there is no air leaking from the valve connection.
3. Open the cock (3) by turning it in the direction of the arrow. The meter needle will move clockwise.
4. Adjust the air pressure by following the procedure on the next page.

Adjusting the air pressure

Set the air pressure for the knife pressure adjustment regulator (3) to the lowest pressure at which the knife can still cut the material. Set the standard air pressure for the main regulator (1) to 0.5 MPa.

To increase the air pressure

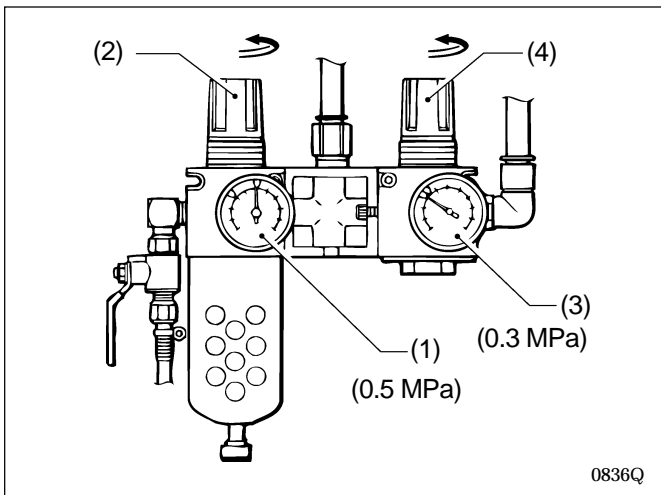

1. Gently lift the knob (2) of the main regulator (1) and turn it in the direction of the arrow in the illustration. The pressure will increase when the knob (2) is turned clockwise.
2. Gently lift the knob (4) of the knife pressure adjustment regulator (3) and turn it in the direction of the arrow in the illustration. The pressure will increase when the knob (4) is turned clockwise.

* The pressure for the knife pressure adjustment regulator (3) is adjusted to 0.3 MPa. Be careful not to increase this pressure needlessly, otherwise poor cutting performance or damage to the knife may result.

To decrease the air pressure

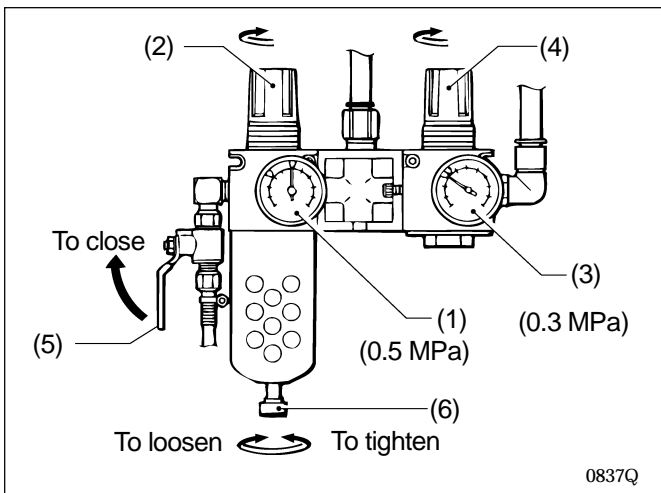

1. Close the cock (5). (The needle will remain at the high pressure position.)
2. Turn the knob screw (6) in the direction of the arrow in the illustration to loosen it. Make sure that you turn it in the correct direction. The air will escape from the reservoir and the needle will drop.
3. Tighten the knob screw (6).
4. To reduce the air pressure, gently lift knob (2) or knob (4) and turn it counterclockwise.
5. Open the cock (5). Air will enter the reservoir and the needle will move

3-12. Connecting the power cord

 CAUTION



Contact your Brother dealer or a qualified electrician for any electrical work that may need to be done.



Be sure to connect the ground. If the ground connection is not secure, you run a high risk of receiving a serious electric shock, and problems with correct operation may also occur.

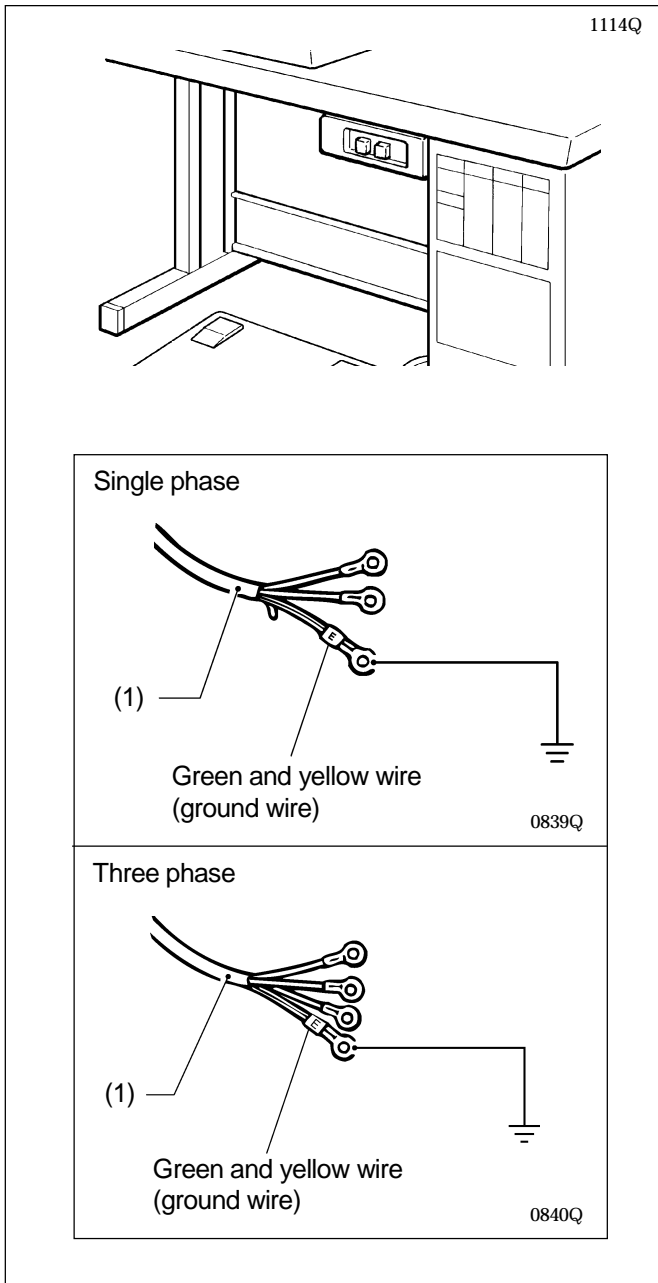

Do not connect the power cord until installation is complete, otherwise the machine may operate if the start switch is pressed by mistake, which could result in injury.



1. Attach an appropriate plug to the power cord (1). (The green and yellow wire is the ground wire.)
2. Insert the plug into properly-grounded AC power supply.

Note: Do not use extension cords, otherwise machine operation problems may result.

4. LUBRICATION

⚠ CAUTION



Turn off the power switch before starting lubricating, otherwise the machine may operate if the start switch is pressed by mistake, which could result in injury.



Be sure to wear protective goggles and gloves when handling the lubricating oil and grease, so that they do not get into your eyes or onto your skin, otherwise inflammation can result.

Furthermore, do not drink the oil or eat the grease under any circumstances, as they can cause vomiting and diarrhoea.

Keep the oil out of the reach of children.

Use only specified Brother oil (Nisseki Mitsubishi Sewing Lube 10 N; VG10) for the machine oil.

4-1. Adding oil

Check the oil level by looking at the sight glass. If the oil level is low, replenish the oil supply.

Filling the arm oil tank

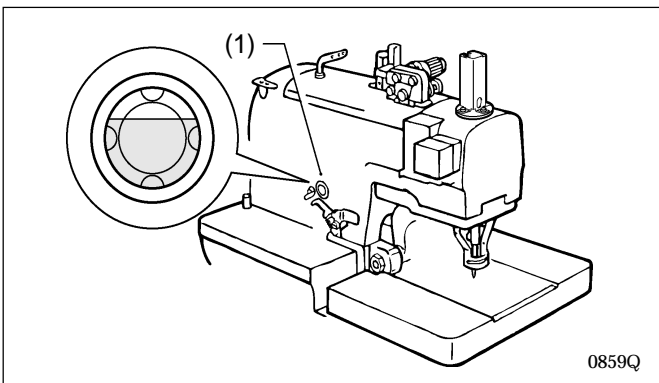

1. Pour approximately 10 cc of machine oil into the arm oil tank (1) (until it is about four-fifths full).

Filling the bed base oil tank

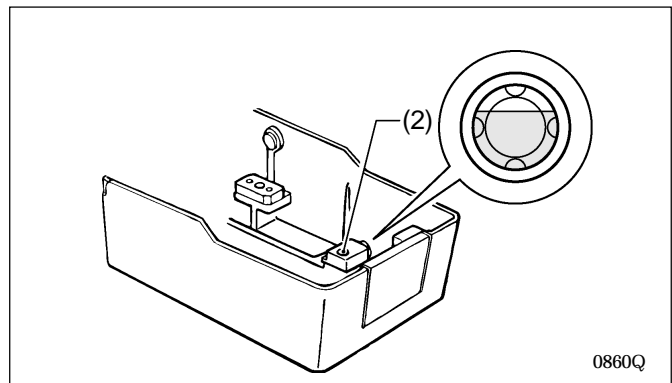

1. Raise the machine head.
2. Pour approximately 20 cc of machine oil into the bed base oil tank (2) (until it is about four-fifths full).
3. Lower the machine head.

4-2. Lubrication

Oil these parts once a day.

Oil the moving parts of the needle bar, looper and spreader mechanisms and also the cam groove, roller, the felt at the base of the wick and the wick before using the sewing machine for the first time, and also after long periods of non-use.

When oiling, some oil will get onto the thread. Carry out a test sewing to ensure that your material does not get stained with oil.

Oiling the needle bar and cam

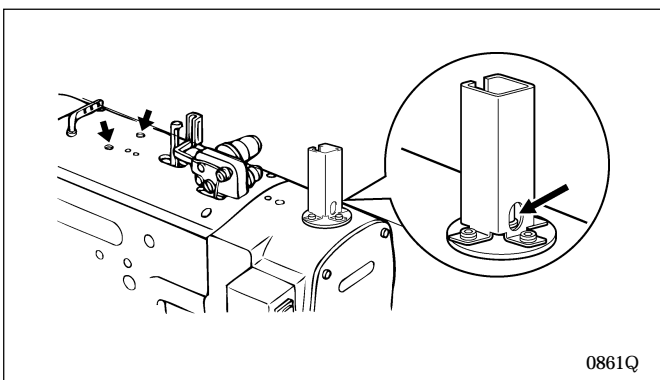

Add 2-3 drops of oil in the places indicated by the arrows.

Oiling the looper, spreader and race stand

<Removing the cloth presser plates>

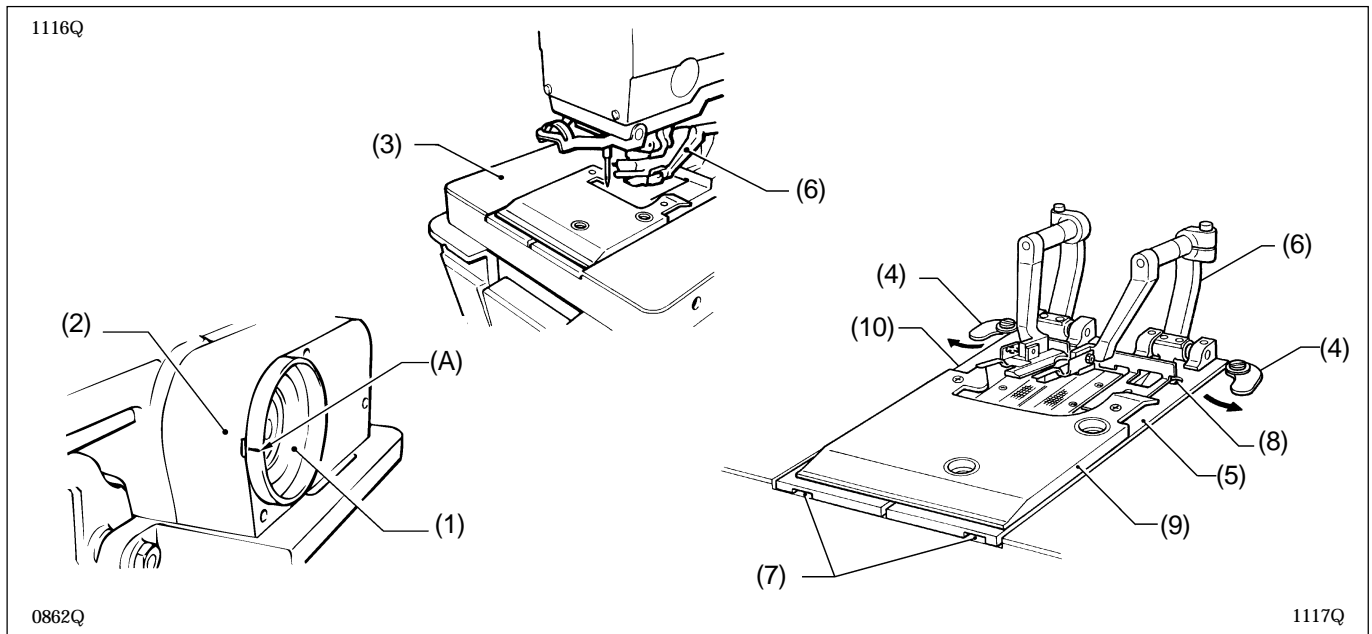

1. Turn the upper shaft pulley (1) toward you until the mark on the pulley (A) is aligned with the notch in the pulley cover (2).
2. Move the feed bracket (3) toward you.
3. Turn the left and right plate pressers (4) in the directions indicated by the arrows.
4. Lift up the clamp lever (6) and the notched section (7) of the right cloth presser plate (5), remove the right cloth presser plate (5) from the pin (8), and then pull the right cloth presser plate (5) toward you to remove it.
 Note: If the lower thread trimmer has been installed, move cloth presser plate U (9) to a position where it can be removed without its touching the needle.
 Raise cloth presser plate U (9), pass the needle through the hole, and then remove cloth presser plate U (9) from the pin (8).
5. Remove the left cloth presser plate (10) in the same way as the right cloth presser plate (5) was removed.

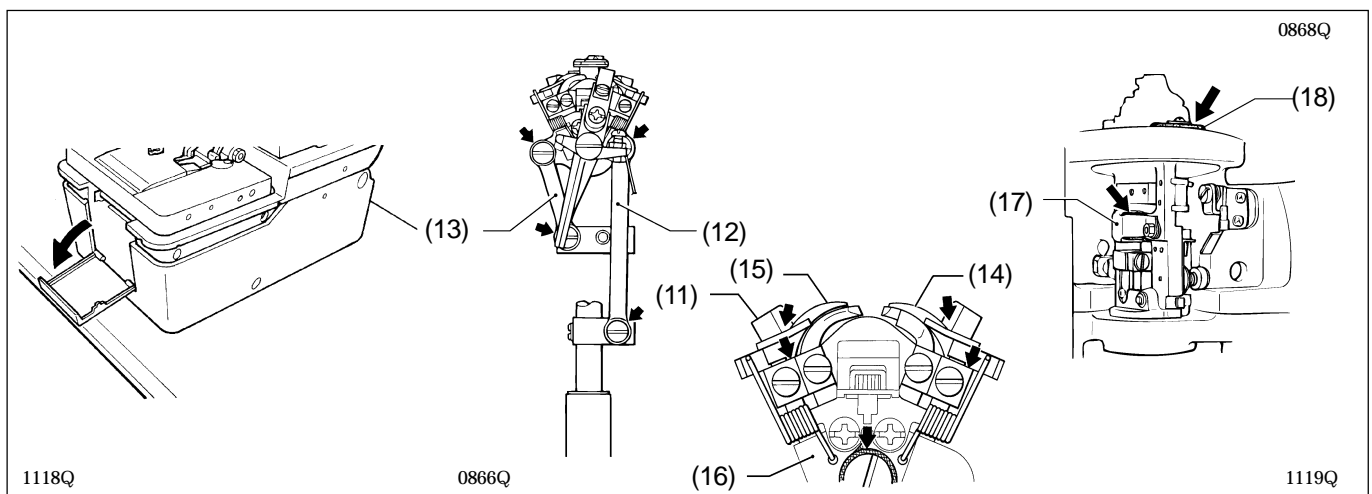

6. Open the front cover.
7. Turn the race stand and add a few drops of oil to the spreader cam (11), and to the supports for the looper link (12) and spreader link (13).
8. Add a few drops of oil to the shafts of the right spreader (14), left spreader (15) and LS-holder bracket (16).
9. Fill the felt tank (17) on the race stand with oil also.
10. Add 5 - 6 drops of oil to the felt (18) which is attached to the sliding surfaces of the race stand and the bed.
11. Close the front cover.
12. Install the cloth presser plates by carrying out the steps 5., 4. and 3. in that order.

5. CORRECT USE

5-1. Initializing settings

The following procedure should be carried out before the sewing machine is used for the first time, and also after long periods of non-use.

If "E-59" appears on the front panel display when the power is turned on, be sure to follow this procedure to initialize all settings. ("E-59" will appear after a PROM has been replaced or after long periods of non-use. For details on the "E-59" message display, refer to page 27.)

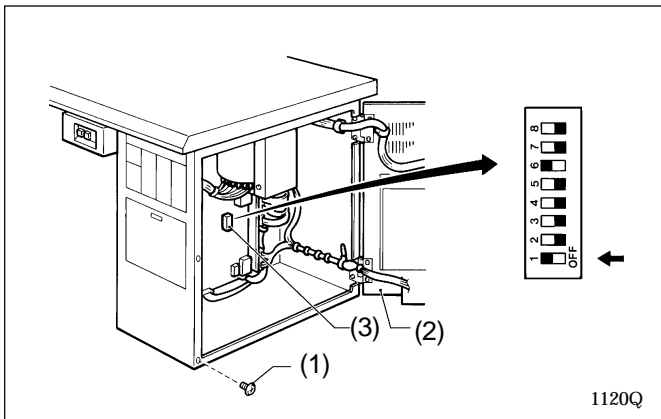

1. Turn off the power.
2. Remove the five screws (1).
3. Open the rear plate (2) of the control box.
4. Set DIP switch No. 1 (3) on the circuit board to ON.
5. Turn the power back on again.
Note: A buzzer will sound while the data is being initialized.
6. Turn off the power.
7. Set DIP switch No. 1 (3) on the circuit board to OFF.
8. Close the rear plate (2) and tighten the five screws (1).

5-2. Changing the lower thread and gimp trimming

The sewing machine is set to lower thread and gimp trimming when it is shipped from the factory. (DIP switch No. 6 (3) is set to ON.)

Carry out the following procedure only if you wish to activate upper thread trimming.

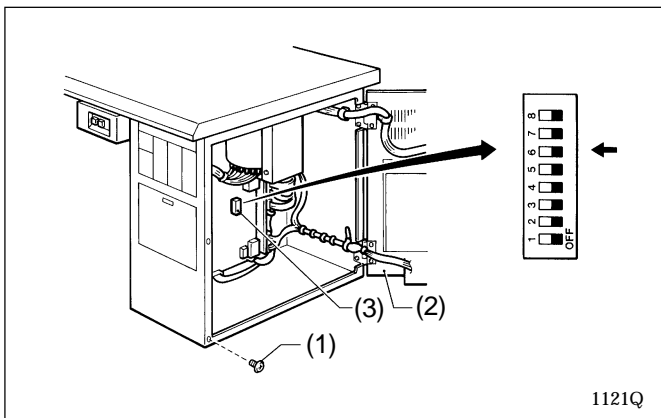

1. Turn off the power.
2. Remove the five screws (1).
3. Open the rear plate (2) of the control box.
4. Set DIP switch No. 6 (3) on the circuit board to OFF.
Note: Do not activate lower thread trimming if using a 39-mm cutter.
Do not set DIP switch No. 6 (3) on the circuit board to ON.
5. Close the rear plate (2) and tighten the five screws (1).

5-3. Checking the direction of machine operation

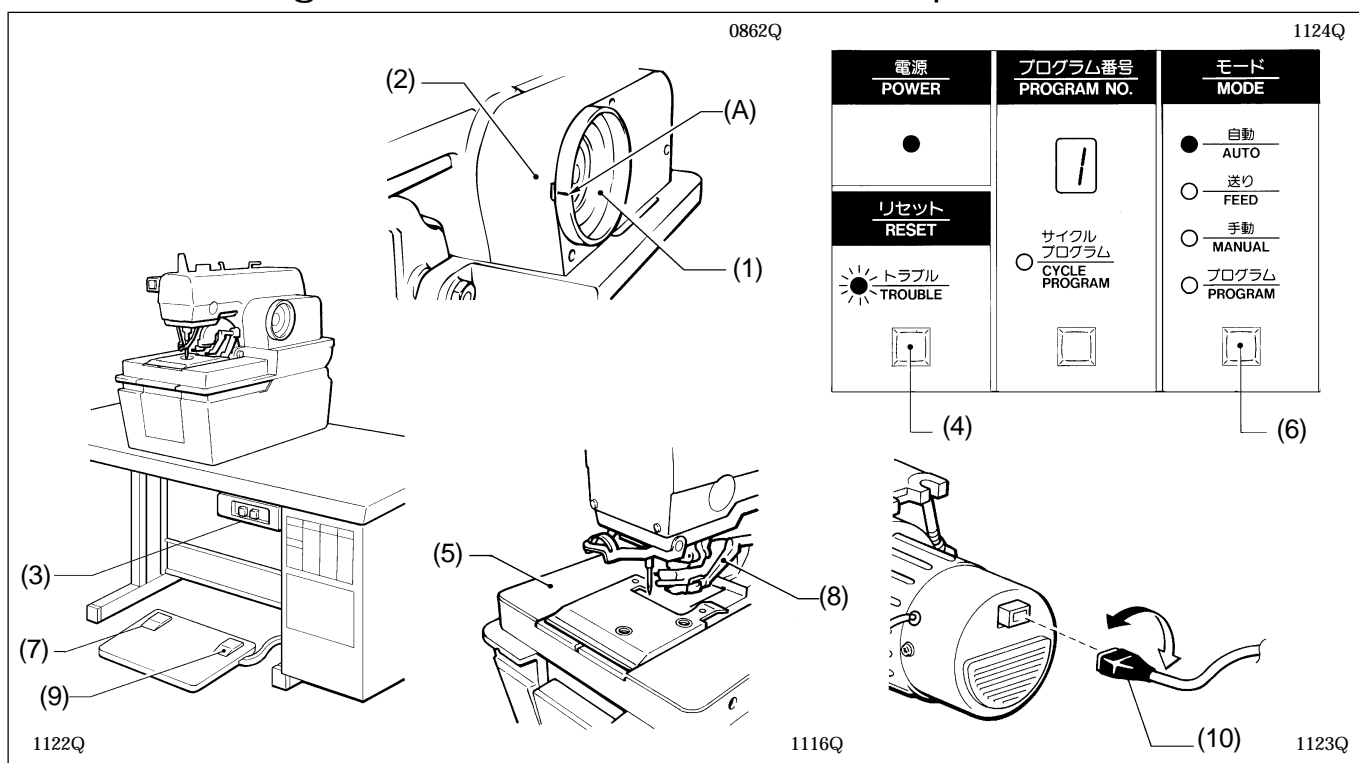

1. Turn the upper shaft pulley (1) toward you until the mark (A) on the pulley (1) is aligned with the notch in the cover (2).
2. Press the power switch (3) to turn on the power.
The power indicator will illuminate and the TROUBLE indicator will flash.
3. Press the RESET button (4).
The TROUBLE indicator will switch off and the feed bracket (5) will move to the cloth setting position.
4. Press the MODE button (6) to switch to automatic mode.
The AUTO mode indicator will illuminate.
5. Depress the cloth presser switch (7).
The cloth presser (8) will be lowered.
6. Depress the start switch (9).
The machine will sew one buttonhole and will then stop.
* If the buzzer makes a beeping sound and "E-89" appears on the front panel display, the direction of operation of the upper shaft is reversed.
Press the power switch (3) to turn the power off, and then switch over the top and bottom motor connectors (10).
7. The direction of machine operation will now be correct.

5-4. Installing the needle

CAUTION



Turn off the power switch before installing the needle, otherwise the machine may operate if the start switch is pressed by mistake, which could result in injury.

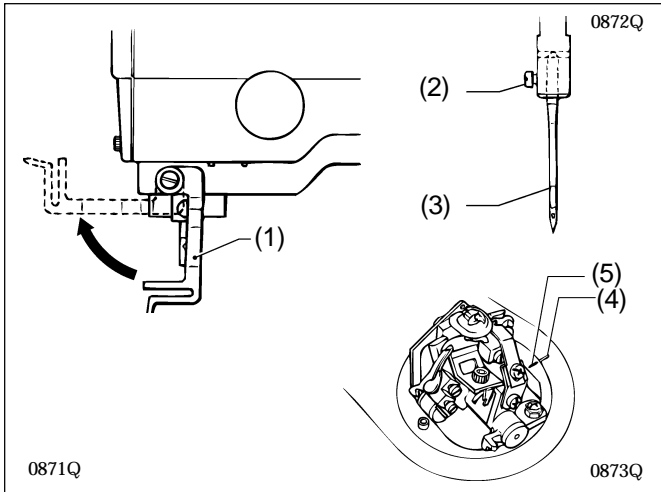

Use only Schmetz D0 x 558 Nm80 – Nm120 needles.

1. Raise the finger guard (1).
2. Loosen the screw (2), and then remove the needle (3).
3. Insert the new needle (3) as far as it will go so that the groove is facing toward you.
4. Securely tighten the screw (2).
5. Remove the cloth presser plates. (Refer to page 13.)
Note: After removing the cloth presser plates, check that the index mark (4) on the machine head is aligned with the index mark (5) on the race stand before inserting the needle (3) (when the race stand is turned fully to the right).
6. Lower the finger guard (1).

5-5. Threading the upper thread

CAUTION



Turn off the power switch before threading the thread, otherwise the machine may operate if the start switch is pressed by mistake, which could result in injury.

Thread the upper thread as shown in the illustration below.

* Use the accessory needle threader (1).

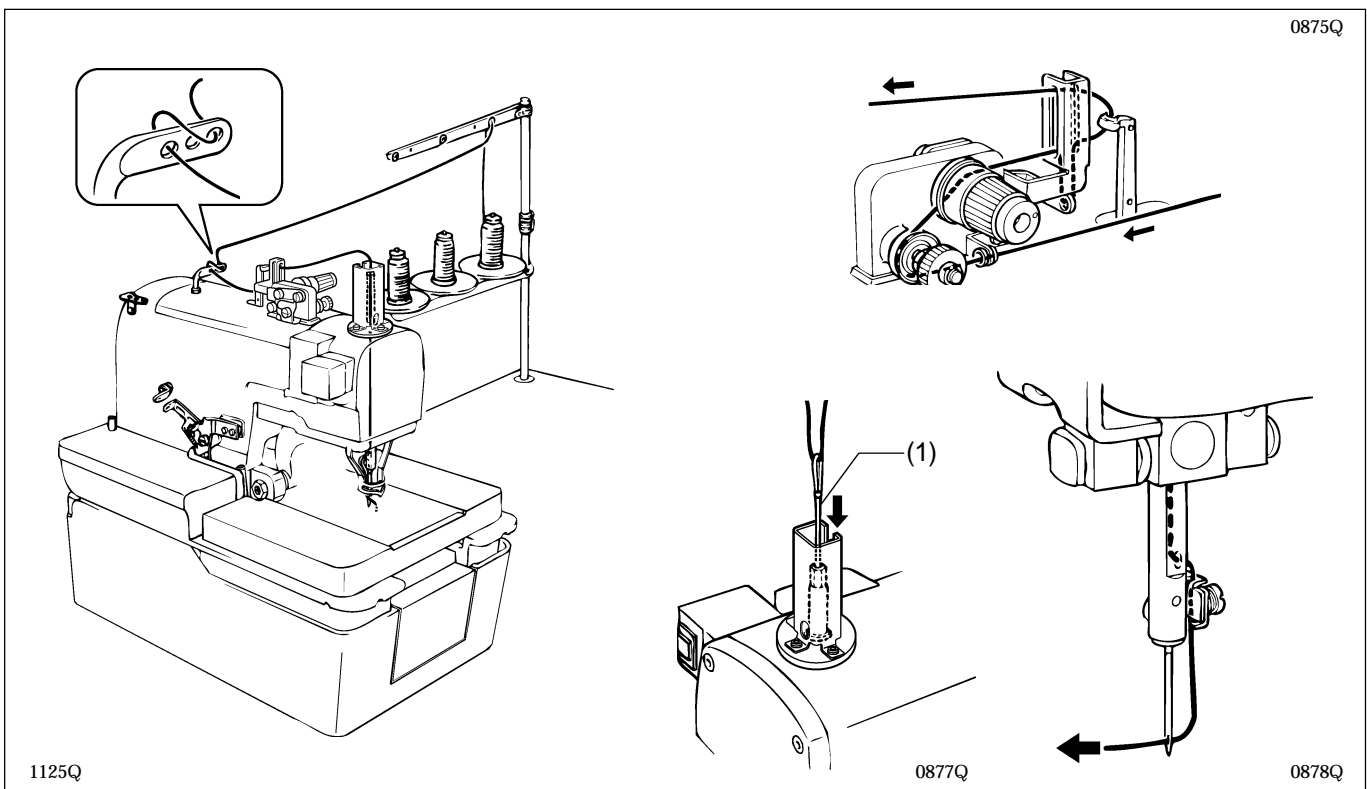

5-6. Threading the lower thread

Remove the cloth presser plates (refer to page 13), and then thread the lower thread as shown in the illustration below. For upper thread trimming specifications (-00)

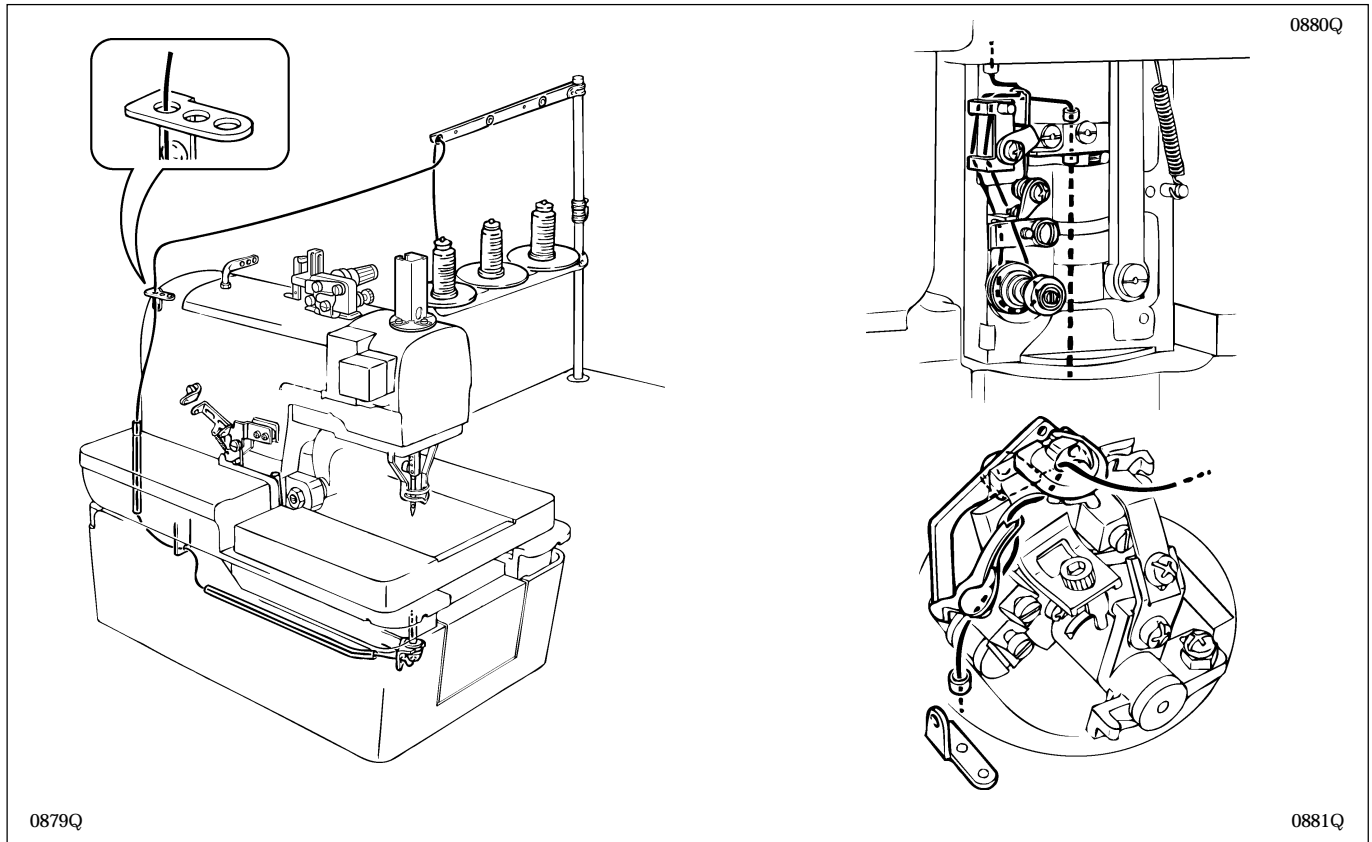

For upper and lower thread trimming specifications (-01, -02)

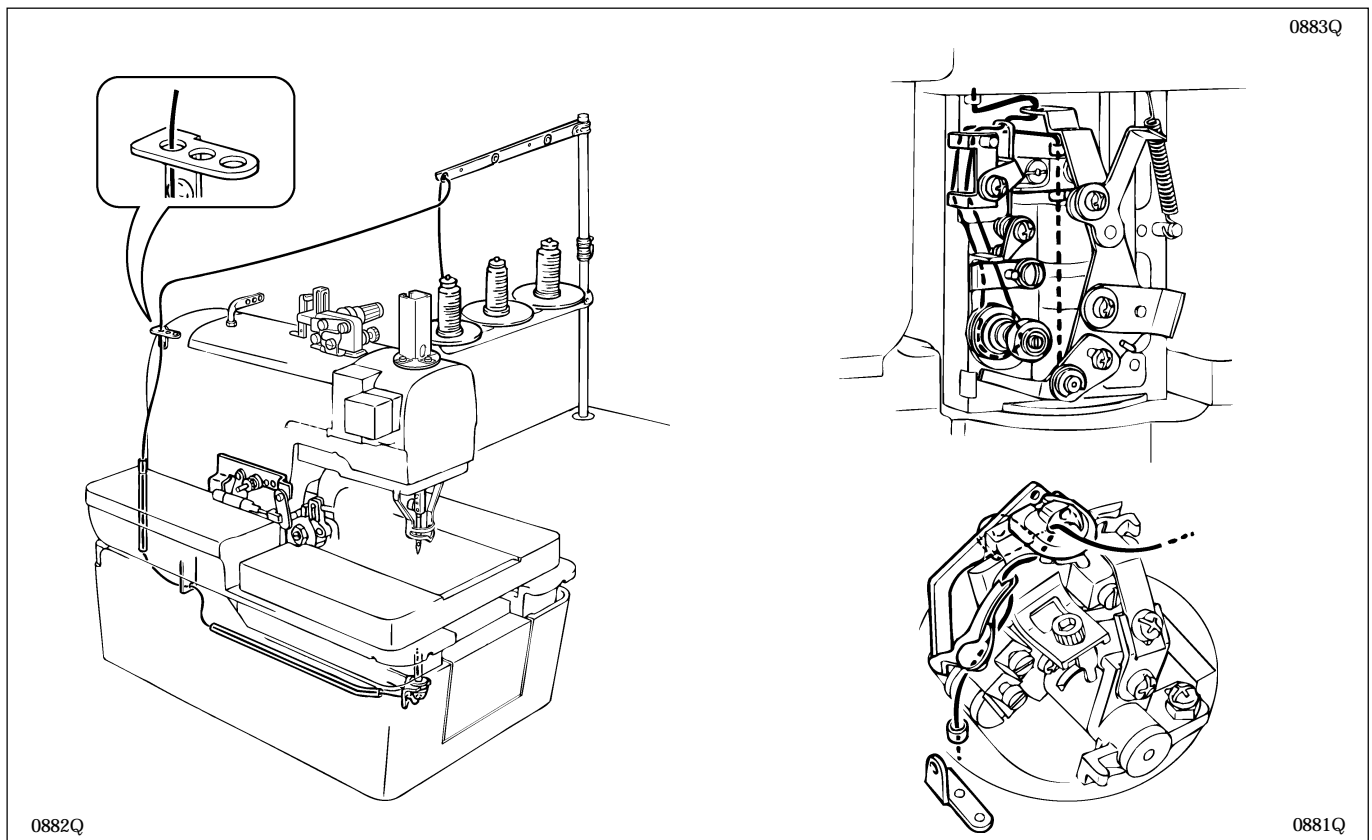

5-7. Threading the gimp

Remove the cloth presser plates (refer to page 13), and then thread the gimp as shown in the illustration below. Once threading is complete, replace the cloth presser plates.

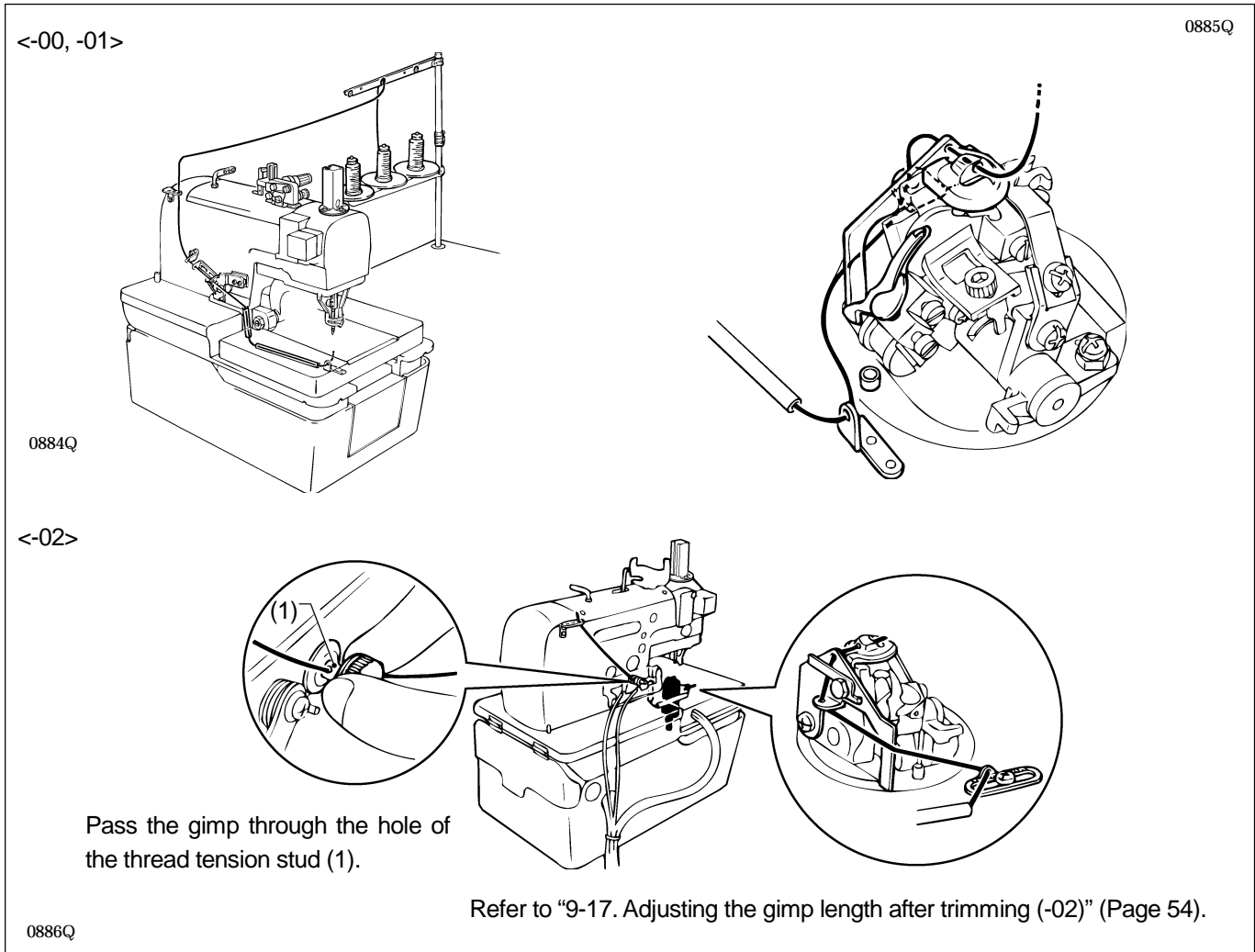

5-8. Setting the material

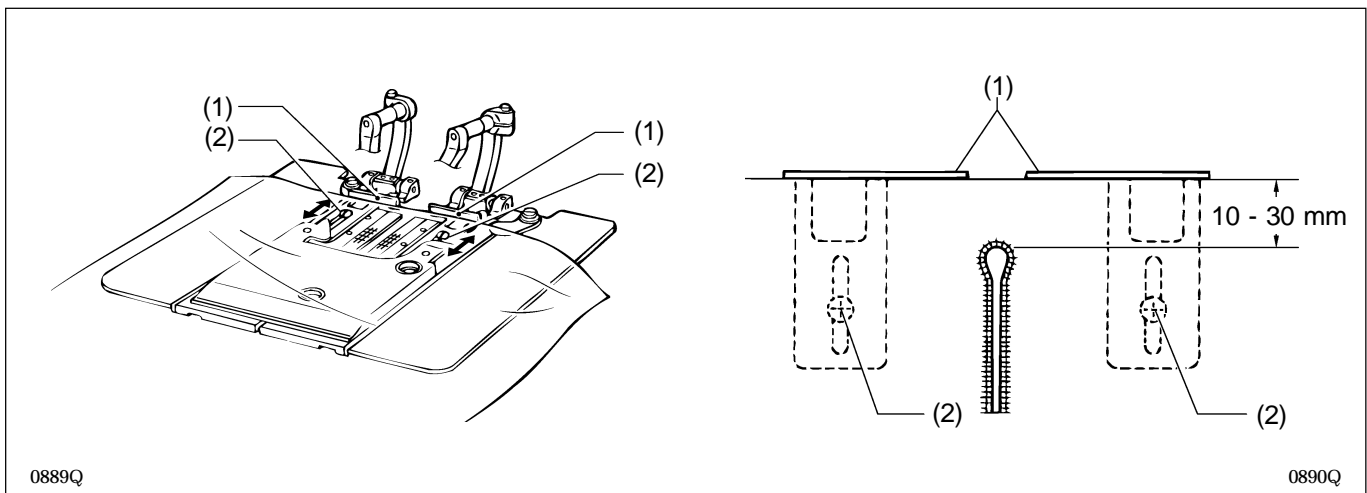

1. Insert the material so that it touches the right and left cloth guides (1).
2. The sewing margin can be adjusted to within 10 - 30 mm.
3. Loosen the screws (2) at left and right and move the cloth guides (1) back and forth to adjust the sewing margin.

6. USING THE OPERATION PANEL AND FRONT PANEL

6-1. Panel button and switch names

Operation panel part names

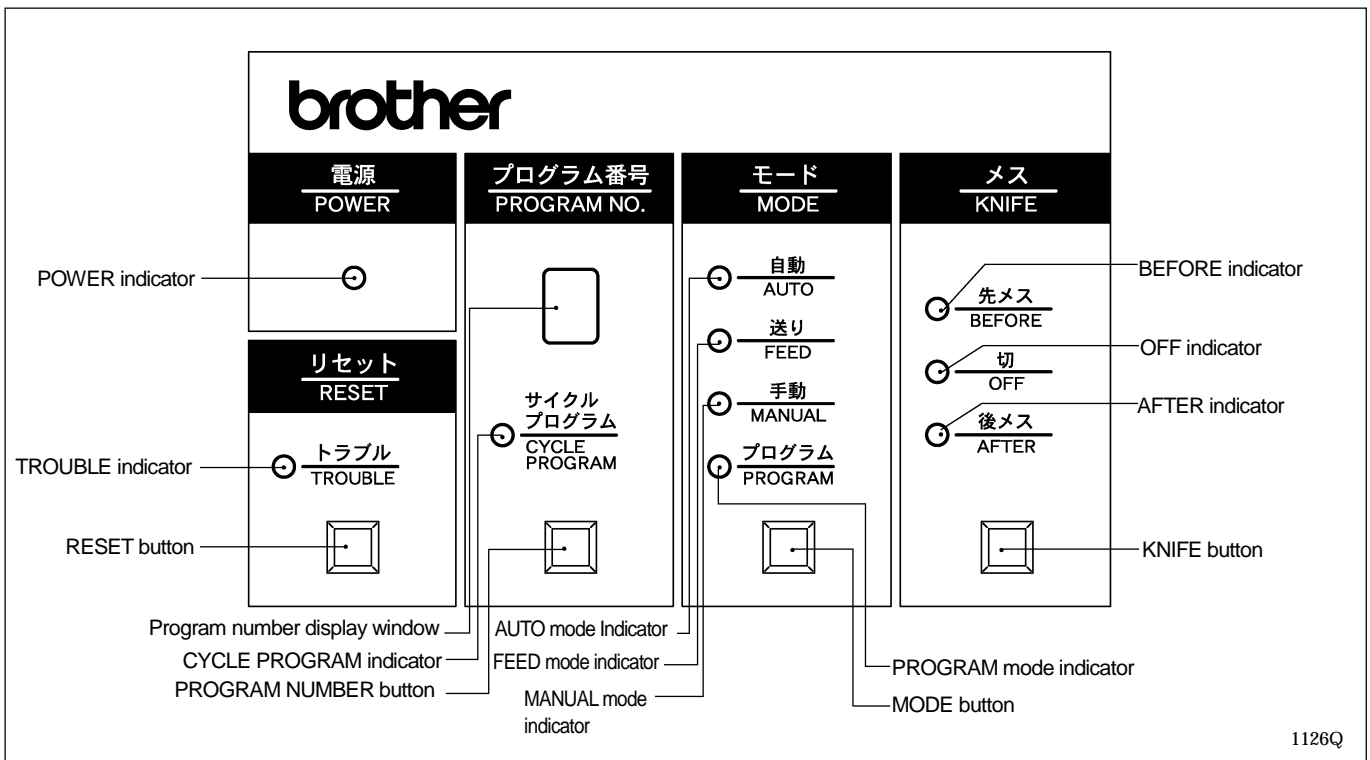

Front panel part name

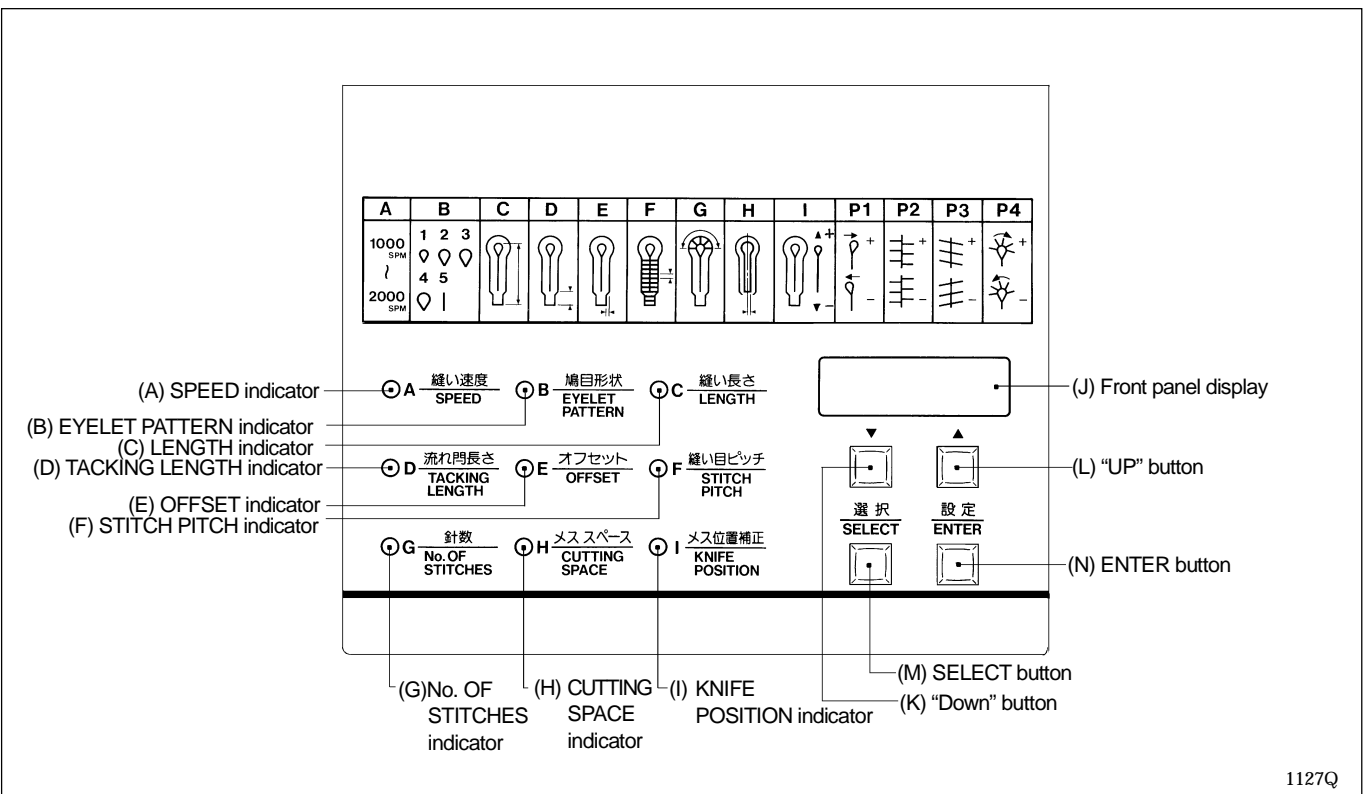

6. USING THE OPERATION PANEL AND FRONT PANEL

If the power is turned on and the RESET switch is then pressed, the feed bracket will move to the cloth setting position. Operations such as selecting a program number, changing the operation mode and selecting the cutting method can then be carried out.

6-2. Selecting a program number

A maximum of nine different eyelet shapes can be programmed.

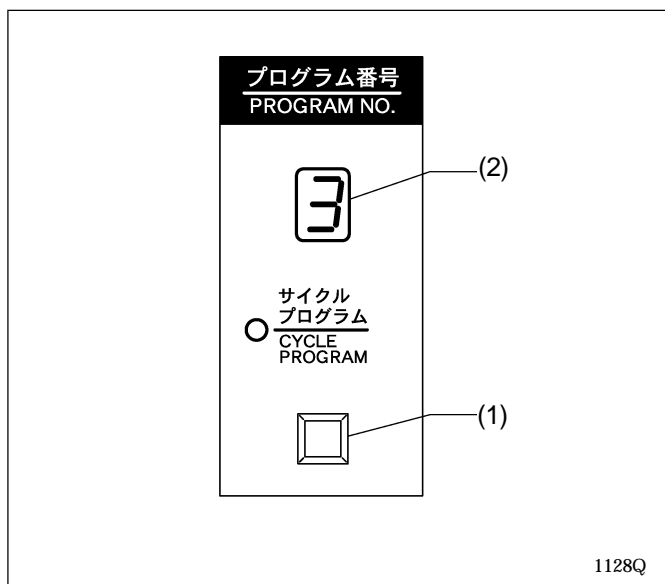

1. Press the PROGRAM NUMBER button (1). (Check which of the mode indicator illuminates.)

In automatic, feed or manual mode, the program numbers are displayed in the program number display window (2) in the following order each time the button is pressed.
→ 1 → 2 9

Note: If cycle programs have been input, the sequence will be as follows:

→ 1 → 2 9 → □ → □ → □ → □

(□ indicates a cycle program.)

- * In programming mode, the program numbers are displayed in the program number display window (2) in the following order each time the button is pressed.

→ 1 → 2 9 → C

6-3. Changing the mode

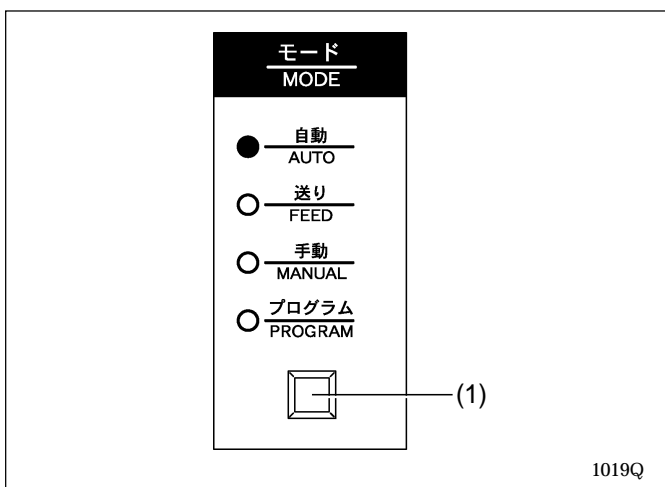

1. Press the MODE button (1).

- * The mode changes in the following order each time the button is pressed.

→ AUTO → FEED → MANUAL → PROGRAM

- Automatic mode is used for normal sewing.
- Feed mode is used to move the feed bracket with out sewing in order to check component positions.
- Use the Manual mode to check the machine operation when sewing by turning the upper shaft pulley by hand.
- Programming mode is used when setting programs.

6-4. Changing the cutting timing

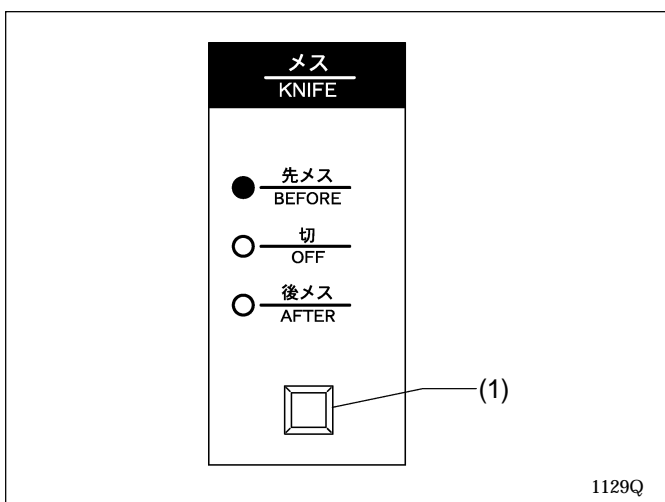

When "BEFORE" (cutting before sewing) is selected, the knife operates before the buttonhole is sewn.

When "OFF" (no cutting) is selected, the knife does not operate.

When "AFTER" (cutting after sewing) is selected, the knife operates after the buttonhole is sewn.

1. Press the KNIFE button (1).

- * The cutting timing changes in the following order each time the button is pressed.

→ BEFORE → OFF → AFTER

6-5. Setting a program

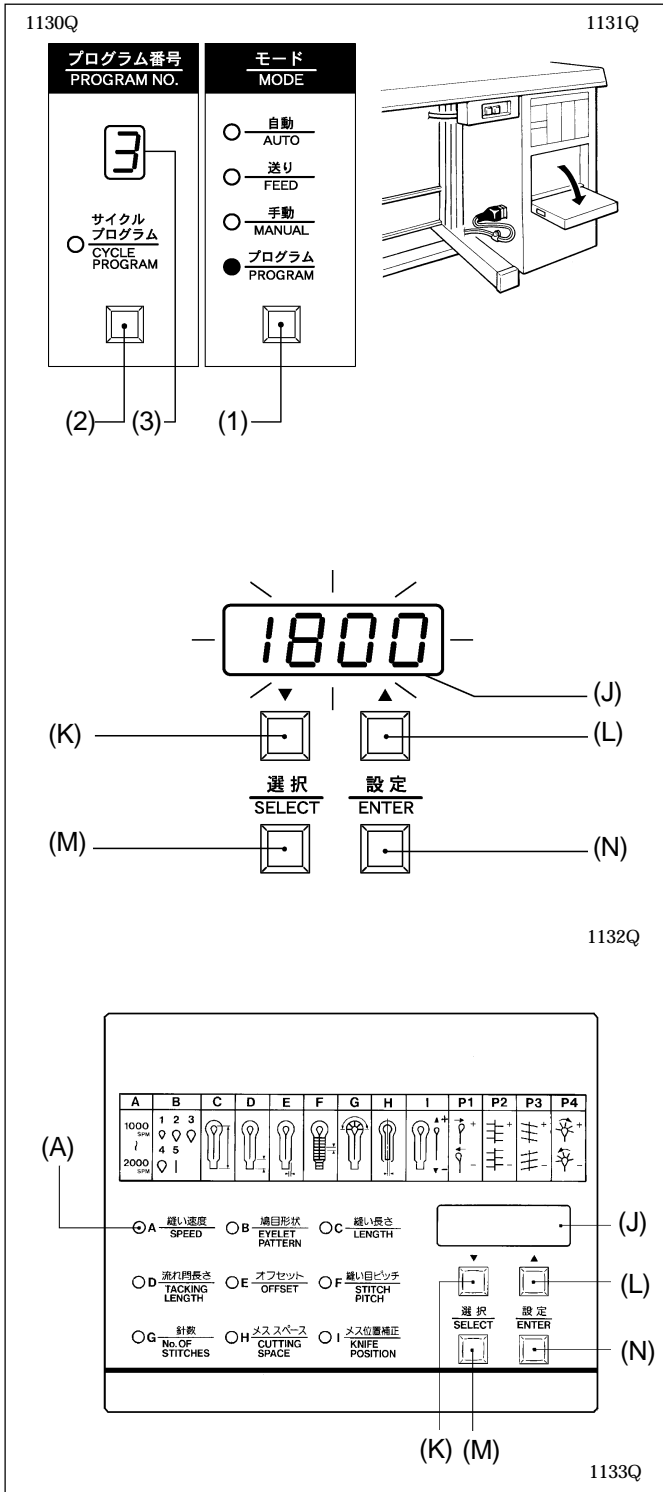

1. Push the section on the front panel marked "PUSH" to open the front panel.
2. Press the MODE button (1) to switch to programming mode.
Programming will not be possible unless the PROGRAM indicator is illuminated.
* The SPEED indicator (A) will illuminate and the current sewing speed appear on the front panel display (J).
3. Press the PROGRAM NUMBER button (2) until the desired program number appears in the program number display window (3).

4. Press the SELECT button (M) to select a letter from "A" to "P4."
* The character displayed changes in the following order each time the button is pressed.
→A→B P4→

Then make the required settings by following steps 5. and 6. below.

5. Press the "Up" button (L) or the "Down" button (K) to change the setting value.
* When the setting value is changed, the numerals appearing in the display will flash.
6. Press the ENTER button (N) to accept the changed value.
* The display will stop flashing.

Note: If you press the SELECT button (M) or the MODE button (1) while the display is still flashing, the setting value will not be changed.

6. USING THE OPERATION PANEL AND FRONT PANEL

A. Setting the sewing speed

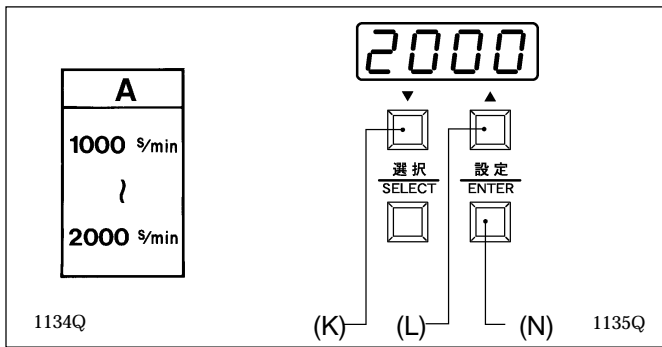

1. The sewing speed can be set to between 1000 - 2000 rpm in 11 100-rpm steps.
* When the setting value is being changed, the numerals appearing in the display will flash.
2. Press the "Up" button (L) or the "Down" button (K) to set the desired sewing speed.
* The display will stop flashing.
3. Press the ENTER button (N) to accept the new sewing speed setting.
* The display will stop flashing.

B. Setting the shape of the eyelet

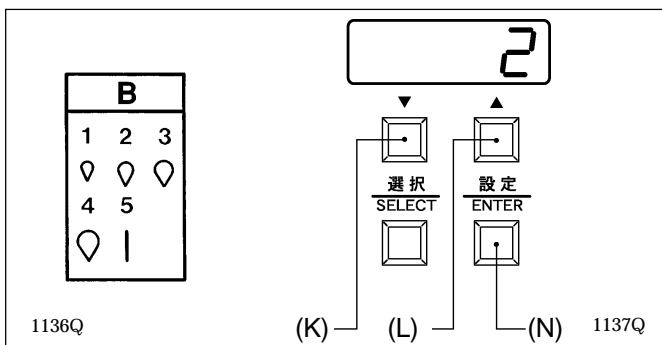

1. The eyelet can be set to one of five different shapes in accordance with the different shapes of knife. The No. 2 knife is installed as the default knife for standard specifications.
* When the setting value is being changed, the numerals appearing in the display will flash.
2. Select the same eyelet number as the number of the knife which is being used.
3. Press the "Up" button (L) or the "Down" button (K) to set the desired eyelet shape.
* The display will stop flashing.
4. Press the ENTER button (N) to accept the new eyelet shape setting.
* The display will stop flashing.

C. Setting the buttonhole length

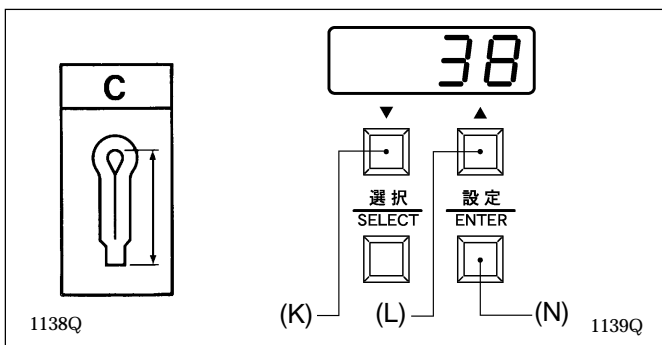

- <-00, -01>
1. The buttonhole can be set to a length of between 10 and 38 mm (10 to 50 mm with no looper thread trimmer) in steps of 1 mm.
Note: You cannot set the buttonhole length to a value that would make the difference between the buttonhole length and the tacking length less than 7 mm.
* When the setting value is being changed, the numerals appearing in the display will flash.
 2. Press the "Up" button (L) or the "Down" button (K) to set the desired buttonhole length.
* The display will stop flashing.
 3. Press the ENTER button (N) to accept the new buttonhole length setting.
* The display will stop flashing.

<-02>

The setting range is limited by the machine specifications (L1 - L7).

Example: For L1 specifications

1. The buttonhole can be set to a length of between 14 - 18 mm in steps of 1 mm.
Note: You cannot set the buttonhole length to a value that would make the difference between the buttonhole length and the tacking length less than 7 mm.
2. Press the "Up" button (L) or the "Down" button (K) to set the desired buttonhole length.
* When the setting value is being changed, the numerals appearing in the display will flash.
3. Press the ENTER button (N) to accept the new buttonhole length setting.
* The display will stop flashing.

The buttonhole lengths for L2 - L7 specifications can also be set in steps of 1 mm.

D. Setting the tacking length

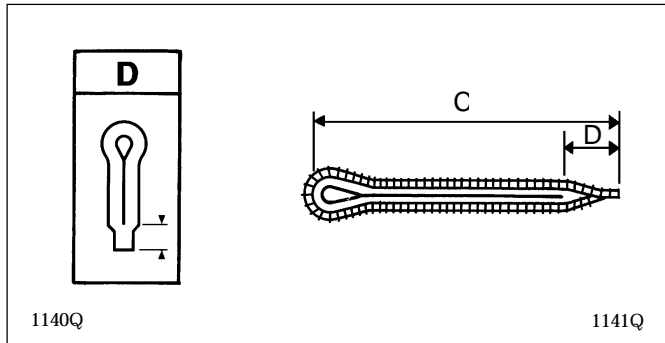

1. The tacking length can be set to between 3 and 43 mm in steps of 1 mm.
2. If not adding tacking, set the tacking length to "0". If this is done, it will not be possible to set a value for the offset.

Note: You cannot set the tacking length to a value that would make the difference between the buttonhole length and the tacking length less than 7 mm.

3. Press the "Up" button (L) or the "Down" button (K) to set the desired tacking length.
 - * When the setting value is being changed, the numerals appearing in the display will flash.
4. Press the ENTER button (N) to accept the new tacking length setting.
 - * The display will stop flashing.

E. Setting the offset

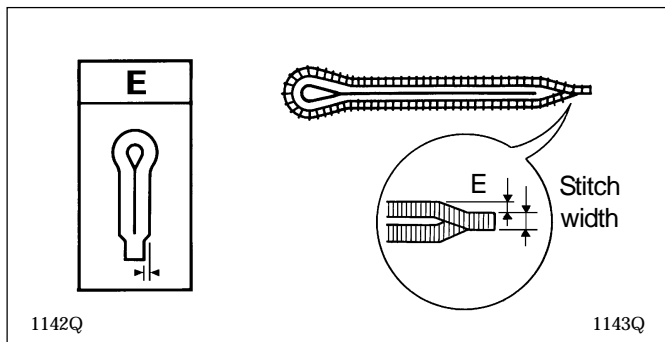

1. The offset can be set to between 0.5 and 2 mm in steps of 0.1 mm.

* The offset should normally be set to half the stitch width.
If a tacking length that is outside the 0 - 3 mm range is set, it will be set back to 1.5 mm automatically.

2. Press the "Up" button (L) or the "Down" button (K) to set the desired offset.
 - * When the setting value is being changed, the numerals appearing in the display will flash.
3. Press the ENTER button (N) to accept the new offset setting.
 - * The display will stop flashing.

Example: If the stitch width is 3 mm, set the offset to $3 \text{ mm} \div 2 = 1.5 \text{ mm}$.

However, fine adjustments to this value may be necessary depending on the material and/or the thread tension.

F. Setting the stitch pitch

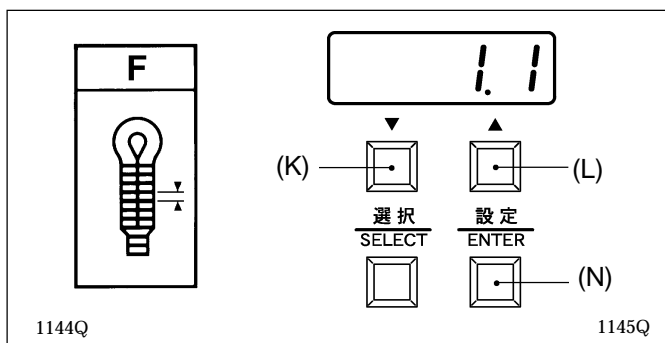

1. The stitch length can be set to between 0.5 and 2 mm in steps of 0.1 mm.
2. Press the "Up" button (L) or the "Down" button (K) to set the desired stitch length.

* When the setting value is being changed, the numerals appearing in the display will flash.

3. Press the ENTER button (N) to accept the new stitch length setting.
 - * The display will stop flashing.

6. USING THE OPERATION PANEL AND FRONT PANEL

G. Setting the number of eyelet stitches

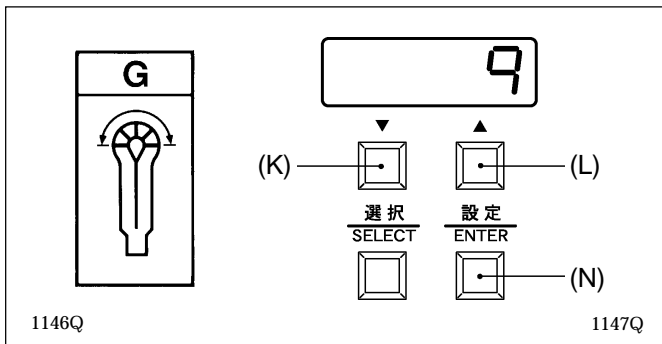

1. The number of eyelet stitches can be set to between 4 and 20 stitches in steps of 1 stitch.
2. Press the "Up" button (L) or the "Down" button (K) to set the desired number of eyelet stitches.
 - * When the setting value is being changed, the numerals appearing in the display will flash.
3. Press the ENTER button (N) to accept the new eyelet stitch number setting.
 - * The display will stop flashing.

H. Setting the cutting space

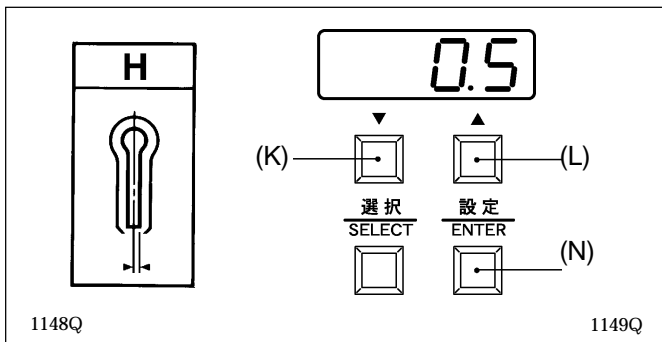

1. The cutting space can be set to between -0.3 and 0.5 mm in steps of 0.1 mm.
 - Note: You cannot set the cutting space to a value that would make the difference between the knife position compensation and the cutting space less than -0.7 mm.
2. Press the "Up" button (L) or the "Down" button (K) to set the desired cutting space.
 - * When the setting value is being changed, the numerals appearing in the display will flash.
3. Press the ENTER button (N) to accept the new cutting space setting.
 - * The display will stop flashing.

I. Setting the knife position compensation

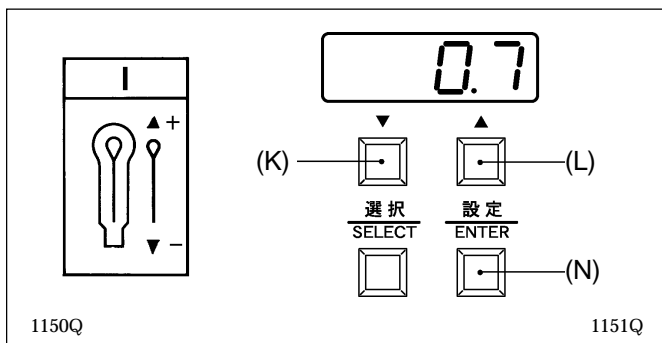

1. The knife position compensation can be set to between -0.7 and +0.7 mm in steps of 0.1 mm.
 - * If you would like to move the knife closer to the seam, set to a negative value; if you would like to move it away from the seam, set to a positive value.
 - Note: You cannot set the knife position compensation to a value that would make the difference between the knife position compensation and the cutting space less than -0.7 mm.
2. Press the "Up" button (L) or the "Down" button (K) to set the desired knife position compensation.
 - * When the setting value is being changed, the numerals appearing in the display will flash.
3. Press the ENTER button (N) to accept the new knife position compensation setting.
 - * The display will stop flashing.

P1. Setting X correction

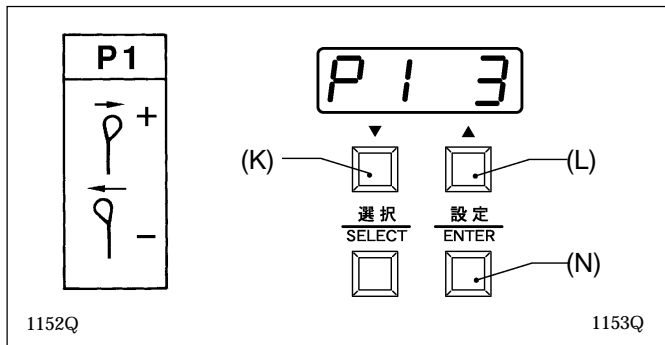

1. The setting range is from 1 to 6 in steps of 1.
 - * Set to a larger value if you would like to move the eyelet seam to the right (when seen from the finished side, or the reverse side when sewing).
2. Press the “up” button (L) or the “down” button (K) to set the X correction value.
 - * When the setting value is changed, the value displayed will start to flash.
3. Press the ENTER button (N) to accept the X correction setting.
 - * The display will stop flashing and will start illuminating steadily.

P2. Setting Y correction

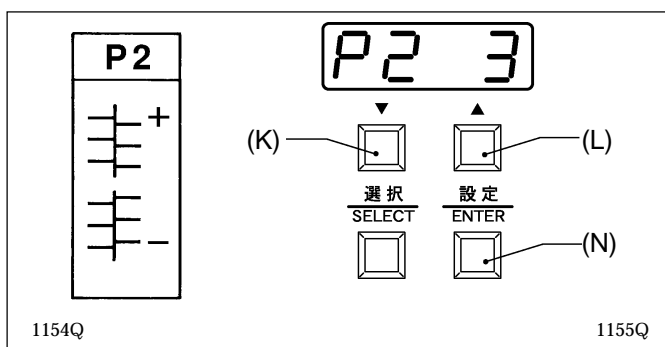

1. The setting range is from 1 to 6 in steps of 1.
 - * Set to a larger value if you would like to move the right-side seam further forward (when seen from the finished side, or the reverse side when sewing).
2. Press the “up” button (L) or the “down” button (K) to set the Y correction value.
 - * When the setting value is changed, the value displayed will start to flash.
3. Press the ENTER button (N) to accept the Y correction setting.
 - * The display will stop flashing and will start illuminating steadily.

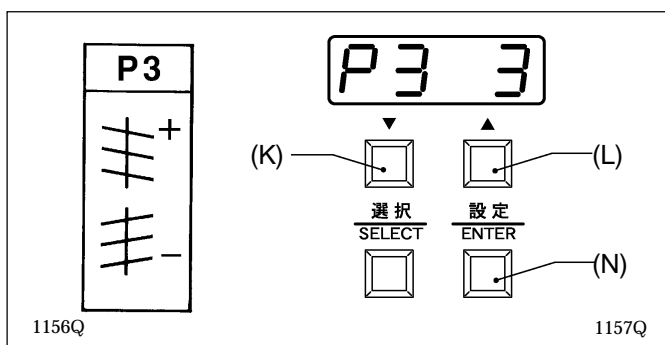
P3. Setting θ_1 correction

1. The setting range is from -3 to 3 in steps of 1.
 - * Set to a larger value if you would like to rotate the seam which is not part of the eyelet clockwise (when seen from the finished side, or the reverse side when sewing).
2. Press the “up” button (L) or the “down” button (K) to set the θ_1 correction value.
 - * When the setting value is changed, the value displayed will start to flash.
3. Press the ENTER button (N) to accept the θ_1 correction setting.
 - * The display will stop flashing and will start illuminating steadily.

6. USING THE OPERATION PANEL AND FRONT PANEL

P4. Setting θ_2 correction

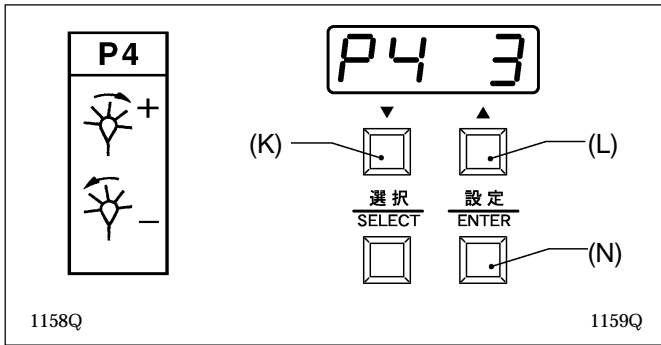

1. The setting range is from -3 to 3 in steps of 1.
 - * Set to a larger value if you would like to rotate the eyelet seam clockwise (when seen from the finished side, or the reverse side when sewing).
2. Press the “up” button (L) or the “down” button (K) to set θ_2 correction value.
 - * When the setting value is changed, the value displayed will start to flash.
3. Press the ENTER button (N) to accept the θ_2 correction setting.
 - * The display will stop flashing and will start illuminating steadily.

6-6. Using the memory switch

The conditions of the memory switches are memorized even if the power is OFF, however, if data of the memory switches are initialized, the memory switches will be returned to their initial settings (factory default settings).

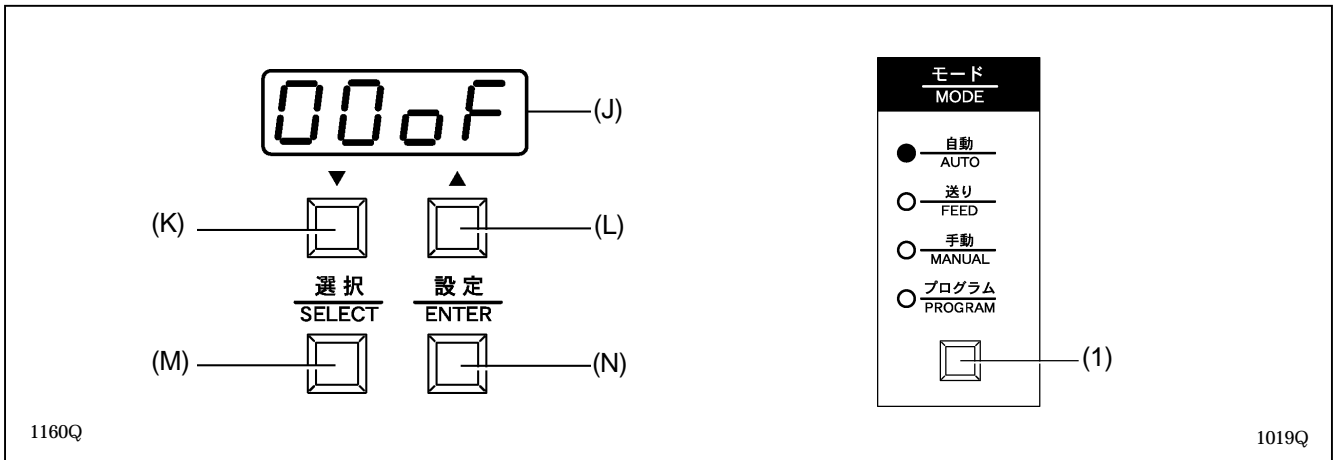

1. While pressing the SELECT button (M), press the power switch to turn on the power.
 - * The two left-side columns of the front panel display (J) are the memory switch number, and the two right-side columns show the memory switch setting (or value).
2. Press the SELECT button (M) to select the desired memory switch number.
 - * The setting range is from 00 to 99. However, numbers in unused ranges are skipped.
3. Press the "UP" button (L) or "DOWN" button (K) to select the desired memory switch number.
 - * For memory switches which can be set to ON or OFF, press the "UP" button (L) to set to "On", and press the "DOWN" button (K) to set to "OFF". "On" represents ON, and "OFF" represents OFF.
4. Press the ENTER button (N) to store the memory switch setting.
5. Press the MODE button (1).
 - * The TROUBLE indicator will flash and the sewing machine will go to normal standby mode.

No.	Contents	Setting range	Initial value
00	Bar tacking at the sewing start to prevent fraying	OFF: Disabled ON: Enabled	OFF
01	Number of stitches for memory switch No. 00 * Does not appear when memory switch No. 00 is set to OFF.	01: 1 stitch 02: 2 stitches 03: 3 stitches	01
02	Bar tacking at the sewing end to prevent fraying	OFF: Disabled ON: Enabled	OFF
03	Number of stitches for memory switch No. 02 * Does not appear when memory switch No. 02 is set to OFF.	01: 1 stitch 02: 2 stitches 03: 3 stitches	01
04	Work clamp operation selection when feed bracket is at front position (Set to OFF if the cutting block may strike the Work clamp.)	OFF: The work clamp passes underneath the cutting block, then rises and moves forward. ON: The work clamp rises and then moves forward.	OFF
05	Eyelet buttonhole sewing speed setting	OFF: Same speed as speed A set at the front panel. ON: Different speed from speed A set at the front panel.	OFF
06	Speed for memory switch No. 05 (If the speed is set to a higher value than speed A that has been set at the front panel, the speed will not exceed speed A.) * Does not appear when memory switch No. 05 is set to OFF.	10: 1,000rpm, 11: 1,100rpm, 12: 1,200rpm, 13: 1,300rpm, 14: 1,400rpm, 15: 1,500rpm, 16: 1,600rpm, 17: 1,700rpm, 18: 1,800rpm, 19: 1,900rpm, 20: 2,000rpm	18

6. USING THE OPERATION PANEL AND FRONT PANEL

No.	Contents	Setting range	Initial value
07	Y direction offset for return seam to prevent thread breakage	OFF: No offset ON: Offset by 1/2 pitch	OFF
08	Sewing end pitch for buttonhole taper to prevent fraying	OFF: No change ON: Change	OFF
09	No. of stitches before pitch change for memory switch No. 08 * Does not appear when memory switch No. 08 is set to OFF.	01: 1 stitch, 02: 2 stitches, 03: 3 stitches, 04: 4 stitches, 05: 5 stitches	01
10	No. of stitches after pitch change for memory switch No. 08 * Does not appear when memory switch No. 08 is set to OFF.	01: 1 stitch, 02: 2 stitches, 03: 3 stitches, 04: 4 stitches, 05: 5 stitches, 06: 6 stitches, 07: 7 stitches, 08: 8 stitches, 09: 9 stitches	01
11	Test feeding speed	OFF: Standard speed ON: Low speed	OFF
12	Speed for memory switch No. 11 * Does not appear when memory switch No. 11 is set to OFF.	20: 20% of standard speed 35: 35% of standard speed 50: 50% of standard speed	50
13	Knife operation (BEFORE/OFF/AFTER) setting	OFF: Setting not possible within cycle program ON: Setting possible within cycle program	OFF
14	Special lapel cutting device	OFF: Disabled ON: Enabled	OFF
15	Button hole sensor (Special lapel cutting device)	OFF: Disabled ON: Enabled	OFF
16	Timer for checking lowering of cutting block (Timer for determining if cutting block is lowered)	OFF: Disabled (Determined from slit signal stopping) ON: Enabled (Determined by timer)	OFF
17	Time for memory switch No. 16 * Does not appear when memory switch No. 16 is set to OFF.	42: 420 ms, 45: 450ms, 48: 480ms, 51: 510ms, 54: 540 ms	45
18	Changing cutting block ON time * Disabled (always "OFF") when memory switch No. 16 is "ON"	OFF: Disabled (25 ms) ON: Enabled	OFF
19	Time for memory switch No. 18 * Does not appear when memory switch No. 18 is set to OFF.	05: 50 ms, 10: 100ms, 15: 150ms, 20: 200 ms	05
20	Timer for checking raising of cutting block (Timer for determining if the cutting block has been raised to a position where it will not touch the next feed bracket to operate)	OFF: Disabled (Determined from number of slit signals) ON: Enabled (Determined by timer)	OFF
21	Time for memory switch No. 20 * Does not appear when memory switch No. 20 is set to OFF.	15: 150ms, 20: 200 ms, 25: 250ms, 30: 300ms, 35: 350ms, 40: 400ms, 45: 450ms, 50: 500ms	20
22	Cutting block raising check timer (Raised position of the cutting block is determined from the number of slit signals, and timer is updated) * Disabled (always "OFF") when memory switch No. 20 is "ON"	OFF: Disabled ON: Enabled	OFF
23	Time for memory switch No. 22 * Does not appear when memory switch No. 22 is set to OFF.	05: 50 ms, 10: 100ms, 15: 150ms, 20: 200 ms, 25: 250ms, 30: 300ms, 35: 350ms, 40: 400ms	05
24	Setting tacking length to 0 for straight tacking specifications	OFF: Disabled ON: Enabled	OFF
25 99	Spare	-	-

6-7. List of error codes

If the buzzer sounds and an error code starting with "E" appears in the front panel display, check according to the table below.

Codes E-00 to E-16 are errors which are displayed when the power is turned on. Codes E-30 to E-59 are resetting errors which are displayed before operation and after the EMERGENCY STOP switch is pressed. Codes E-60 to E-89 represent errors which occur during operation.

Code	Explanation	Resetting method
E-00	EMERGENCY STOP switch was pressed.	Press the EMERGENCY STOP switch once more and then press the RESET button.
E-02	Machine head is raised (safety switch is off).	Turn off the power.
E-03	Cloth presser switch was pressed.	Release the cloth presser switch and then press the RESET button.
E-04	Start switch was pressed.	Release the start switch and then press the RESET button.
E-05	RESET button was pressed.	Turn off the power.
E-09	Sewing specifications changeover harness and stitch length changeover harness and PROM version do not match.	Turn off the power.
E-10	Needle bar is not at the highest position.	Raise the needle to the needle up position and then press the RESET button.
E-12	Cutting block is lowered.	Turn off the power.
E-15	Lower thread and gimp trimming knife does not retract.	Turn off the power.
E-16	Upper thread trimming knife does not retract.	Turn off the power.
E-30	EMERGENCY STOP switch was pressed.	Press the EMERGENCY STOP switch once more and then press the RESET button.
E-32	Machine head is raised (safety switch is off).	Turn off the power.
E-35	RESET button was pressed.	Turn off the power and then press the RESET button.
E-40	Needle bar has not been raised.	Raise the needle to the needle up position and then press the RESET button.
E-42	Cutting block is lowered.	Turn off the power.
E-45	Lower thread and gimp trimming knife does not retract.	Turn off the power.
E-46	Upper thread trimming knife does not retract.	Turn off the power.
E-50	X axis is not at the home position.	Turn off the power.
E-51	Y axis is not at the home position.	Turn off the power.
E-52	θ axis is not at the home position	Turn off the power.
E-59	Sewing data has been corrupted (checked for each program).	Turn off the power.
E-60	EMERGENCY STOP switch was pressed.	Press the RESET button (to interrupt) or the start switch (to continue).
E-62	Machine head is raised (safety switch is off).	Turn off the power.
E-69	Needle bar does not stop at the highest position.	Raise the needle to the needle up position and then press the start switch (to continue).
E-70	Needle up signal does not turn on and off during operation.	Turn off the power.
E-71	Needle down signal does not turn on and off during operation.	Turn off the power.
E-72	Cutting block operation is incorrect.	Turn off the power.
E-75	Lower thread and trimming operations are incorrect.	Turn off the power.
E-76	Upper thread operation is incorrect.	Turn off the power.
E-80	When the feed bracket returns to the home position, the X axis is not at the home position.	Turn off the power.
E-81	When the feed bracket returns to the home position, the Y axis is not at the home position.	Turn off the power.
E-82	When the feed bracket returns to the home position, the θ axis is not at the home position.	Turn off the power.
E-89	Machine operation direction is reversed.	Turn off the power.
E-91	Pulse motor overcurrent	Turn off the power.

Note: Errors E-50, E-51 and E-52 are not errors to be reset after the EMERGENCY STOP switch is pressed.

7. SEWING

Make sure you know where the EMERGENCY STOP switch is and how it is used before operating the sewing machine.

7-1. Using the EMERGENCY STOP switch

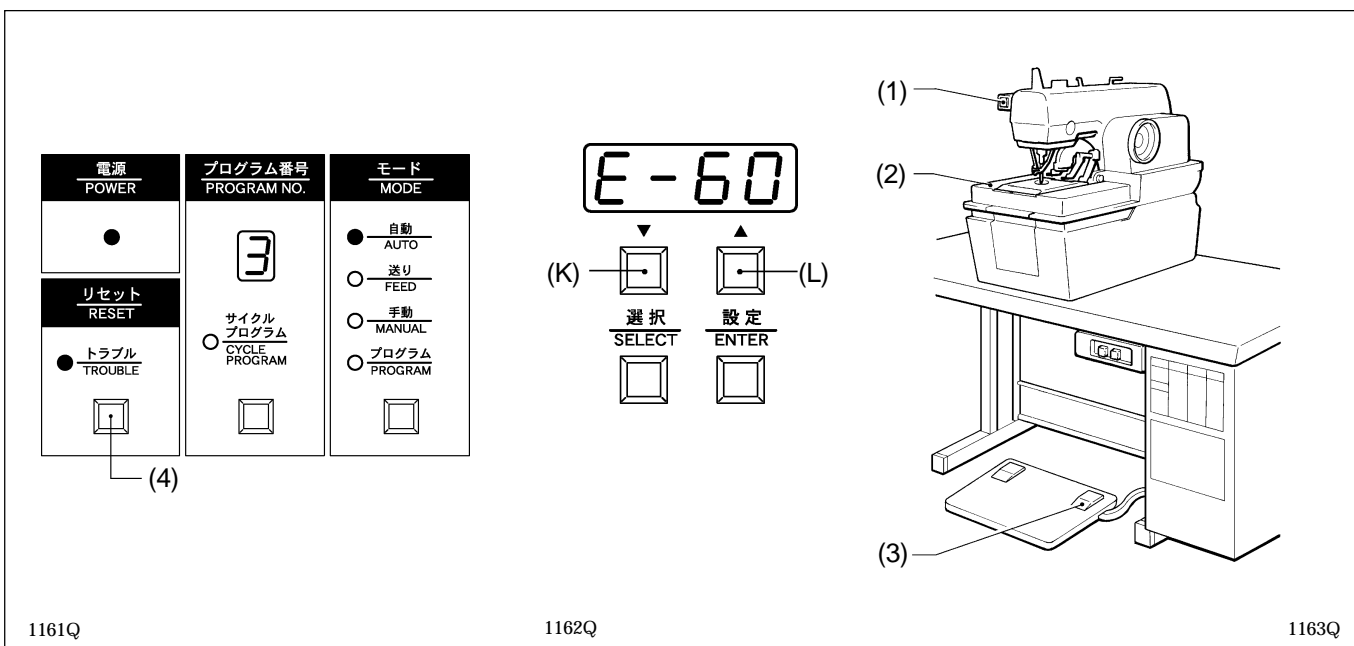

In automatic mode

1. Press the EMERGENCY STOP switch (1).

* All machine operations will stop and the buzzer will sound. The TROUBLE indicator will illuminate and "E-60" will appear on the front panel display at this time.

2. Eliminate the cause of the problem.

* The machine will not always stop in the needle up position if the EMERGENCY STOP switch (1) is pressed during sewing.

Turn the upper shaft pulley by hand to raise the needle to the needle up position (so that the marks are aligned).

* The feed bracket (2) can be moved back and forth at this time by pressing the "up" button (L) and "Down" button (K).

3. To continue sewing, press the start switch (3).

* The TROUBLE indicator will switch off, the "E-60" will be cleared from the front panel display and sewing will begin again.

To stop sewing, press the RESET button (4).

* The TROUBLE indicator will switch off, the "E-60" will be cleared from the front panel display and the feed bracket will return to the cloth setting position.

In manual mode or in automatic mode

1. Press the EMERGENCY STOP switch (1).

* All machine operations will stop and the buzzer will sound. The TROUBLE indicator will illuminate and "E-60" will appear on the front panel display at this time.

2. Eliminate the cause of the problem.

3. Press the RESET button (4).

* The TROUBLE indicator will switch off, the "E-60" error code will be cleared from the front panel display and the feed bracket will return to the cloth setting position.

7-2. Sewing

⚠ CAUTION



Turn off the power switch at the following times, otherwise the machine may operate if the start switch is pressed by mistake, which could result in injury.

- When threading the needle
- When replacing the needle
- When not using the machine and when leaving the machine unattended



Do not touch any of the moving parts or press any objects against the machine while sewing, as this may result in personal injury or damage to the machine.

When carrying out automatic sewing for the first time, be sure to carry out a test sewing first.

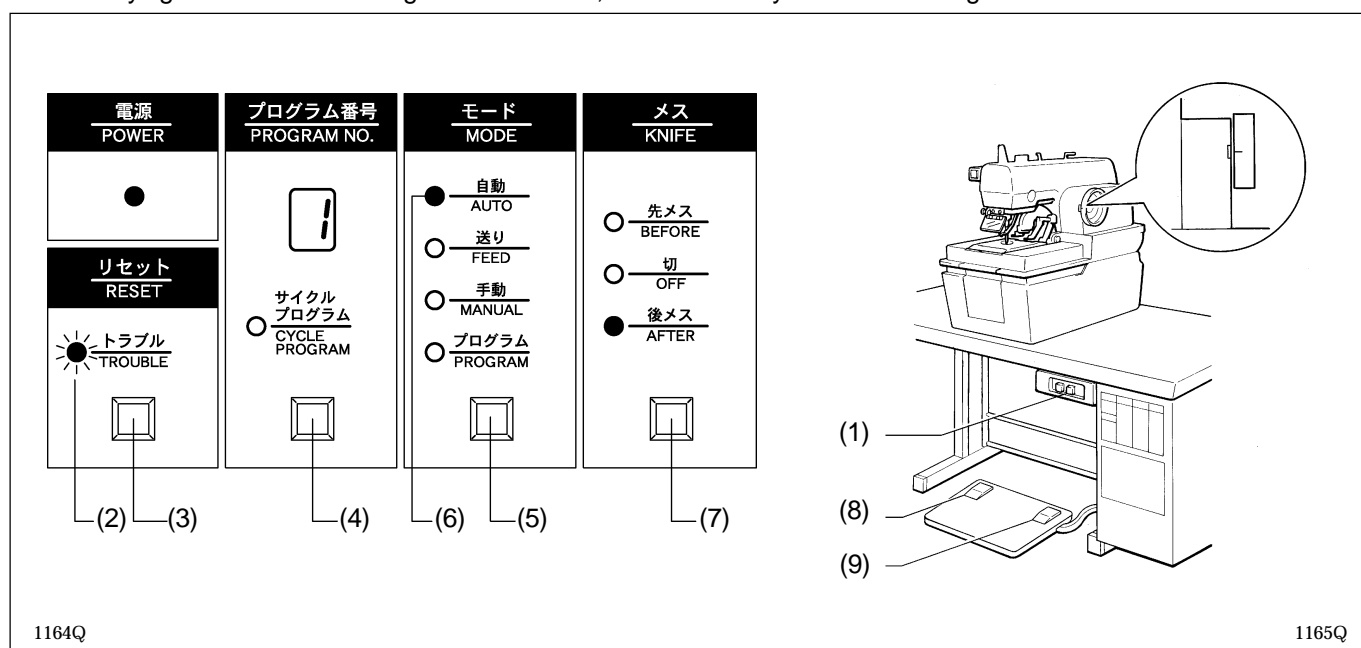

1. Press the power switch (1) to turn on the power.
 - * The POWER indicator will illuminate and the TROUBLE indicator (2) will flash.
2. Press the RESET button (3).
 - * The TROUBLE indicator (2) will switch off and the feed bracket will move to the cloth setting position.
 - * If the buzzer sounds and "E-10" appears on the front panel display (J) at this time, turn the pulley to set the needle to its upper position, and press the RESET button (3).
3. Press the PROGRAM NUMBER button (4) to select the desired program number. (Refer to page 20.)
4. Press the MODE button (5) to switch to automatic mode.
 - * The AUTO indicator (6) will illuminate.
5. Press the KNIFE button (7) to select cutting before sewing, OFF (no cutting) or cutting after sewing. (Refer to page 20.)
6. Place the material to be sewn under the cloth presser and press the cloth presser switch (8) to lower the cloth presser, and then release the cloth presser switch (8).
7. Press the start switch (9). Sewing will then start.
8. When sewing is finished, the cloth presser will be raised.

To repeat this operation, repeat steps 6. and 7. above.

Note: After you have finished the machine and have turned the power off, the previous sewing data will still be retained in memory even when the power is turned back on again. Thus you can continue with the same type of sewing.

Check the thread tension after sewing. Refer to the following page.

7-3. Adjusting the thread tension

Turn off the power.

Never adjust the thread tension while sewing.

<Reference values>

	Woolen materials + wool gimps	Denim (3 layers)
Upper thread tension	0.9 N	1.0 N
Lower thread tension	0.3 N	0.8 N
Thread take-up spring tension	0.05 N	0.07N
Thread take-up spring stroke	8 mm	8 mm
Upper and lower thread	# 30 polyester	# 30 cotton

* If you change the type of material being used, it may be necessary to change the thread tension.

The upper thread tension given above is the tension when the upper thread is pulled out from the thread path hole of the thread take-up lever, and the lower thread tension is when the lower thread is pulled out from the needle hole in the throat plate.

Upper thread tension

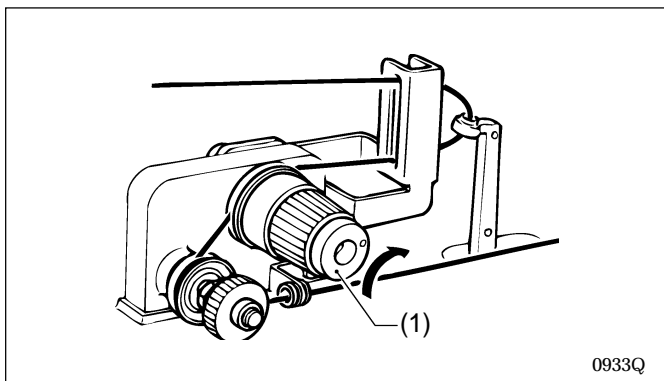

Turn the upper thread tension adjustment knob (1) in the direction indicated by the arrow to increase the upper thread tension.

Lower thread tension

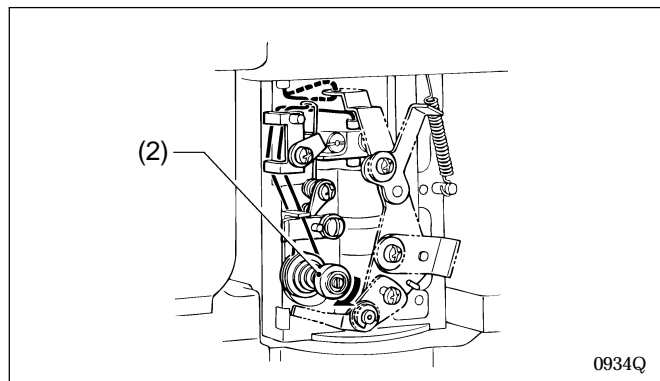

Turn the lower thread tension adjustment knob (2) in the direction indicated by the arrow to increase the lower thread tension.

Adjusting the lower thread take-up spring tension and stroke

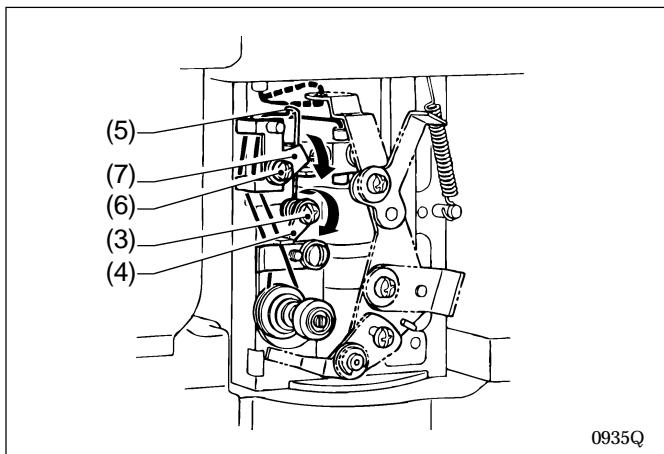

Tension adjustment

Loosen the screw (3) and turn the thread take-up spring support (4) in the direction indicated by the arrow to increase the tension of the spring (5).

Stroke adjustment

Loosen the screw (6) and turn the thread take-up spring guide (7) in the direction indicated by the arrow to increase the stroke of the spring (5).

7-4. Needle and knife position

The feed bracket is electronically controlled by means of pulse motors.

It is not necessary to change the position of the knife when switching between cutting before sewing and cutting after sewing. It is not necessary to change the needle down position in order to keep enough space for cutting when cutting after sewing has been selected.

Relationship between knife position and eyelet shape

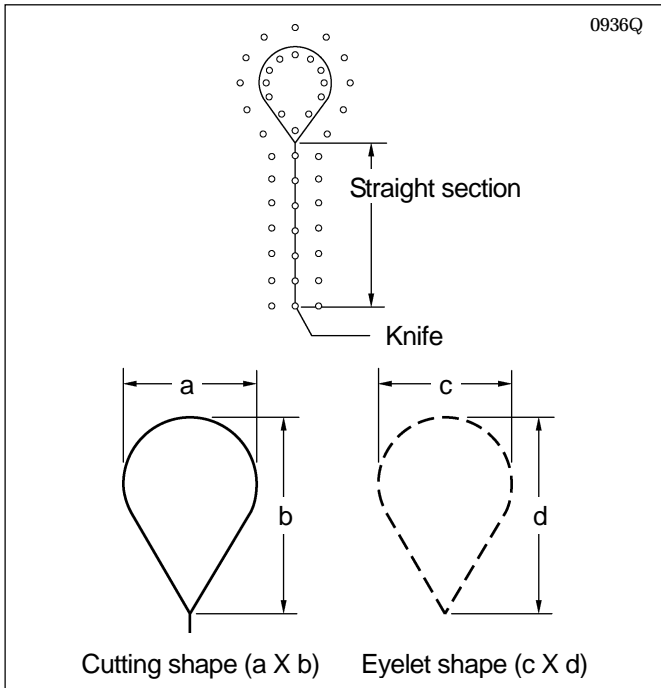

1. When cutting before sewing, the inside needle down position must be aligned accurately with the straight line section of the eyelet (when the cutting space H is 0).

This is set correctly at the time of shipment from the factory.

2. The shape of the eyelet is automatically changed according to the shape of the knife for cutting before and after sewing and for no cutting.

Knife No.	Cutting shape (a X b)	Eyelet shape (c X d)	
		Cutting before sewing or off (no cutting)	Cutting after sewing
1	2.1 X 3.2	1.9 X 2.8	2.4 X 3.9
2	2.8 X 4.3	2.4 X 3.9	3.3 X 4.6
3	3.0 X 4.6	3.2 X 4.1	3.6 X 4.8
4	3.2 X 5.4	2.8 X 4.7	3.6 X 6.1
5	Straight	Straight	Straight
6	3.8 X 4.3	3.2 X 3.6	4.0 X 4.5

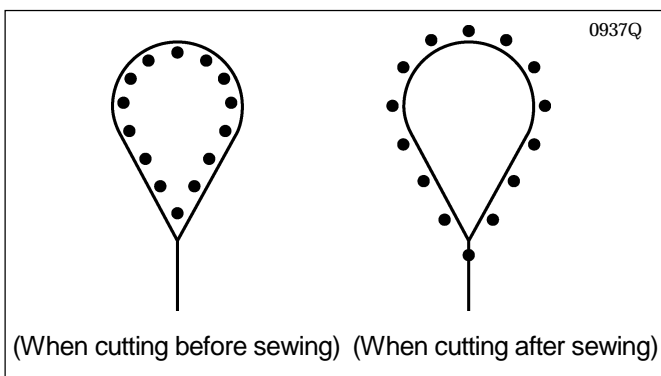

3. At the time of shipment, the installation position for the knife is adjusted to the position shown in the illustration at left (when the cutting space H and the knife position compensation value I are "0").

Explanation of the cutting space function

When cutting after sewing, this function moves the outer needle down positions in accordance with the knife shape so that the seam is not cut by the knife.

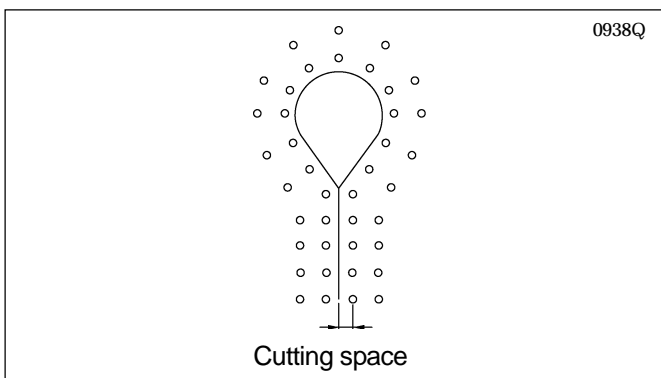

1. When cutting after sewing, set the cutting space H to an appropriate value so that the seam is not cut by the knife.

* The cutting space H should generally be set to around 0.2 - 0.3. (Refer to page 24 for details on the setting method.)

* The knife position compensation value I should be set to "0".

Refer to "H. Setting the cutting space" and "I. Setting the knife position compensation".

Knife position compensation function

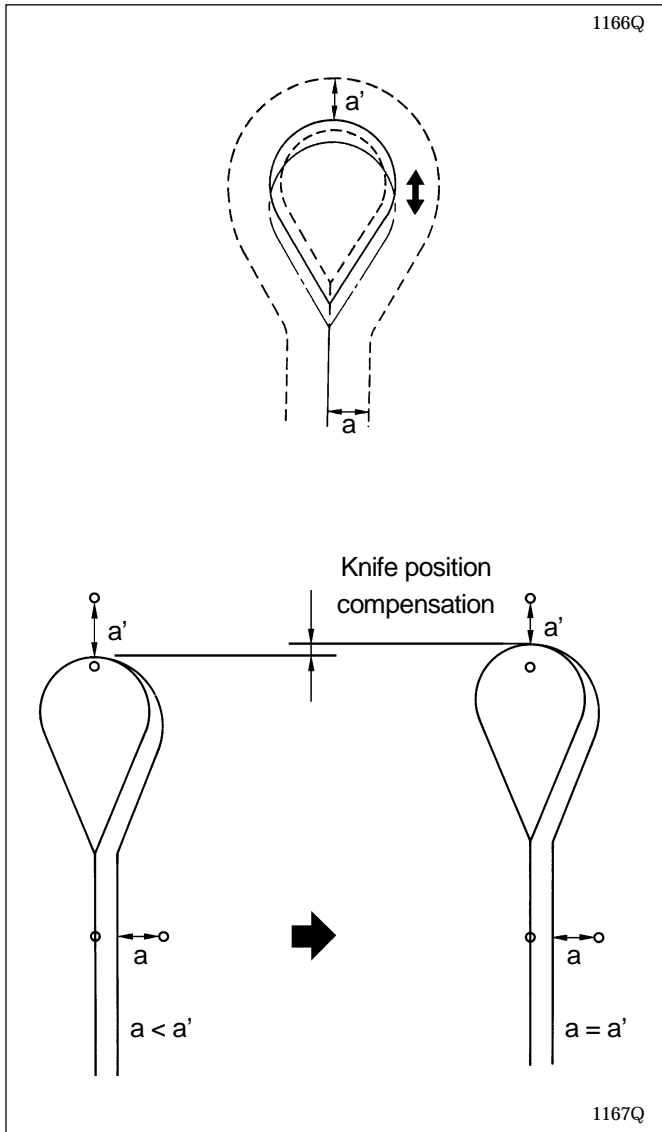

This function moves the knife with respect to the seam in order to ensure that distances a and a' are equal.

1. When cutting before sewing, the difference between a and a' will change depending on the cloth opening amount.
2. Set the knife position compensation value I so that the two are equal.
(Move the knife to the positive direction (+) when increasing the cloth opening amount.
Refer to "1. Setting the knife position compensation" on page 24.)

7-5. Using the production counter

The production counter is initially set to the counting up from zero method. It can display up to a maximum count of 9999.

* If DIP switch No. 4 inside the front panel is set to OFF, the counting up from zero method will be used. If DIP switch No. 4 is set to ON, the counting down to zero method will be used.

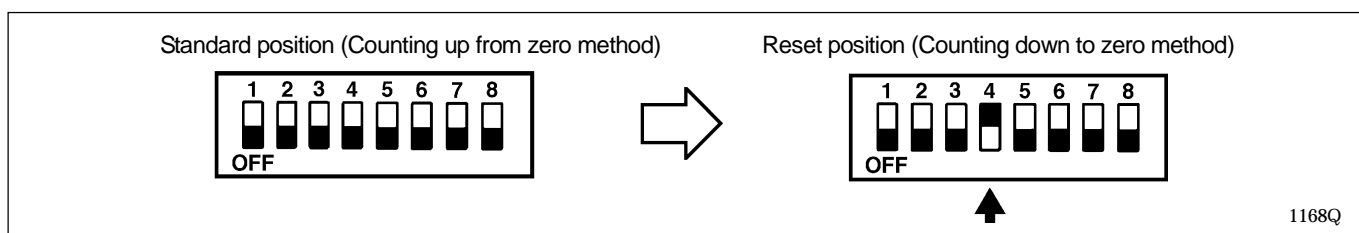

Displaying the production counter

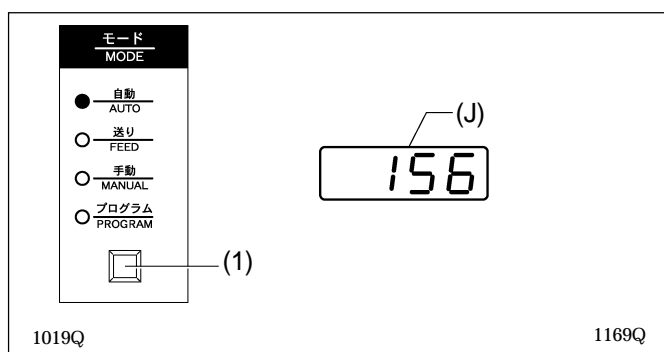

1. Press the MODE button (1) to switch to automatic mode.

* The production counter will appear in the front panel display (J).

Resetting the production counter

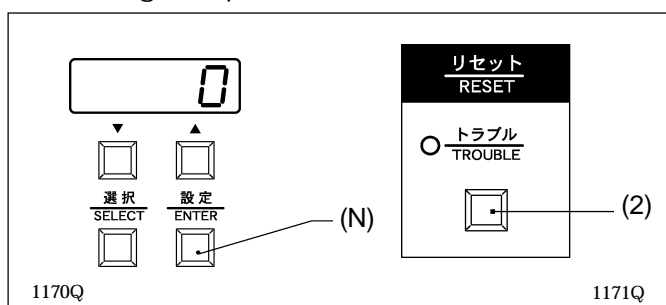

Counting up from zero method

1. Press the MODE button (1) to switch to automatic mode.
2. Press the ENTER button (N).

* The units digit will start flashing in the display.

3. Press the RESET button (2).

* The units digit will change to "0" and the counter value will be reset to "0".

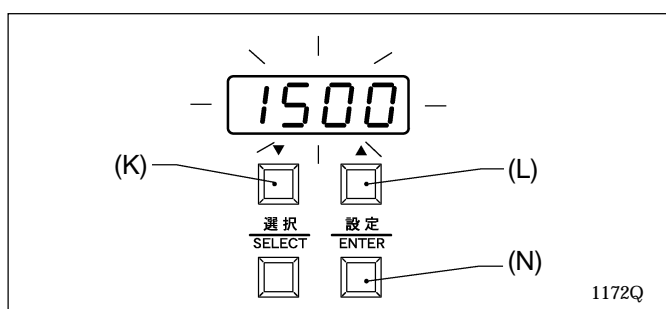

Counting down to zero method

1. Press the MODE button (1) to switch to automatic mode.
2. Press the ENTER button (N).

* The units digit will start flashing in the display.

3. Press the "Up" button (L) or the "Down" button (K) to set the value for the units column, and then press the ENTER button (N).

Repeat this step for the tens, hundreds and thousands columns.

* The production counter function can be stopped by setting counter to "0000".

* When the thousands column has been set, the machine will return to normal automatic mode.

Note: If the counting down to zero method is used, further sewing will not be possible when the production counter reaches "0", so a number greater than zero should always be set. The production counter can be returned to the initial setting value simply by pressing the ENTER button (N).

* If you would like to change the production counter setting due to sewing errors, use the counting down to zero setting procedure to set the production counter.

7-6. Using a cycle program

This example shows the procedure for a cycle program which runs program 1 (with the knife operating) three times and program 3 (with the knife not operating) once.

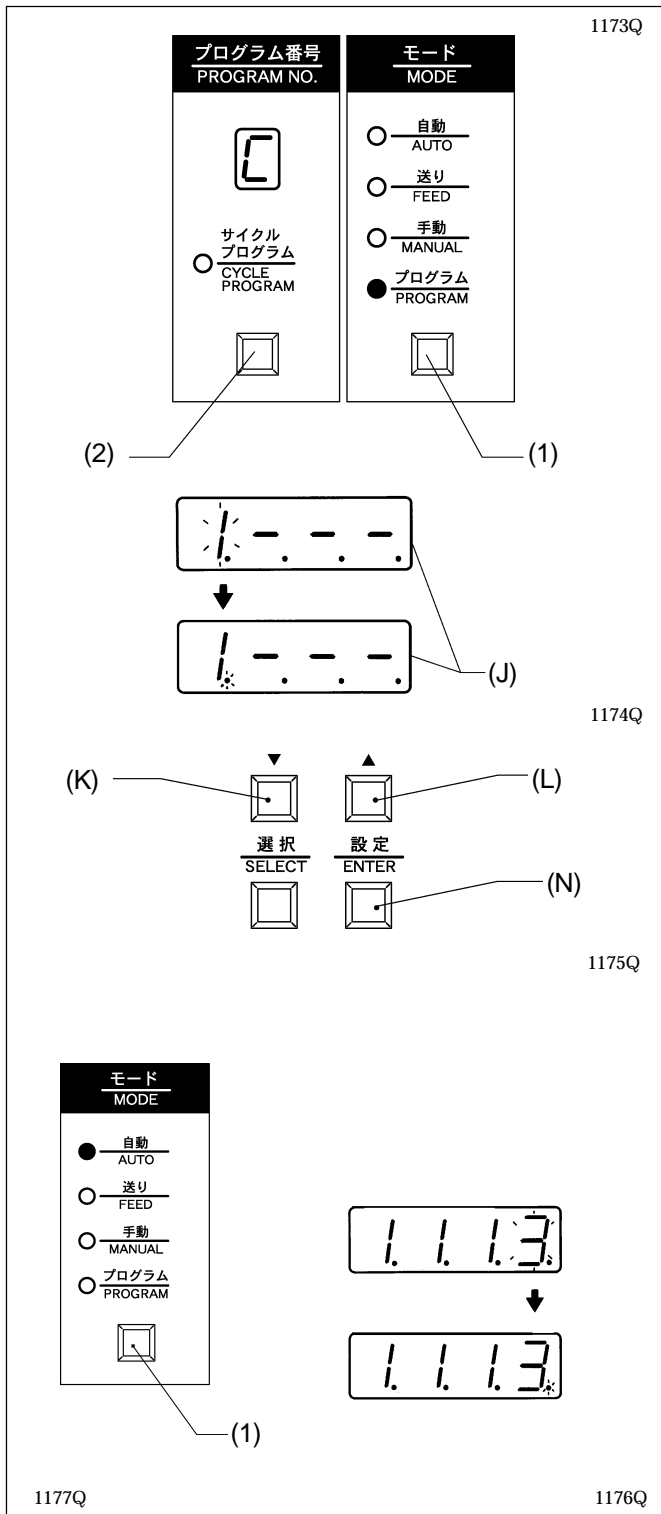

Programming procedure

- Press the MODE button (1) to switch to programming mode.
- Keep pressing the SELECT button (2) until " C " appears in the program number display window.
 - * The number in the thousands column of the front panel display (J) will start flashing at this time.
- Press the "Up" button (L) or the "Down" button (K) to change the value in the thousands column to "1", and then press the ENTER button (N).
 - * Program number 1 will now be set, and the dot in the thousands column will flash.
- Change the flashing interval so that the illumination time for the dot is longer than the switched-off time.
 - * Press the "Up" button (L) to make the illuminated period longer, and press the "Down" button (K) to make the illuminated period shorter.
- Press the ENTER button (N).
 - * The dot in the thousands column will illuminate steadily and the number in the hundreds column will start flashing.
 - * When the dot is illuminated, the knife will operate, and when the dot is switched off, the knife will not operate. However, if the OFF indicator illuminates during sewing, the knife will not operate even if the dot is illuminated.
- Repeat steps 3. to 5. for the hundreds and tens columns.
- Press the "Up" button (L) or the "Down" button (K) to change the value in the units column to "3", and then press the ENTER button (N).
 - * Program number 3 will now be set, and the dot in the units column will flash.
- Change the flashing interval so that the illumination time for the dot is shorter than the switched-off time, and then press the ENTER button (N).
 - * The dot in the units column will switch off and the number in the thousands column will start flashing.
- Press the MODE button (1) to switch to automatic mode. The cycle program "1.1.1.3" will then be set.

* If you want to clear a cycle program, carry out steps 1. and 2. above and then press the RESET button. Then press the MODE button (1) to switch to automatic mode.

7-7. Setting the feed bracket to the front position

Setting the material will be easier if the feed bracket is moved forward from the standard cloth setting position.

* Cycle time will be reduced with this setting, particularly if cutting after sewing is selected.

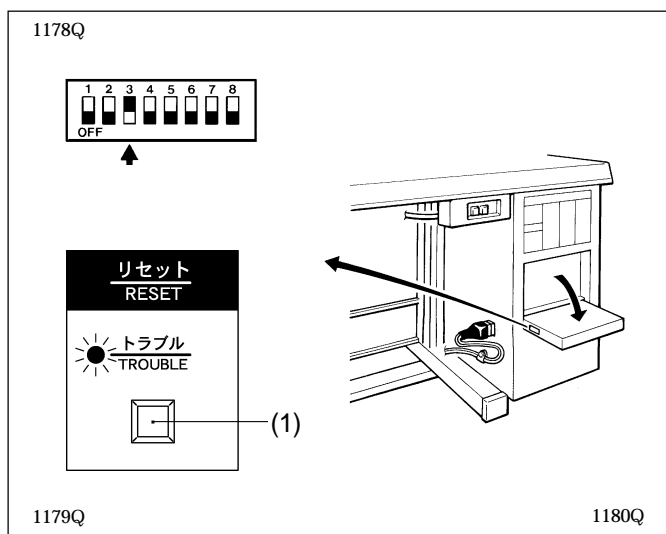

1. Turn off the power.
2. Set DIP switch No. 3 inside the front panel.
3. Turn on the power.
4. Press the RESET button (1).
5. The feed bracket will move to the front position.
6. Sewing can then be carried out as normal. (Refer to page 30.)

7-8. Switching between single-pedal and dual-pedal operation (Switching the foot controller)

The cloth presser can be lowered and the machine can start sewing just by pressing the start switch, without having to use the cloth presser switch.

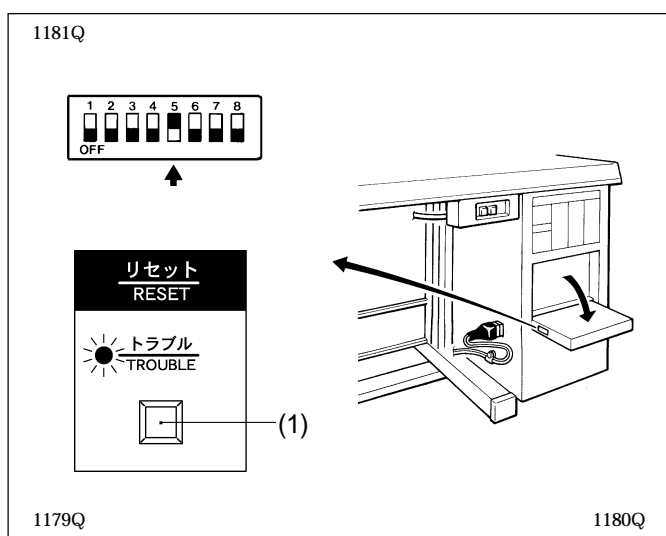

1. Turn off the power.
2. Change the setting of DIP switch No.5.
OFF: To use both pedals (cloth presser switch and start switch)
ON: To use only one pedal (start switch)
3. Turn on the power and press the RESET button (1).
Sewing can then be carried out as normal.
Note: During single pedal operation, when the start switch is pressed, the cloth presser is lowered and sewing starts straight away.

7-9. Using feed mode

In this mode, the feed bracket and the cloth presser can be moved while the needle is stopped. It is useful for checking the relative positions of the throat plate and the cloth presser.

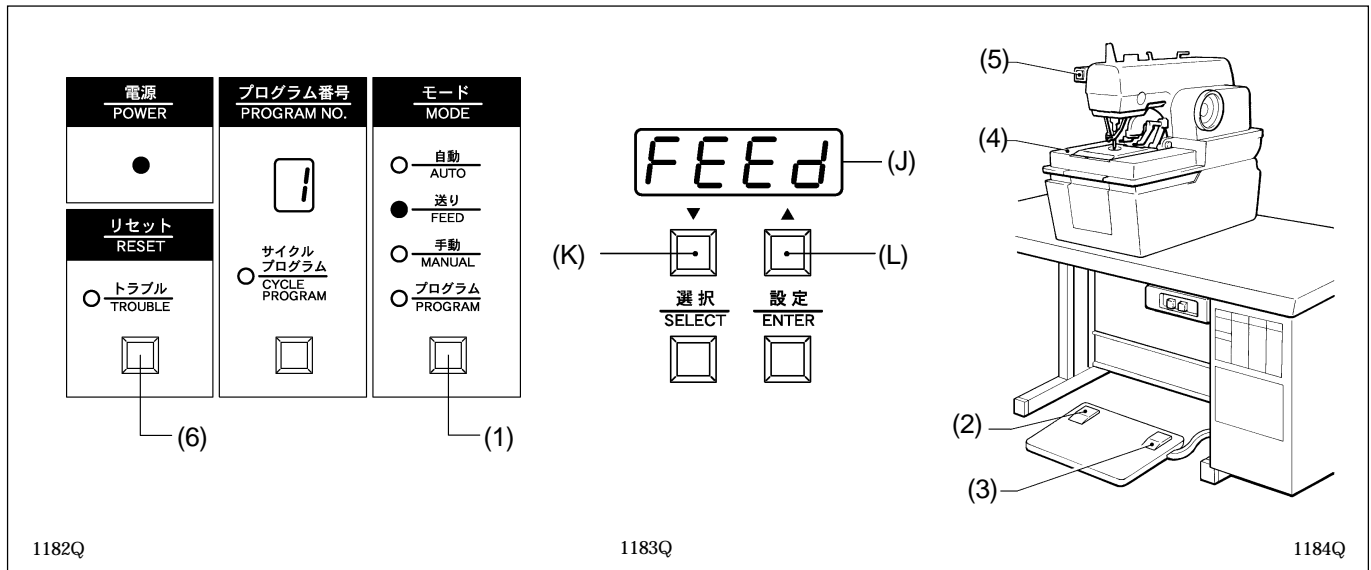

1. Press the MODE button (1) to switch to feed mode.

* "FEEd" will appear in the front panel display (J).

2. Press the cloth presser switch (2). The cloth pressers will be lowered.

3. Press the start switch (3).

The feed bracket (4) will move to the sewing start position.

* When the start switch (3) or the "Up" button (L) is pressed, the feed bracket (4) will move to the next sewing position.

* If the "Down" button (K) is pressed, the feed bracket (4) will move to the previous sewing position.

* To return the feed bracket (4) to the cloth setting position while sewing:

1) Press the EMERGENCY STOP switch (5).

2) Press the RESET button (6).

Note: The knife will not operate during this time.

7-10. Using manual mode

In this mode, the needle and the feed bracket can be moved one stitch at a time by turning the upper shaft pulley by hand.

It is useful for checking the positions of the needle and the looper after the looper timing has been adjusted.

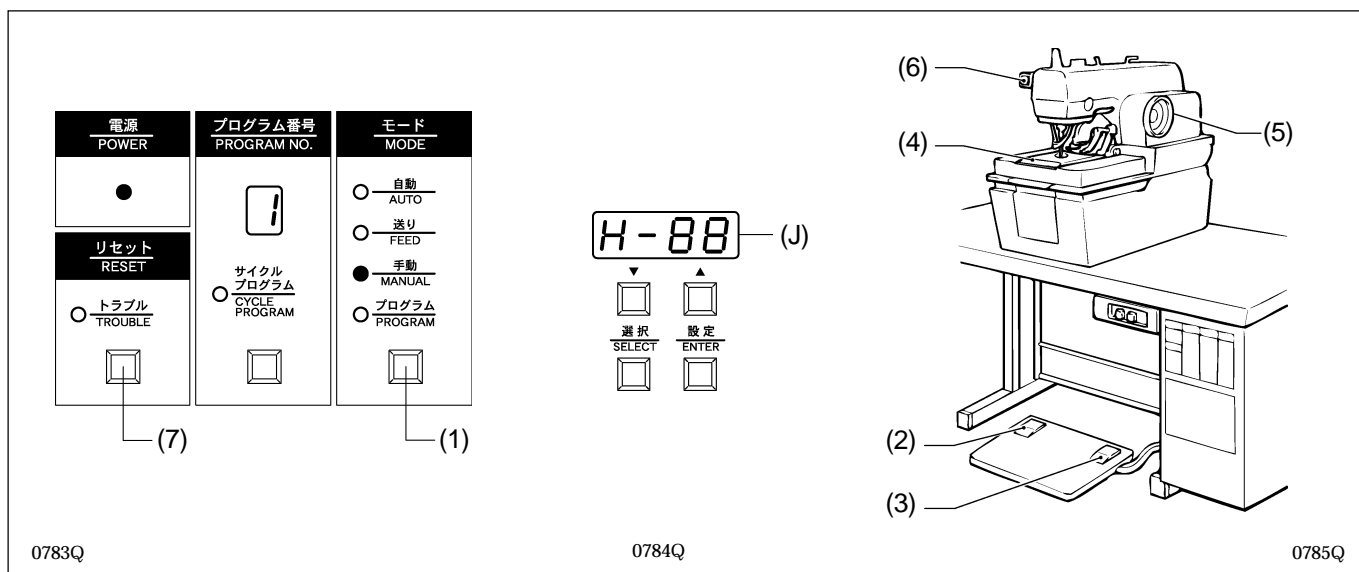

- Press the MODE button (1) to switch to manual mode.
 - * "H- □ □" will appear in the front panel display (J). (□ □ represents the number of stitches remaining.)
- Press the cloth presser switch (2). The cloth presser will be lowered.
- Press the start switch (3).
 - * The knife will operate only when cutting before sewing has been set.
 - * The feed bracket (4) will move to the sewing start position.
- Turn the upper shaft pulley (5) toward you.

The feed bracket (4) will move to the next sewing position in accordance with the rotation of the upper shaft.

Note: If the upper shaft pulley (5) is turned in the wrong direction, the feed bracket timing may become disrupted.

 - * To return the feed bracket (4) to the cloth setting position while sewing:
 - Press the EMERGENCY STOP switch (6).
 - Press the RESET button (7). The feed bracket (4) will then return to the cloth setting position.
- Turn the upper shaft pulley (5) until the last stitch has been sewn. The buzzer will then sound.

Note: Check that the mark on the upper shaft pulley (5) is aligned with the notch in the pulley cover.
- Press the start switch (3).
 - * The movement of the feed bracket (4), lower thread trimming and operation of the cloth presser will all be carried out as a single step.
 - * The knife will operate only when cutting after sewing has been selected.

7-11. Changing the cycle program counter

The cycle program counter can be easily changed if necessary, for instance because re-sewing was necessary.

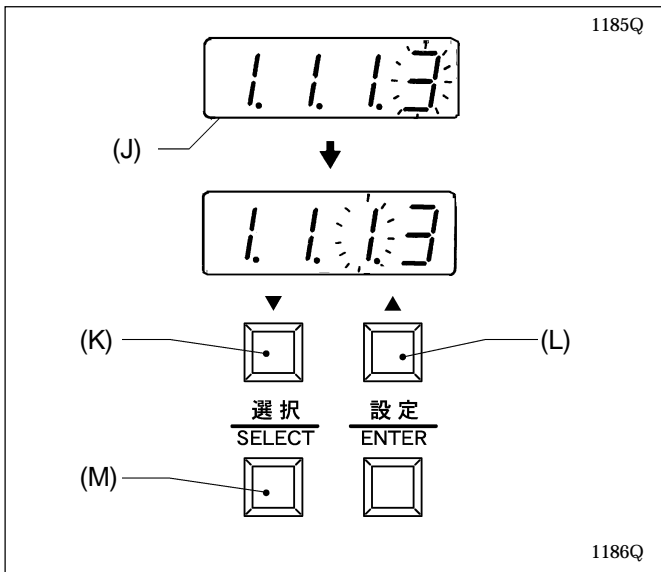

1. If carrying out cycle sewing in AUTO mode, switch the contents shown in the front panel display from the production counter to the cycle program.

The program number which is to be sewn next will flash in the display. To change the cycle program counter (the position where the display is flashing), press the "up" button (L) or the "down" button (K) to make the desired setting.

* If you would like to switch the display from the cycle program to the production counter, press the SELECT button (M). The production counter will be displayed while this switch is being pressed.

7-12. Setting the number of home position cycles

The number of home position cycles can be set in order to shorten the overall cycle time.

* This function is only valid when DIP switch No. 8 on the circuit board is set to ON.

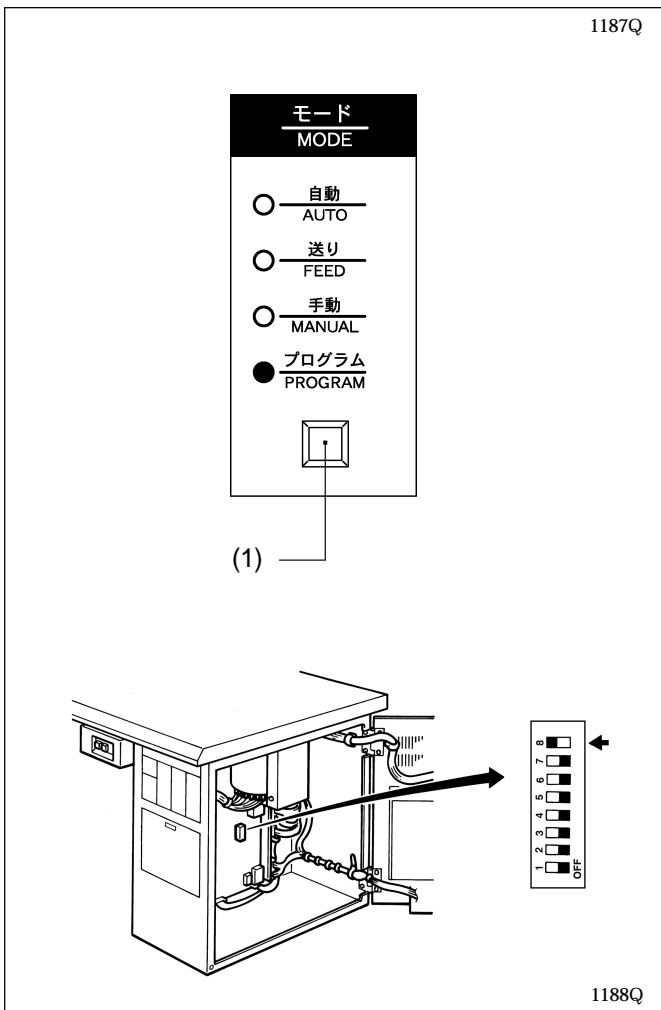

1. Press the MODE button (1) to switch to program mode.
2. Press the SELECT button (M) so that "HP" is displayed in the front panel display.

* The display will change in the following order each time the SELECT button is pressed:

→A → B P4 → HP →

(Continued on next page)

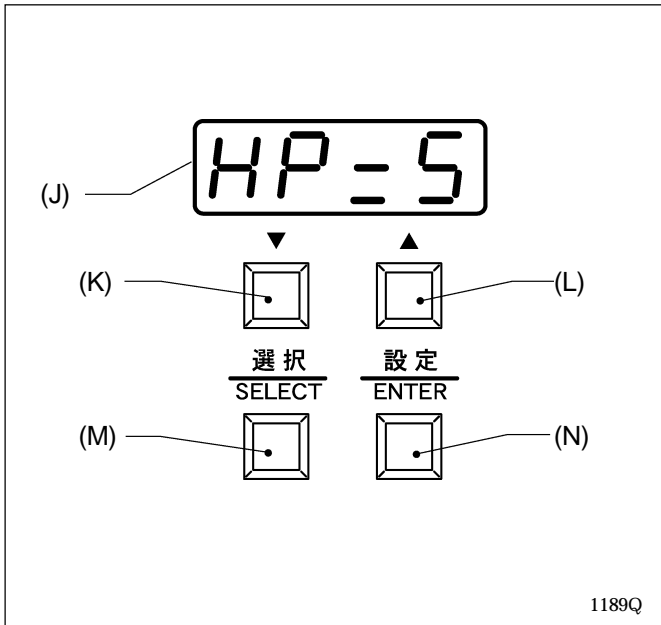

- Press the "up" button (L) or the "down" button (K) until the desired number of home position cycles is displayed.

The setting range is between 0 and 9.

* If the number of home position cycles is set to "5", returning to the home position will occur once for every five cycles.

However, when carrying out cycle sewing, the machine will return to the home position once for each cycle program regardless of the number of home position cycles which have been set (unless the setting is "0").

Normal home position cycling will not be carried out if the setting is "0".

- Press the ENTER button (N) to accept the home position cycle setting. This setting will apply to all program numbers from 1 to 9.

* The display will stop flashing and will start illuminating steadily.

Note: If for some reason an excessive load is applied to the feed bracket which causes it to slip, then there is the danger that this will have an adverse effect on subsequent sewing operations. Therefore, it is recommended that you return to the home position for each cycle (i.e. that you leave DIP switch No. 8 on the circuit board set to OFF).

7-13. Returning to the home position

This is useful for correction purposes when mistiming occurs in the home position cycle because re-sewing was carried out.

* This function is only valid when DIP switch No. 8 on the circuit board is set to ON.

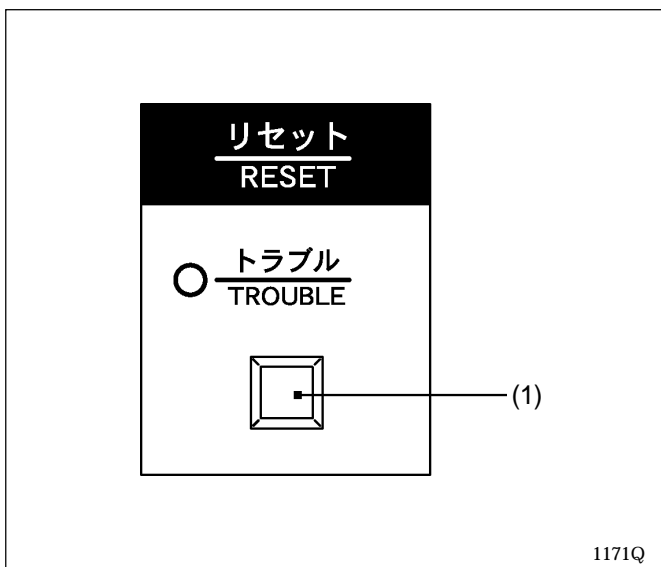

- When at the home position in AUTO mode, press the RESET button (1) to start sewing from the home position.

8. CLEANING AND MAINTENANCE

⚠ CAUTION



Turn off the power switch before starting any cleaning work, otherwise the machine may operate if the start switch is pressed by mistake, which could result in injury.



Be sure to wear protective goggles and gloves when handling the lubricating oil and grease, so that they do not get into your eyes or onto your skin, otherwise inflammation can result.

Furthermore, do not drink the oil or eat the grease under any circumstances, as they can cause vomiting and diarrhoea.

Keep the oil out of the reach of children.

8-1. Cleaning

If using an air gun, do not use it while the machine head is tilted back, otherwise oil and thread scraps may adhere to the cutter sensor and timing belt, resulting in operating problems.

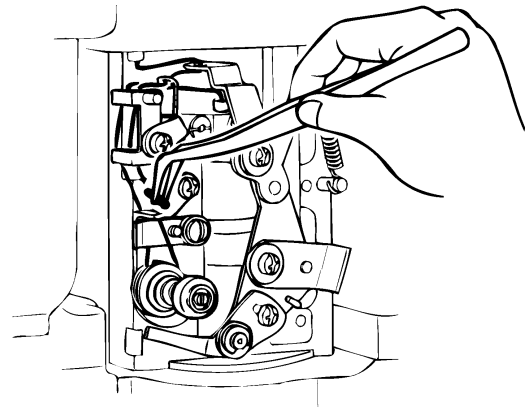
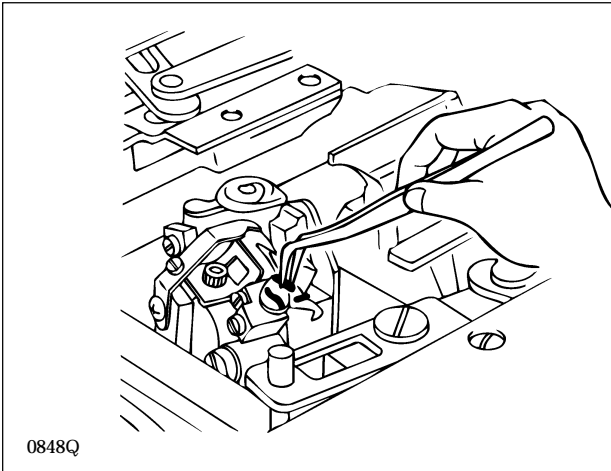

1. Turn off the power.
2. Turn the air cock to stop the air.
* Turn the knob to release the air.
3. Remove any thread scraps and dust, etc. from the thread paths for the needle thread, looper thread and gimp.
In particular, the looper thread path should be cleaned every day to keep it free from thread scraps and dust.
4. Check the oil level by looking at the sight glass. If the oil level is low, replenish the oil supply.
5. Remove and discard any oil that has collected in the oil container.
6. Check the air filter and remove any water that has collected in the drain.
(Refer to the illustration below.)

8-2. Draining the oil

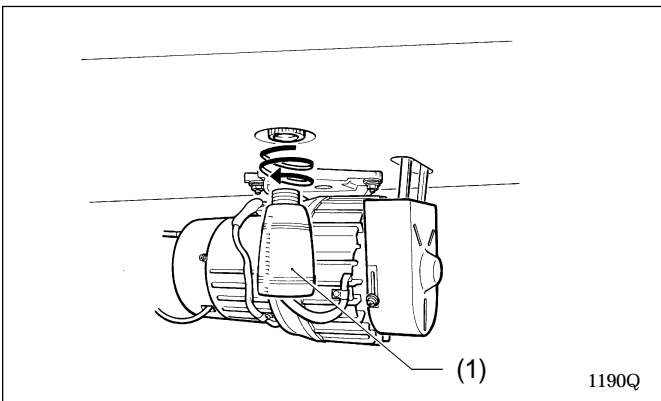

1. When the oil container (1) is full of oil, remove the oil container (1) and let the oil drain out.
Note: Clean up any oil that may have been spilled onto the floor.

8-3. Checking the air filter

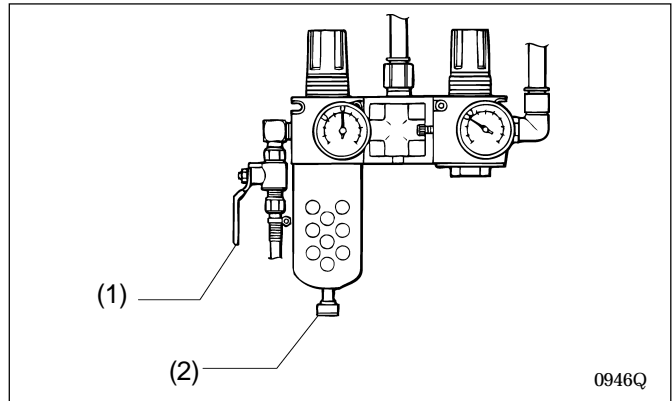

1. Close the air cock (1).
2. Turn the screw (2) to release any air and water in the drain.

9. STANDARD ADJUSTMENTS

⚠ CAUTION



Maintenance and inspection of the sewing machine should only be carried out by a qualified technician.



Ask your Brother dealer or a qualified electrician to carry out any maintenance and inspection of the electrical system.



Turn off the power switch and disconnect the power cord from the wall outlet at the following times, otherwise the machine may operate if the start switch is pressed by mistake, which could result in injury.

- When carrying out inspection, adjustment and maintenance.
- When replacing consumable parts such as the loopers and knife.



Disconnect the air hoses from the air supply and wait for the needle on the pressure gauge to drop to "0" before carrying out inspection, adjustment and repair of any parts which use the pneumatic equipment.



If the power switch and air need to be left on when carrying out some adjustment, be extremely careful to observe all safety precautions.



If any safety devices have been removed, be absolutely sure to re-install them to their original positions and check that they operate correctly before using the machine.

9-1. Adjusting the height of the spreader and looper

Spreader height

The clearance between the left spreader (forked spreader) and the left looper must be set to match the thickness of the lower thread. The clearance between the right spreader and the right looper should be as small as possible while still letting the parts slide.

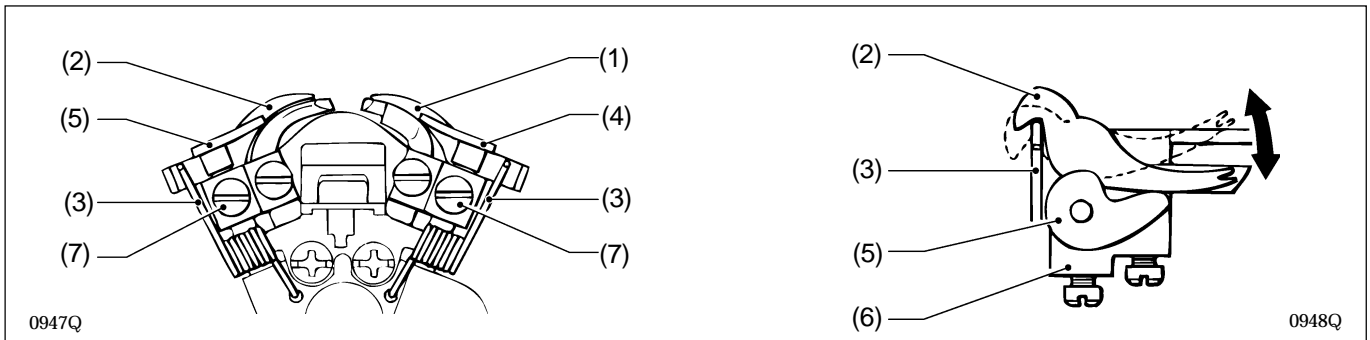

1. The right spreader (1) and left spreader (2) move by means of springs (3). Adjust so that the spreaders move smoothly between the right spreader stopper (4), the left spreader stopper (5) and the LS-holder bracket (6), with no looseness.
2. If adjustment is necessary, loosen the screw (7) and then move the right spreader stopper (4) or left spreader stopper (5) up or down.

Looper height

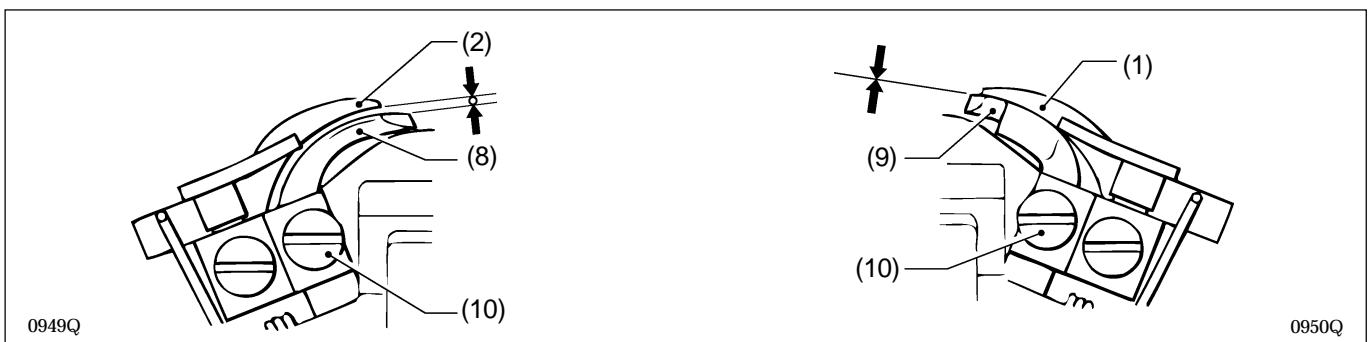

1. Set the clearance between the left looper (8) and the left spreader (2) to the same distance as the thickness of the lower (looper) thread.
2. The clearance between the right looper (9) and the right spreader (1) should be as small as possible.
3. If adjustment is necessary, loosen the screw (10) and then move the left looper (8) and right looper (9) up or down.

9-2. Adjusting the needle and looper timing

The distance by which the needle bar rises from its lowest position to the position where the tip of the left looper and the center of the needle are aligned should be the same as the distance from its lowest position to the position where the tip of the right looper and the center of the needle are aligned.

Before adjusting the looper timing, first adjust the stitch width (needle racking width).

* Refer to "Adjusting the needle racking width (stitch width)" on page 48. The standard width is 3 mm.

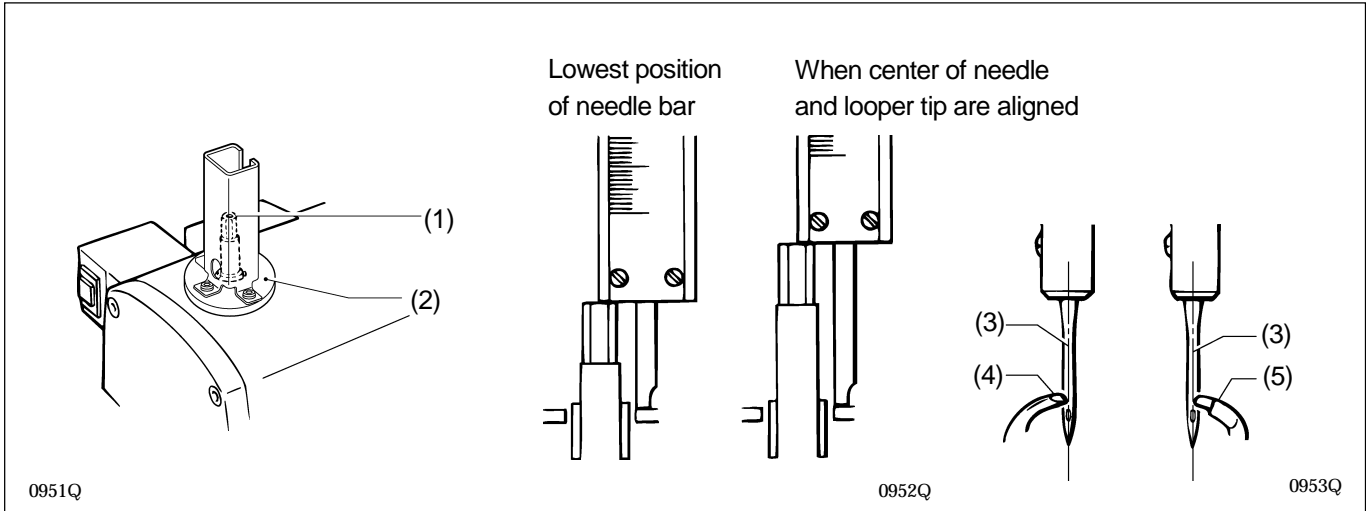

1. Move the needle bar to its lowest position.
2. Use calipers to measure the distance between the end of the needle bar (1) and the top of the needle bar bracket (2) when the needle bar is at its lowest position.
3. Turn the upper shaft pulley until the tip of the left looper (4) and the center of the needle (3) are aligned when the needle (3) is at the inside sewing position, and then use the calipers to take the same measurement as taken in step 2. Find the difference between the measurements taken in this step and in step 2.
4. Follow the same procedure as in step 3. above to find the difference between the two measurements when the needle (3) is at the outside sewing position.

* When the needle (3) is at the inside sewing position, the tip of the left looper (4) should be aligned with the center of the needle (3), and when the needle (3) is at the outside sewing position, the tip of the right looper (5) should be aligned with the center of the needle (3).

* The distance from the end of the needle bar (1) and the top of the needle bar bracket (2) should be the same when the needle (3) is at both the inside sewing position and the outside sewing position.

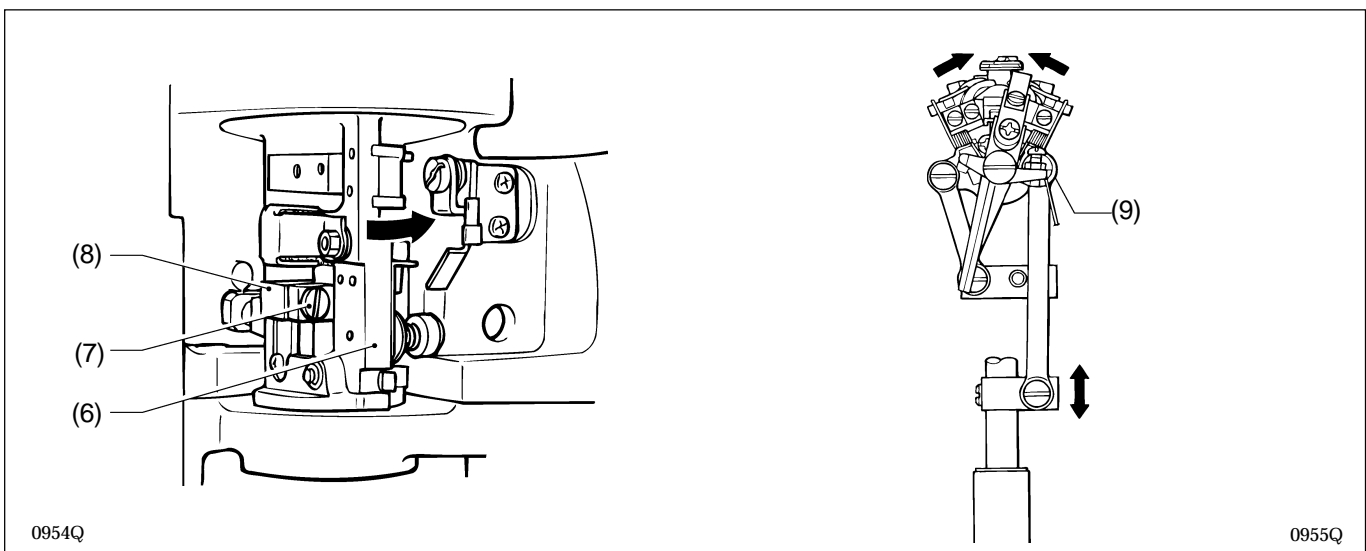

5. If adjustment is necessary, turn the race stand (6) in the direction indicated by the arrow in the illustration, loosen the screw (7), and then move the looper link support (8) up or down to tilt the LS-holder bracket (9) to the left or right (in the direction of the arrow).

9-3. Adjusting the loop stroke

The loop stroke is the distance the needle bar rises from its lowest position to the position where the tips of the left and right loopers are aligned with the center of the needle. The standard loop stroke is 2.7 mm. (The loop stroke may need changing depending on the material and thread being used.)

* Carry out the adjustment in "9-2. Adjusting the needle and looper timing" before making this adjustment.

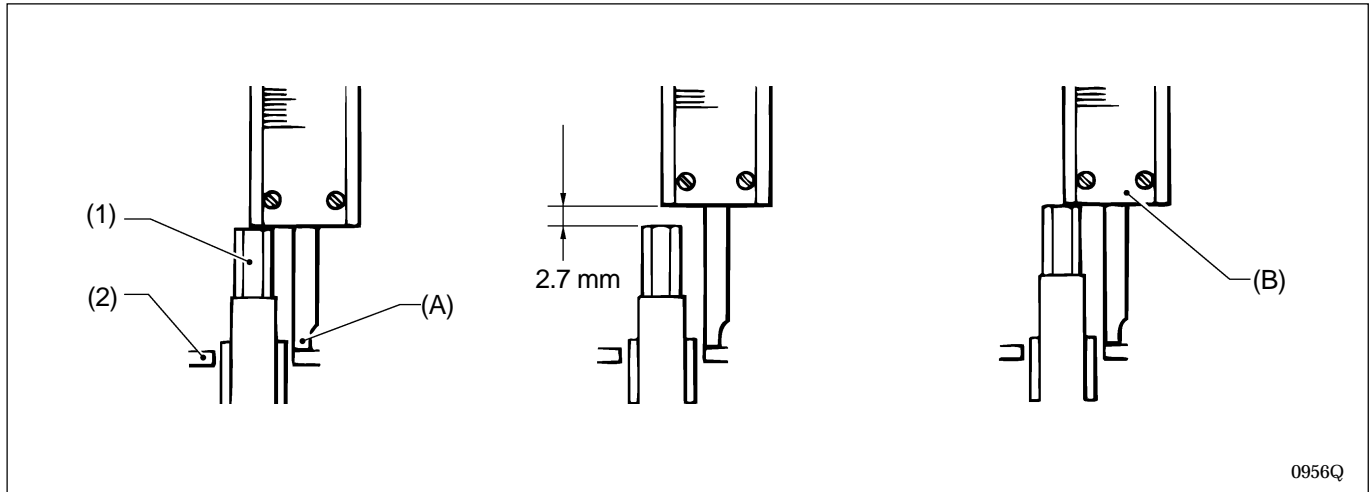

1. In the same way as in "9-2. Adjusting the needle and looper timing", move the needle bar to its lowest position with the needle at the inside sewing position, and then use calipers to measure the distance between the end of the needle bar (1) and the top of the needle bar bracket (2).
2. Add 2.7 mm to the value obtained in step 1. above.
3. Touch the end of the calipers (A) against the top of needle bar bracket (2), and then turn the upper shaft pulley until the end of the needle bar (1) touches the edge of the calipers (B). Check that the tip of the left looper is aligned with the center of the needle at this time.
4. In the same way, check that the tip of the right looper is aligned with the center of the needle when the needle is at the outside sewing position.

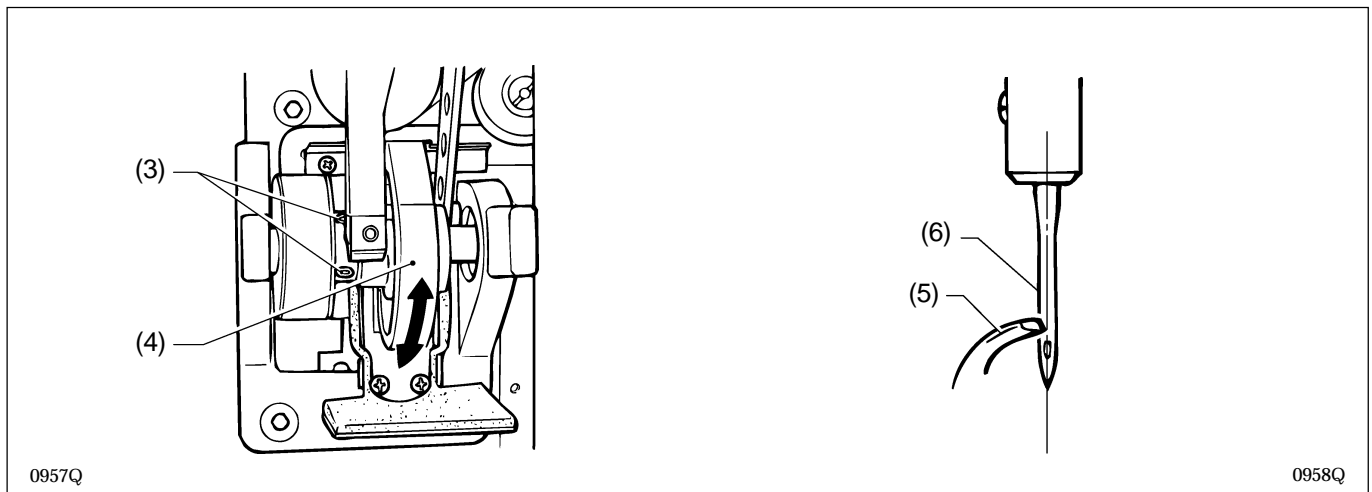

5. If the tips of the loopers are not aligned with the center of the needle, carry out the adjustment below.
 Raise the machine head.
 Loosen the two screws (3) of the lower shaft timing pulley, hold the upper shaft pulley so that it doesn't move, and then turn the lower shaft cam (4) in the direction indicated by the arrow until the tip of the left looper (5) is aligned with the center of the needle (6). Once they are aligned, tighten the two screws (3).
 After adjusting, check that the screws have been adequately tightened.
 Once this adjustment has been carried out, repeat the procedure given in "9-2. Adjusting the needle and looper timing".

9-4. Adjusting the height of the needle bar

The standard height for the needle bar is 2.5 mm. (The needle bar height may need changing depending on the material and thread being used.)

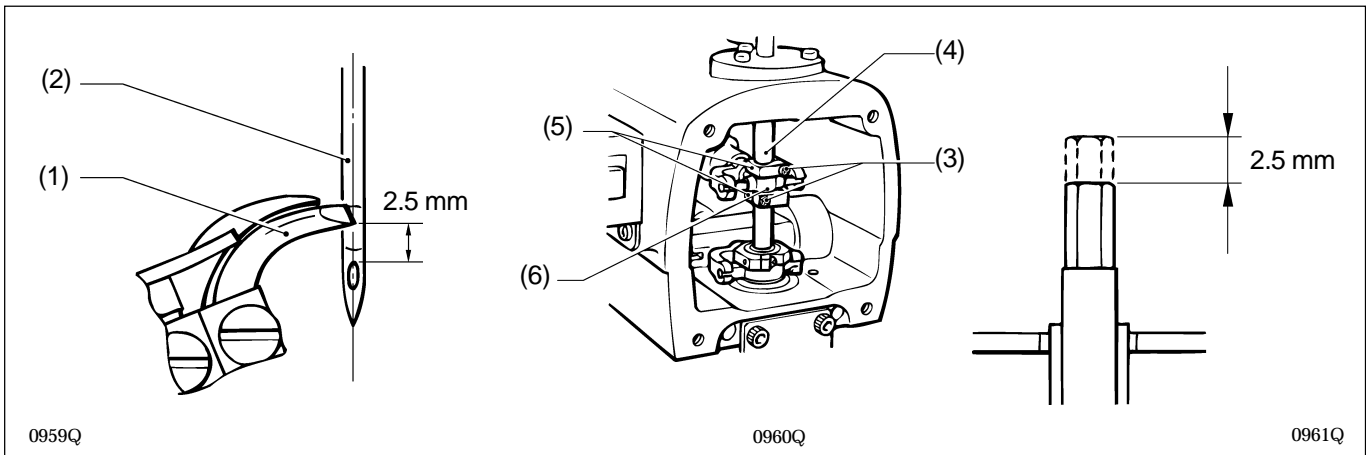

1. Align the tip of the left looper (1) with the center of the needle (2) when the needle (2) is at the inside sewing position.
2. Remove the face plate.
3. Loosen the screw (3) of the needle bar clamp (5) and adjust the height of the needle bar (4).
 - * After aligning the tip of the left looper (1) with the top edge of the needle hole, lower the needle bar (4) 2.5 mm.
4. Adjust so that there is as little play as possible, and so that the needle bar clamp (5) and the needle bar horizontal link (6) can maintain their oil films. This will help to ensure that the needle bar turns smoothly.

9-5. Adjusting the clearance between the looper and needle

Be sure to carry out this adjustment after changing the size of the needle.

The clearance between the tip of the looper and the needle should be 0.05 - 0.2 mm.

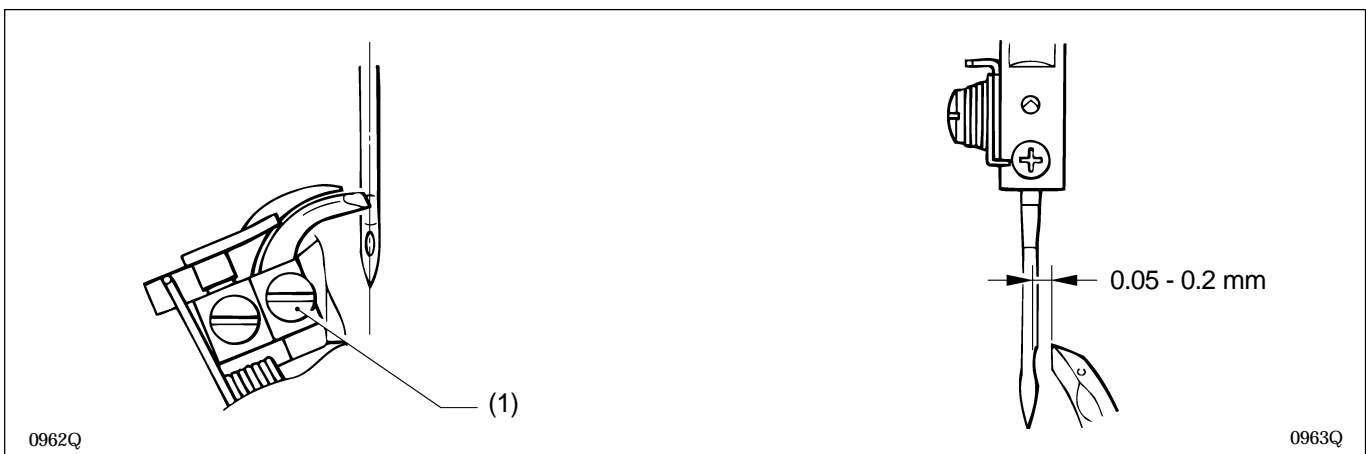

1. Loosen the looper screw (1) and then adjust the clearance.
 - * This clearance must be uniform while the race stand is rotating (through 360°).
If the clearance is not uniform, adjust the turning center for the needle bar. (This adjustment is made at the time of shipment from the factory.)
 - * After making the adjustment in step 1. above, carry out the adjustment procedure given in "9-7. Adjusting the spreader mounting positions".

9-6. Adjusting the needle guard

Be sure to carry out this adjustment after changing the size of the needle.

The needle must remain stationary with respect to the needle guard until the tip of the looper reaches the needle.

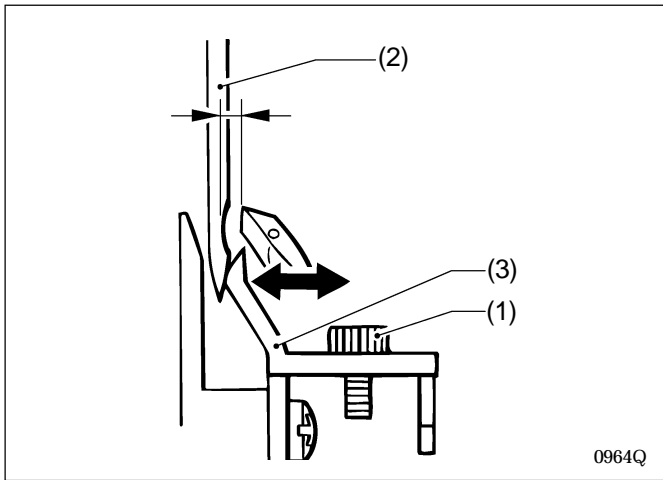

1. Loosen the screw (1) and then move the needle guard (3) in the directions indicated by the arrows by an appropriate amount in accordance with the thickness of the needle (2).

Note: Adjust so that the looper clasps the upper thread securely.

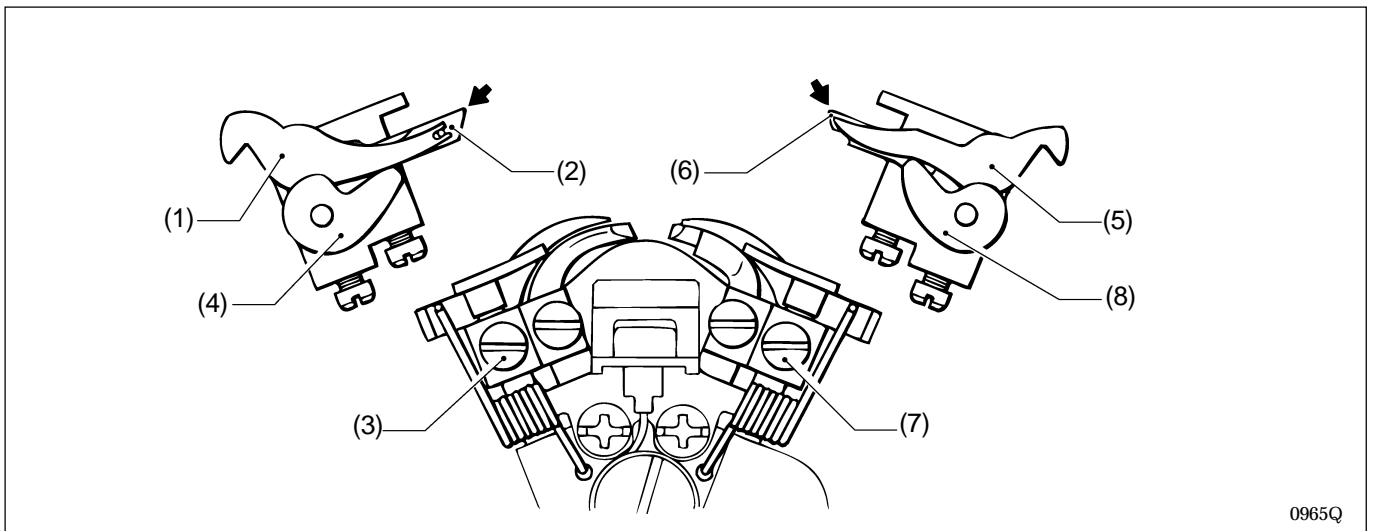

9-7. Adjusting the spreader mounting positions

1. Loosen the screw (3) and adjust the position of the left spreader stopper (4) so that the fork of the left spreader (1) is aligned with the lower thread guide hole of the left looper (2).
2. Loosen the screw (7) and adjust the position of the right spreader stopper (8) so that the tip of the right spreader (5) is aligned with the tip of the right looper (6).

Note: Both the left spreader (1) and right spreader (5) should be installed so that they do not project past the tips of the left looper (2) and right looper (6) respectively.

9-8. Adjusting the spreader timing

When the needle is at the inside sewing position, the left spreader should touch the left spreader stopper and stop immediately before the needle bar reaches its lowest position.

When the needle is at the outside sewing position, the right stopper should touch the right spreader stopper and stop immediately before the needle bar reaches its lowest position.

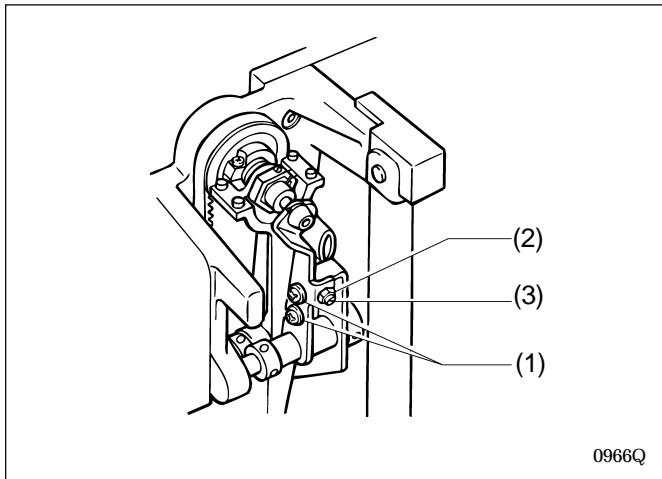

1. Raise the machine head.
2. Loosen the screw (1) and the nut (2), and then turn the adjusting screw (3) to adjust the spreader timing.
3. After adjusting, tighten the nut (2) and the screw (1).

9-9. Adjusting the needle racking width (stitch width)

The needle racking width is set to 3 mm at the time of shipment from the factory.

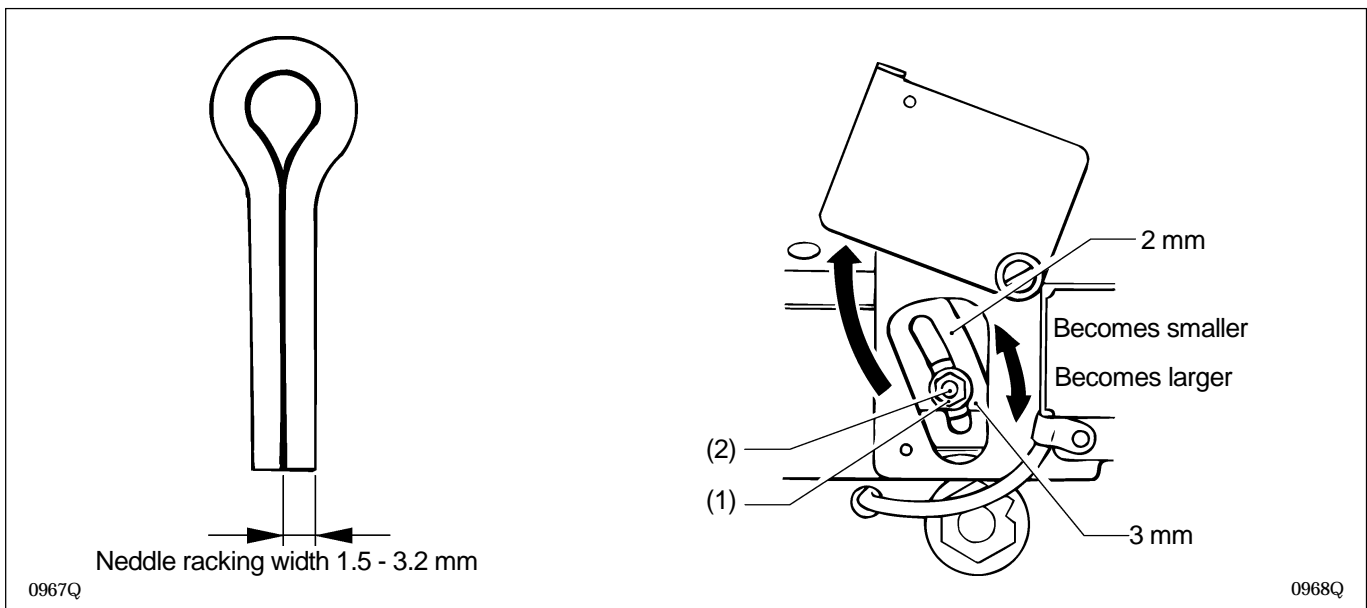

1. Loosen the needle racking adjustment nut (1) and then adjust the needle racking width by sliding the adjustment screw (2) vertically along the oval slot.

The stitch width becomes smaller as the adjustment screw (2) is moved upward.

Note: If the needle racking width is changed greatly, you should re-adjust the timing between the needle and the loopers.

(Refer to "9-2. Adjusting the needle and looper timing".)

9-10. Changing the knife cutting length (Replacing the cutting block)

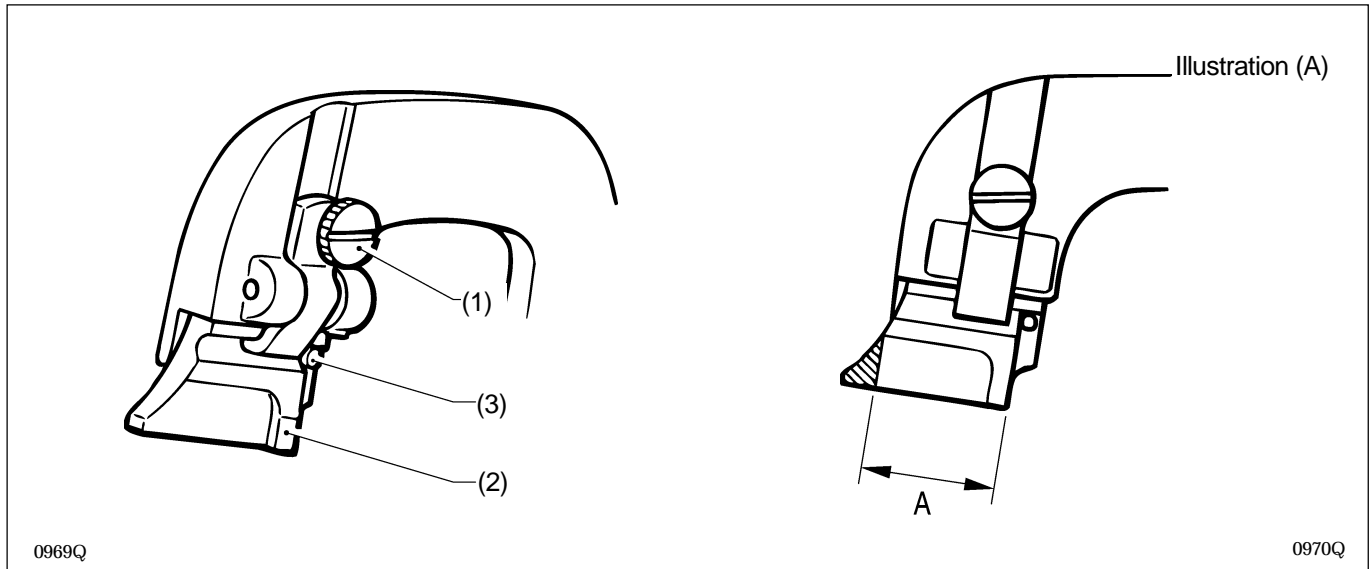

1. Grind or replace the cutting block after changing the knife cutting length.
 - * When replacing the cutting block with a new one, be sure to adjust the contact between the knife and the cutting block. (Refer to the next page.)
2. Loosen the screw (1), and then remove the cutting block (2).

Because the knife cutting length is set in accordance with the length of the cutting block, grind the cutting block as shown in (A) in the above illustration.

Cutting block length $A = \text{Knife cutting length} + 1.5 \text{ mm}$
3. When installing the cutting block, push in the pin (3) and then tighten the screw (1).
 - * Do not use knives with different numbers on the same cutting block. If knives with different numbers are used, accurate cutting will not be possible and the knife will be damaged.

Changing in the cutting block operation time.

If cutting is not possible even when the air pressure is increased to 0.3 MPa, memory switch No. 18 can be used to increase the cutting block ON time. (Refer to "6-6. Using the memory switch".)

9-11. Adjusting the contact between the knife and the cutting block

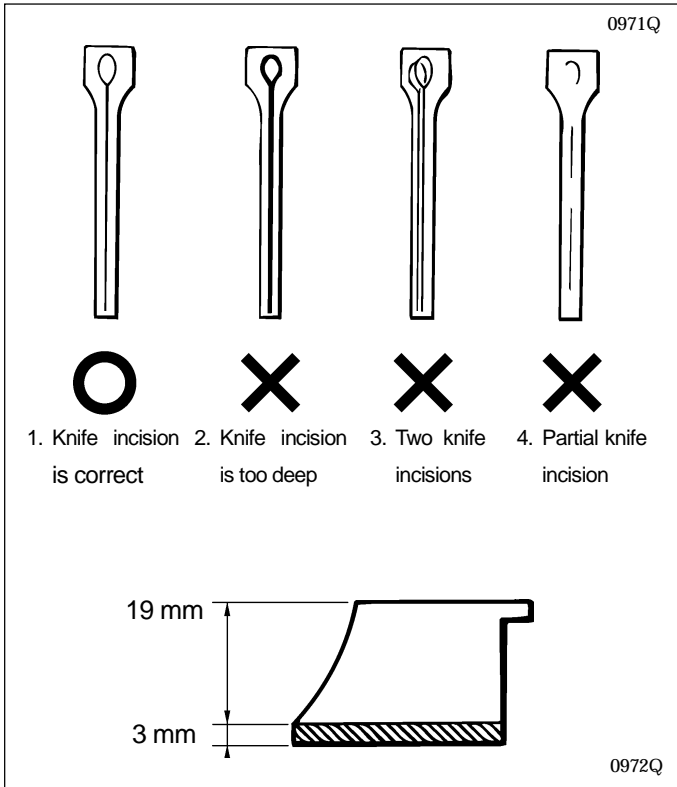

1. Remove the cutting block. (Refer to the previous page.)
2. If the knife incision on the surface of the cutting block is very deep, if there are two or more incisions on the cutting block because different knives were used, or if only part of the incision has been made, grind the surface of the cutting block smoothly until a single knife incision can still be seen faintly.
3. The cutting pressure over the whole of the cutting block should be uniform so that the material will be cut cleanly. Grind the surface of the cutting block so that the knife incision will be uniform over the whole of the cutting block.
 - * The cutting block can be filed until its height is 19 mm.
4. If the material cannot be cut cleanly even though the cutting block has been ground correctly, check whether the tip of the knife is worn.
 - * If the tip is worn, replace the knife. Do not use the old cutting block after the knife has been replaced, otherwise it may damage the tip of the knife.

Adjusting the contact between the knife and the cutting block

To see the knife incision more easily, color the cutting surface of the cutting block with a marker pen.

1. Operate the cutting block three times with the knife making a mark on it each time.
2. Adjust the position of the cutting block or contact between the knife and the cutting block until the knife consistently makes a mark in the same place.

Filing the cutting surface of the cutting block

Use a flat file for filing.

1. Filing the cutting surface of the cutting block on which the knife incision breaks off or is shifted
 - 1-1. Grip the cutting block in a vise.
 - 1-2. File the surface of the cutting block smoothly until the knife incision is erased away.
2. Filing the cutting surface of the cutting block in which knife incision is deep
 - 2-1. Grip the cutting block in a vise.
 - 2-2. File the surface of the cutting block smoothly until a single knife incision can still be seen faintly.

9-12. Replacing the knife

When replacing the knife with a new one, file the surface of the cutting block until smooth and until the knife does not leave a mark on the cutting block.

Before replacing the knife, be sure to check that there is no gap between the knife (1) and the knife stopper (2).

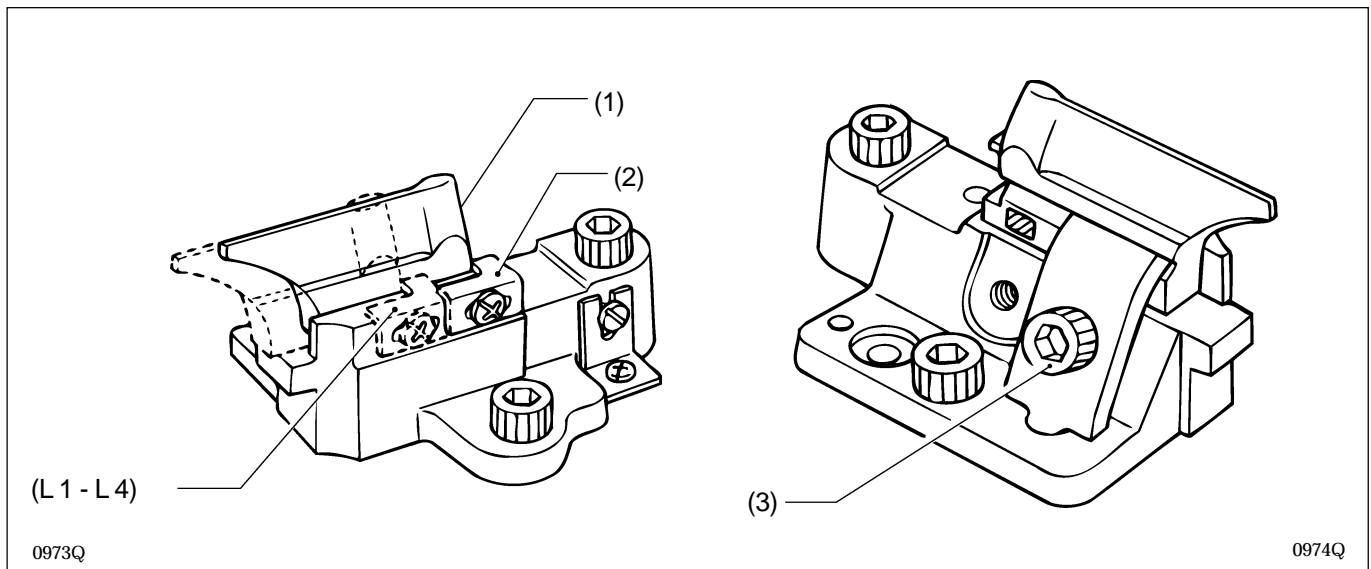

1. Loosen the screw (3), and then remove the knife (1).
2. Insert the new knife (1) into the knife stopper (2), and then tighten it with the screw (3).
3. Adjusting the contact between the knife and cutting block. (Refer to the previous page.)

Note: For L1 - L4 specifications, secure the knife stopper (2) in the position closest to you (the position indicated by the dotted lines).

* When replacing the knife (1), make sure that the knife number matches the number for the eyelet shape.

Replace the knife and cutting block as a set.

If knives with different numbers are used on the same cutting block, accurate cutting will not be possible, and damage to the knife may result.

9-13. Adjusting the cutting pressure

Adjust the cutting pressure to the minimum pressure that still allows the material to be cut.

* If the knife cutting length is 20 mm, sufficient cutting performance can be obtained with an air pressure of 0.2 MPa.

To adjust the cutting pressure, adjust the air pressure of the knife pressure adjustment regulator (1) which is mounted underneath the work table.

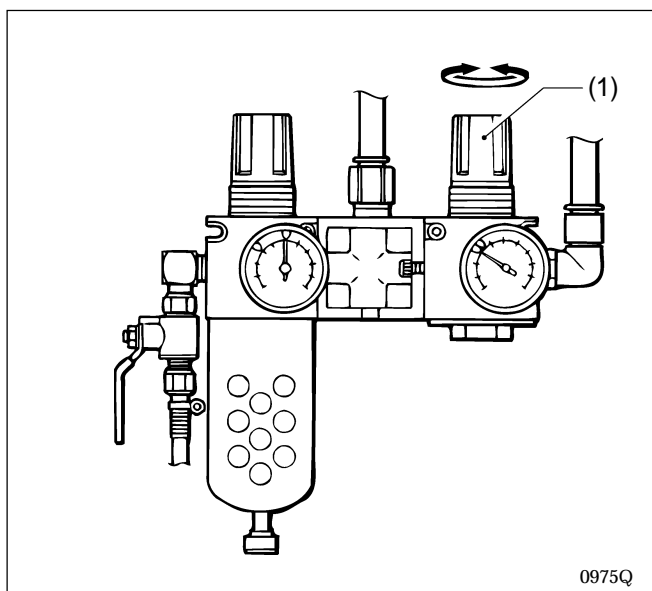

* If the cutting pressure is increased to more than is necessary, it will cause the cutting block to become worn or the knife to become damaged.

* If the material cannot be cut cleanly, do not increase the cutting pressure over the maximum limit. Check the contact between the knife and the cutting block, while referring to "9-11. Adjusting the contact between the knife and the cutting block".

9-14. Adjusting the cloth opening amount

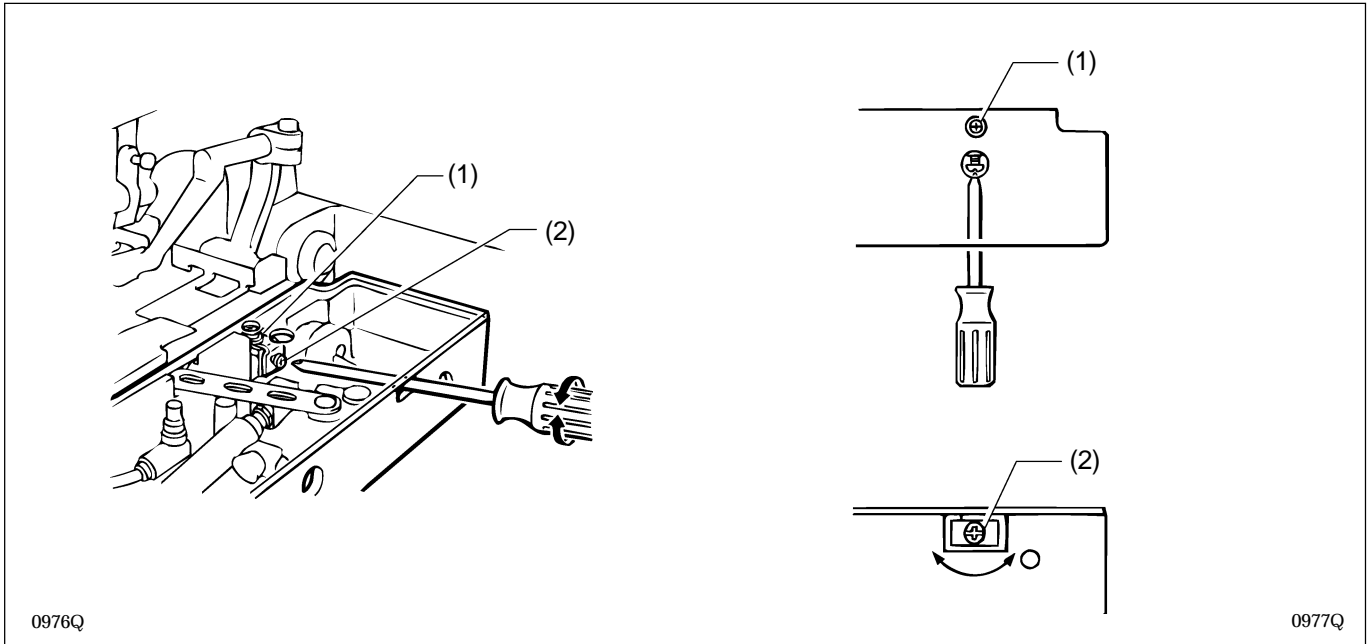

1. Loosen the screw (1), and then insert a screwdriver into the notch in the side of the feed bracket and turn the adjusting screw (2) to adjust the opening amount.
 2. After tightening the screw (1), measure the opening amount.
- Note: Adjust so that the opening amounts for the left and right cloth presser plates are equal.
- * It is usually sufficient for one cloth presser plate to open by 0.8 mm.

Measuring the opening amount

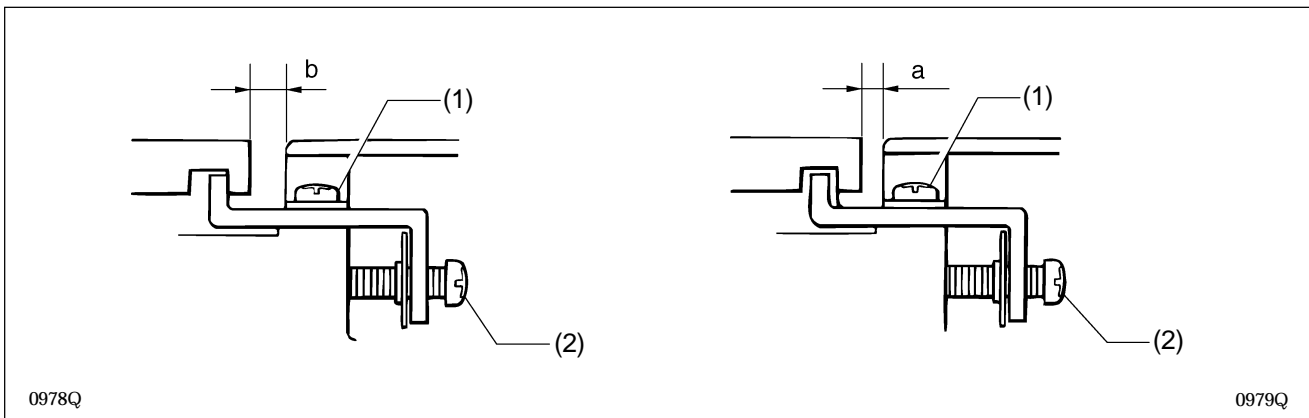

1. Switch the mode to feed mode. (Refer to page 20.)
2. Lower the cloth presser and then use calipers to measure the distance a.
3. Press the start switch. The feed bracket will move and then the left and right cloth presser plates will open.
4. Use calipers to measure the distance b.
5. The difference between a and b is the opening amount. (Opening amount = a - b)

9-15. Adjusting the trimming of the upper thread

The upper thread should be trimmed at the correct time after sewing is completed.

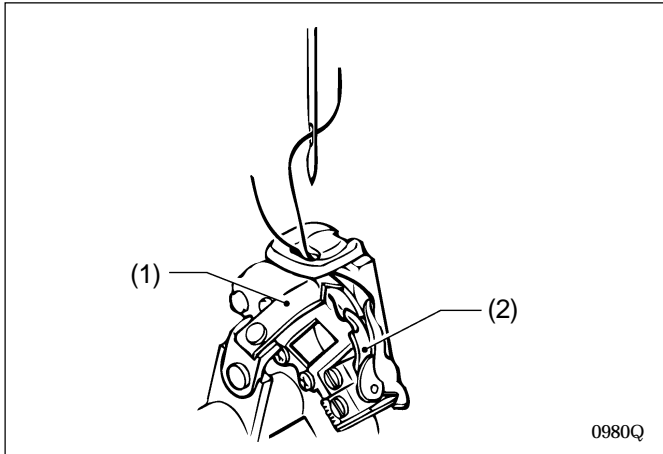

<-00, -01>

1. Adjust so that the upper thread trimmer knife (1) cuts only one of the threads in front of the right looper (2).

Note: If both strands of the thread loop are cut, the thread remaining in the needle may become too short and skipped stitches may result.

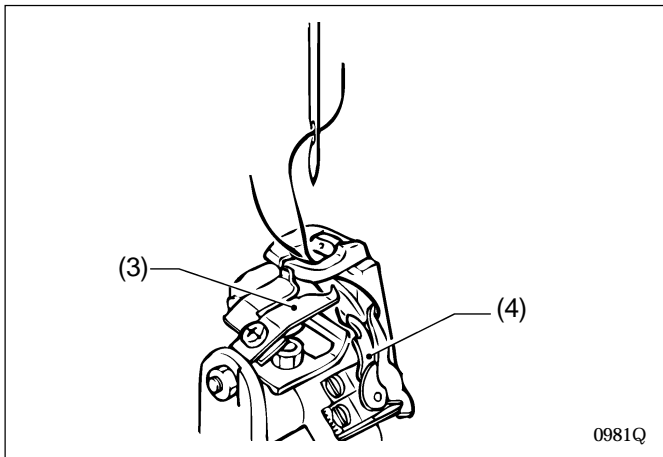

<-02>

1. Adjust so that the upper thread trimmer knife (3) cut only one of the threads in front of the right looper (4).

Note: If both strands of the thread loop (forward and back) are cut, the thread remaining in the needle may become too short and skipped stitches may result.

9-16. Adjusting the trimming of the lower thread and gimp

<-00, -01>

The lower thread and gimp should be trimmed at the correct time after the feed bracket has returned to the home position. Thread trimming operation can be checked in steps while manual mode is active. (Refer to "Using manual mode" on page 39.)

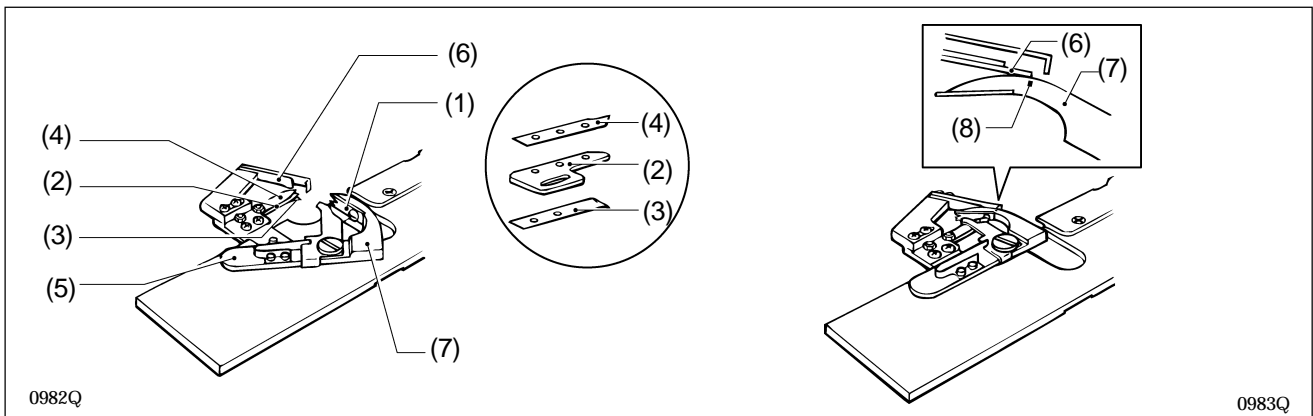

1. The mechanism is adjusted so that the lower thread and gimp are separated from each other and spread by the loop spreader (1).
2. The lower thread is held between thread nipper M (2) and thread nipper D (3) on the plate spring. The gimp is held between thread nipper M (2) and thread nipper U (4) on the plate spring.
3. Adjust so that the edge of the fixed knife (6) and the index mark (8) on the movable knife (7) are aligned when the thread trimmer knife arm (5) is at the maximum stroke.

9. STANDARD ADJUSTMENTS

<-02>

The lower thread and gimp should be trimmed at the correct time after the cloth pressers rise at the feed home position. Thread trimming operation can be checked in steps while manual mode is active. (Refer to "Using manual mode" on page 39.)

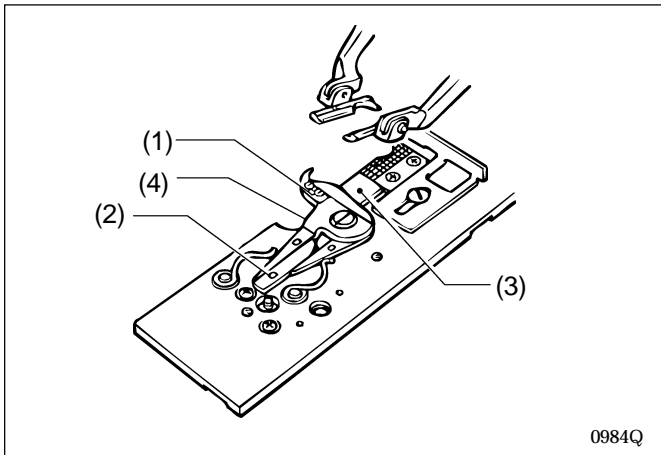

1. The mechanism is adjusted so that the lower thread and gimp are spread by the thread handler (1).
2. The movable knife driving cam (2) operates, and the right movable knife (3) and left movable knife (4) mesh and the thread is cut.

9-17. Adjusting the gimp length after trimming (-02)

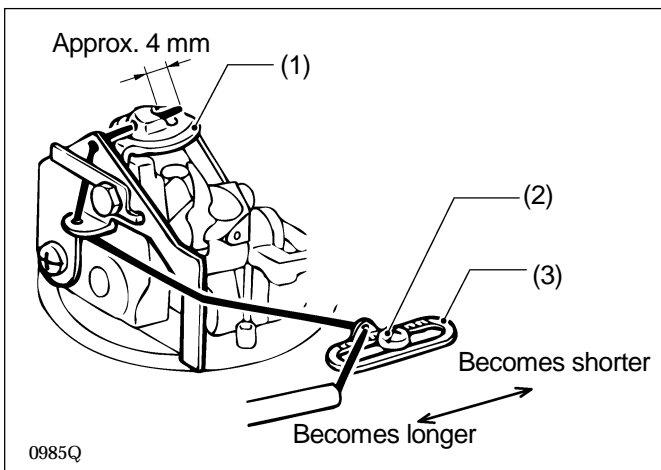

Adjust so that approximately 4 mm of the gimp thread is coming out from the throat plate (1).

1. Loosen the screw (2) and move the gimp thread guide J (3) in the direction of the arrow to adjust the length.

9-18. Lower thread presser (-02)

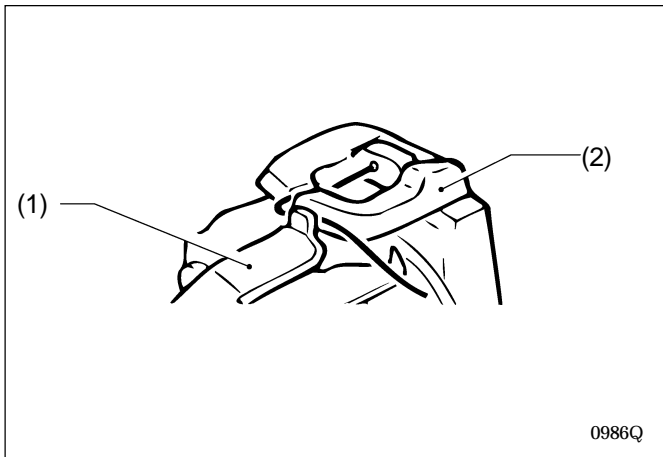

The lower thread presser (1) operates at the same time as upper thread trimming is carried out. The end of the lower thread is securely held between the lower thread presser (1) and the throat plate (2).

9-19. Sub presser (-02)

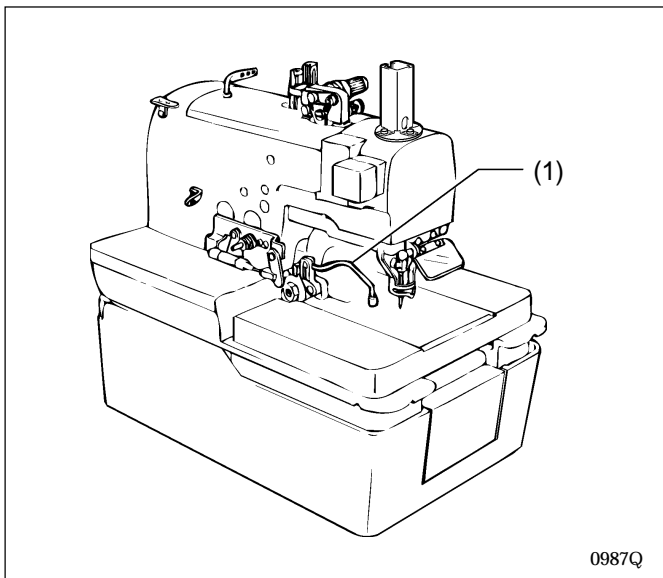

Trimming of the lower thread and gimp is carried out when the cloth pressers rise. The sub presser (1) ensures that the material does not move during thread trimming, in order to maintain a stable thread length after trimming.

10. SUMMARY OF DIP SWITCHES

Always turn off the power supply before changing any of the DIP switch settings.

10-1. Front panel DIP switches

The ON/OFF positions of the DIP switches inside the front panel are checked only once when the power is turned on. Any changes to the DIP switch positions will not be effective until the power is switched off and back on again.

No.	ON/OFF	Description
1 ^{*1}	ON	Program mode disabled
	OFF	Program mode enabled
2	ON	Spare
	OFF	Spare
3	ON	Front position
	OFF	Back position
4	ON	Counting down to zero
	OFF	Counting up from zero
5	ON	Pedal 1 operation
	OFF	Pedal 2 operation
6 ^{*3}	ON	Compatible with normally closed-type emergency stop switch (new)
	OFF	Compatible with normally open-type emergency stop switch (old)
7 ^{*2}	ON	Upper thread remaining amount = Large
	OFF	Upper thread remaining amount = Standard
8	ON	Spare
	OFF	Spare

*1 The version of the PROM is given as "E1" or later.

*2 The version of the PROM is given as "D1" or later.

*3 The version of the PROM is given as "F1" or later.

If the position of DIP switch No. 4 is changed, the production counter will be reset to zero.

* The machine is shipped from the factory with the DIP switches set as follows.

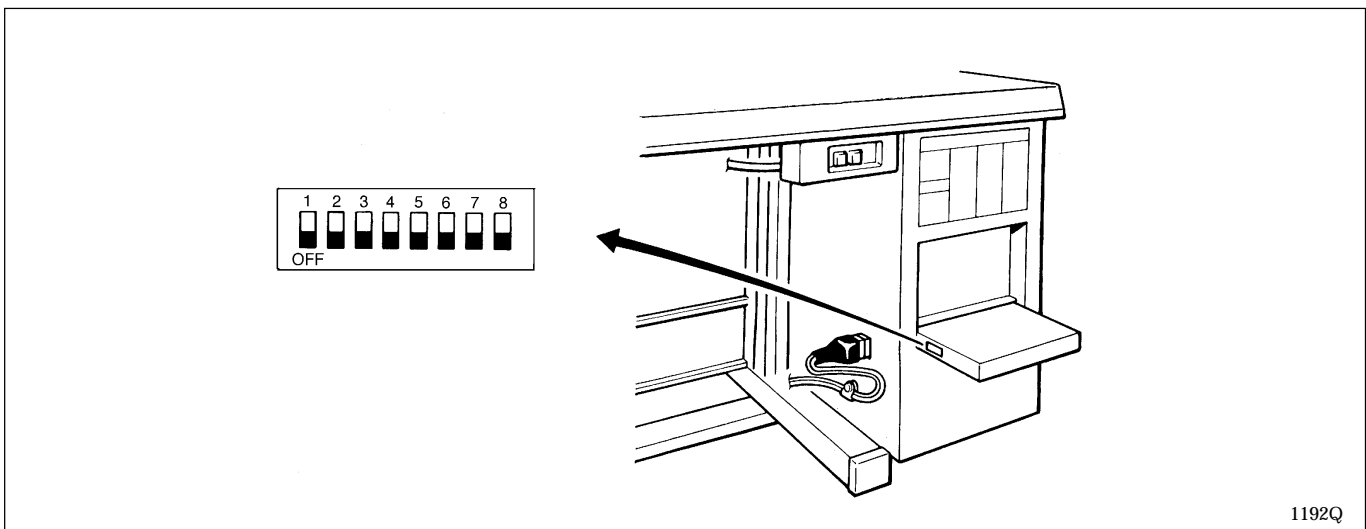

1192Q

10-2. Circuit board DIP switches

⚠ DANGER

Wait at least 5 minutes after turning off the power switch and disconnecting the power cord from the wall outlet before opening the face plate of the control box. Touching areas where high voltages are present can result in severe injury.

The ON/OFF positions of the DIP switches inside the front panel are checked only once when the power is turned on. Any changes to the DIP switch positions will not be effective until the power is switched off and back on again. Only one of DIP switch No.1, 2 and 3 is effective at any one time. They are effective in the order 1, 2, 3.

No.	ON/OFF	Description
1	ON	Data initialization
	OFF	Normal
2	ON	Input check
	OFF	Normal
3	ON	Output check
	OFF	Normal
4 ^{*1}	ON	Upper gimp guide present
	OFF	Upper gimp guide not present
5 ^{*2}	ON	Upper thread nipper present
	OFF	Upper thread nipper not present
6	ON	Upper and lower thread trimming
	OFF	Upper thread trimming
7	ON	Material is remains pressed after sewing
	OFF	Material is released after sewing
8	ON	Needle bar returns to home position after set number of pieces sewn
	OFF	Needle bar always returns to home position after each piece sewn

*1 The version of the PROM is given as "E1" or later.

*2 The version of the PROM is given as "D1" or later.

If the stitch length has been set to 39 mm or greater, it will be automatically changed to 38 mm if DIP switch No. 6 is changed to ON.

* The machine is shipped from the factory with the DIP switches set as follows.

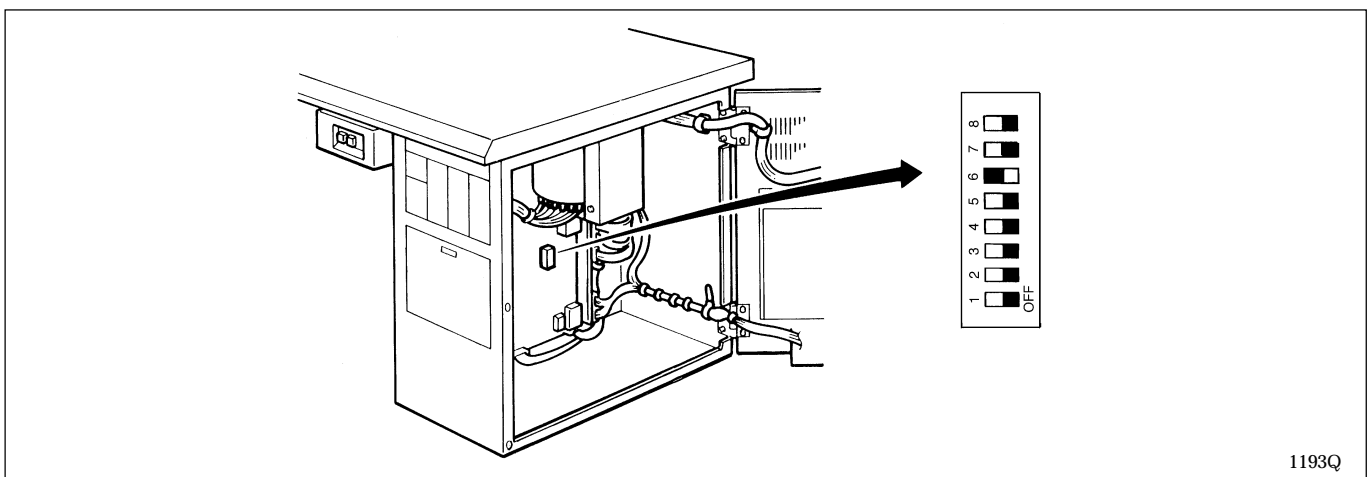

1193Q

11. TROUBLESHOOTING

If there is a problem with operation, first check that the threads are correctly threaded and that the needle is correctly installed.

CAUTION



Turn off the power switch and disconnect the power cord before carrying out troubleshooting, otherwise the machine will operate if the start switch is pressed by mistake, which could result in injury.

MACHINE HEAD

Problem	Cause	Remedy	Page
Thread breaks.	Thread tension control nut pressure is too strong.	Adjust to an appropriate pressure.	32
	Thread is of poor quality.	Use a better-quality thread.	/
	Thread is too thick for the needle.	Use a differently-size needle.	/
	Needle groove or needle hole are not smooth.	Replace with a new needle.	16
	Needle and looper adjustment is incorrect.	Adjust the needle bar height or the looper and spreader height.	43
	Needle, looper, throat plate or thread path is damaged.	Repair the damage with an oilstone or buffer, or replace the damaged part.	/
Skipped stitches occur.	Thread tension control nut pressure is too strong or too weak.	Adjust to an appropriate pressure.	32
	Needle point is broken or bent.	Replace with a new needle.	16
	Needle and looper adjustment is incorrect, or clearance is incorrect.	Adjust correctly.	44
	Needle and needle guard adjustment is incorrect.	Adjust correctly.	47
	Looper tip is blunt.	Repair with an oilstone or replace the looper with a new one.	/
Needle breaks.	Needle is bent.	Replace with a new needle.	16
	Needle and looper adjustment is incorrect.	Adjust the needle bar height or the looper and spreader height.	43
	Needle and needle guard adjustment is incorrect.	Adjust correctly.	47

Problem	Cause	Remedy	Page
Upper thread is not cut.	Knife is blunt.	Replace with a new knife.	51
	Knife does not move to the full stroke because air pressure is too weak.	Adjust the air pressure.	51
	Upper thread trimmer knife is not picking up the upper thread.	Install the upper thread trimmer knife so that it cuts only one side of the upper thread loop.	53
	Movable knife is not picking up the needle thread because the last stitch is being skipped.	Refer to the remedies given under "Skipped stitches occur" in this troubleshooting chart.	58
	Movable knife position is incorrect.	Adjust the position of the movable knife or the loop spreader.	53
Lower thread is not cut.	Knife is blunt.	Replace with a new knife.	51
	Knife does not move to the full stroke because air pressure is too weak.	Adjust the air pressure.	51
	Movable knife position is incorrect.	Adjust the position of the movable knife or the loop spreader.	53
Thread slips out of the needle at the sewing start.	Thread nipper spring force is too weak.	Adjust the force of the thread nipper spring.	53
	Upper thread length is too short after trimming.	Install the upper thread trimmer knife so that it cuts only one side of the upper thread loop.	53
	Needle and looper adjustment is incorrect.	Adjust the needle bar height or the looper and spreader height.	43
	Not enough upper thread is being fed out.	Adjust the amount of upper thread being fed out.	45
Material is not being cut cleanly.	Cutting pressure is too weak.	Adjust the cutting pressure so that it is strong enough.	51
	Knife and cutting block are not contacting properly.	Grind the cutting block surface.	50
	Knife is blunt.	Replace with a new knife.	51
	Cutter arm operation time is too short.	Make the operation time longer by changing the memory switch setting.	49

brother®

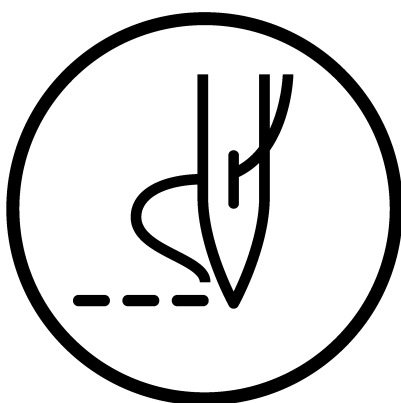

INSTRUCTION MANUAL

BROTHER INDUSTRIES, LTD.

15-1, Naeshiro-cho, Mizuho-ku, Nagoya 467-8561, Japan. Phone: 81-52-824-2177

Printed in Japan

118-980
S91980-302
2001.11. H (1)