

THANK YOU!

CONGRATULATIONS ON PURCHASING THE ULTIMATE BROTHER FAX MACHINE. WE ARE SURE YOU WILL BE THRILLED WITH THE CONVENIENT WAY YOUR NEW FAX MACHINE PERFORMS SO MANY TASKS WITH DAZZLING RESULTS!

Follow these simple instructions in numerical order.

For more details, press **Reports** and **1** on your fax machine or see your Owner's Manual.

If you cannot solve a problem: See to **Frequently Asked Questions (FAQs)** on Brother World Wide Web;

URL: <http://solutions.brother.com>

Call Brother Customer Service at:

USA: 1-800-284-4329 (9AM-5PM EST)
1-800-284-3238 (TTY service for the hearing impaired)
In Canada: 1-877-BROTHER (8AM-8PM EST)
(514) 685-6464 (in Montreal)

1 Packing List

Make sure you have the following items:

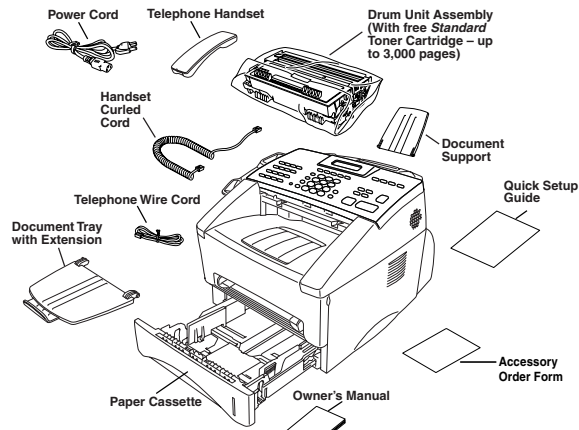

Keep the packing materials for possible future transport. If you do not pack the machine properly, you may void your warranty.

2 Install the Drum Unit

A. Unpack the drum unit assembly, including the toner cartridge. Gently rock it from side to side five or six times to distribute the toner evenly inside the cartridge.

! To prevent damage to the drum, do not expose it to light for longer than a few minutes.

B. Remove the yellow protective insert.

C. Open the front cover of the machine.

D. Insert the drum unit assembly into the machine.

E. Close the front cover.

3 If you have the Optional Paper Cassette #2, install it by:

A. Carefully pick up the machine and place it on top of Paper Cassette #2.
B. Plug the modular cable from Cassette #2 into the modular jack on the Brother machine.

To select which cassette will be used for printing, see Chapter 4 in the Owner's Manual.

If you move the machine after connecting Cassette #2, be sure to lift Cassette #2 with the machine because they are not attached.

4 Attach Document Tray and Support

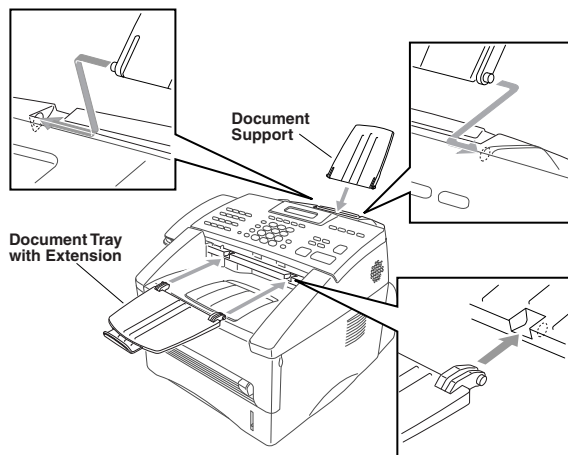

5 Load Paper

A. Pull the paper cassette completely out of the machine.

B. Slide the paper size and length adjusters of paper cassette for the paper size you want.

C. Load paper in the paper cassette. Press down on the paper to flatten all four corners. Keep the paper level below the guide.

D. Slide the paper cassette into the machine until it locks into place.

6 Install Phone Line, Handset, and Power Cord.

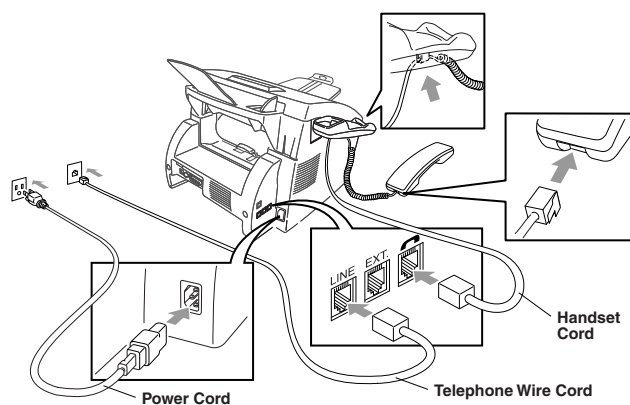

7 If you are sharing one phone line with an external telephone answering device (TAD), connect it now.

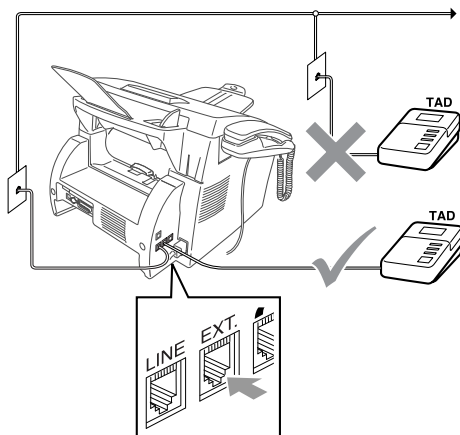

8 Select a Receive Mode

Choose the mode that best suits your needs by pressing the **Mode** button repeatedly until the FAX and FAX/TEL lights show the setting you want to use.

Manual

Fax
 TAD
 F/T

You must answer every call yourself. The Brother machine must be started manually to receive faxes.

Fax

Fax
 TAD
 F/T

For use with a dedicated fax line. Every call is answered as a fax.

Fax/Tel

Fax
 TAD
 F/T

For receiving fax and voice calls on one line. The FAX answers every call and receives a fax or double rings for you to pick up a voice call.

TAD

Fax
 TAD
 F/T

For use with an answering device. The TAD answers every call and stores voice messages. Fax messages are printed.

9 Set Date and Time

A. Press **Menu**, **1**, **2**.

2. DATE/TIME
YEAR: XX
ENTER & SET KEY

B. Enter the last two digits of the year and press **Set**.

MONTH: XX
ENTER & SET KEY

C. Enter two digits for the month and press **Set**.

DAY: XX
ENTER & SET KEY

D. Enter two digits for the day and press **Set**.

TIME: XX:XX
ENTER & SET KEY

E. Enter the time in 24-hour format and press **Set**, and then **Stop/Exit**.

Note: If you can't move forward, press **Stop/Exit** and start over at Step A.

10 Set Station ID

To print your name and fax number on all fax pages.

A. For the FAX, press **Menu**, **1**, **3**.

3. STATION ID
FAX:
ENTER & SET KEY

B. Enter your fax number, and then press **Set**.

TEL:
ENTER & SET KEY

C. Enter your telephone number, and then press **Set**.

NAME:
ENTER & SET KEY

D. Enter your name using the dial pad and the chart below, then press **Set**. Use the right arrow to create spaces.

E. Press **Stop/Exit**.

For more details, see Chapter 4 in the Owner's Manual.

Note: If you can't move forward, press **Stop/Exit** and start over at Step A.

Key	once	twice	three times	four times	five times
2	A	B	C	2	A
3	D	E	F	3	D
4	G	H	I	4	G
5	J	K	L	5	J
6	M	N	O	6	M
7	P	Q	R	7	P
8	T	U	V	8	T
9	W	X	Y	9	W

11 For the USA, complete the Warranty Registration and Test Sheet...

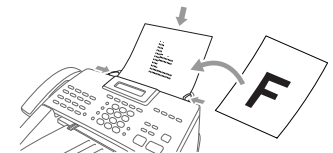
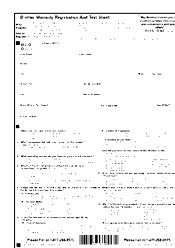

Press **Fax Start**.

...and fax it to Brother at: 1-877-268-9575

12 Install Printer Driver, Scanner Driver, PC-FAX Software and Remote Setup from the Web Site (For FAX-4750e Only)

You can download the Printer Driver, Scanner Driver, PC-FAX Software and Remote Setup from the Brother Solutions Center.

Visit us at:

<http://solutions.brother.com>