



P-touch

PARTS REFERENCE LIST

MODEL: PT-1100 / PT-1130 / PT-1170

ST-1150 (Heavy Duty Labeler™)

NOTES FOR USING THIS PARTS REFERENCE LIST

1. In the case of ordering parts, it needs mentioning the following items:

- (1) Code
- (2) Q'ty
- (3) Description
- (4) Symbol (PCB No., Revision , and Parts location mounted on the PCB.)

Note : No orders without Parts Code or Tool No. can be accepted.

[Example]

REF. NO.	SYMBOL	CODE	Q'TY	DESCRIPTION	REMARKS

Revision No. : marked on the printed circuit board.

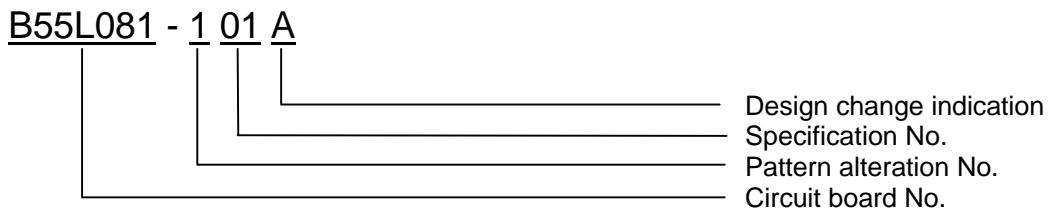

2. Design-changed parts:

When the parts are changed, any one of the following symbols is indicated in the REMARKS column.

- CHNG#A : compatible between old and new
- CHNG#B : replaceable from old to new
- CHNG#D : incompatible
- ADD : newly established

3. The original of this list was made based on the information available in May, 2000.

4. Parts are subject to change in design without prior notice.

CONTENTS

1 . RUBBER KEY.....	1
2 . SUB PCB.....	1
3 . PRINT MECHANISM	3
4 . COVERS	5
5 . MAIN PCB	7
6 . PRINTED MATTER	9
7 . PACKING MATERIALS.....	11

1 . RUBBER KEY

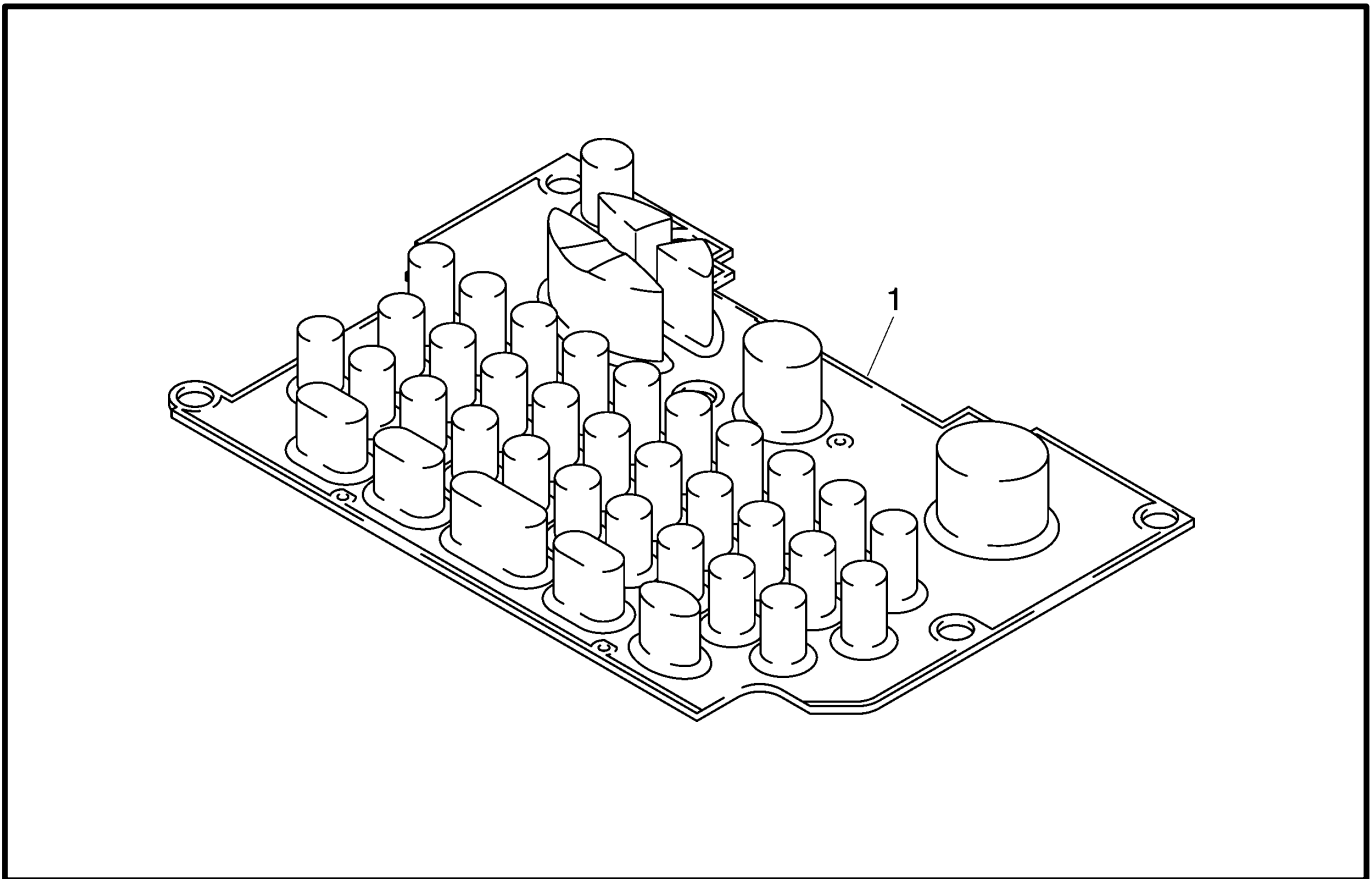

MODEL PT-1100/ST-1150 8V2-351-003

2 . SUB PCB

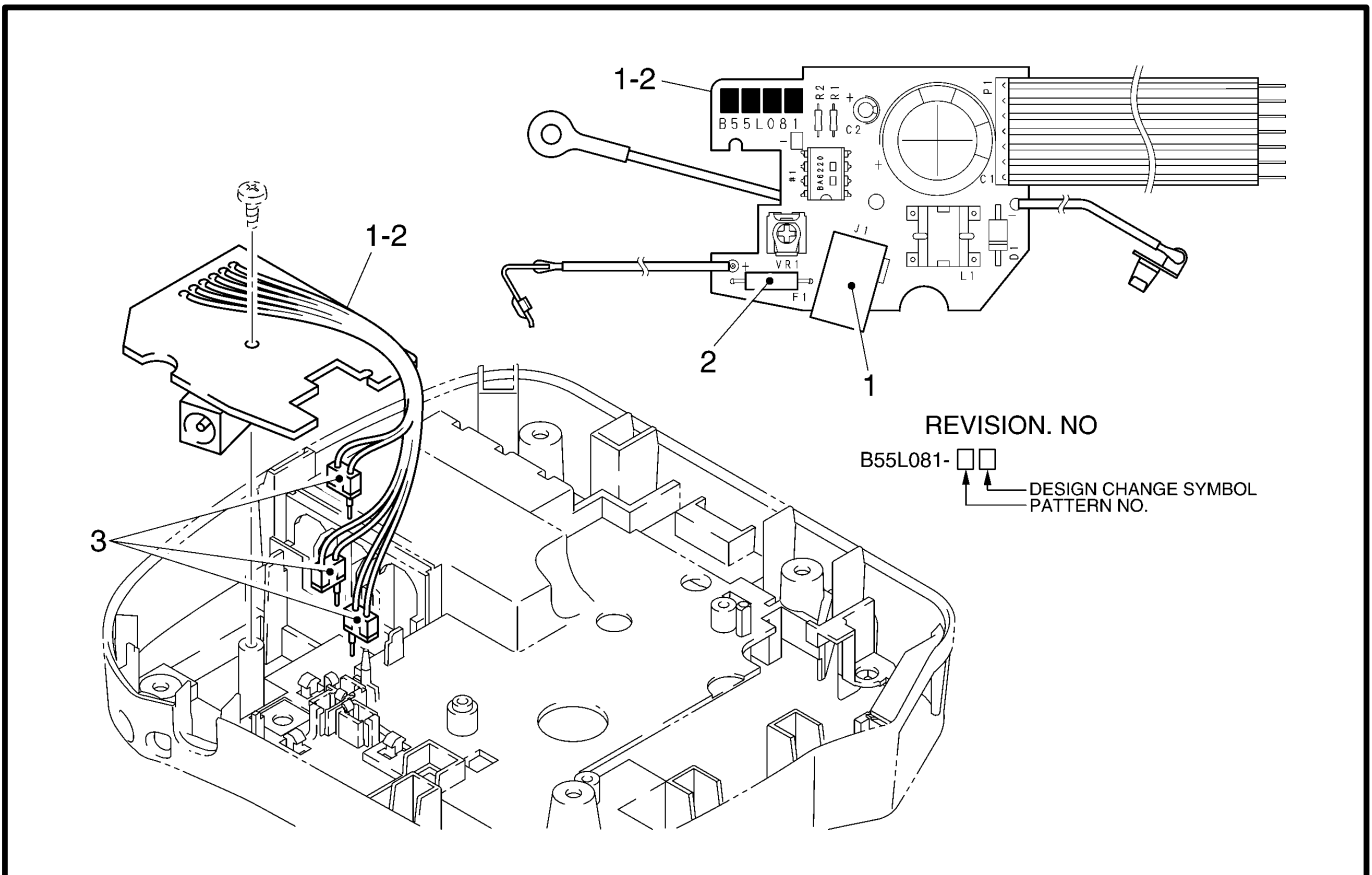

MODEL PT-1100/ST-1150 8V2-351-102

1 . RUBBER KEY

PT2001009

REF.NO.	CODE	Q'TY	DESCRIPTION	REMARKS
1	LA3180001	1	RUBBER 41 KEY 1100 US, (USA/AUS) (PT-1100/1100C)	
1	LA3180002	1	RUBBER 41 KEY 1100 US, (USA/CAN) (ST-1150C/1150DX)	
1	LA3180005	1	RUBBER 41 KEY 1100 US, (USA) (PT-1130)	ADD
1	LA3180006	1	RUBBER 41 KEY 1100 US, (USA) (PT-1170CC)	ADD
1	LA5662001	1	RUBBER 41 KEY 1100 SN, (HKG) (PT-1100SN)	ADD

MODEL PT-1100/ST-1150 8V2-351-003

2 . SUB PCB

PT2000054

REF.NO.	SYMBOL	CODE	Q'TY	DESCRIPTION	REMARKS
1-2	B55L081-1	LA3663001	1	SUB PCB ASSY PT1100 (SP)	
1	J1	W00325001	1	JACK, HECO470	
2	F1	UN0999000	1	FUSE,125V4A	
3		LA3240001	3	SWITCH ASSY PT1100	CHNG

MODEL PT-1100/ST-1150 8V2-351-102

3 . PRINT MECHANISM

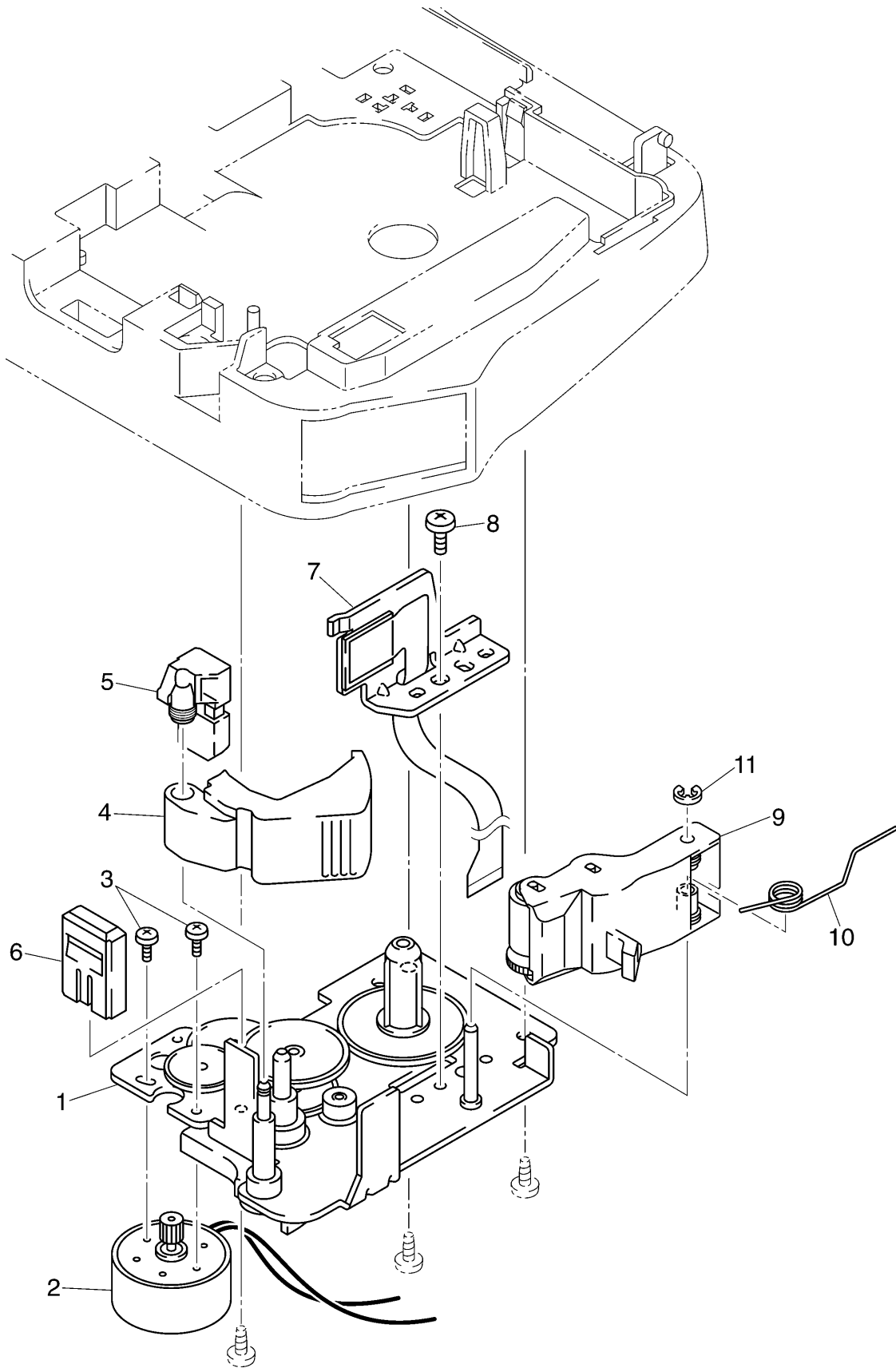

MODEL PT-1100/ST-1150 8V2-351-045

3 . PRINT MECHANISM

PT2001009

REF.NO.	CODE	Q'TY	DESCRIPTION	REMARKS
1	LA3181001	1	FRAME ASSY 1100	
2	LA3963001	1	DC MOTOR ASSY F	
3	UN3640001	2	SCREW, PAN 1.7X2.5	
4	LA3198001	1	CUTTER LEVER, (USA/AUS/HKG) (PT-1100/1100C/1100SN)	CHNG
4	LA3198004	1	CUTTER LEVER, (USA/CAN) (ST-1150C/1150DX)	
4	LA3198005	1	CUTTER LEVER, (USA) (PT-1130)	ADD
4	LA3198006	1	CUTTER LEVER, (USA) (PT-1170CC)	ADD
5	LA3199001	1	CUTTER CASE ASSY	
6	LA3203001	1	BOARD	
7	LA3664001	1	HEAD ASSY, KF1800-21 (SP)	
8	060300415	1	SCREW, BIND M3X4	
9	LA3209001	1	ROLLER HOLDER ASSY 1100	
10	LA3218001	1	ROLLER HOLDER RELEASE SPRING	
11	048020346	1	RETAINING RING, E2	

MODEL PT-1100/ST-1150 8V2-351-045

4. COVERS

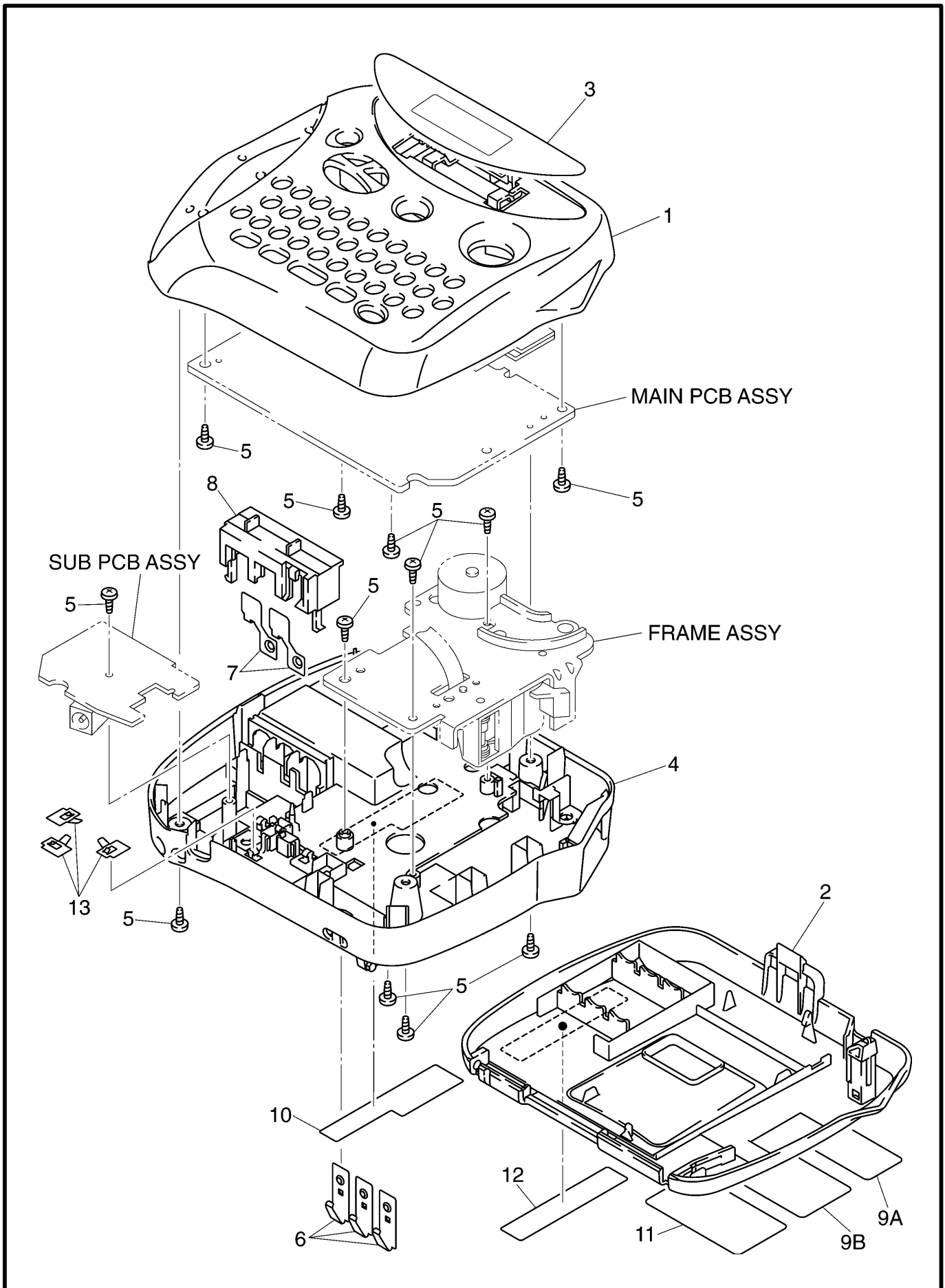

MODEL PT-1100/ST-1150 8V2-351-061

4 . COVERS

PT2001009

REF.NO.	CODE	Q'TY	DESCRIPTION	REMARKS
1	LA3220001	1	UPPER COVER ASSY 1100, (USA/AUS) (PT-1100/1100C)	
1	LA3220002	1	UPPER COVER ASSY 1100, (USA/CAN) (ST-1150C/1150DX)	
1	LA3220005	1	UPPER COVER ASSY 1100, (USA) (PT-1130)	ADD
1	LA3220006	1	UPPER COVER ASSY 1100, (USA) (PT-1170CC)	ADD
1	LA5663001	1	UPPER COVER ASSY 1100SN, (HKG) (PT-1100SN)	ADD
2	LA3223001	1	CASSETTE COVER ASSY 1100, (USA/AUS/HKG) (PT-1100/1100C/1100SN))	CHNG
2	LA3250002	1	CASSETTE COVER ASSY 1150, (USA/CAN) (ST-1150C/1150DX)	
2	LA5052001	1	CASSETTE COVER ASSY 1130, (USA) (PT-1130)	ADD
2	LA5764001	1	CASSETTE COVER ASSY 1170, (USA) (PT-1170CC)	ADD
3	LA3226001	1	LCD PANEL 1100 US (USA) (PT-1100)	
3	LA3952001	1	LCD PANEL 1150 US (USA) (ST-1150C)	
3	LA3249001	1	LCD PANEL 1150 CA (CAN/USA) (ST-1150C/1150DX)	
3	LA3774001	1	LCD PANEL 1100 AUS (AUS) (PT-1100C)	
3	LA5054001	1	LCD PANEL 1130 US (USA) (PT-1130)	ADD
3	LA5766001	1	LCD PANEL 1170 US (USA) (PT-1170CC)	ADD
3	LA5664001	1	LCD PANEL 1100SN (HKG) (PT-1100SN)	ADD
4	LA3227001	1	BOTTOM COVER 1100 US, WHITE1552 (USA/AUS) (PT-1100/1100C)	
4	LA3227002	1	BOTTOM COVER 1100 US, GRAY1554 (USA/CAN) (ST-1150C/1150DX)	
4	LA3227005	1	BOTTOM COVER 1100 US, (USA)(PT-1130)	ADD
4	LA3227006	1	BOTTOM COVER 1100 US, (USA) (PT-1170CC)	ADD
4	LA5810001	1	BOTTOM COVER 1100 HK, (HKG) (PT-1100SN)	ADD
5	085270617	12	TAPTITE, BIND B M2.6X6	
6	LA3867000	3	BATTERY TERMINAL A (+,-)	
7	LA3228000	2	BATTERY TERMINAL B (+,-)	
8	LA3229001	1	TERMINAL PRESS COVER, WHITE1552	
9A	LA0492001	1	FCC LABEL 1200, US (USA) (PT-1100, ST-1150C/1150DX/1130/1170CC)	CHNG
9B	LA0518001	1	FCC LABEL 1200, CA (CAN) (ST-1150C)	
10	UN3739001	1	CUTTER CAUTION LABEL	
11	UN3740001	1	ADAPTER CAUTION LABEL (AUS) (PT-1100C)	
12	LA3997001	1	C-TICK MARK CH (AUS) (PT-1100C)	
13	LA3573000	3	SWITCH PRESSER PLATE	

MODEL PT-1100/ST-1150 8V2-351-061

5 . MAIN PCB

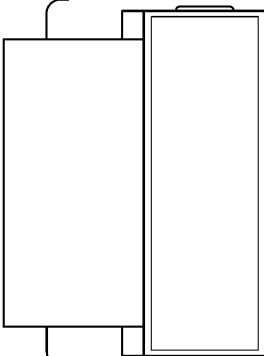
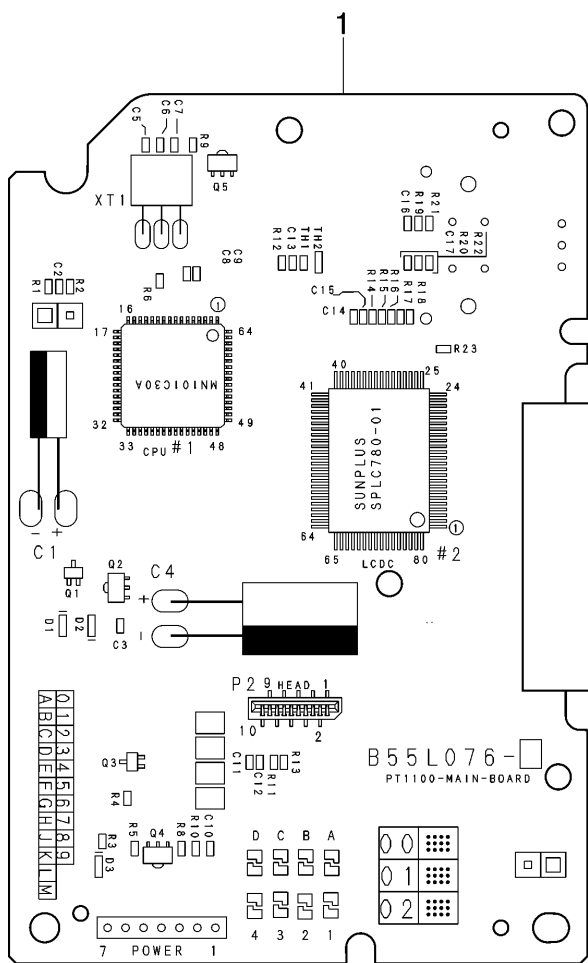
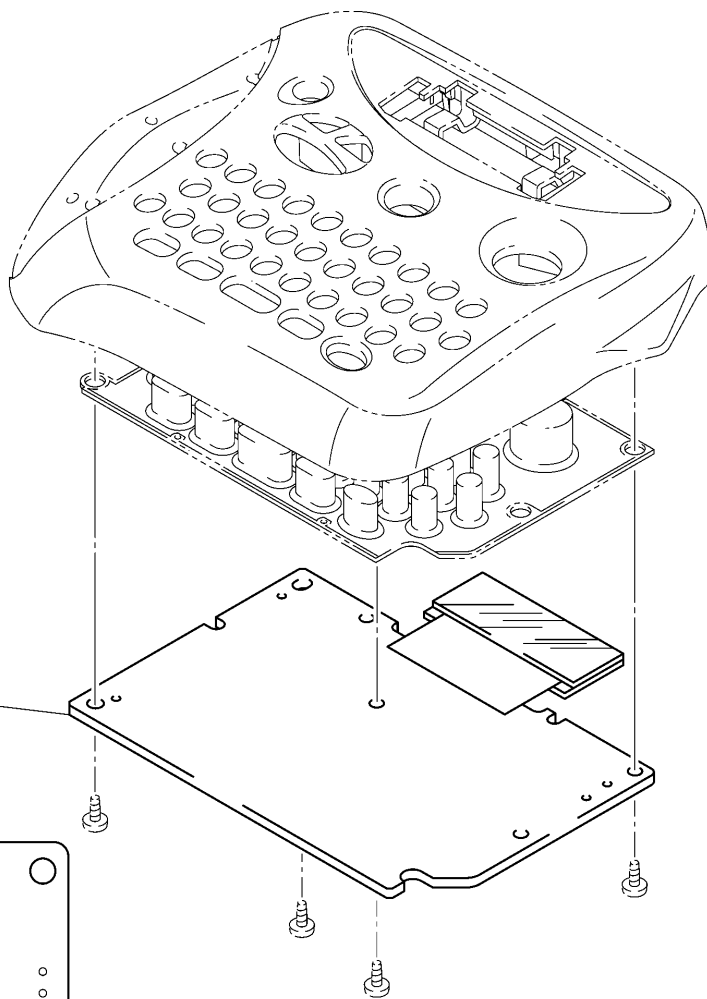

REVISION. NO

PATTERN NO.

B55L076-



DESIGN CHANGE SYMBOL SPEC. NO.

5 . MAIN PCB

PT2001009

REF.NO.	SYMBOL	CODE	QTY	DESCRIPTION	REMARKS
1	B55L076-20	LA3662001	1	MAIN PCB ASSY PT1100 (SP), (USA/CAN//AUS) (PT1100/1100C,ST1150C/1150DX)	CHNG
1	B55L096-111	LA5808001	1	MAIN PCB ASSY PT1100 (SP), (HKG) (PT1100SN)	ADD

MODEL PT-1100/ST-1150 8V2-351-101

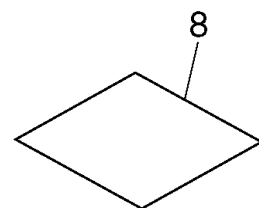
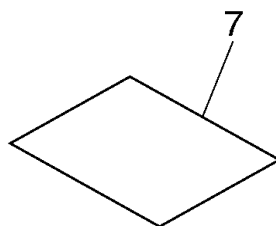
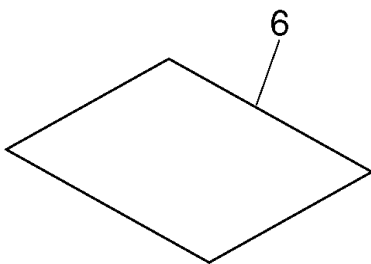
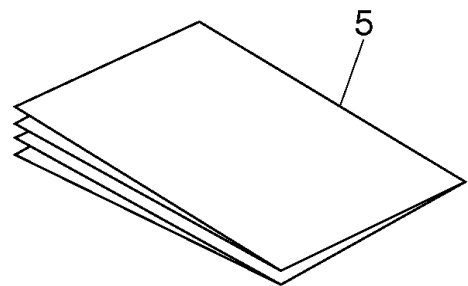
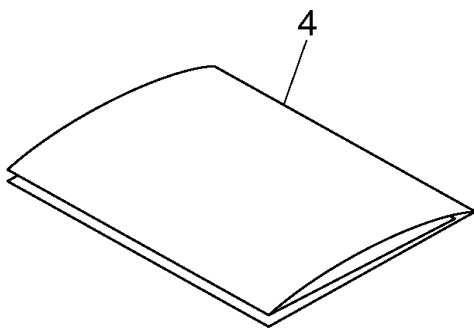
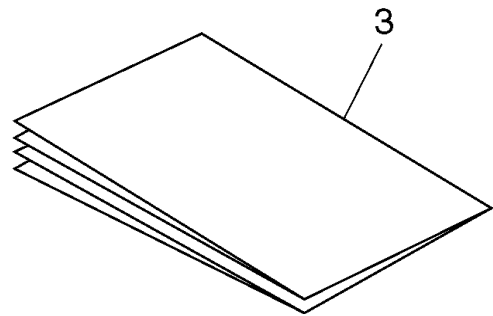
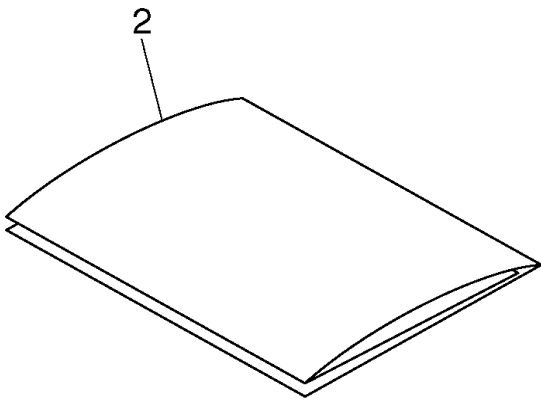
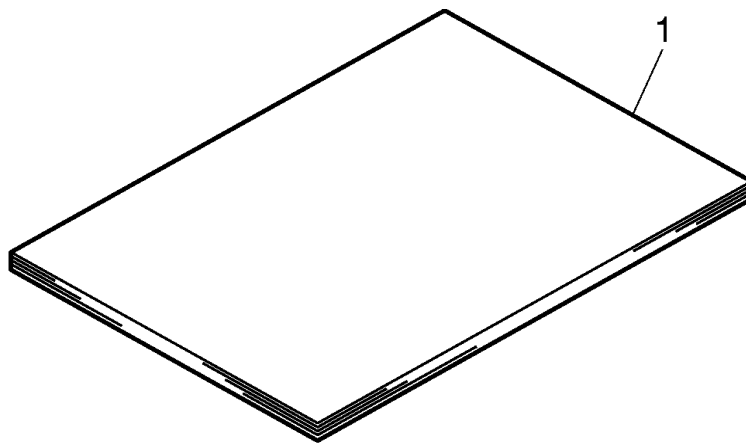

6 . PRINTED MATTER

PT2001009

REF.NO.	SYMBOL	CODE	Q'TY	DESCRIPTION	REMARKS
1		LA3242001	1	USER'S MANUAL 1100, USA.ENGLISH (USA) (PT-1100)	
1		LA3243001	1	USER'S MANUAL 1100, USA.SPANISH (USA) (PT-1100)	
1		LA3255001	1	USER'S MANUAL 1150, USA.ENGLISH (USA) (ST-1150C/1150DX)	
1		LA3256001	1	USER'S MANUAL 1150, USA.SPANISH (USA) (ST-1150C/1150DX)	
1		LA3268001	1	USER'S MANUAL 1150, CAN.ENGLISH (CAN) (ST-1150C)	
1		LA3269001	1	USER'S MANUAL 1150, CAN.FRENCH (CAN) (ST-1150C)	
1		LA3776001	1	USER'S MANUAL 1100, AUS.ENGLISH (AUS) (PT-1100C)	
1		LA5055001	1	USER'S MANUAL 1130, USA.ENGLISH (USA) (PT-1130)	ADD
1		LA5767001	1	USER'S MANUAL 1170, USA.ENGLISH (USA) (PT-1170CC)	ADD
1		LA5187001	1	USER'S MANUAL PT65/1100HK, (HKG) (PT-1100SN)	ADD
2	A	LA4059001	1	WARRANTY CARD US CH(USA) (PT-1100)	
2		LA3257001	1	WARRANTY CARD STANLEY (USA) (ST-1150C/1150DX)	
2		LA3270001	1	WARRANTY CARD STANLEY (CAN) (ST-1150C)	
2		LA5057001	1	WARRANTY CARD 1130US (USA) (PT-1130)	ADD
2		LA4059001	1	WARRANTY CARD US CH (USA) (PT-1170CC)	ADD
2		LA4592001	1	WARRANTY CARD, HONG KONG, (HKG) (PT-1100SN)	ADD
3		LA3258001	1	ACCESSORY ORDER FORM STANLEY (USA) (ST-1150C/1150DX)	
3		LA3697001	1	ACCESSORY ORDER FORM (USA) (PT-1100/1170CC)	CHNG
3		LA3271001	1	ACCESSORY ORDER FORM STANLEY (CAN) (ST-1150C)	
3		LA1825001	1	ACCESSORY ORDER FORM, US (USA) (PT-1100/1170CC)	CHNG
3		LA5058001	1	ACCESSORY ORDER FORM 1130, (USA) (PT-1130)	ADD
4		LA2895001	1	TZ TAPE CATALOG, AUS CH (AUS) (PT-1100C)	
5		LA3729001	1	INSERTION 1100, USA.ENGLISH (USA/CAN/AUS) (PT-1100/1100C/1130/1170CC, ST-1150C/1150DX)	CHNG
5		LA3730001	1	INSERTION 1100, USA.SPANISH (USA) (PT-1100/1130/1170CC, ST-1150C/1150DX)	CHNG
5		LA3734001	1	INSERTION 1150, CAN.FRENCH (CAN) (ST-1150C)	
6		LA4452001	1	LEGEND LABEL 1150 (CAN) (ST-1150C)	
7		LA3947001	1	LEGEND INSERTION 1150 (CAN) (ST-1150C)	
8		LA4044001	1	APPLICATION CARD 1150 (USA/CAN) (ST-1150C/1150DX)	

MODEL PT-1100/ST-1150 8V2-351-920

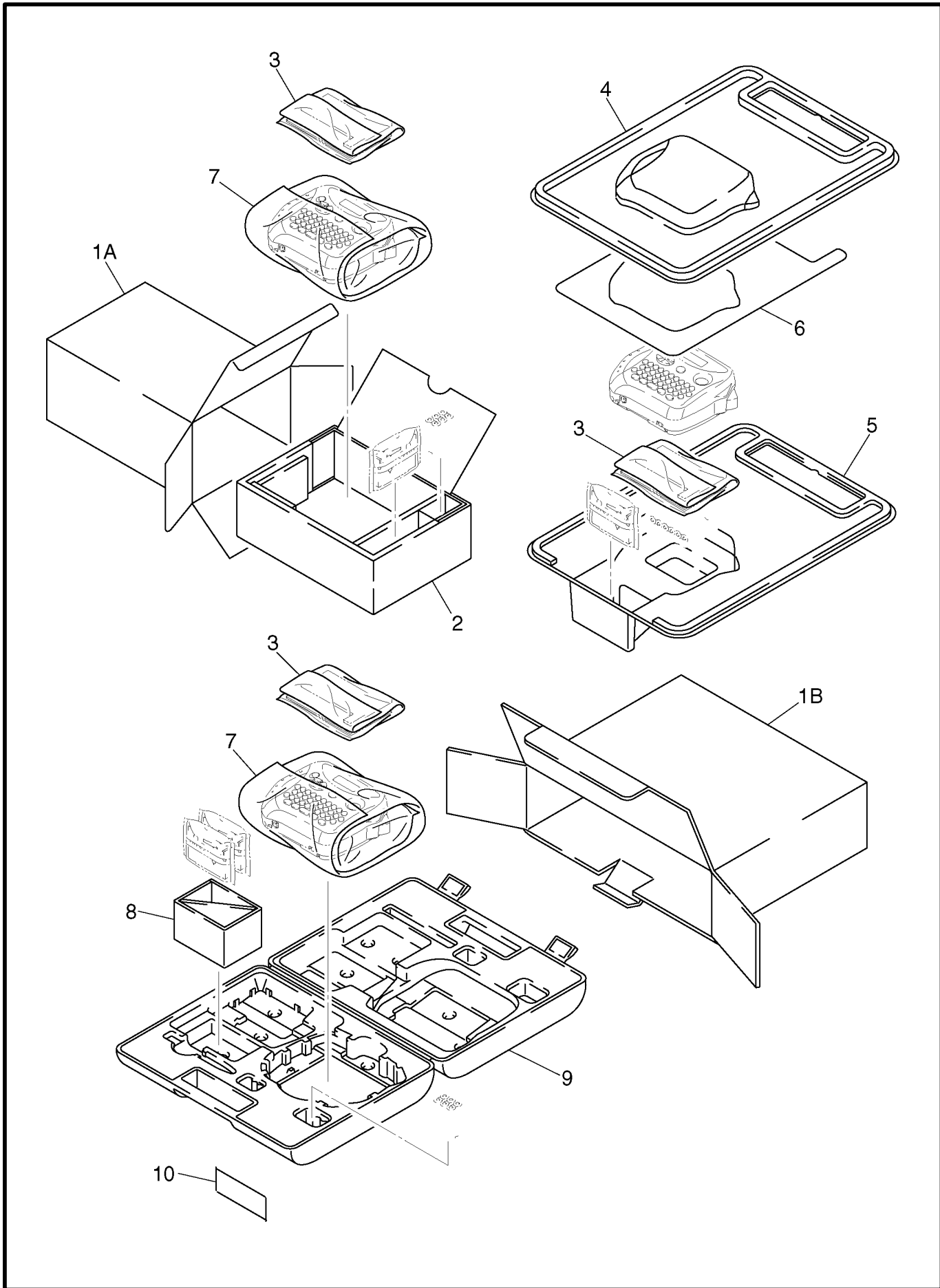

7 . PACKING MATERIALS

PT2001009

REF.NO.	CODE	Q'TY	DESCRIPTION	REMARKS
1A	LA3244001	1	CARTON 1100US (USA) (PT-1100)	
1A	LA5668001	1	CARTON 1100SN (HKG) (PT1100SN)	ADD
1B	LA3957001	1	CARTON 1150DX (USA) (ST-1150DX)	
1B	LA5763001	1	CARTON 1170CC (USA) (PT-1170CC)	ADD
2	LA3245000	1	PAD 1100 (USA/HKG) (PT-1100/1100SN)	CHNG
3	UN8931000	1	PE BAG, 135X250H (USER'S MANUAL)	
4	LA3261000	1	CLAM SHELL UPPER 1150 (USA/CAN/AUS) (ST-1150C, PT-1100C/1130)	CHNG
5	LA3262000	1	CLAM SHELL LOWER 1150 (USA/CAN/AUS) (ST-1150C/PT-1100C/1130)	CHNG
6	LA3263001	1	COMMERCIAL SHEET PT1150US (USA) (ST-1150C)	
6	LA3272001	1	COMMERCIAL SHEET PT1150CA (CAN) (ST-1150C)	
6	LA3777001	1	COMMERCIAL SHEET PT1100AUS (AUS) (PT-1100C)	
7	UN5224001	1	BAG, 215X360H (BODY) (USA/HKG) (PT-1100/1170CC/1100SN, ST-1150DX)	CHNG
8	LA3932000	1	CASSETTE PAD 1 (USA) (PT-1170CC, ST-1150DX)	CHNG
9	LA4526001	1	CARRYING CASE ST1150 (USA) (ST-1150DX)	CHNG
9	LA3626001	1	CARRYING CASE 65, (USA) (PT-1170CC)	ADD
10	LA4002001	1	CARRYING CASE LABEL STANLY (USA) (ST-1150DX)	
10	LA3996001	1	CARRYING CASE LABEL BRO (USA) (PT-1170CC)	ADD

MODEL PT-1100/ST-1150 8V2-351-930

brother[®]

May, 2001
8V2009BE0
Printed in Japan