

brother®

P-touch

PARTS REFERENCE LIST

MODEL: PT-1900/1910

MECHANISMS & ELECTRONICS

NOTES FOR USING THIS PARTS REFERENCE LIST

1. In the case of ordering parts, it needs mentioning the following items:

- (1) Code
- (2) Q'ty
- (3) Description
- (4) Symbol (PCB No., Revision , and Parts location mounted on the PCB.)

Note : No orders without Parts Code or Tool No. can be accepted.

[Example]

REF. NO.	SYMBOL	CODE	Q'TY	DESCRIPTION	REMARKS
	(4) ⋮	(1) ⋮	(2) ⋮	(3) ⋮	

Revision No. : marked on the printed circuit board.

B55L125 - 1 01 A

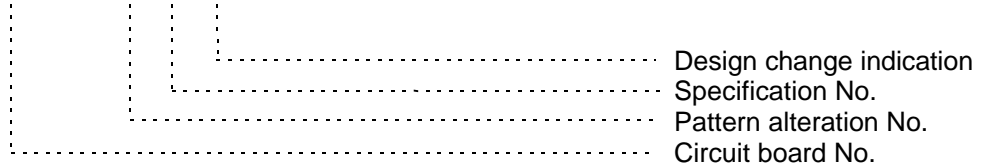

2. Design-changed parts:

When the parts are changed, any one of the following symbols is indicated in the REMARKS column.

- CHNG#A : compatible between old and new
- CHNG#B : replaceable from old to new
- CHNG#D : incompatible
- ADD : newly established

3. The original of this list was made based on the information available in April, 2002.

4. Parts are subject to change in design without prior notice.

CONTENTS

1 . RUBBER KEY.....	1
2 . POWER SUPPLY PCB.....	1
3 . PRINT MECHANISM	3
4 . COVERS	5
5 . MAIN PCB	7
6 . SENSORS.....	9
7 . PRINTED MATTER	9
8 . PACKING MATERIALS.....	11

1 . RUBBER KEY

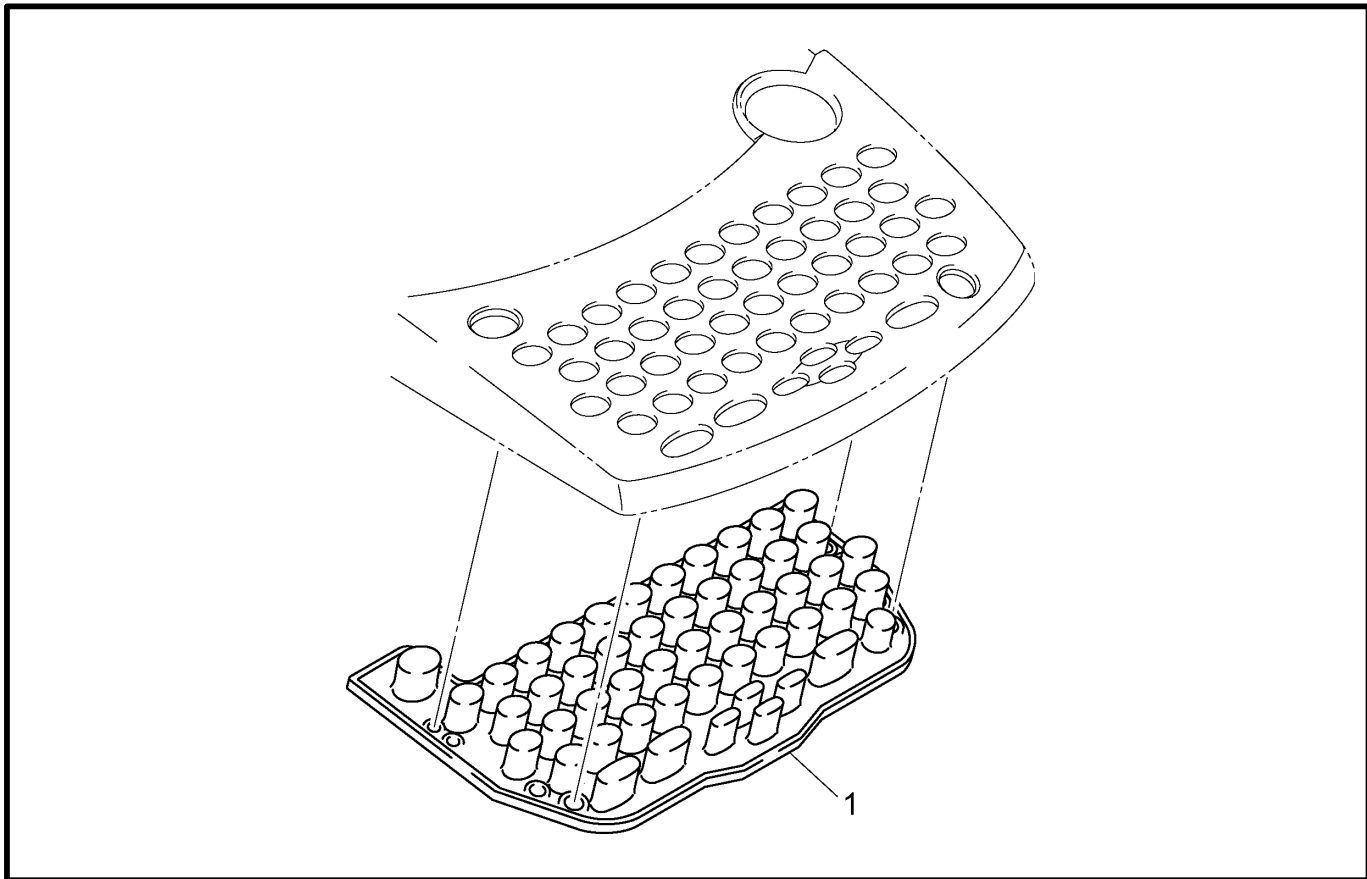

MODEL PT-1900/1910 8V2-325-003

2 . POWER SUPPLY PCB

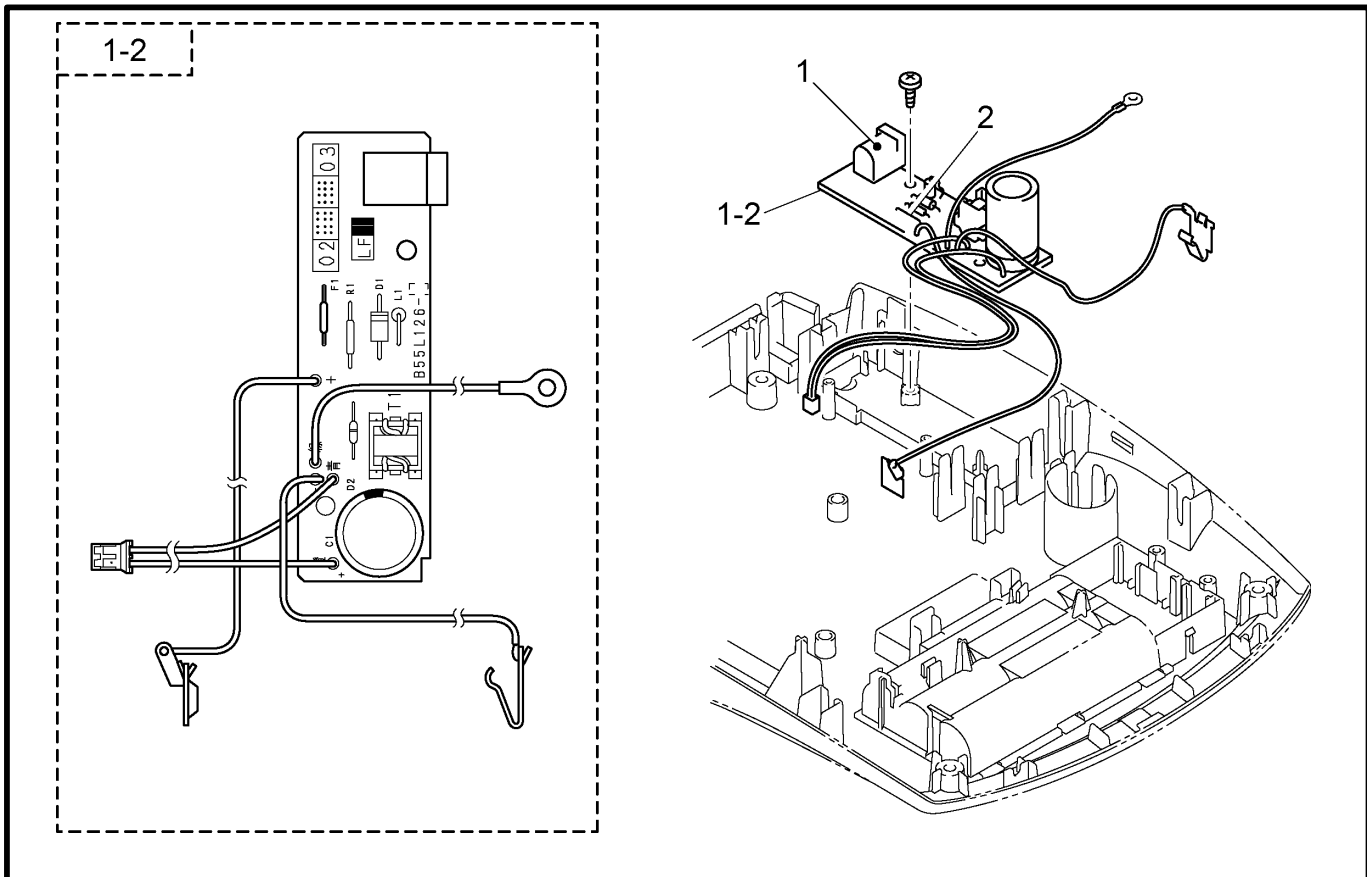

MODEL PT-1900/1910 8V2-325-102

1 . RUBBER KEY

REF.NO.	CODE	Q'TY	DESCRIPTION	REMARKS
1	LA7378001	1	RUBBER 51 KEY 1900 US	

MODEL PT-1900/1910 8V2-325-003

2 . POWER SUPPLY PCB

REF.NO.	SYMBOL	CODE	Q'TY	DESCRIPTION	REMARKS
1-2	B55L126-1A	LA7399001	1	POWER SUPPLY PCB ASSY	
1		W00325001	1	JACK, HEC0470	
2		UN0999000	1	FUSE, 125V4A	

MODEL PT-1900/1910 8V2-325-102

3. PRINT MECHANISM

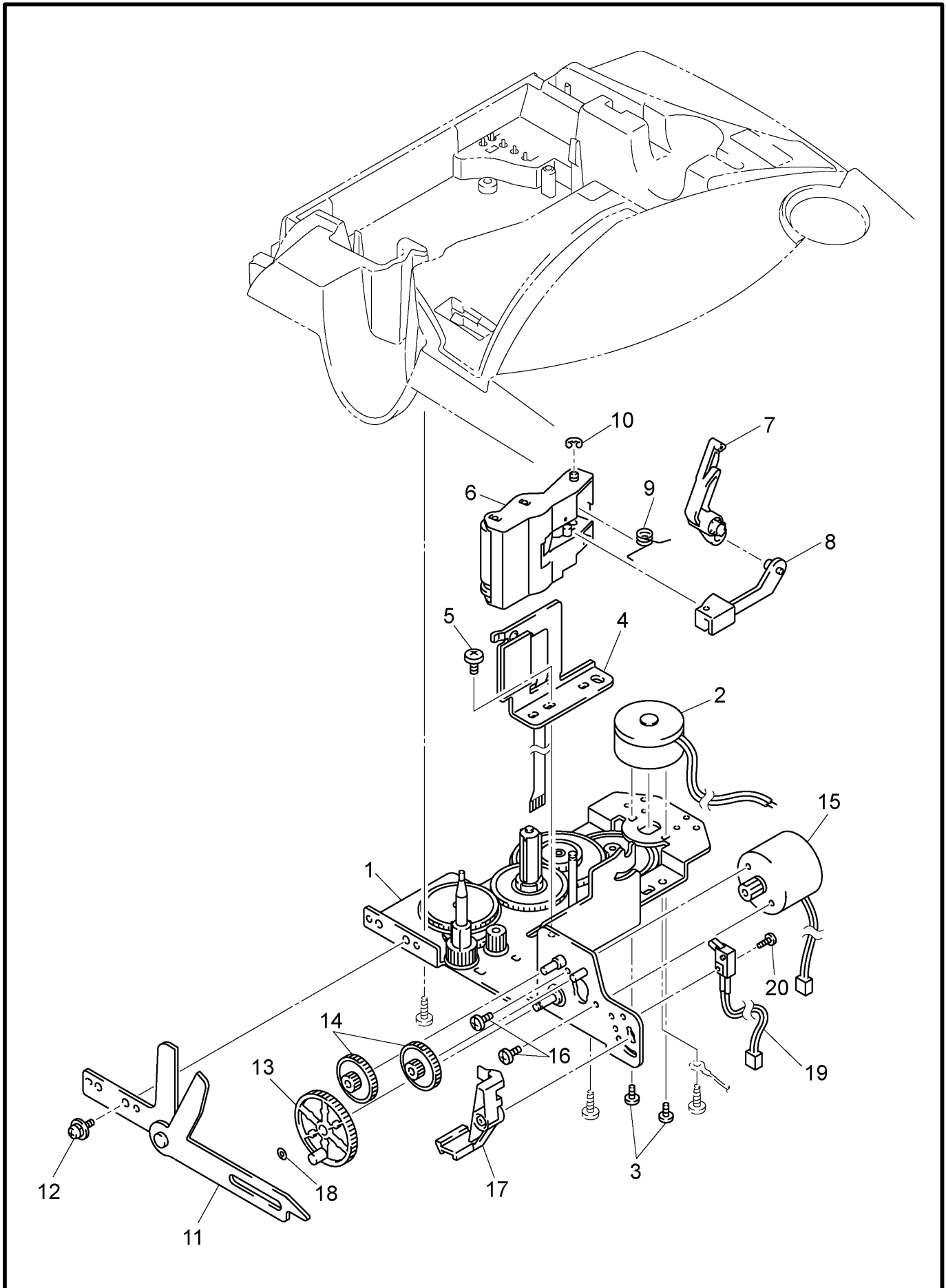

MODEL PT-1900/1910 8V2-325-045

3 . PRINT MECHANISM

REF.NO.	CODE	Q'TY	DESCRIPTION	REMARKS
1	LA5680001	1	CHASSIS ASSY 2300	
2	LA3963001	1	DC MOTOR ASSY F	
3	UN3640001	2	SCREW, PAN 1.7X2.5	
4	LA5688001	1	HEAD ASSY KV1801-26B	
5	060300415	1	SCREW, BIND M3X4	
6	LA4711001	1	ROLLER HOLDER ASSY 240	
7	LA4886001	1	ROLLER RELEASE LEVER 1750	
8	LA4887001	1	ROLLER HOLDER RELEASE ROD	
9	LA4888001	1	ROLLER HOLDER RELEASE SPRING	
10	048020346	1	RETAINING RING, E2	
11	LA6151001	1	CUTTER ASSY (SP)	
12	0A4300605	1	SCREW, PAN (S/P WASHER) M3X6	
13	UT0252001	1	CUTTER MOVING GEAR	
14	UT0254000	2	CUTTER DOUBLE GEAR	
15	LA5692001	1	CUTTER MOTER ASSY F	
16	062020305	2	SCREW, PAN M2X3	
17	LA0305001	1	ACTUATOR 2400	
18	UB3733001	1	WASHER 2.6	
19	UT1466001	1	FULL CUTTER SENSOR PRO ASSY	
20	UT0855001	1	SCREW, PAN M1.7X6	

MODEL PT-1900/1910 8V2-325-045

4. COVERS

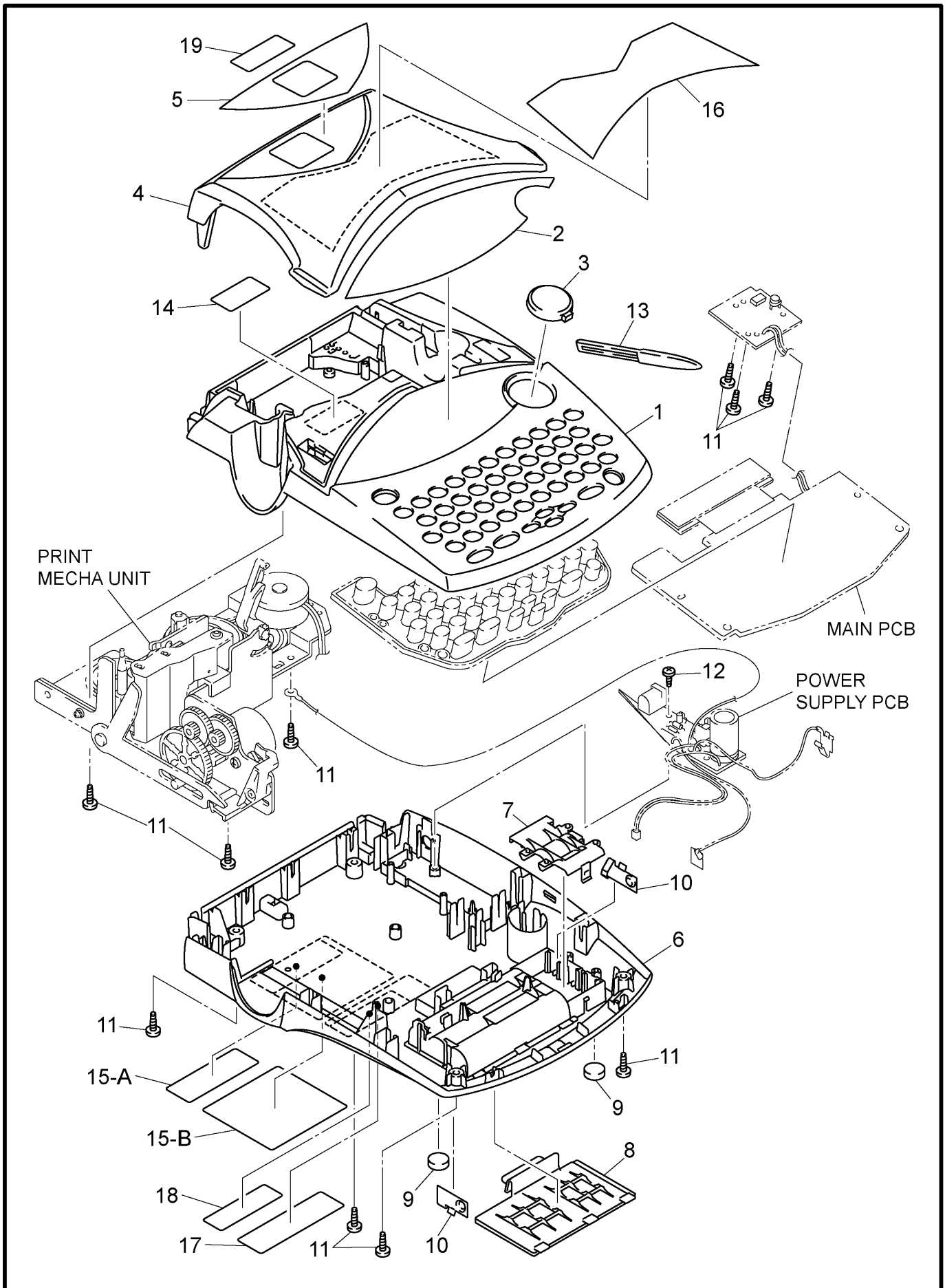

MODEL PT-1900/1910 8V2-325-061

4 . COVERS

REF.NO.	CODE	Q'TY	DESCRIPTION	REMARKS
1	LA7379001	1	UPPER COVER 1900 US, SILVER1585	
2	LA7380001	1	LCD PANEL 1900 US	
3	LA5696001	1	EMBLEM 2300	
4	LA7381001	1	CASSETTE COVER 1900, BLUE6350	
5	LA7382001	1	TAPE PANEL 1900 (USA/CAN) (PT-1900/1910)	
5	LA7797001	1	TAPE PANEL 1900 AUS (AUS) (PT-1900)	
6	LA7383001	1	BOTTOM COVER 1900, GRAY1593	
7	UN0401003	1	BLIND COVER, GRAY1593	
8	LA0092003	1	BATTERY LID PS, GRAY1593	
9	LA5753001	2	LOWER FOOT 2300	
10	UB3719000	2	BATTERY TERMINAL	
11	085270817	10	TAPTITE, BIND B M2.6X8	
12	085270615	1	TAPTITE, BIND B M2.6X6	
13	LA4896001	1	PEELER-STICK, GRAY1252	
14	LA5701001	1	LEVER CAUTION LABEL 2300 (USA) (PT-1900/1910)	
15-A	LA5702001	1	CAUTION LABEL 2300 US (USA) (PT-1900/1910)	
15-B	LA7857001	1	CAUTION LABEL 1850 EC (CAN/AUS) (PT-1900)	
16	LA7767001	1	MYLAR LABEL 1900 US (USA) (PT-1900)	
16	LA7769001	1	MYLAR LABEL 1900 AUS (AUS) (PT-1900)	
16	LA7768001	1	MYLAR LABEL 1910 US (USA) (PT-1910)	
17-A	LA7765001	1	FCC LABEL (USA) (PT-1900/1910)	
17-B	LA7766001	1	FCC LABEL CA (CAN) (PT-1900)	
18	LA4998001	1	C-TICK MARK (AUS) (PT-1900)	
19	LA7931001	1	LCD LABEL 1900 US (USA) (PT-1900)	

MODEL PT-1900/1910 8V2-325-061

5. MAIN PCB

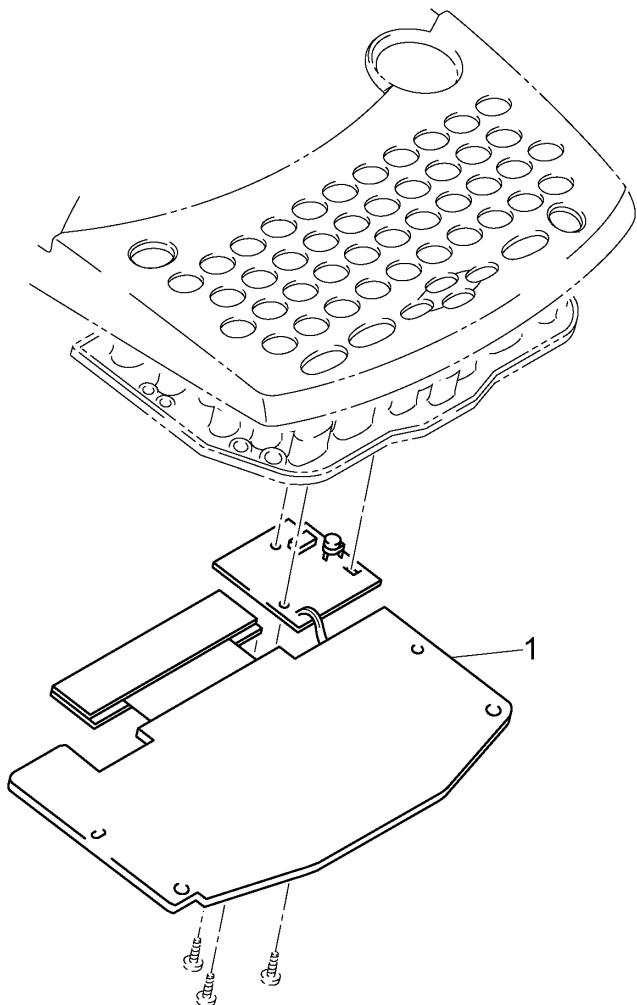
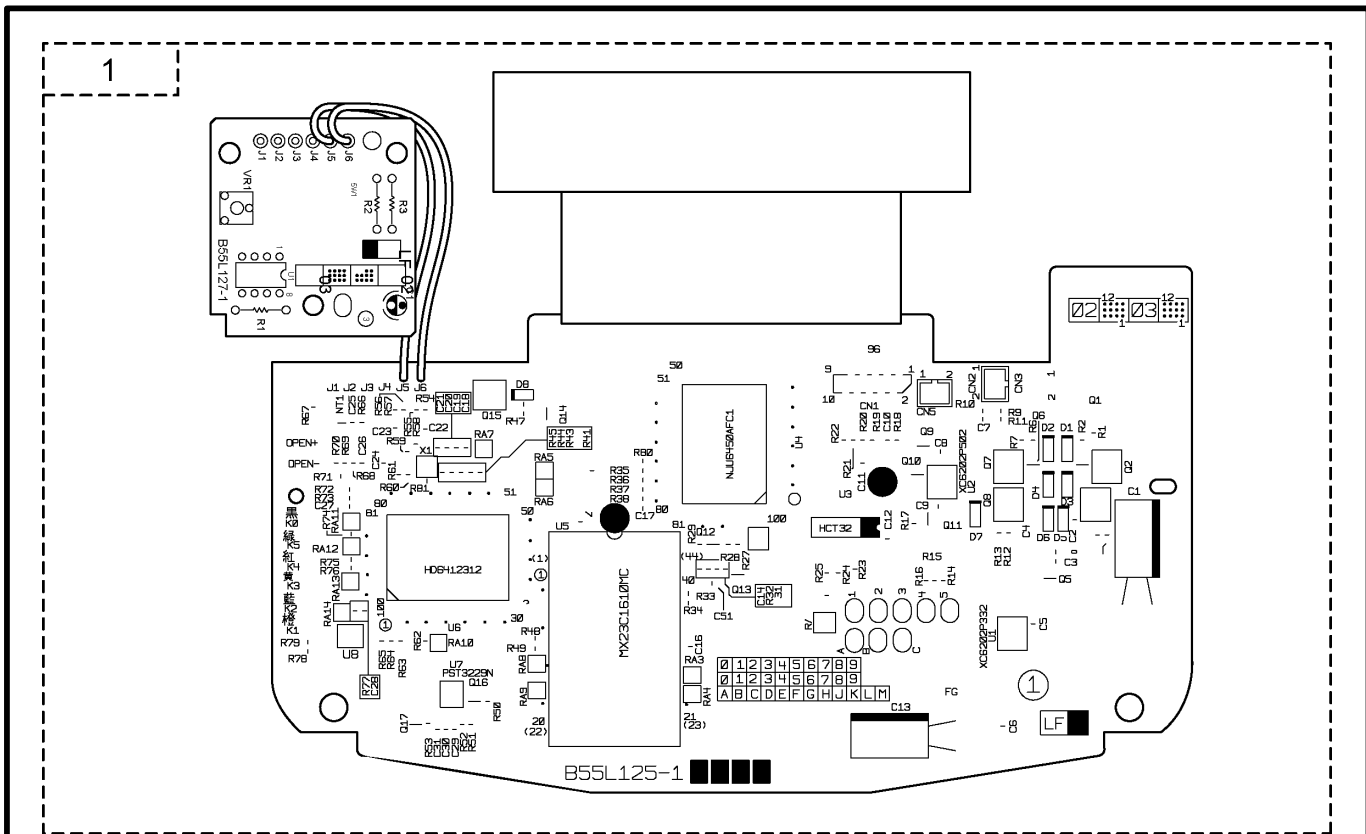

5 . MAIN PCB

REF.NO.	SYMBOL	CODE	Q'TY	DESCRIPTION	REMARKS
1	B55L125-1B	LA7460001	1	MAIN PCB UNIT 1900	

MODEL PT-1900/1910 8V2-325-101

6 . SENSORS

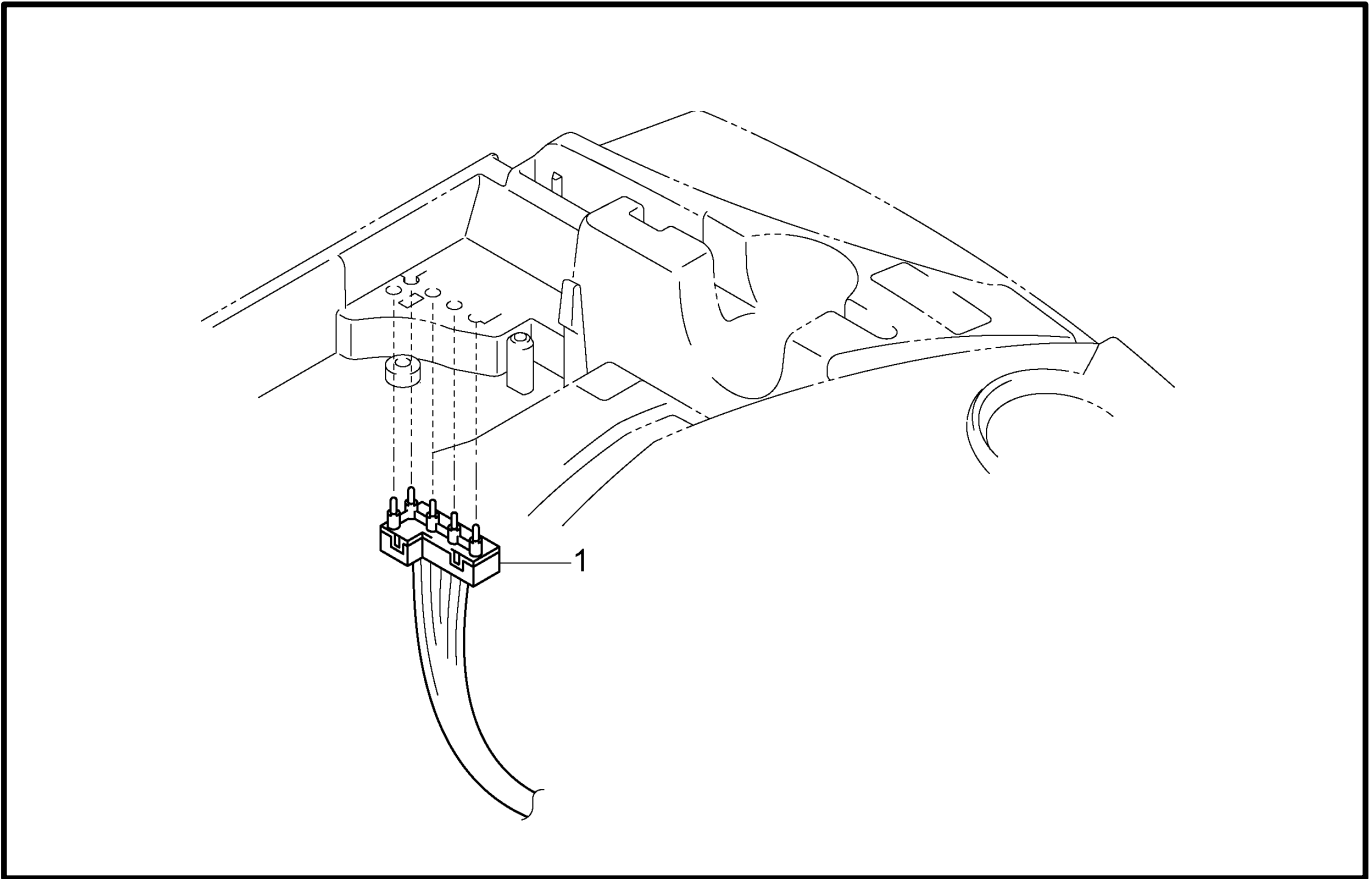

MODEL PT-1900/1910 8V2-325-100

7 . PRINTED MATTER

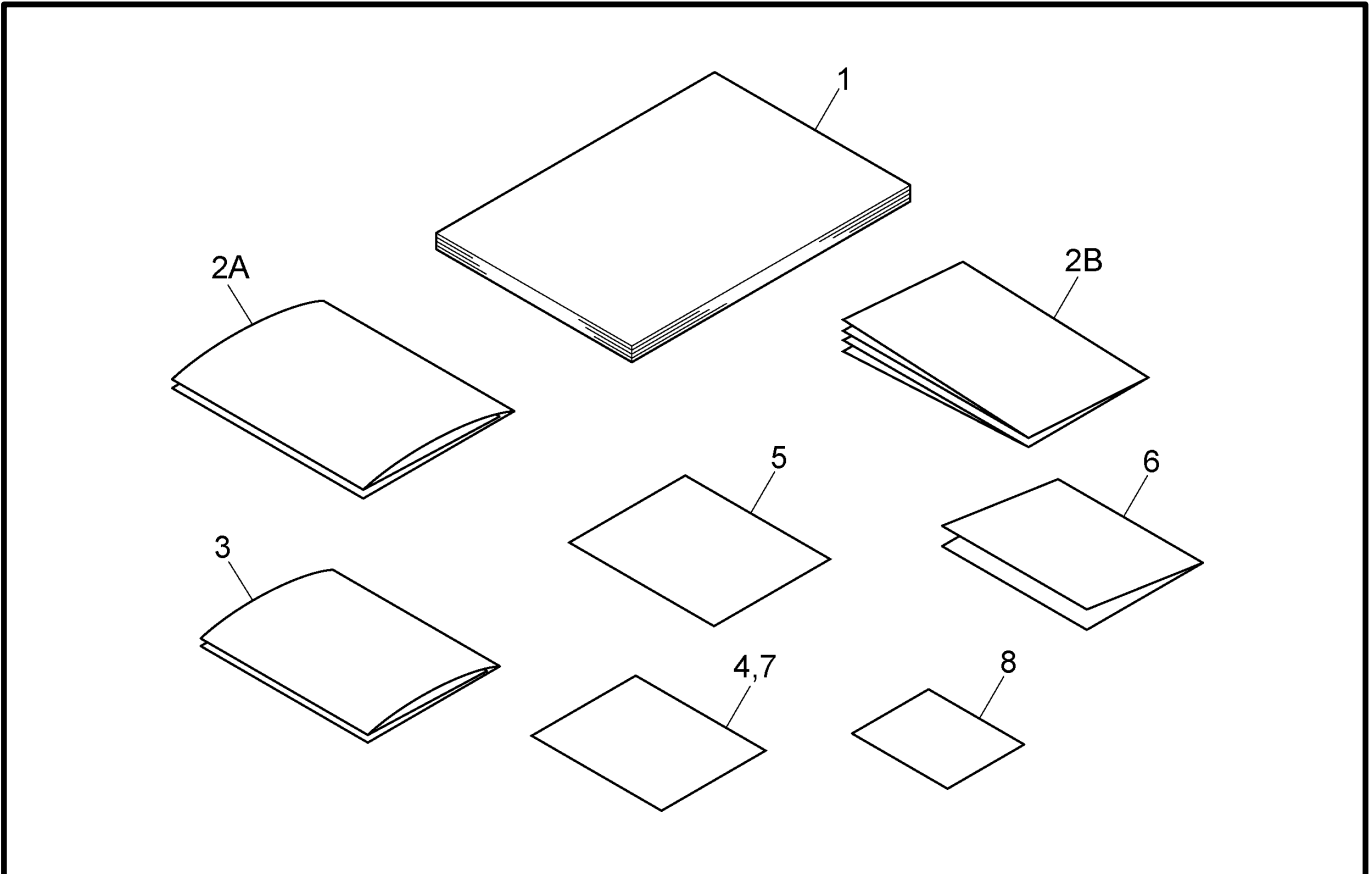

MODEL PT-1900/1910 8V2-325-920

6 . SENSORS

REF.NO.	SYMBOL	CODE	Q'TY	DESCRIPTION	REMARKS
1		LA5704001	1	SWITCH ASSY 2300	

MODEL PT-1900/1910 8V2-325-100

7 . PRINTED MATTER

REF.NO.	SYMBOL	CODE	Q'TY	DESCRIPTION	REMARKS
1		LA7771001		USER'S MANUAL 1900, USA.ENGLIS (USA) (PT-1900/1910)	
1		LA7772001		USER'S MANUAL 1900, CAN.ENGLIS (CAN) (PT-1900)	
1		LA7773001		USER'S MANUAL 1900, CAN.FRENCH (CAN) (PT-1900)	
1		LA7774001		USER'S MANUAL 1900, AUS (AUS) (PT-1900)	
2A	A	LA4059001		WARRANTY CARD US CH (USA) (PT-1900/1910)	
2B	B	UN8607001		WARRANTY CARD, CAN.E/F (CAN) (PT-1900)	
3		UN0838001		TAPE CATALOG US, ENG/CHINESE (USA) (PT-1900/1910)	
3		LA1188001		TAPE CATALOG CA 18 CHN (CAN) (PT-1900)	
3		LA2895001		TZ TAPE CATALOG, AUS CH (AUS) (PT-1900)	
4		LA1825001		ACCESSORY ORDER FORM, US (USA) (PT-1900/1910)	
5		LA7789001		UNPACKING INSTRUCTION 1900 (USA/CAN) (PT-1900/1910)	
6		LA7790001		APPLICATION CARD, 1900 US (USA) (PT-1900/1910)	
6		LA7981001		APPLICATION CARD, 1900 AUS (AUS) (PT-1900)	
7		LA7787001		LEGEND INSERTION 1900 (CAN) (PT-1900)	
8		LA7788001		LEGEND LABEL 1900 (CAN) (PT-1900)	

MODEL PT-1900/1910 8V2-325-920

8. PACKING MATERIALS

PT-1900(CAN)

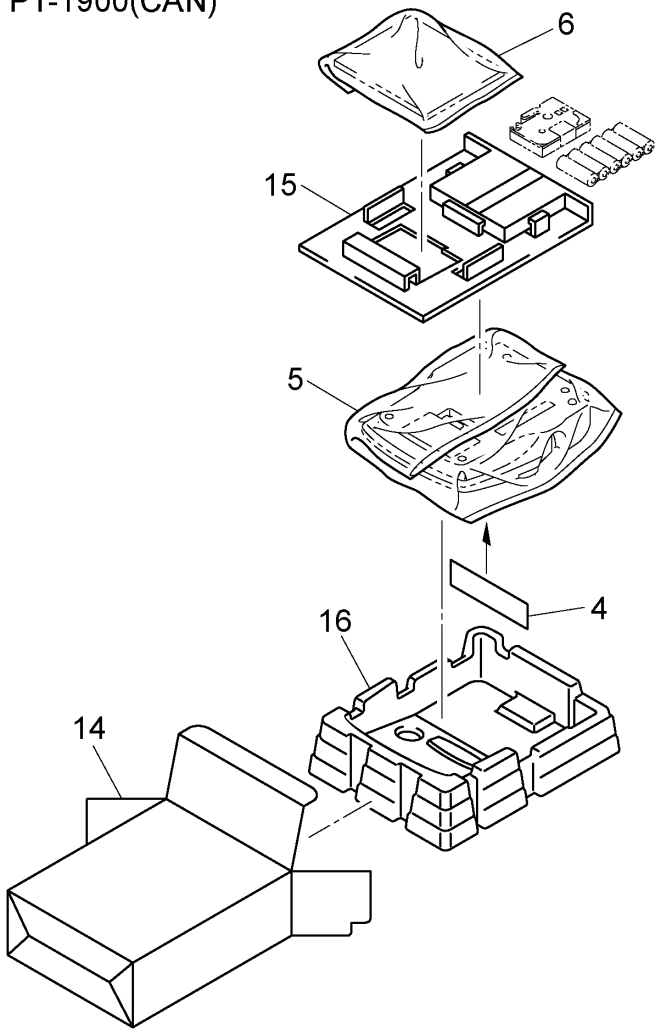

PT-1900(USA/AUS)

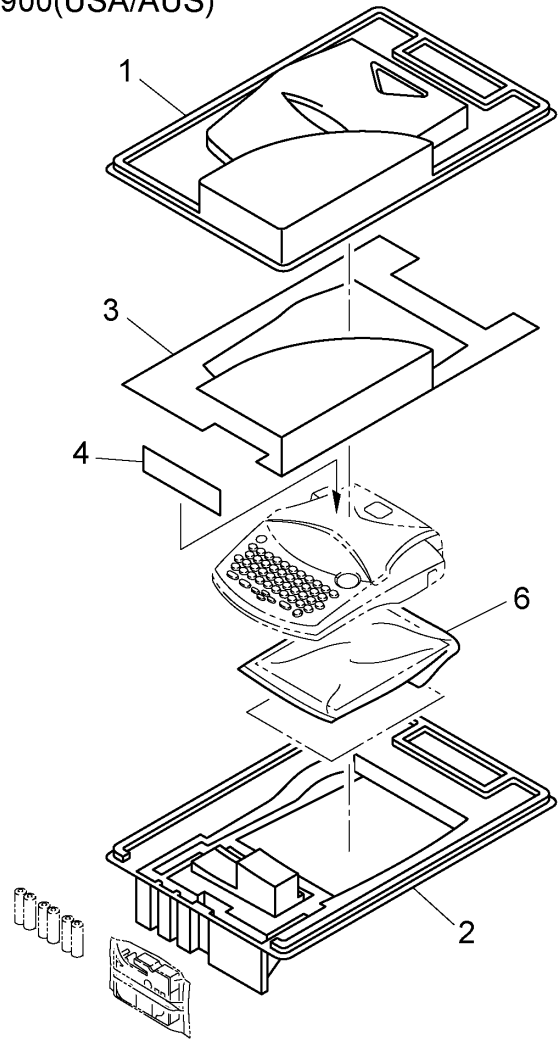

PT-1910(USA)

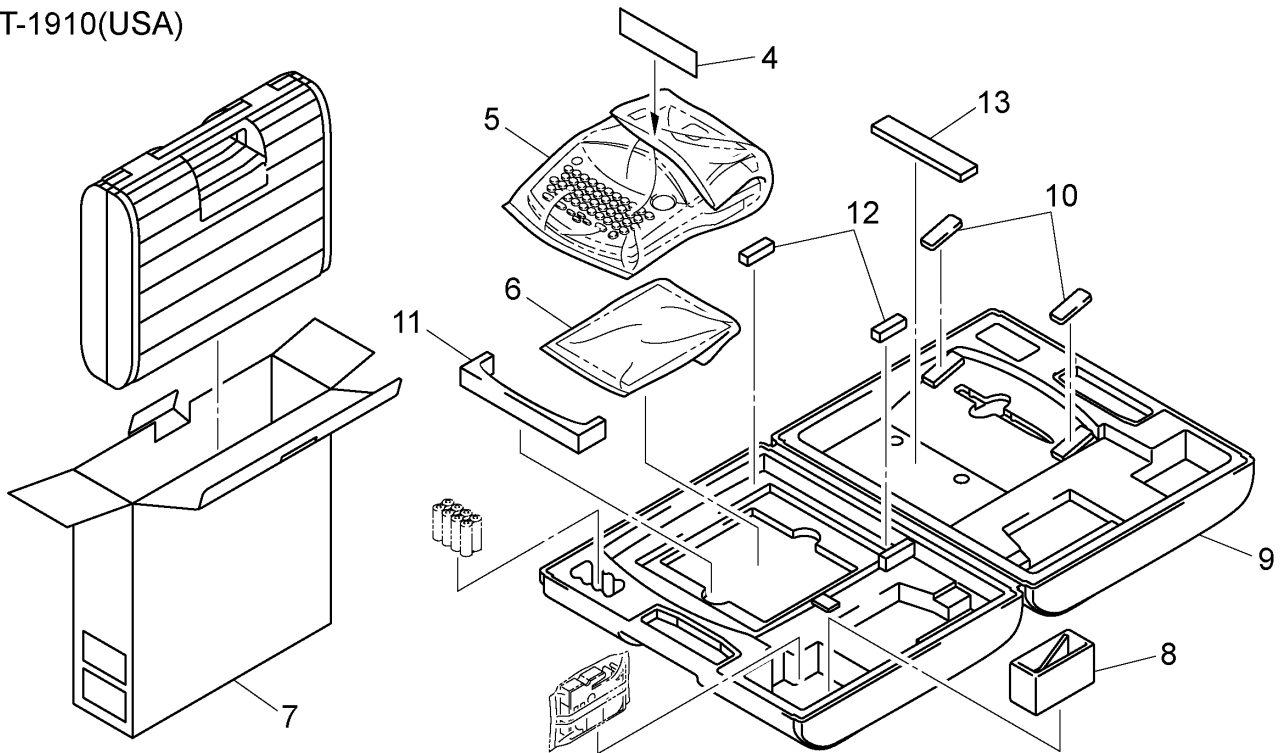

8 . PACKING MATERIALS

REF.NO.	CODE	Q'TY	DESCRIPTION	REMARKS
1	LA7793000	1	CLAM SHELL UPPER PT1900 (USA/AUS) (PT-1900)	
2	LA7794000	1	CLAM SHELL LOWER PT1900 (USA/AUS) (PT-1900)	
3	LA7795001	1	COMMERCIAL SHEET PT1900 US (USA) (PT-1900)	
3	LA7796001	1	COMMERCIAL SHEET PT1900 AUS (AUS) (PT-1900)	
4	LA6629000	1	PLATEN PROTECT PAD 2300	
5	LA0085001	1	BAG, 280X400H (BODY) (USA) (PT-1910)	
5	LA5168001	1	BAG, 280X410H (BODY) (CAN) (PT-1900)	
6	LA6867001	1	BAG, 215X360H (USER'S MANUAL)	
7	LA7799001	1	CARTON PT1910 US (USA) (PT-1910)	
8	LA0334001	1	CASSETTE SPACER 2410 (USA) (PT-1910)	
9	LA6057001	1	CARRYING CASE 2310 (USA) (PT-1910)	
10	LA6708000	2	PAD 2310 (USA) (PT-1910)	
11	LA6824000	1	PAD 1900 (USA) (PT-1910)	
12	LA6825000	2	PAD CC6994 (USA) (PT-1910)	
13	LA6826000	1	PAD 150X30 (USA) (PT-1910)	
14	LA7977001	1	CARTON 1900 CA (CAN) (PT-1900)	
15	LA7407000	1	PAD UPPER 1900 (CAN) (PT-1900)	
16	LA7408000	1	PAD LOWER 1900 (CAN) (PT-1900)	

MODEL PT-1900/1910 8V2-325-930

brother®

Apr., 2002
8V2041BE0
Printed in Japan