

brother®

TZ  
TAPE

# P-touch® 1900/1910

## USER'S GUIDE GUÍA DE USUARIO

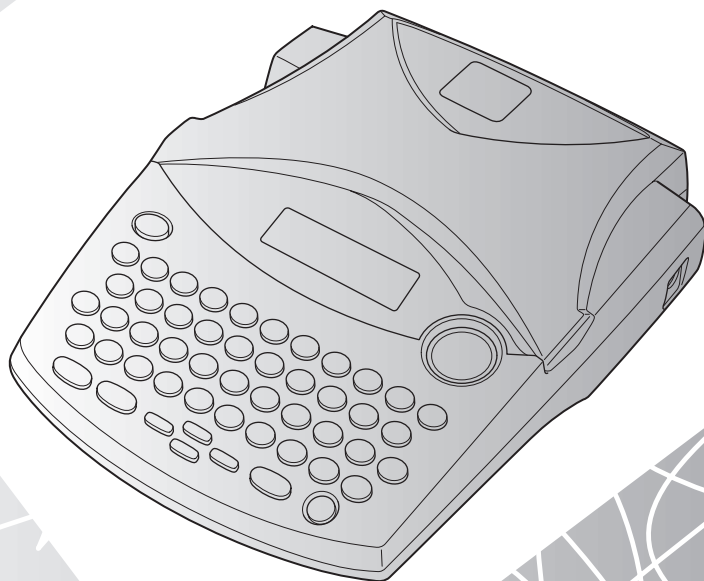

- Read this User's Guide before you start using your P-touch.
- Keep this User's Guide in a handy place for future reference.
- Antes de usar su equipo por primera vez, lea cuidadosamente esta guía de usuario.
- Guarde esta guía para futuras referencias.

## INTRODUCTION

Thank you for purchasing the P-touch 1900/1910!

Your new P-touch will allow you to create labels and stamps for any need. Its versatility enables you to design custom labels by choosing from a variety of frame designs and from many character sizes and styles. In addition, the four tape widths (1/4" (6 mm), 3/8" (9 mm), 1/2" (12 mm) and 3/4" (18 mm)) and variety of tape colors allow you to print personalized labels, useful for color-coded filing.

You no longer have to worry about urgent tasks that require professional printing. In the office, the factory, the lab and the home, the quality and performance of the P-touch 1900/1910 makes it an extremely practical machine.

Finally, as you may want to occasionally refer to this User's Guide, we suggest that you keep it in a handy place.

(The PT-1900 and the PT-1910 models are equipped with the same functions; however, the PT-1910 includes a carrying case and additional tape.)

### FCC NOTICE

**This equipment has been tested and found to comply with the limits for a Class B digital device, pursuant to Part 15 of the FCC Rules. These limits are designed to provide reasonable protection against harmful interference in a residential installation. This equipment generates, uses, and can radiate radio frequency energy and, if not installed and used in accordance with the instructions, may cause harmful interference to radio communications. However, there is no guarantee that interference will not occur in a particular installation. If this equipment does cause harmful interference to radio or television reception, which can be determined by turning the equipment off and on, the user is encouraged to try to correct the interference by one or more of the following measures:**

- Reorient or relocate the receiving antenna
- Increase the separation between the equipment and receiver.
- Connect the equipment into an outlet on a circuit different from that to which the receiver is connected.
- Consult the dealer or an experienced radio/TV technician for help.
- Changes or modifications not expressly approved by Brother Industries, Ltd. could void the user's authority to operate the equipment.

**Patent numbers and patent publication numbers which are related to this product are as below:**

USP4839742	USP4983058	USP5120147
USP4927278	USP5009530	
USP4976558	USP5069557	

## **Brother® 90 Days/One Year Limited Warranty and Replacement Service (For USA Only)**

This warranty gives you certain rights and you may also have other rights that may vary from state to state.

This warranty is given only to the original end-use purchaser (referred to in this warranty as "Original Purchaser") of the accompanying product (referred to in this warranty as "this Product").

### **What is covered:**

Brother warrants to only the Original Purchaser for 90 days from the date of original purchase by the Original Purchaser (referred to in this warranty as "90 Day Period") of the Product that there are no defects in the materials, workmanship or Year 2000 compliance of this Product. Provided the Original Purchaser informs Brother International Corporation ("Brother") of the need for Product service before the last day of the 90 Day Period, provided the Original Purchaser provides proof of the date of original purchase by the Original Purchaser, and provided this warranty is not void, Brother or its authorized service center will repair or (at Brother's option) replace this Product free of charge, but only to the extent such service is required due only to defective materials, workmanship or Year 2000 compliance. After the 90 Day Period, and until one year from date of original purchase by the Original Purchaser (referred to in this warranty as "Secondary Period") and provided this warranty is not void, Brother or its authorized service center will furnish, free of charge, a replacement part for the defective part of this Product. The Original Purchaser shall pay for all labor charges during the Secondary Period. The replacement of defective parts without charge during the Secondary Period does not include consumable and accessory items such as tapes, cutters, stamps, power adapters etc.

### **What is NOT covered:**

This warranty is VOID -- that is, this Product has no warranty -- if: (1) you did not purchase this Product from an authorized Brother reseller within the United States, (2) this Product has been serviced, modified or tampered with by anyone other than an Authorized Service Representative of Brother, (3) the serial number has been modified, defaced or removed from this Product, (4) this Product has been abused or damaged, (5) non Brother®-brand or non Brother

approved parts, supplies, or other accessories have been used with this Product.

### **What to do if you think your Product is defective:**

Call our Customer Service Hotline (listed below) or if you suspect a defect in materials or workmanship in this Product, you can report it to a Brother Authorized Service Center. During either the 90-Day Period or the Secondary Period (collectively referred to in this warranty as the "Warranty Period"), supply Brother's representative with a copy of your dated bill of sale showing that this Product was purchased within the United States. For the name of a Brother Authorized Service Center, call the Brother Automated Fax Back number or visit the Brother World Wide Web (listed below). After contacting the Brother Authorized Service Center, you may be required to deliver or send the Product properly packaged, freight prepaid, to the Authorized Service Center together with a photocopy of your bill of sale.

### **What Brother will do:**

Brother (or its Authorized Service Center) will evaluate your report of a possible defect to determine whether a defect exists, and if it does exist, Brother (or its Authorized Service Center) will repair or (at Brother's option) replace the Product with a product that performs the same functions and performs as well as the original Product. Brother reserves the right to supply refurbished or remanufactured replacement products provided that the replacement products conform to the manufacturer's specifications for new Products. The repaired or replacement product will be returned to you freight prepaid.

## **Brother® 90 Days/One Year Limited Warranty and Replacement Service (For USA Only)**

### **Replacement Service:**

Replacement service will expedite the exchange of your non-working Product with a refurbished or remanufactured product that conforms to the manufacturer's specifications for new Products. The refurbished or remanufactured Product you receive will be covered by the balance of the limited warranty period remaining on the original Product, plus an additional thirty (30) days. You will keep the replacement Product that is sent to you and must return (or be billed up to the cost of a new product) your original non-working product, which shall become the property of Brother. You must call Brother Customer Service and if the representative cannot correct the Product's malfunction over the telephone and you elect the Exchange Service, you must provide information pertaining to this Product and you must also provide a valid major credit card number. Your credit card will be charged up to the cost of a new Product if: (i) you do not return your original Product to Brother within five (5) business days; (ii) the malfunctions of your original Product are not covered by the limited warranty; (iii) the proper packaging instructions are not followed and has caused damage to the product; or (iv) the warranty period on your original Product has expired or has not been sufficiently validated with a copy of the proof of purchase (bill of sale). The Brother Customer Service Representative will ship the exchange Product with return instructions and prepaid return airbill. Follow the return instructions. You must return the original Product in the same shipping carton in which the exchanged Product was received and include a copy of proof of purchase (bill of sale). Retain your original accessory items and a copy of the return airbill, signed by the courier.

### **Limitations:**

Repair or replacement as described above is your sole and exclusive (that is, your only) remedy if this Product is defective. Brother is not responsible for damage to or loss of any equipment, media, programs or data related to the use of this Product. Except for that repair or replacement, Brother shall not be liable for any direct, indirect, incidental or consequential damages or specific relief. Because some states do not allow the exclusion or limitation of consequential or incidental damages, the above limitation may not apply to you.

THIS WARRANTY IS GIVEN IN LIEU OF ALL OTHER WARRANTIES, WRITTEN OR ORAL, WHETHER EXPRESSED BY AFFIRMATION, PROMISE, DESCRIPTION, DRAWING, MODEL OR SAMPLE. ANY AND ALL WARRANTIES OTHER THAN THIS ONE, WHETHER EXPRESS OR IMPLIED, INCLUDING IMPLIED WARRANTIES OF MERCHANTABILITY AND FITNESS FOR A PARTICULAR PURPOSE, ARE HEREBY DISCLAIMED.

This Limited Warranty is the only warranty that Brother is giving for this Product. It is the final expression and the exclusive and only statement of Brother's obligations to you. It replaces all other agreements and understandings that you may have with Brother or its representatives.

This Limited Warranty (and Brother's obligation to you) may not be changed in any way unless you and Brother sign the same piece of paper in which we (1) refer to this Product and your bill of sale date, (2) describe the change to this warranty and (3) agree to make that change.

## Important Information

Should you have questions, or need information about your Brother Product, we have a variety of support options for you to choose from:

### USA-Customer Service:

Customer Service

877-478-6824 (voice)

Customer Service

901-379-1210 (fax)

Automated Faxback

800-521-2846

World Wide Web

[www.brother.com](http://www.brother.com)

Supplies / Accessories

[www.brothermall.com](http://www.brothermall.com)

or 888-879-3232

### **BROTHER INTERNATIONAL CORPORATION**

**100 SOMERSET CORPORATE BLVD.**

**BRIDGEWATER, NEW JERSEY 08807-0911**

Please record your model and serial number and your date and location of Purchase below for your records. Keep this information with your proof of purchase (bill of sale) in case your Product is lost, stolen or requires service.

Model # \_\_\_\_\_

Serial # \_\_\_\_\_

Date of purchase: \_\_\_\_\_

Store where purchased: \_\_\_\_\_

Location of store: \_\_\_\_\_

**Important:** We recommend that you keep all original packing materials, in the event you ship this product.

# CONTENTS

## **Getting Started**

GENERAL DESCRIPTION .....	1
GENERAL PRECAUTIONS .....	3
BATTERIES .....	3
OPTIONAL AC ADAPTOR .....	4
TAPE CASSETTE .....	5
ATTACHING LABELS .....	6
PRINT HEAD & ROLLERS .....	7

## **For Your Information**

POWER KEY .....	8
CURSOR KEYS .....	8
CODE, ALT & SHIFT KEYS .....	9
SPACE KEY .....	12
RETURN KEY .....	12
TAB FUNCTION .....	13
DELETE KEY .....	15
LINE OUT FUNCTION .....	16
CLEAR FUNCTION .....	17
ACCENT FUNCTION .....	19
SYMBOL FUNCTION .....	20
AUTO FORMAT FUNCTION .....	22
STAMP FUNCTION .....	23
FONT FUNCTION .....	26
SIZE & WIDTH FUNCTIONS .....	27
STYLE FUNCTION .....	29
UNDERLINE FUNCTION .....	31
FRAME FUNCTION .....	32
TAPE MARGIN FUNCTION .....	33
HORIZONTAL ALIGNMENT FUNCTION .....	34
MIRROR PRINTING FUNCTION .....	35
LENGTH FUNCTION .....	36
AUTO CUT FUNCTION .....	38

PRINT KEY .....	39
FEED & CUT FUNCTION .....	40
NUMBERING FUNCTION .....	40
REPEAT PRINTING FUNCTION .....	42
MEMORY FUNCTIONS .....	43
TROUBLESHOOTING .....	47
ERROR MESSAGE LIST .....	48
SPECIFICATIONS .....	51
ACCESSORIES .....	52
INDEX .....	54
BROTHER CONTACT INFORMATION .....	56





# Getting Started

## GENERAL DESCRIPTION

### TOP VIEW

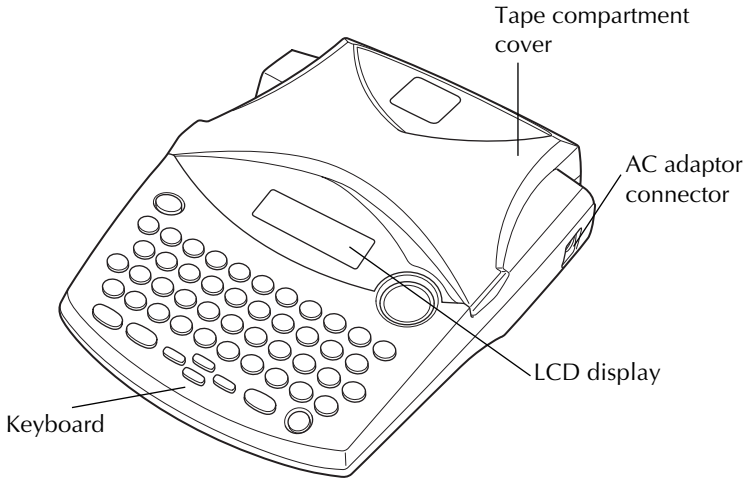

### BOTTOM VIEW

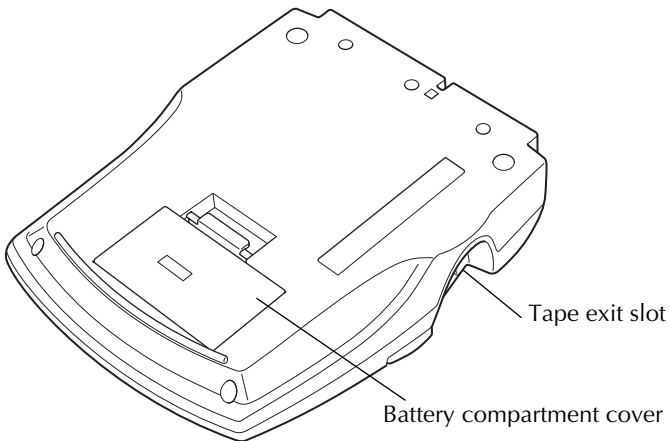

# KEYBOARD & LCD DISPLAY

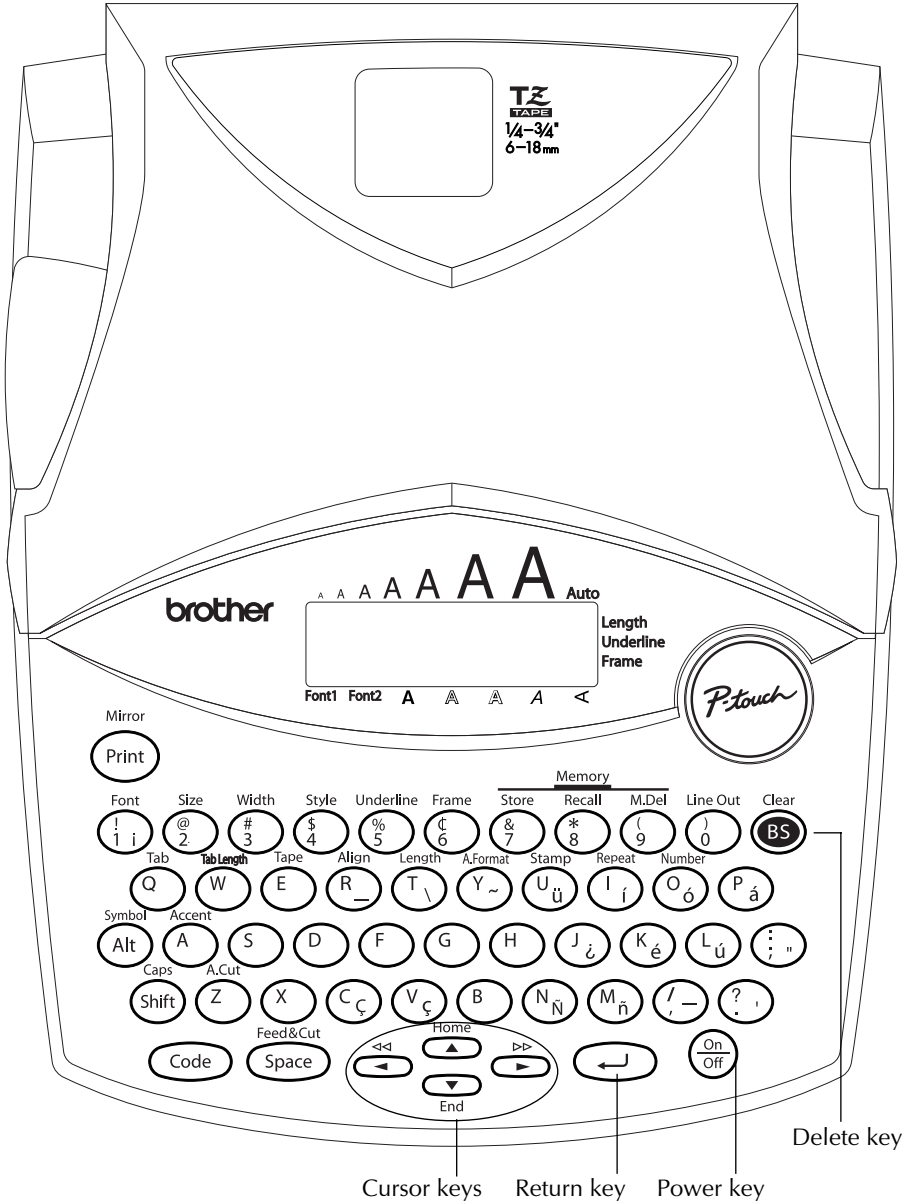

## GENERAL PRECAUTIONS

- **To avoid injuries, do not touch the cutter's edge.**
- Use only Brother TZ tapes with this machine to avoid damage. Do not use tapes that do not have the  mark. Brother cannot be held responsible for trouble or damage by the use of unauthorized supplies.
- Do not pull on the tape being fed from the P-touch. This may damage the tape cassette.
- Do not use the machine in dusty places, and keep it out of both direct sunlight and rain.
- Do not expose the machine to high temperatures or high humidity. Never leave it on the dashboard or in the back of your car.
- Do not leave any rubber or vinyl on the machine for an extended period of time. Doing so may cause staining.
- Do not clean the machine with alcohol or other organic solvents. Use a soft, dry cloth only.
- Do not put any foreign objects into or anything on the machine.
- Use only the AC adaptor (model AD-60) designed exclusively for this machine. Use of any other adaptor may void the warranty.
- Do not try to disassemble the AC adaptor.
- When the machine is not being used for a long period of time and it is not necessary to keep the text files stored in the memory, disconnect the AC adaptor, and remove the batteries to prevent them from leaking and damaging the machine.
- When the AC adaptor is connected, unplugging the adaptor from the electrical outlet before unplugging it from the machine can delete all text files in the memory, even if batteries are installed.
- **Use six AA alkaline batteries in this machine.**
- If the batteries are not installed with their positive and negative poles pointing in the correct direction, the batteries may leak, overheat or burst, or the print head may overheat.

## BATTERIES

This portable machine can be used anywhere by installing six (6) **AA alkaline batteries**. When you change the batteries, always replace all six at the same time.

### To change the batteries:

- 1 Remove the battery compartment cover on the back of the machine.
- 2 If batteries are already installed, remove them.
- 3 Insert six new AA alkaline batteries, making sure that their poles point in the correct direction.
- 4 Attach the battery compartment cover.

 *Be sure to insert the new batteries within five minutes of removing the old ones, otherwise the text shown in the display and any text files stored in the memory will be lost (unless the machine is plugged into an AC outlet with the AC adaptor).*

Remove the batteries and disconnect the AC adaptor if you do not intend to use this machine for an extended period of time. When the power is disconnected, all text shown in the display and stored in the memory will be lost.

If the batteries are not installed with their positive and negative poles pointing in the correct direction, the batteries may leak, overheat or burst, or the print head may overheat.

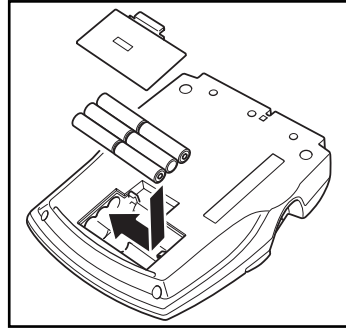
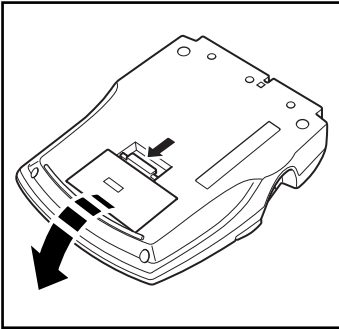

## OPTIONAL AC ADAPTOR

The AC adaptor (model AD-60) allows you to use this machine wherever there is an electrical outlet.

### To connect the optional AC adaptor:

- 1 Insert the plug on the adaptor cord into the connector marked DC IN 9.5V on the right side of the machine.
- 2 Insert the plug on the adaptor into the nearest standard electrical outlet.

 Only use the AC adaptor designed exclusively for this machine.

*Remove the batteries and disconnect the AC adaptor if you do not intend to use this machine for an extended period of time. When the power is disconnected, all text shown in the display and stored in the memory will be lost.*

*When the AC adaptor is connected, unplugging the adaptor from the electrical outlet before unplugging it from the machine can delete all text files in the memory, even if batteries are installed.*

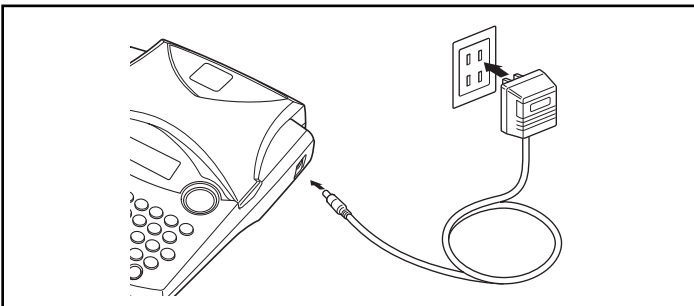

## TAPE CASSETTE

A single TZ tape cassette is supplied with this unit. However, since TZ tape cassettes are available for this machine in a wide variety of colors and sizes, it is possible to make distinctive color-coded and stylized labels.

In addition, this machine has been designed to allow you to change the tape cassettes quickly and easily.

### To change the tape cassette:

- 1 Lift open the tape compartment cover. The installed cassette is also released.
- 2 If a tape cassette is already installed, remove it by pulling it straight up.
- 3 If the ink ribbon in the tape cassette to be installed is loose, use your finger to wind the toothed wheel in the direction of the arrow on the cassette until there is no slack in the ribbon. Also, make sure that the end of the tape feeds under the tape guides.
  - ☞ *If you are using a new tape cassette provided with a stopper, be sure to remove the stopper.*
- 4 Insert the tape cassette firmly into the tape compartment, making sure that the entire back of the cassette touches the bottom of the compartment.
  - ☞ *When inserting the tape cassette, make sure that the inner ribbon does not catch on the corner of the metal guide.*
- 5 Close the compartment cover, and then turn on the machine, if it is off.
- 6 Hold down **Code** and press **Feed&Cut** **Space** once to advance the tape and remove any slack.

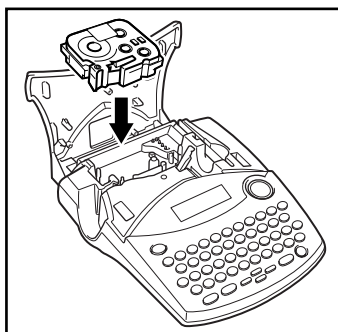
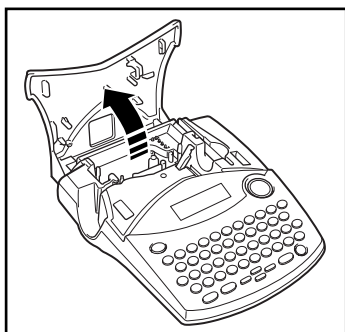

## ATTACHING LABELS

### LAMINATED TAPE

The enclosed stick enables you to easily remove the backing from labels printed on laminated tapes.

- 1 Hold the tape in your left hand, with the printed surface facing up, and hold the stick in your right hand.
- 2 Pass the tape halfway through the long narrow hole in the stick.
- 3 Turn the stick three-quarters of a turn towards you and pull the stick away from you as shown below.
- 4 Peel off the label backing.

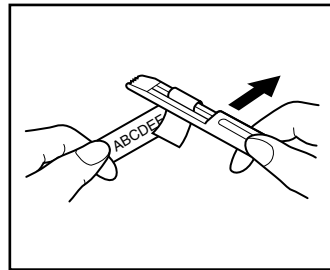
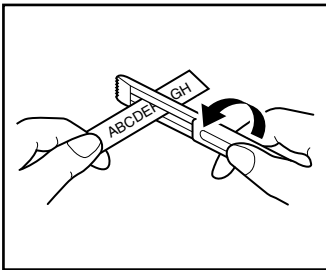
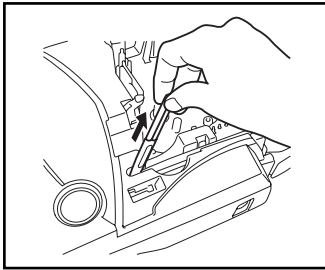

### FABRIC TAPE

Fabric tape is used to attach a piece of fabric printed with your text onto garments using an iron. After printing the text onto fabric tape and cutting off the label using scissors, place the label on an ironed garment at the location where you wish to attach it in such a way that the printed text can be read correctly. Cover the label with another piece of cloth and use an iron set to a medium-high temperature (320 to 356 °F (160 to 180 °C)) and press down firmly for 15 to 30 seconds. For more details, refer to the instructions included with the fabric tape cassette.

### STAMP TAPE

Refer to pages 23 through 25 for a detailed explanation on using the stamp tape to make stamps.

## PRINT HEAD & ROLLERS

Occasionally, specks of dust or dirt become attached to the machine's print head and rollers. This is particularly likely when you are using the unit outdoors or in a very dusty environment. If a section of the print head is covered with dust, a black horizontal streak may appear through the label text. Therefore, as with a tape recorder, the machine's head may need to be cleaned from time to time.

### To clean the print head and rollers:

- 1 Turn off the machine.
- 2 Open the tape compartment cover, and then remove the tape cassette if one is installed. The print head and rollers are located in the tape compartment.
- 3 **Print head:** Use a dry cotton swab to gently wipe the print head with an up-and-down motion.  
**Rollers:** Use a dry cotton swab to wipe each roller with an up-and-down motion while rotating them with your finger.
- 4 Install a tape cassette, close the tape compartment cover, and then try printing again.
- 5 If a black streak still appears in the label, repeat steps 3 and 4 using a cotton swab dipped in isopropyl (rubbing) alcohol.

If none of the above works, contact your service representative.

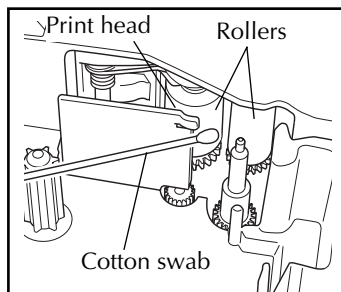
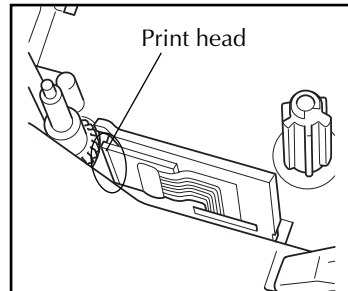
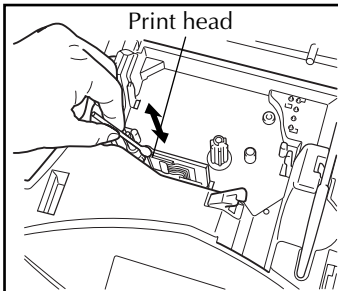

 The print head can be cleaned more easily if the optional print head cleaning cassette (TZ-CL4) is used.

# For Your Information

## POWER KEY

The **Power** key (  ) is located in the lower-right corner of the keyboard. If batteries have been installed or the machine has been plugged in using the optional AC adaptor, the previous session's information is displayed when the machine is turned on. This feature allows you to stop work on a label, turn off the machine, and return to it later without having to re-enter the text.

The machine will automatically turn off if no key is pressed within 5 minutes. The machine's internal memory stores the current session's information and displays it when you turn on the machine again.

### To turn on the machine:

- Press . The previous session's information appears in the LCD display.

### To turn off the machine:



- Press . The current session's information is stored in the internal memory.

## CURSOR KEYS

The machine's LCD display shows two rows of 9 characters; however, the text that you create can be up to 99 characters long. You can review and edit different parts of the text by moving the cursor backward and forward.

### LEFT CURSOR KEY

#### To move the cursor one character to the left:

- Press  once.  
 *If this key is pressed when the cursor is at the beginning of a line following another line, the cursor moves to the end of the previous line.*

#### To move the cursor several characters to the left:

- Hold down  until the cursor moves to the desired position.

#### To move the cursor to the beginning of the current line:

- Hold down  and press .



## RIGHT CURSOR KEY

**To move the cursor one character to the right:**

- Press  once.
  - ☞ *If this key is pressed when the cursor is at the end of a line followed by another line, the cursor moves to the beginning of the next line.*

**To move the cursor several characters to the right:**

- Hold down  until the cursor moves to the desired position.

**To move the cursor to the end of the current line:**

- Hold down  and press .

## UP CURSOR KEY

**To move the cursor up to the previous line:**

- Press  once.
  - ☞ *If the cursor is in the first line of text, it will move to the beginning of the line.*

**To move the cursor up several lines:**

- Hold down  until the cursor moves to the desired line.

**To move the cursor to the beginning of the entire text:**

- Hold down  and press .

## DOWN CURSOR KEY

**To move the cursor down to the following line:**

- Press  once.
  - ☞ *If the cursor is in the last line of text, it will move to the end of the line.*

**To move the cursor down several lines:**

- Hold down  until the cursor moves to the desired line.

**To move the cursor to the end of the entire text:**

- Hold down  and press .

## CODE, ALT & SHIFT KEYS

Most characters can be entered simply by pressing their keys. However, to use special functions or to enter capital letters, accented characters and some symbols, the following special keys are necessary.

## CODE KEY

**To use a function printed above a key:**

- Hold down  and press the key immediately below the desired function.

## EXAMPLE

To start the Symbol function:

- Hold down **Code** and press **Alt** once.

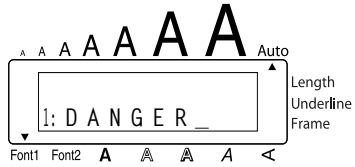

## ALT KEY

To type in characters printed in color on the right-hand side of the keys:

- Hold down **Alt** and press the key of the desired character written in color. The **Alt** indicator on the left side of the display comes on while **Alt** is held down.

## EXAMPLE

To type in “-”:

- Hold down **Alt** and press **/;-** once. The **Alt** indicator comes on while **Alt** is held down.

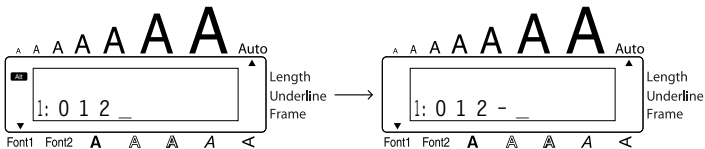

## SHIFT KEY

To type in an uppercase letter or a symbol printed in the top left-hand corner of a key:

- Hold down  and press the key of the desired letter or symbol.

### EXAMPLE

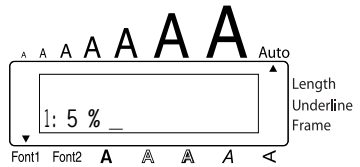
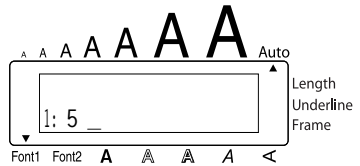

To type in “%”:

- Hold down  and press .





The **Caps** mode is similar to holding down . It allows you to type capital letters continuously.

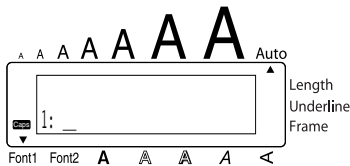

To type in many capital letters:

- 1 Hold down  and press . The **Caps** indicator on the left side of the display comes on.



- 2 Press the keys of the desired letters or symbols.
- 3 To exit **Caps** mode, hold down  and press . The **Caps** indicator goes off.

## SPACE KEY

The **Space** key (  ) lets you add blank spaces between characters in your text. It is different from the right cursor key (  ), which just moves the cursor without adding blank spaces.

**To add a space:**

- Press .

### EXAMPLE

**To add a space:**

- Press .

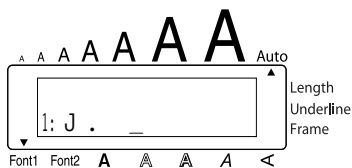

## RETURN KEY

As on a typewriter or word processor, this machine's **Return** key (  ) is used to end a line of text and start another one. When you have finished entering one line, press the return key to make a new line and move the cursor to it.

- ⓘ *The text can only contain a maximum of four lines. If you press  when four text lines already exist, the error message "4 LINE LIMIT!" will appear.*

Tape widths	Maximum number of lines that can be printed
1/4" (6 mm)	2
3/8" (9 mm)	2
1/2" (12 mm)	3
3/4" (18 mm)	4
Stamp 3/4" (18 mm)	3

The return key can also be used to select an item from a list (e.g., add a symbol or accented character to the text) or to apply a selected setting.

Some questions asking you to confirm a command may appear on the LCD display, especially when the function that you have chosen will delete or affect files. In these cases, pressing  is like answering "yes".

 To answer "no", press . Refer to DELETE KEY on page 15.

**To add a new line:**

- Press . The return mark ( ↵ ) appears to indicate the end of the line.

**To select an item from a list:**



- Press .

**To answer "yes":**

- Press .

## TAB FUNCTION

This function allows you to separate sections of a line of text by adding tabs. This enables you to create perfectly aligned columns without having to type in several spaces. All tabs have the same length and are measured from either the beginning of the line or the previous tab, if there is more than one. The tab length can be set between 0.0" and 11.8" (0.0 and 30.0 cm).

 The text cannot contain more than 50 tabs. If the maximum number of tabs has already been added to the text when  is held down and  is pressed, the error message "TAB LIMIT!" appears.

Part No.	Product	Price
8667	Printer	\$300
122960	Fax	\$100

**To set the tab length:**

- 1 Hold down **Code** and press **W** once. The current tab length is displayed.
- 2 Press **Home** or **End** until the desired length is displayed or use the number keys to type in the length.
  - ☞ To change the units (inches or centimeters) used to display the tab lengths, press **M<sub>n</sub>** until the desired units are displayed.
- 3 Press **←**.

**To add a tab:**

- Hold down **Code** and press **Q** once. The tab mark ( **T** ) appears in the text to indicate the position of the tab.
  - ☞ If the text in front of a tab extends past the point where the next section of text should start, the text will instead start at the following tab position. For example, if the tab length is set to 1.2" (3.0 cm) and the following text is typed in:

1: A B C **T** D E F **T** G H I ↓  
 2: J K L M N O P Q R S T **T** U

the label shown below will be printed.

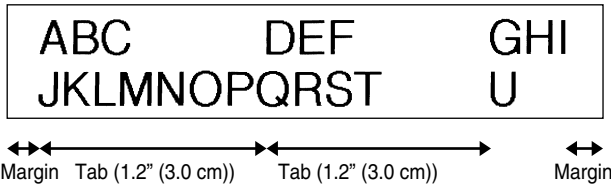



**EXAMPLE**

**To set the tab length to 1":**

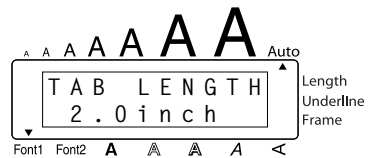
- 1 Hold down **Code** and press **W** once.





2 Press  until 1.0 is displayed.

3 Press .





### To add a tab:

● Hold down  and press  once.



## DELETE KEY





The **Delete** (backspace) key (  ) allows you to remove characters to the left of the cursor's current position. It differs from the left cursor key (  ), which only moves the cursor without deleting any characters.

The delete key can also be used to quit most functions and return to the previous display without changing the text.

Some questions asking you to confirm a command may appear on the LCD display, especially when the function that you have chosen will delete or affect files. In these cases, pressing  is like answering "no".

 To answer "yes", press . Refer to RETURN KEY on page 12.

### To delete one character:

1 Press , ,  or  to position the cursor below the character immediately to the right of the character that you wish to delete.

2 Press  once.

**To delete a sequence of characters:**

- 1 Press , , or to position the cursor below the character immediately to the right of the last character that you wish to delete.
- 2 Hold down until all of the characters that you wish to delete are deleted.

**To quit a function without changing your text:**

- Press to return to your text.

**To answer “no”:**

- Press .

## LINE OUT FUNCTION

With the **Line Out** function, you can easily remove an entire line of text.

**To delete a line of text:**

- 1 Press , , or to position the cursor within the line of text that you wish to delete.
- 2 Hold down and press once.  
 Each time is pressed while is held down, one line of text is deleted.

### EXAMPLE

**To delete “012-345-6789”:**

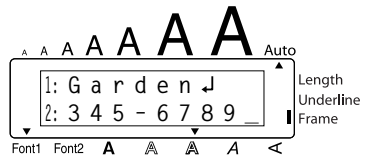

- Hold down and press once.





## CLEAR FUNCTION

When clearing the display before entering new text, the **Clear** function can be used to choose whether all of the text is erased and all format functions (**Font**, **Size**, **Width**, **Style**, **Underline**, **Frame**, **Tape margin**, **Alignment**, **Tab length**, **Mirror printing**, and **Length**) are returned to their default settings, or whether just the text is erased.

To delete all of the text and return all formats to their default settings:

- 1 Hold down **Code** and press **BS**.
- 2 Press **Home** or **End** until **TXT&FORMAT** is selected (flashing).  
 To return to the text without erasing anything, press **BS**.
- 3 Press **↵**.

### EXAMPLE

To clear the text and formats:

- 1 Hold down **Code** and press **BS**.

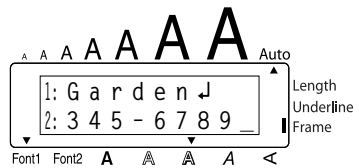

- 2 Press **Home** until **TXT&FORMAT** is flashing.

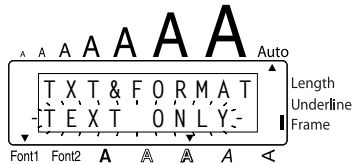

- 3 Press **↵**.

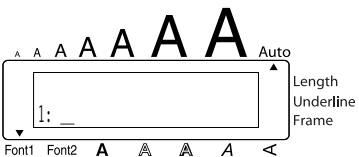
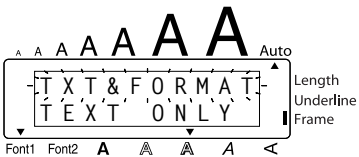

### To delete just the text:

- 1 Hold down **Code** and press **BS**.
- 2 Press **Home** or **End** until **TEXT ONLY** is selected (flashing).  
*To return to the text without erasing anything, press **BS**.*
- 3 Press **↵**.

### EXAMPLE

#### To clear just the text:

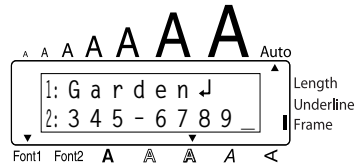

- 1 Hold down **Code** and press **BS**.

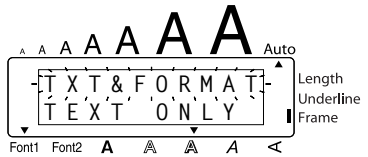

- 2 Press **End** until **TEXT ONLY** is flashing.

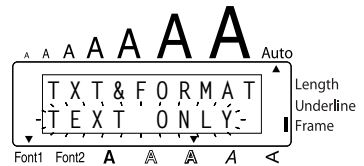

- 3 Press **↵**.

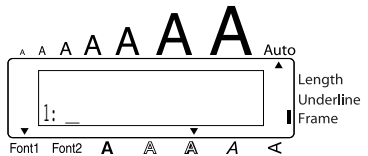













## ACCENT FUNCTION

The **Accent** function can also be used to add accented characters to your text. Many of these characters can also be typed in using the **Symbol** function.

The accented characters are grouped according to the capital or small letter that they are combined with. The following accented characters are available:

Letters	Accented characters	Letters	Accented characters
A	À Á Â Ã Ä Å Æ	i	í î ï
a	à á â ã ä å æ	N	Ñ
C	Ç	n	ñ
c	ç	O	Ó Ô Õ Ö
E	È É Ê Ë Ì	o	ó ô õ ö
e	è é ê ë ì	U	Ù Ú Û Ü
I	Í Î Ï	u	ù ú û ü

### To type in an accented character:

- ❶ Hold down  and press . The message "ACCENT a – u / A – U?" appears on the display.
- ❷ Press the key of the letter in the desired accented character.
  - ☞ To type a capital letter, hold down  (or hold down  and press  to turn on **Caps** mode) before pressing the letter key.
- ❸ Press  or  until the desired accented character appears enlarged within the frame in the middle of the display.
- ❹ Press . The accented character is added to the text.
  - ☞ To type in a series of accented characters, hold down  before pressing . Then, continue adding accented characters by selecting them as explained in steps ❷ and ❸, and holding down  while pressing . Press just  after selecting the last character in the series.

## EXAMPLE

To add the accented character “É”:

1 Hold down **Code** and press **A**.



2 Hold down **Shift** and press **E**.



3 Press **▶** until **É** appears in the frame.

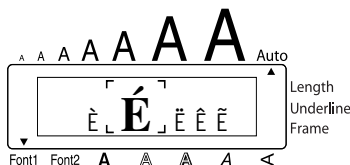

4 Press **↵**.



## SYMBOL FUNCTION

In addition to the letters, symbols and numerals on the key tops, there are 53 additional marks available with the **Symbol** function.

The following symbols are available:

Group	Symbol
1	Ü Æ æ Ã ã Ę ě Ő ő • ° ™
2	+ × ÷ = § ² ³ ² ³ 4 [ ]
3	↑ ↓ → ← ↵ ↶ Ⓞ Ⓢ ☎ 📁 📧 📧
4	☹ 🍷 🍂 ♿ 🏠 🎬 🌐 🌐 🗑️ 🗑️ 🗑️ 🗑️
5	☺ 🍷 🎵 ♥ ★

### To type in a symbol:

- Hold down **Code** and press **Alt**. A row of symbols appears in the display.
- Press **Home** or **End** to display different rows of symbols and press **Left Arrow** or **Right Arrow** until the desired symbol appears enlarged within the frame in the middle of the display.
- Press **Enter**. The symbol is added to the text.
 

*To type in a series of symbols, hold down **Code** before pressing **Enter**. Then, continue adding symbols by selecting them as explained in steps 2 and 3, and holding down **Code** while pressing **Enter**. Press just **Enter** after selecting the last symbol in the series.*

### EXAMPLE

#### To add the symbol “☹”:

- Hold down **Code** and press **Alt**.
- Press **Home** or **End** until the row containing “☹” appears, and then press **Left Arrow** or **Right Arrow** until “☹” appears in the frame.

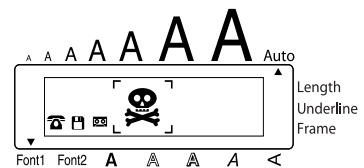

3 Press .





## AUTO FORMAT FUNCTION

With the **Auto Format** function, you can select from a variety of preset formats perfect for your specific need. This function automatically adjusts the label length, tape margins and horizontal alignment without changing the text or any other formats, allowing you to create labels faster and easier.

The following preset formats are available:

Auto Format Setting	Label Length Setting	Tape Margin Setting	Horizontal Alignment Setting
DEFAULT	OFF	FULL	LEFT
3.5" FLOPPY	2.8" (7.0 cm)	NARROW	CENTER
miniDV	1.7" (4.3 cm)	NARROW	CENTER
VHS SPINE	5.5" (14.0 cm)	NARROW	CENTER
VHS	3.0" (7.7 cm)	NARROW	CENTER
VCR8mm CASE	3.6" (9.2 cm)	NARROW	CENTER
VCR8mm	2.9" (7.3 cm)	NARROW	CENTER
VHS-C SPINE	1.8" (4.5 cm)	NARROW	CENTER
VHS-C	2.3" (5.8 cm)	NARROW	CENTER
AUDIO CASSETTE	3.5" (8.9 cm)	NARROW	CENTER
DAT CASSETTE	2.2" (5.6 cm)	NARROW	CENTER
MINI DISK	2.0" (5.2 cm)	NARROW	CENTER
ORGANIZER L	3.2" (8.2 cm)	NARROW	CENTER
ORGANIZER S	2.6" (6.5 cm)	NARROW	CENTER
FILE LONG	7.2" (18.3 cm)	NARROW	CENTER
FILE SHORT	3.7" (9.4 cm)	NARROW	CENTER

## To select a preset format:

- 1 Hold down **Code** and press **AFormat** once. The currently selected setting appears in the display.
- 2 Press **Home** or **End** to select the desired setting.  
 To return to default settings, press **Feed&Cut** **Space**.
- 3 Press **Enter** to apply the selected setting.  
 The **Length** indicator comes on if any setting other than **DEFAULT** is selected.

## EXAMPLE

### To select the AUDIO CASSETTE setting:

- 1 Hold down **Code** and press **AFormat**.



- 2 Press **Home** or **End** until the **AUDIO CASSETTE** setting is displayed.





- 3 Press **Enter**.

## STAMP FUNCTION

The **Stamp** function allows you to quickly and easily create your own stamp stencil films for customized stamps. After inserting a stamp film cassette, select this function to automatically center the text and adjust the tape length and margins to a perfect format for the pre-inked stamp film holders. Since the stamp holder is reusable, just make a new stamp stencil film and replace the one in the holder.

### To make a stamp:

- 1 Type in the text, and then insert a medium (3/4" (18-mm) wide) stamp film cassette.
- 2 Hold down **Code** and press **Stamp** once. The message "STAMP FORMAT?" appears in the display.

- 3 Press . The text is automatically formatted for the installed stamp: centered within the preset message area with the tape length and margins automatically adjusted.
- 4 Press  to cut the text out of the stamp stencil film.
- 5 After the stamp stencil film is cut off, remove the backing paper from the stamp stencil film and affix it to the ink pad of a stamp film holder.

**EXAMPLE**

**To cut a stamp:**

1 Enter the text and insert a stamp film cassette in the tape compartment.

2 Hold down  and press .

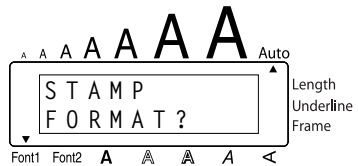

3 Press .

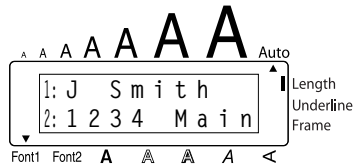

4 Press  to engrave the stamp stencil film, and then automatically cut it off.



**To affix a stamp:**

- 5 Remove the stamp frame from around the stamp film holder ink pad, one side at a time, and then remove the protective seal covering the ink pad and the backing paper from the stamp stencil film.
- 6 With the glossy side of the stamp stencil film upward, align one of its ends with the slit on the side of the stamp film holder.

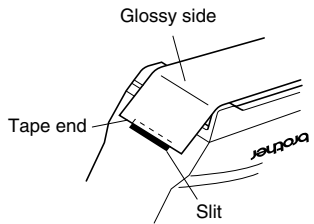



- 7 Hold the end of the stamp stencil film in place with your thumb, and then pass the tape through the guides while pulling it tight.

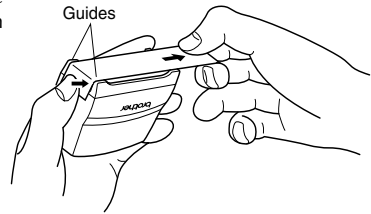

- 8 Fold the other end of the stamp stencil film over the other side of the stamp film holder and hold it in place with your finger.

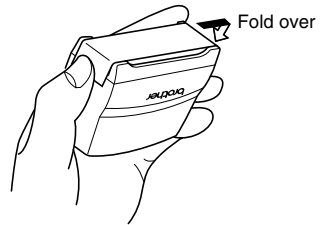

- 9 Fit the stamp frame over the stamp stencil film and push it into place.

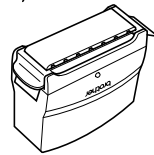
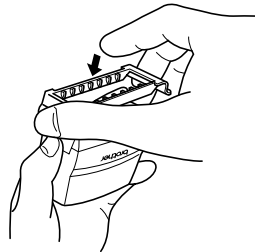

- 10 Insert the stamp film holder straight into its cap.  
**NOTE** Be sure that the stamp is correctly covered in order to prevent ink spills.

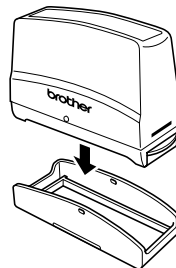

# FONT FUNCTION

With the **Font** function, you can choose one of two fonts for your text.  
The following font settings are available:

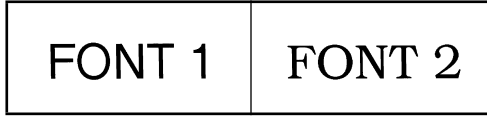

The default font setting is **FONT 1**. The font indicator at the bottom left of the display shows the currently selected font setting.

## To change the font setting:

- 1 While holding down **Code**, press **Font** once, and keep **Code** held down to display the current font setting.
- 2 While still holding down **Code**, continue pressing **Font** until the desired font setting is displayed.  
 *The current font setting is shown by the font indicator at the bottom left of the display.*
- 3 Release **Code** to apply the selected font setting to the entire text.

## EXAMPLE

### To select the FONT 2 font setting:

- 1 While holding down **Code**, press **Font** once, and keep **Code** held down.

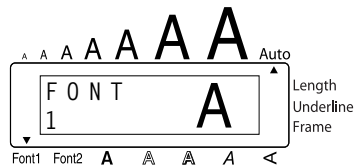

- 2 While still holding down **Code**, continue pressing **Font** until **FONT 2** is displayed.



- 3 Release **Code**.

## SIZE & WIDTH FUNCTIONS

The character size can be adjusted using both the **Size** and **Width** functions. Since the character size that can be used depends on the width of the tape, the following table shows the character sizes that can be used with each tape width.

Tape Widths	Sizes (in points)
1/4" (6 mm)	6, 9, 12
3/8" (9 mm)	6, 9, 12, 18
1/2" (12 mm)	6, 9, 12, 18, 24
3/4" (18 mm)	6, 9, 12, 18, 24, 36, 42

The default size setting is **AUTO** and the default width setting is **OFF**. The currently selected size setting is always shown by the indicator above the display.

With the **AUTO** size setting, the machine compares your text with the width of the installed tape and automatically adjusts the characters to the largest possible size. However, seven other point sizes are also available, and each can be printed with either of the two width settings.

 With the **AUTO** setting selected and 1/2" (12-mm) or 3/4" (18-mm) wide tape installed, text consisting of just one line of only uppercase letters (and no accented characters) will be printed with a character size slightly larger than a similar sentence also containing lowercase letters (i.e., 29 points for 1/2" (12-mm) wide tape and 52 points for 3/4" (18-mm) wide tape).

Size Setting (in points)	Width Setting Off	Width Setting On
6	ABC	ABC
9	ABC	ABC
12	ABC	ABC
18	ABC	ABC
24	ABC	ABC
36	ABC	ABC
42	ABC	ABC

### To change the size setting:

- 1 While holding down **Code**, press **@<sup>Size</sup>2** once, and keep **Code** held down to display the current size setting.
- 2 While still holding down **Code**, continue pressing **@<sup>Size</sup>2** until the desired size setting is displayed.  
 *The current size setting is shown by the size indicator at the top of the display.*
- 3 Release **Code** to apply the selected size setting to the entire text.

### EXAMPLE

#### To select the 24 point size setting:

- 1 While holding down **Code**, press **@<sup>Size</sup>2** once, and keep **Code** held down.

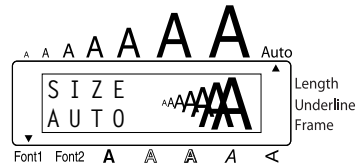

- 2 While still holding down **Code**, continue pressing **@<sup>Size</sup>2** until **24** is displayed.

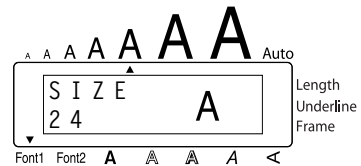

- 3 Release **Code**.

### To change the width setting:

- 1 While holding down **Code**, press **#<sup>Width</sup>3** once, and keep **Code** held down to display the current width setting.
- 2 While still holding down **Code**, continue pressing **#<sup>Width</sup>3** until the desired width setting is displayed.
- 3 Release **Code** to apply the selected width setting to the entire text.

## EXAMPLE

### To select the ON width setting:

- 1 While holding down **Code**, press **#3** once, and keep **Code** held down.



- 2 While still holding down **Code**, continue pressing **#3** until **ON** is displayed.



- 3 Release **Code**.

## STYLE FUNCTION

You can choose from nine different character styles to apply to your text.

- ☞ Characters printed using the smaller sizes may be difficult to read if certain style settings (e.g., **I+SHAD**) are selected.

The following style settings are available:

**NORMAL**, **BOLD**, **OUTLINE**, **SHADOW**, **ITALIC**, **I+BOLD** (italic & bold), **I+OUTL** (italic & outline), **I+SHAD** (italic & shadow), **VERT** (vertical)

The default style setting is **NORMAL**. The style indicator at the bottom of the display shows the current style setting when any setting other than **NORMAL** is selected.

Refer to *Reference* at the end of this section for samples of the available settings.

### To change the style setting:

- 1 While holding down **Code**, press **\$4** once, and keep **Code** held down to display the current style setting.
- 2 While still holding down **Code**, continue pressing **\$4** until the desired style setting is displayed.

- ☞ The current style setting is shown by the style indicator at the bottom of the display.

- 3 Release **Code** to apply the selected style setting to the entire text.

## EXAMPLE

To select the I+SHAD style setting:

- While holding down **Code**, press **Style** (S/4) once, and keep **Code** held down.



- While still holding down **Code**, continue pressing **Style** (S/4) until **I+SHAD** is displayed.

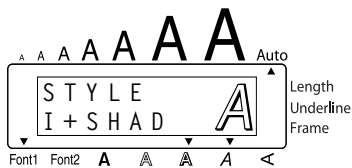

- Release **Code**.

## REFERENCE

Font Setting	Style Setting				
	NORMAL	BOLD	OUTLINE	SHADOW	ITALIC
FONT 1	abc	abc	abc	abc	abc
FONT 2	abc	abc	abc	abc	abc

Font Setting	Style Setting			
	I+BOLD	I+OUTL	I+SHAD	VERT
FONT 1	abc	abc	abc	abc
FONT 2	abc	abc	abc	abc

# UNDERLINE FUNCTION

You can emphasize your text by underlining it.

The default underline setting is **OFF**. When the **Underline** function is set to **ON**, the **Underline** indicator on the right side of the display comes on.

UNDL  
ON

ABC

(Sample)

## To turn the Underline function on or off:

- 1 While holding down (Code), press <sup>Underline</sup> (% 5) once, and keep (Code) held down to display the current underline setting.
  - 2 While still holding down (Code), continue pressing <sup>Underline</sup> (% 5) until the desired underline setting is displayed.
-  The **Underline** indicator comes on when the **ON** setting is selected.
- 3 Release (Code) to apply the selected underline setting to the entire text.

## EXAMPLE

### To select the ON underline setting:

- 1 While holding down (Code), press <sup>Underline</sup> (% 5) once, and keep (Code) held down.
- 2 While still holding down <sup>Underline</sup> (% 5), continue pressing (Code) until **ON** is displayed.
- 3 Release (Code).

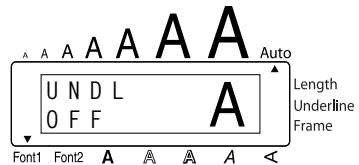

## FRAME FUNCTION

With the **Frame** function, you can choose from various frames and highlights to design a more decorative or emphasized label.

The default setting is **OFF**; however, the following five settings are also available.

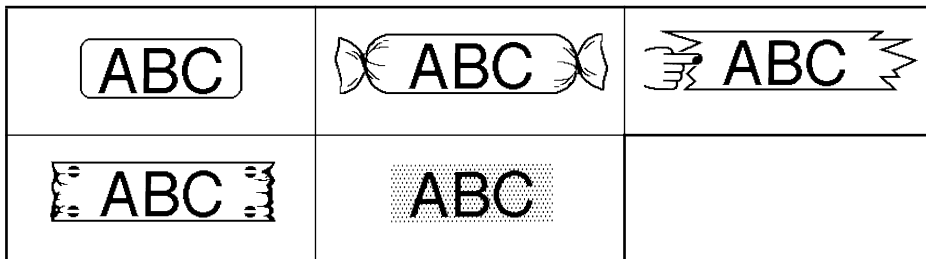

When any setting other than **OFF** is selected, the **Frame** indicator on the right side of the display comes on.

### To change the frame setting:

- 1 While holding down **Code**, press **Frame** (F6) once, and keep **Code** held down to display the current frame setting.
- 2 While still holding down **Code**, continue pressing **Frame** (F6) until the desired frame setting is displayed.

The **Frame** indicator comes on when any setting other than **OFF** is selected.

- 3 Release **Code** to apply the selected frame setting to the entire text.

### EXAMPLE

#### To select the candy frame setting:

- 1 While holding down **Code**, press **Frame** (F6) once, and keep **Code** held down.





## EXAMPLE

- 2 While still holding down **Code**, continue pressing **Frame** until the candy frame is displayed.

- 3 Release **Code**.

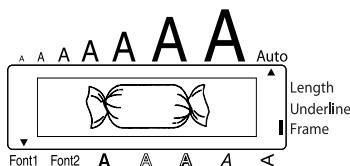

## TAPE MARGIN FUNCTION

The **Tape margin** function allows you to adjust the size of the margins on the left and right sides of your text.

The default tape margin setting is **FULL**; however, three other settings are also available.

### FULL

(1" (24 mm) margins)

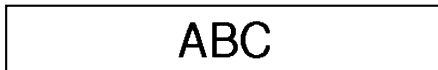

### NONE

(5/64" (2 mm) margins)

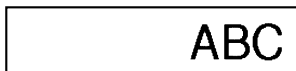

### NARROW

(1/6" (4 mm) margins)

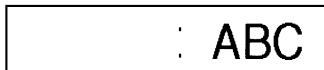

### HALF

(1/2" (12 mm) margins)

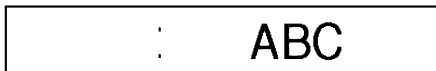

 When a setting other than **FULL** is selected, extra tape is fed out before printing starts.

## To change the tape margin setting:

- 1 While holding down **Code**, press **E** once, and keep **Code** held down to display the current tape margin setting.
- 2 While still holding down **Code**, continue pressing **E** until the desired tape margin setting is displayed.
- 3 Release **Code** to apply the selected tape margin setting to the entire text.

### EXAMPLE

#### To select the HALF tape margin setting:

- 1 While holding down **Code**, press **E** once, and keep **Code** held down.
- 2 While still holding down **Code**, continue pressing **E** until **HALF** is displayed.
- 3 Release **Code**.

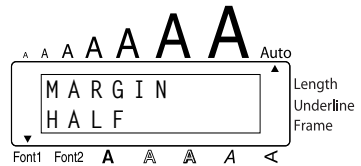

## HORIZONTAL ALIGNMENT FUNCTION

You can choose to align the text in one of three ways. In addition, if the **Length** function was used to set the length of the label, the text will align within the label according to the selected horizontal alignment setting.

The default setting is **LEFT**; however, two other settings are also available.

**LEFT**

AB
CDE
FG

**RIGHT**

AB
CDE
FG

**CENTER**

AB
CDE
FG

### To change the horizontal alignment setting:

- 1 While holding down **Code**, press **Align R** once, and keep **Code** held down to display the current horizontal alignment setting.
- 2 While still holding down **Code**, continue pressing **Align R** until the desired horizontal alignment setting is displayed.
- 3 Release **Code** to apply the selected horizontal alignment setting to the entire text.

### EXAMPLE

#### To select the **RIGHT** horizontal alignment setting:

- 1 While holding down **Code**, press **Align R** once, and keep **Code** held down.
- 2 While still holding down **Code**, continue pressing **Align R** until **RIGHT** is displayed.
- 3 Release **Code**.

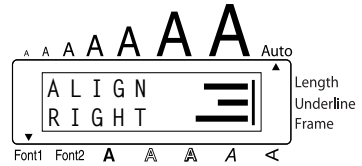
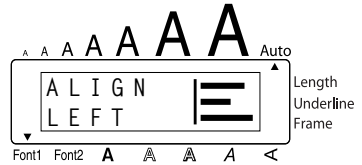

## MIRROR PRINTING FUNCTION

This function prints your label so that the text can be read from the adhesive side of the tape. If mirror-printed labels are attached to glass or some other transparent material, they can be read correctly from the opposite side.

When using the **Mirror printing** function, the text should be printed on clear tape.

The default mirror printing setting is **OFF**.

ON



### To turn the mirror printing setting on or off:

- 1 While holding down **Code**, press **Print** once, and keep **Code** held down to display the current mirror printing setting.
- 2 While still holding down **Code**, continue pressing **Print** until the desired mirror printing setting is displayed.
- 3 Release **Code** to apply the selected mirror printing setting to the entire text.

### EXAMPLE

#### To select the ON mirror printing setting:

- 1 While holding down **Code**, press **Print** once, and keep **Code** held down.
- 2 While still holding down **Code**, continue pressing **Print** until **ON** is displayed.
- 3 Release **Code**.

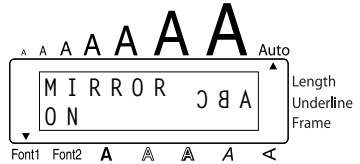
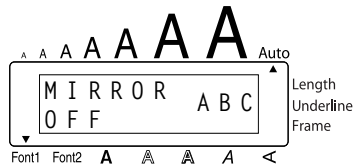

## LENGTH FUNCTION

Although the length of the printed label automatically adjusts to fit the length of the entered text, there may be times when you will want to make a label with a specific length. The **Length** function allows you to set the label length between 1.6" and 11.8" (4.0 cm and 30.0 cm).

The default length setting is **OFF**. When the **Length** function is set to **ON**, the **Length** indicator on the right side of the display comes on.

**To turn the Length function on or off:**

- 1 While holding down **Code**, press **T**<sub>Length</sub> once, and keep **Code** held down to display the current length of the label (the text and both margins). Then the display will show the current label length setting (**ON** or **OFF**).
- 2 While still holding down **Code**, continue pressing **T**<sub>Length</sub> until the desired label length setting is displayed.
  - ☞ The **Length** indicator comes on when **ON** is selected.
- 3 Release **Code**. If **ON** was selected, the current label length setting is displayed.
- 4 Press **Home** (▲) or **End** (▼) to select the desired length or use the number keys to enter a length.
  - ☞ To change the units (inches or centimeters) used to display the label length, press **M**<sub>n</sub> until the desired units are displayed.
  - To change the length in 1" (1.0-cm) steps, hold down either **Home** (▲) or **End** (▼), and then release the key when the desired setting is displayed.
- 5 Press **↵**.

**EXAMPLE**

**To select a label length of 5":**

- 1 While holding down **Code**, press **T**<sub>Length</sub> once, and keep **Code** held down.

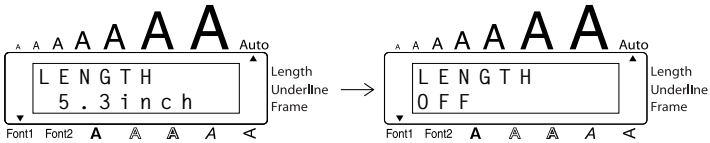

- 2 While still holding down **Code**, continue pressing **T**<sub>Length</sub> until **ON** is displayed.



- 3 Release **Code**.





4 Press  until **5.0 inch** is displayed.









5 Press .

## AUTO CUT FUNCTION

The **Auto cut** function allows you to set whether or not the machine will automatically cut each label after it is printed. Turn on the **Auto cut** function before starting to print in order to cut the labels automatically after printing them.



 After printing a label with the **Auto cut** function set to **OFF**, hold down  and press  once to feed the tape, then cut it.

**To turn the Auto cut function on or off:**

- 1 While holding down , press  once, and keep  held down to display the current auto cut setting.
- 2 While still holding down , continue pressing  until the desired auto cut setting is displayed.
- 3 Release  to apply the selected auto cut setting.

### EXAMPLE

**To turn the Auto cut function on:**

- 1 While holding down , press  once, and keep  held down.

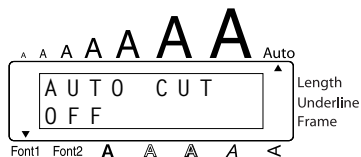

2 While still holding down **Code**, continue pressing

**Z** until **ON** is displayed.

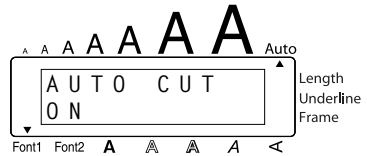

3 Release **Code**.

## PRINT KEY

After you have entered your text and chosen the desired format settings, you are ready to print.

If the **Auto cut** function is set to **ON**, the label will automatically be cut after it is printed.

### To print a label:

- Press **Print** once. The message “COPIES” followed by the number of the label being printed is displayed.

If the selected character size is too large for the width of the installed tape cassette, the message “CHR SIZE AUTO?” appears. To allow the text size to automatically be adjusted, press **Print** or **←**. To stop the text size from being changed, press **BS**.

## EXAMPLE

### To print and cut a label:



- Press **Print** once.



## FEED & CUT FUNCTION

The **Feed & Cut** function is used to feed out 1" (24 mm) of tape and automatically cut it off. For example, after printing with the **Auto cut** function set to **OFF** or when printing has been interrupted.

















**To feed and cut off 1" (24 mm) of tape:**

- Hold down  and press  once. 1" (24 mm) of tape is fed out and cut off.

## NUMBERING FUNCTION

This function can be used to print many copies of the same text while increasing a certain number in the text by 1 after each label is printed.

**To use the Numbering function:**

- 1 Press , ,  or  to position the cursor below the number that you wish to increase.
- 2 Hold down  and press . The message "NUMBER UNTIL" appears in the display with the current setting.
  -  To cancel the **Numbering** function at any time, hold down  and press  (or press just ).
- 3 Use the number keys to type in the last number to be printed.
  -  The last number to be printed can also be selected by pressing  or . A number lower than the one that was selected cannot be entered.
- 4 Press  (or ) to begin printing the labels. The number of each copy is displayed while it is being printed.
  -  If the **Tape margin** function is set to any setting other than **NONE**, a cutting guide (:) is printed between each label so the tape can be cut to the correct size.



## EXAMPLE

### To print three labels with numbers 1, 2 and 3:

- 1 Position the cursor below "1".



- 2 Hold down **Code** and press **06**.



- 3 Press **#3**.



- 4 Press **Mirror/Print** (or **↶**).

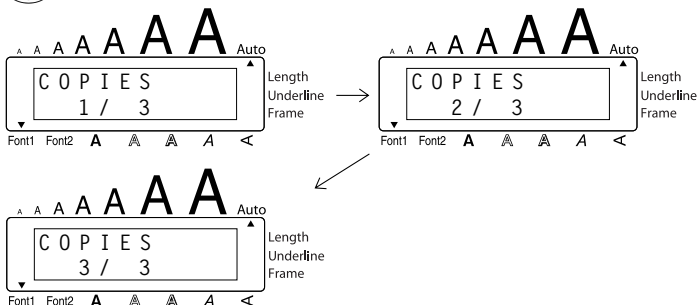

 If the **Tape margin** function is set to any setting other than **NONE**, a cutting guide (:) is printed between each label so the tape can be cut to the correct size.



# REPEAT PRINTING FUNCTION

This function allows you to print up to 9 copies of the same text.

## To use the Repeat printing function:

- 1 Hold down **Code** and press **Repeat** (1 j). The message “COPIES” appears in the display with the default setting 1, which will need to be changed, as necessary.
  - ☞ To cancel the **Repeat printing** function at any time, hold down **Code** and press **Repeat** (1 j) (or press just **Clear** (BS)).
- 2 Press **Home** (▲) or **End** (▼) until the desired number of copies is displayed, or use the number keys to type in the number.
- 3 Press **Print** (Mirror) (Print) (or ←) to begin printing the labels. The number of each copy is displayed, while it is being printed.
  - ☞ If the **Tape margin** function is set to any setting other than **NONE**, a cutting guide (:) is printed between each label so the tape can be cut to the correct size.

## EXAMPLE

### To print three copies of a label:

- 1 Hold down **Code** and press **Repeat** (1 j).
- 2 Press **Width** (# 3).

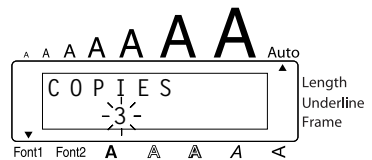
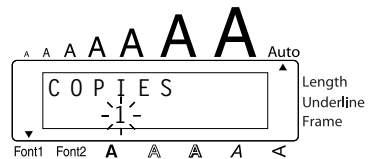

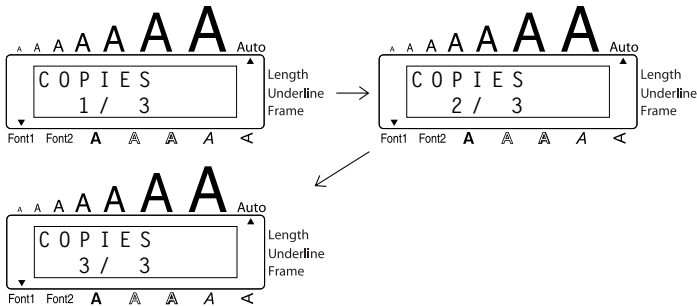

3 Press  (or ).



 If the **Tape margin** function is set to any setting other than **NONE**, a cutting guide (:) is printed between each label so the tape can be cut to the correct size.



## MEMORY FUNCTIONS

You can use the **Memory** to store your most frequently used text files. The text remains in the memory, along with its formatting, even after all characters are removed from the display using the **Clear** function (holding down  and pressing .



When each file is stored, it is given a number to make recalling it easier. Up to 10 text files or approximately 300 characters can be stored in the memory. (A single text file can have a maximum of 91 characters.)

Since a copy of the stored text file is recalled when the **Recall** function is used, the text can be edited or printed without changing the originally stored file. When a file is no longer needed or more space is necessary, the **Memory delete** function can be used to delete it.

 When inserting new batteries, be sure to insert the new ones within five minutes of removing the old ones, otherwise any text files stored in the memory will be lost (unless the machine is plugged into an electrical outlet with the AC adaptor).

### STORING TEXT

**To store a text file:**

- 1 Hold down  and press . The message "STORE" appears on the display with the currently selected file number.

To quit the **Store** function without storing the text, hold down and press (or press just ).

2 Press a number key (or press or ) to select the file number where you wish to store the text.

3 Press . The text is stored under the selected file number and the text previously shown in the display reappears.

If a file is already stored under the selected file number, the message “OVERWRITE?” appears in the display and you must decide whether or not to overwrite it (delete it from the memory and store the new one).

If the maximum number of characters has already been stored, the error message “MEMORY FULL!” appears in the display. If this occurs, an existing text file must be deleted before the new one can be stored.

### To overwrite the stored file with the new one:

● Press to delete the previously stored file and store the new one under the selected number.

To go back and choose another file number without overwriting the text file, press and then select a different file number.

## RECALLING TEXT

### To recall a text file:

1 Hold down and press . The message “RECALL” appears on the display with the file number and beginning of the most recently stored or recalled text.

To quit the **Recall** function without recalling text, hold down and press (or press just ).

2 Press a number key (or press or ) to select the file number containing the text that you wish to recall. The text stored under the selected file number is shown.

To see other parts of the selected text file, press or .

To display the text stored under other file numbers, press or , or the key of a different file number.

3 Press . Any text previously entered in the display is erased and the text stored under the selected file number is recalled into the display.

## DELETING A FILE

### To delete a text file:

1 Hold down and press . The message “CLEAR” appears on the display with the file number and beginning of the most recently stored or recalled text.

 To cancel the **Memory delete** function without deleting the text file, hold down **Code** and press **M.Del** (9) (or press just **Clear** (BS)).

2 Press a number key (or press **Home** (▲) or **End** (▼)) to select the file number containing the text that you wish to delete. The text stored under the selected file number is shown.

 To see other parts of the selected text file, press **<<** or **>>**.

To display the text stored under other file numbers, press **Home** (▲) or **End** (▼), or the key of a different file number.

3 Press **↵**. The message “OK TO CLEAR?” appears.

 To go back and select a different text file, press **Clear** (BS).

4 Press **↵** to delete the text file that was selected.

### EXAMPLE

#### To store text under file number 4:

1 Hold down **Code** and press **Store** (8/7).



2 Press **Style** (5/4).



3 Press **↵**.

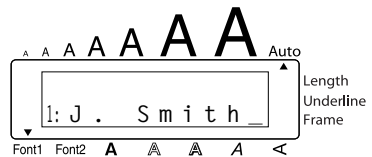

**To recall the text from file number 1:**

1 Hold down **Code** and press **Recall** <sup>\*8</sup>.

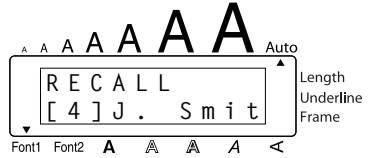

2 Press **Font** <sup>1</sup> **i**.



3 Press **↵**.



**To delete the text stored under file number 4:**

1 Hold down **Code** and press **M.Del** <sup>9</sup>.

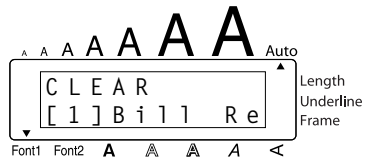

2 Press **Style** <sup>5</sup> **4**.

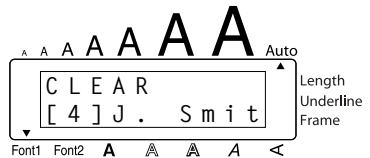

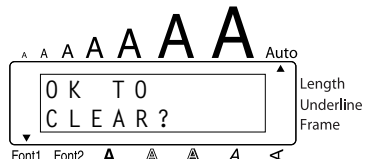

3 Press **↵**.













4 Press **↵**.





## TROUBLESHOOTING



Problem	Remedy
1. The display stays blank after you have turned on the machine.	<ul style="list-style-type: none"> <li>• Check that the AC adaptor is connected correctly.</li> <li>• If you are using alkaline batteries, check that they are correctly inserted.</li> <li>• If the batteries are low, replace them with new ones.</li> </ul>
2. The machine does not print or the printed characters are blurred.	<ul style="list-style-type: none"> <li>• Check that the tape cassette has been inserted properly.</li> <li>• If the tape cassette is empty, replace it with a new one.</li> <li>• Make sure that the tape compartment cover has been closed.</li> </ul>
3. The text files that you stored in the memory are no longer there.	<ul style="list-style-type: none"> <li>• If the batteries are low, replace them with new ones.</li> </ul>
4. The printed characters are not formed properly.	<ul style="list-style-type: none"> <li>• If you are using alkaline batteries, they may be low. Try using the AC adaptor or replace the batteries with new ones.</li> </ul>
5. A blank horizontal line appears through the printed label.	<ul style="list-style-type: none"> <li>• Clean the print head as explained on page 7.</li> </ul>
6. Striped tape appears.	<ul style="list-style-type: none"> <li>• You have reached the end of the tape. Replace the tape cassette with a new one.</li> </ul>
7. The machine has “locked up” (i.e., nothing happens when a key is pressed).	<ul style="list-style-type: none"> <li>• Turn off the machine, and then while holding down  and , turn the machine back on. The text and formats in the display and all text files stored in the memory are erased.</li> </ul>

## ERROR MESSAGE LIST

Error Message	Cause	Remedy
<b>4 LINE LIMIT!</b>	This message appears if four lines already exist when you press  .	Limit the number of lines to four.
<b>BATTERIES WEAK!</b>	This message appears when the installed alkaline batteries become weak.	Replace the batteries or use the AC adaptor.
<b>BUFFER EMPTY!</b>	<ul style="list-style-type: none"> <li>This message appears if you hold down  and press , but no text has been entered in the display.</li> </ul>	<ul style="list-style-type: none"> <li>Enter some text before starting this function.</li> </ul>
	<ul style="list-style-type: none"> <li>This message appears if you try to print, but no text has been entered in the display.</li> </ul>	<ul style="list-style-type: none"> <li>Enter text before printing.</li> </ul>
<b>BUFFER FULL!</b>	This message appears if you try to enter a character, symbol, return or space after the maximum number of characters has already been entered.	Delete some existing text so that more text can be entered.
<b>CAN'T HERE!</b>	This message appears if the cursor is at the end of the text when you hold down  and press  .	Move the cursor below a number before holding down  and pressing  .
<b>CHANGE ADAPTOR!</b>	This message appears if a high-voltage adaptor is being used.	Remove the high-voltage adaptor and connect the adaptor designed exclusively for this machine.
<b>CUTTER ERROR!</b>	This message appears if the tape cutter is closed when you try to print or feed the tape.	Turn the P-touch off, then on again.
<b>INVAL. CHRS!</b>	This message appears if the cursor is not below a number when you hold down  and press  .	Move the cursor below a number before holding down  and pressing  .



Error Message	Cause	Remedy
<b>LENGTH LIMIT!</b>	<ul style="list-style-type: none"> <li>This message appears if the text is longer than 3' 3 1/3" (1 meter) when you try to print.</li> </ul>	<ul style="list-style-type: none"> <li>Shorten the text to less than 3' 3 1/3" (1 meter) before trying to print.</li> </ul>
	<ul style="list-style-type: none"> <li>This message appears if the <b>Length</b> function is used to set a label length that is less than 1.6" (4.0 cm) or more than 11.8" (30.0 cm).</li> </ul>	<ul style="list-style-type: none"> <li>Set the label length between 1.6" (4.0 cm) and 11.8" (30.0 cm).</li> </ul>
	<ul style="list-style-type: none"> <li>This message appears if the <b>Tab Length</b> function is used to set a tab length that is more than 11.8" (30.0 cm).</li> </ul>	<ul style="list-style-type: none"> <li>Set the tab length so that it is less than 11.8" (30.0 cm).</li> </ul>
<b>LINE LIMIT!</b>	This message appears if the number of lines in the text is greater than the maximum number of lines possible for the installed tape.	Reduce the number of lines or install a tape of greater width.
<b>MEMORY FULL!</b>	This message appears if you try to store a text file after the maximum number of characters has already been stored in the memory.	Delete an unwanted file to make room for the new one.
<b>NO FILES!</b>	This message appears if you try to recall or delete a text file from the memory when none are stored.	Store a text file first.
<b>NO TAPE!</b>	This message appears if you try to print a label or feed the tape when no tape cassette is installed.	Install a tape cassette and try again.
<b>REPLACE BATTERIES!</b>	This message appears if the installed alkaline batteries are about to run out.	Replace the batteries or use the AC adaptor.
<b>ROM PROBLEM!</b>	This message appears if there is a problem with the machine's read only memory.	Turn off the machine, and then while holding down  and  , turn the machine back on. Contact your service representative.

Error Message	Cause	Remedy
<b>TAB LIMIT!</b>	This message appears if the maximum number of tabs has already been added to the text when you hold down  and press  .	Limit the number of tabs in the text to 50.
<b>TEXT TOO HIGH!</b>	This message appears if the size of the text is larger than the width of the installed tape.	Reduce the size of the characters or install a wider tape.
<b>TEXT TOO LONG!</b>	This message appears if the length of the text is longer than the label length that has been set using the <b>Length</b> function.	Delete some of the text, reduce the character width or increase the set label length.

SHOULD YOU ENCOUNTER ANY PROBLEMS WITH YOUR PRODUCT,  
**PLEASE DO NOT RETURN YOUR  
PRODUCT TO THE STORE!**

After referring to this User's Guide, if you still need assistance, refer to the Brother Contact information in this guide.

# SPECIFICATIONS

## HARDWARE

- Input Device:** Keyboard - 51 keys
- LCD:** 10 characters × 2 lines  
20 indicators (including **Alt** and **Caps**)
- Print Tape:** Pressure-sensitive, Adhesive-based  
26' 3" (8 m) long  
Five widths available:  
1/4" (6 mm)  
3/8" (9 mm)  
1/2" (12 mm)  
3/4" (18 mm)
- Power Supply:** Six AA alkaline batteries (AM3, LR6) or optional AC adaptor (model AD-60)  
Auto power-off if no key is pressed for 5 minutes
- Print Head:** 112 dot / 180 dpi
- Dimensions:** 7 1/8" (W) × 9 5/32" (D) × 2 1/8" (H)  
(181 × 232.5 × 61.4 mm)
- Weight:** 0.8 lbs (363.6 g) (without a tape cassette and batteries installed)

## SOFTWARE

- Buffer Size:** Maximum 91 characters  
Maximum four lines
- Memory Size:** Approx. 300 characters
- Character Size:** Seven sizes (6, 9, 12, 18, 24, 36 and 42 points) + 52 point (one line of capital letters only on 3/4" (18-mm) wide tape)  
All are available in normal and wide widths  
Availability depends on tape width.
- Print Styles:** Normal, Bold, Outline, Shadow  
(each can be combined with Italic), and Vertical

## IMPORTANT WARRANTY INFORMATION

Thank you for purchasing this Brother product.  
We hope that you will enjoy using it. We suggest you keep all packing and other materials.  
Consult your product's warranty for details.

## ACCESSORIES

- **Supplies**

Obtain tape cassettes from your nearest authorized dealer.

Use only Brother TZ tapes with this machine. **Brother cannot be held responsible for trouble caused by the use of unauthorized supplies.** Do not use tapes that do not have the  mark.

Stock No.	Description	QTY/ PACKAGE	PRICE**
3/4" (18-mm) wide laminated tapes			
TZ-141	Black characters on clear adhesive	1	\$18.99
TZ-145	White characters on clear adhesive	1	\$20.99
TZ-241	Black characters on white adhesive	1	\$20.99
TZ-242	Red characters on white adhesive	1	\$20.99
TZ-243	Blue characters on white adhesive	1	\$20.99
TZ-344	Gold characters on black adhesive	1	\$23.99
TZ-345	White characters on black adhesive	1	\$23.99
TZ-441	Black characters on red adhesive	1	\$20.99
TZ-541	Black characters on blue adhesive	1	\$20.99
TZ-545	White characters on blue adhesive	1	\$23.99
TZ-641	Black characters on yellow adhesive	1	\$20.99
TZ-741	Black characters on green adhesive	1	\$20.99
*TZ-B41	Black characters on fluorescent orange adhesive	1	\$24.99
TZ-M41	Black characters on clear (matte) adhesive	1	\$20.99
TZ-WB41	Black characters on Bugs Bunny adhesive	1	\$23.99
TZ-WT41	Black characters on Taz adhesive	1	\$23.99
TZ-WS41	Black characters on Tweety & Sylvester adhesive	1	\$23.99
TZ-S141	Industrial (strong adhesive) black characters on clear adhesive	1	\$21.99
TZ-S241	Industrial (strong adhesive) black characters on white adhesive	1	\$21.99
1/2" (12-mm) wide laminated tapes			
TZ-131	Black characters on clear adhesive	1	\$16.99
TZ-231	Black characters on white adhesive	1	\$17.99
TZ-232	Red characters on white adhesive	1	\$17.99
TZ-334	Gold characters on black adhesive	1	\$20.99
TZ-335	White characters on black adhesive	1	\$20.99
TZ-631	Black characters on yellow adhesive	1	\$17.99
TZ-S131	Industrial (strong adhesive) black characters on clear adhesive	1	\$18.99
TZ-S231	Industrial (strong adhesive) black characters on white adhesive	1	\$18.99

\* 16.4 ft. long

<b>Stock No.</b>	<b>Description</b>	<b>QTY/ PACKAGE</b>	<b>PRICE**</b>
3/8" (9-mm) wide laminated tapes			
TZ-121	Black characters on clear adhesive	1	\$14.99
TZ-221	Black characters on white adhesive	1	\$16.99
TZ-325	White characters on black adhesive	1	\$18.99
TZ-421	Black characters on red adhesive	1	\$16.99
TZ-S121	Industrial (strong adhesive) black characters on clear adhesive	1	\$17.99
TZ-S221	Industrial (strong adhesive) black characters on white adhesive	1	\$17.99
1/4" (6-mm) wide laminated tapes			
TZ-111	Black characters on clear adhesive	1	\$12.99
TZ-211	Black characters on white adhesive	1	\$14.99
TZ-315	White characters on black adhesive	1	\$17.99
TZ-S111	Industrial (strong adhesive) black characters on clear adhesive	1	\$15.99
TZ-S211	Industrial (strong adhesive) black characters on white adhesive	1	\$15.99

Special tapes

<b>Stock No.</b>	<b>Description</b>	<b>QTY/ PACKAGE</b>	<b>PRICE**</b>
TZ-SE4	Black characters on 3/4" (18 mm) security adhesive	1	\$29.99
TZ-FA3	Blue characters on 1/2" (12 mm) fabric tape	1	\$24.99

Stamp kit

<b>Stock No.</b>	<b>Description</b>	<b>QTY/ PACKAGE</b>	<b>PRICE**</b>
SK-MB	Stamp-making kit for Medium stamp with black ink	1	\$37.99
SH-MB	Additional stamper for Medium stamp with black ink	1	\$24.99

Options

<b>Stock No.</b>	<b>Description</b>	<b>QTY/ PACKAGE</b>	<b>PRICE**</b>
TZ-CL4	Head cleaner	1	\$20.99
AD-60	AC Adaptor	1	\$24.99
6994	Protective carrying case	1	\$29.99

- For purchasing accessories on the Internet, please visit our website:  
<http://www.brothermall.com>

\*\* Prices and availability of accessories subject to change without notice.

# INDEX

- A**  
AC adaptor ..... 4  
Accented characters ..... 19  
Adding  
    spaces ..... 12  
    tabs ..... 14  
Aligning ..... 34  
Alt key ..... 10  
Automatic formatting ..... 22  
Automatic tape-cutting ..... 38
- B**  
Backing label ..... 6  
Backspace key ..... 15  
Batteries ..... 3
- C**  
Capital letters ..... 11  
Caps mode ..... 11  
Cleaning  
    machine ..... 3  
    print head ..... 7  
    rollers ..... 7  
Clearing  
    text and formats ..... 17  
    text only ..... 18  
Code key ..... 9  
Confirming ..... 13  
Cursor keys ..... 8
- D**  
Deleting  
    characters ..... 15  
    text and formats ..... 17  
    text lines ..... 16  
    text only ..... 18  
Deleting stored files ..... 44
- E**  
Entering  
    accented characters ..... 10, 19  
    capital letters ..... 11  
    spaces ..... 12  
    symbols ..... 10, 11, 20  
    tabs ..... 14  
Error messages ..... 48
- F**  
Fabric tape ..... 6  
Feeding & cutting ..... 40  
Fonts ..... 26  
Frames ..... 32
- I**  
Incrementing ..... 40
- K**  
Keyboard ..... 2
- L**  
Label length ..... 36  
Laminated tape ..... 6
- M**  
Margins ..... 33  
Memory ..... 43  
Mirror printing ..... 35  
Multiple copies ..... 42
- N**  
New lines ..... 12  
Numbering function ..... 40
- O**  
Overwriting stored files ..... 44

<b>P</b>		<b>T</b>	
Power .....	8	Tab length .....	14
Preset formatting .....	22	Tabs .....	13
Print head .....	7	Tape cassettes .....	5
Printing .....	39	Tape length .....	36
<b>R</b>		Text	
Recalling stored files .....	44	alignment .....	34
Repeat printing function .....	42	framing .....	32
Return key .....	12	margins .....	33
<b>S</b>		size .....	28
Shift key .....	11	style .....	29
Size .....	28	underlining .....	31
Spaces .....	12	width .....	28
Specifications .....	51	Text lines .....	12
Stamp tape .....	6	Troubleshooting .....	47
Stamps .....	23	<b>U</b>	
Storing files .....	43	Underlining .....	31
Style .....	29	Uppercase letters .....	11
Symbols .....	20	<b>W</b>	
		Width .....	28

## BROTHER CONTACT INFORMATION

---

### Service Center Locations

---

If you need a local service center, please call 1-800-284-HELP (4357) to locate the authorized service center closest to you.

Note: Be sure to call the Service Center before your visit.

Service centers do not provide operational assistance. See "Operational Assistance".

---

### Operational Assistance

---

For technical and operational assistance you may call Brother Customer Service at: Voice 1-877-4-PTouch, or Fax 1-901-379-1210

---

### Assistance on the Internet

---

For product information and downloading the latest drivers: <http://www.brother.com>  
For purchasing accessories and certain Brother products: <http://www.brothermall.com>

---

### Accessories and Supplies

---

To order Brother accessories or supplies by Visa, MasterCard, Discover or American Express, you may call toll free 1-888-879-3232, or complete the order form in your user's guide and fax both sides of the form to 1-800-947-1445.

For purchasing accessories on the Internet: <http://www.brothermall.com>

To order by mail or pay by check, please complete the accessory order form and mail it along with payment to:

Brother International Corporation  
Attn: Consumer Accessory Division  
P.O. Box 341332  
Bartlett, TN 38133-1332

---

### Fax-Back System

---

Brother Customer Service has installed an easy-to-use Fax-Back System so you can get instant answers to common technical questions and product information for all Brother products. This system is available 24 hours a day, 7 days a week. You can use the system to send the information to any fax machine, not just the one you are calling from.

Please call 1-800-521-2846 and follow the voice prompts to receive faxed instructions on how to use the system and an index of Fax-Back subjects.



# P-TOUCH ACCESSORY ORDER FORM

Dear Customer:

This order form is provided for your convenience should your retailer not stock the item(s) needed. To order by mail, send this completed form along with proper payment to the address below OR credit card holders: call toll-free 1-888-879-3232, fax completed order form to 1-800-947-1445, or visit our web site at <http://www.brothermall.com>. Please refer to the Accessories listing in your User's Guide for stock no. and price.

Stock No.	Description	Price	Quantity	Total
<b>Subtotal</b>				

Name: \_\_\_\_\_ **Accessory Subtotal:** \$ \_\_\_\_\_  
Address: \_\_\_\_\_ AZ, CA, CO, CT, FL, GA, IL, LA,  
City: \_\_\_\_\_ MA, MD, MI, MN, MO, NC, NJ,  
State/Zip: \_\_\_\_\_ NV, NY, OH, PA, TN, TX, VA, WA  
Daytime Phone: \_\_\_\_\_ residents add applicable sales tax \$ \_\_\_\_\_

### SEND ORDER FORM TO:

Brother International Corp.  
Attn: Consumer Accessory Div.  
P.O. Box 341332  
Bartlett, TN38184-1332

### Shipping/Handling Options

Please choose one:

- Standard (\$5.00)
- 2nd day air freight (\$8.75) Mandatory for all deliveries outside of the continental U.S. (Alaska, Hawaii, Puerto Rico, Virgin Islands & Canada)
- All other overseas orders (\$25.00) \$ \_\_\_\_\_

**TOTAL DUE (US dollars)** \$ \_\_\_\_\_

### Method of payment (Check one)

Visa  MasterCard  Discover  American Express  Check/Money Order

Account Number \_\_\_\_\_  
Expiration Date \_\_\_\_\_  
Signature \_\_\_\_\_

\* Prices, taxes and shipping / handling charges subject to change without notice.



## **BROTHER CONTACT INFORMATION**

---

### **Service Center Locations**

---

If you need a local service center, please call 1-800-284-HELP (4357) to locate the authorized service center closest to you.

Note: Be sure to call the Service Center before your visit.

Service centers do not provide operational assistance. See "Operational Assistance".

---

### **Operational Assistance**

---

For technical and operational assistance you may call Brother Customer Service at: Voice 1-877-4-PTouch, or Fax 1-901-379-1210

---

### **Assistance on the Internet**

---

For product information and downloading the latest drivers: <http://www.brother.com>  
For purchasing accessories and certain Brother products: <http://www.brothermall.com>

---

### **Accessories and Supplies**

---

To order Brother accessories or supplies by Visa, MasterCard, Discover or American Express, you may call toll free 1-888-879-3232, or complete the order form in your user's guide and fax both sides of the form to 1-800-947-1445.

For purchasing accessories on the Internet: <http://www.brothermall.com>

To order by mail or pay by check, please complete the accessory order form and mail it along with payment to:

Brother International Corporation  
Attn: Consumer Accessory Division  
P.O. Box 341332  
Bartlett, TN 38133-1332

---

### **Fax-Back System**

---

Brother Customer Service has installed an easy-to-use Fax-Back System so you can get instant answers to common technical questions and product information for all Brother products. This system is available 24 hours a day, 7 days a week. You can use the system to send the information to any fax machine, not just the one you are calling from.

Please call 1-800-521-2846 and follow the voice prompts to receive faxed instructions on how to use the system and an index of Fax-Back subjects.

# P-TOUCH ACCESSORY ORDER FORM

Dear Customer:

This order form is provided for your convenience should your retailer not stock the item(s) needed. To order by mail, send this completed form along with proper payment to the address below OR credit card holders: call toll-free 1-888-879-3232, fax completed order form to 1-800-947-1445, or visit our web site at <http://www.brothermall.com>. Please refer to the Accessories listing in your User's Guide for stock no. and price.

Stock No.	Description	Price	Quantity	Total
<b>Subtotal</b>				

Name: \_\_\_\_\_  
 Address: \_\_\_\_\_  
 City: \_\_\_\_\_  
 State/Zip: \_\_\_\_\_  
 Daytime Phone: \_\_\_\_\_

**Accessory Subtotal:** \$ \_\_\_\_\_  
 AZ, CA, CO, CT, FL, GA, IL, LA,  
 MA, MD, MI, MN, MO, NC, NJ,  
 NV, NY, OH, PA, TN, TX, VA, WA  
 residents add applicable sales tax \$ \_\_\_\_\_

**Shipping/Handing Options**

**SEND ORDER FORM TO:**

Brother International Corp.  
 Attn: Consumer Accessory Div.  
 P.O. Box 341332  
 Bartlett, TN38184-1332

Please choose one:

- Standard (\$5.00)
- 2nd day air freight (\$8.75) Mandatory for all deliveries outside of the continental U.S. (Alaska, Hawaii, Puerto Rico, Virgin Islands & Canada)
- All other overseas orders (\$25.00) \$ \_\_\_\_\_

**TOTAL DUE (US dollars)** \$ \_\_\_\_\_

**Method of payment (Check one)**

Visa  MasterCard  Discover  American Express  Check/Money Order

Account Number \_\_\_\_\_  
 Expiration Date \_\_\_\_\_  
 Signature \_\_\_\_\_

\* Prices, taxes and shipping / handling charges subject to change without notice.





***GUÍA DE  
USUARIO***



# INTRODUCCIÓN

Gracias por adquirir el P-touch 1900/1910!

El nuevo P-touch le permitirá diseñar y crear etiquetas y membretes para cualquier tipo de aplicación. Su versatilidad le permitirá crear etiquetas personales seleccionando distintos diseños de marcos y muchos tamaños y estilos de caracteres. Además, los cinco diferentes anchos de cinta (1/4" (6 mm), 3/8" (9 mm), 1/2" (12 mm) y 3/4" (18 mm) y la variedad de los colores de la cintas le hará posible imprimir etiquetas personales.

Ya no hay por qué preocuparse por tareas urgentes que requieren impresión profesional. En la oficina, fábrica, laboratorio, o en casa, la calidad y el rendimiento del P-touch 1900/1910 la convierten en una máquina muy práctica.

Para terminar, puesto que esta guía del usuario le será de gran utilidad, le aconsejamos que la guarde en un lugar accesible para poder consultar en cualquier momento.

(Los modelos PT-1900 y PT-1910 disponen de las mismas funciones. Sin embargo, solamente el modelo PT-1910 incluye un estuche de transporte y cinta adicional.)

## AVISO DE LA FCC

**Este equipo ha sido probado y cumple con los límites de un aparato digital de la Clase B, siguiendo el apartado 15 de las normas de la FCC. Estos límites están pensados para proporcionar una protección razonable contra interferencias nocivas dentro de una instalación residencial. Este equipo podría interferir de forma nociva con comunicaciones por radio si no se instala y utiliza siguiendo las instrucciones. No obstante, no existe ninguna garantía de que no vayan a suceder interferencias en una instalación concreta. Si este equipo causara interferencias nocivas con la recepción de radio o televisión, lo cual puede determinarse poniendo el equipo en ON u OFF, se recomienda que el usuario intente corregir dichas interferencias mediante una de las siguientes medidas:**

- Reoriente o ponga la antena receptora en otro lugar.
- Aumente la separación entre el equipo y el receptor.
- Conecte el equipo en una toma de un circuito diferente de la que esté conectada el receptor.
- Consulte a su distribuidor o a un técnico experimentado de radio/televisión.
- Los cambios o modificaciones no aprobados expresamente por Brother Industries, Ltd. podrán invalidar la autorización que el usuario tiene para utilizar el equipo.

**A continuación se indican los números de patente y de publicación de patente relacionados con este producto:**

USP4839742	USP4983058	USP5120147
USP4927278	USP5009530	
USP4976558	USP5069557	

# ÍNDICE

CUIDADOS Y PRECAUCIONES GENERALES.....	1
PILAS.....	2
ADAPTADOR DE CA OPCIONAL.....	3
CASETES DE CINTA.....	4
COLOCACIÓN DE ETIQUETAS.....	5
CABEZA DE IMPRESIÓN Y RODILLOS.....	6
TECLA DEL CURSOR.....	7
TECLAS CODE, ALT Y SHIFT.....	8
TECLA DE RETORNO.....	9
TABULACIÓN.....	10
TECLA DE BORRADO (DEL).....	11
FUNCIÓN DE BORRADO DE LÍNEA (LINE OUT).....	12
FUNCIÓN DE REPOSICIÓN (CLEAR).....	12
FUNCIÓN DE ACENTOS.....	13
FUNCIÓN DE SÍMBOLOS.....	14
FUNCIÓN DE FORMATO AUTOMÁTICO.....	15
FUNCIÓN DE SELLOS.....	16
FUNCIÓN DEL TIPO DE CARACTERES.....	17
FUNCIONES DE TAMAÑO Y DE ANCHURA.....	17
FUNCIÓN DE ESTILO.....	19
FUNCIÓN DE SUBRAYADO.....	19
FUNCIÓN DE MARCOS.....	20
FUNCIÓN DE CINTA.....	21
FUNCIÓN DE LA ALINEACIÓN HORIZONTAL.....	21
FUNCIÓN DE IMPRESIÓN EN MODO ESPEJO.....	22
FUNCIÓN DE LONGITUD.....	23
FUNCIÓN DE CORTE AUTOMÁTICO.....	24
TECLA DE IMPRESIÓN.....	24
FUNCIÓN DE AVANCE Y CORTE.....	24
FUNCIÓN DE NUMERACIÓN.....	25
FUNCIÓN DE IMPRESIÓN REPETIDA.....	25
FUNCIONES DE LA MEMORIA.....	26
SOLUCIÓN DE PROBLEMAS.....	28
LISTA DE MENSAJES DE ERROR.....	29

ESPECIFICACIONES .....	32
ACCESORIOS.....	33
ÍNDICE ALFABÉTICO.....	36
INFORMACIÓN PARA CONTACTAR CON BROTHER.....	38



## **CUIDADOS Y PRECAUCIONES GENERALES**

- **Para evitar daños, no toque el borde de la cuchilla.**
- Con esta máquina emplee sólo cintas Brother TZ para evitar daños. No emplee cintas que no tengan la marca **TZ**. Brother no se hará responsable de problemas o daños ocasionados por el uso de suministros no autorizados.
- No tire de la cinta que se alimenta desde la P-touch. Podría dañar el casete de cinta.
- No utilice la máquina en lugares polvorientos, y manténgala alejada de la luz solar directa y la lluvia.
- No exponga la máquina a altas temperaturas ni humedad. No la deje nunca en el tablero de instrumentos ni en la parte trasera de su automóvil.
- No deje nada que sea de goma o vinyl encima de la máquina durante períodos prolongados. Podría producir manchas.
- No limpie la máquina con alcohol ni con otros solventes orgánicos. Emplee solamente un paño suave y seco.
- No ponga ningún objeto encima ni dentro de la máquina.
- Utilice sólo el adaptador de CA (modelo AD-60) exclusivamente diseñado para esta máquina. El empleo de otro cancelaría la garantía.
- No intente desmontar el adaptador de CA.
- Cuando el equipo no se utilice durante períodos prolongados de tiempo y no sea necesario conservar los archivos de texto en la memoria, desenchufe el adaptador de CA, y saque las pilas para evitar fugas de las mismas que podrían ser causa de daños en la máquina.
- Cuando el adaptador de CA esté enchufado en el equipo, si se desenchufa el adaptador de la toma de CA se correrá el riesgo de perder todos los archivos de texto de la memoria, aunque las pilas estén insertadas.
- **Este equipo utiliza, utilice seis pilas alcalinas o de manganeso de tamaño AA.**
- Si las pilas no están instaladas con sus polos positivo y negativo orientados en la dirección correcta, podrán producirse fugas en ellas, recalentarse o reventar, o el cabezal de impresión podrá recalentarse.

## PILAS

Esta máquina portátil puede utilizarse en cualquier lugar instalando seis (6) **pilas alcalinas AA**. Cuando cambie las pilas, reemplace siempre las seis pilas al mismo tiempo.

### Para cambiar las pilas:

- 1 Extraiga la cubierta del compartimiento de las pilas de la parte posterior de la máquina.
- 2 Si ya hay pilas instaladas, extráigalas.
- 3 Inserte seis pilas alcalinas AA nuevas, asegurándose de que sus polos queden orientados en la dirección correcta.
- 4 Coloque la cubierta del compartimiento de las pilas.

⚠ *Asegúrese de insertar las pilas nuevas antes de que transcurran cinco minutos desde que se extraen las pilas gastadas, porque de lo contrario el texto que se visualiza en la pantalla y los archivos de texto almacenados en la memoria se perderían (a menos que la máquina esté enchufada a una toma de CA con el adaptador de CA).*

*Si las pilas no están instaladas con sus polos positivo y negativo orientados en la dirección correcta, podrán producirse fugas en ellas, recalentarse o reventar, o el cabezal de impresión podrá recalentarse.*

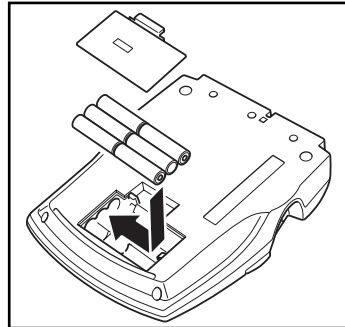
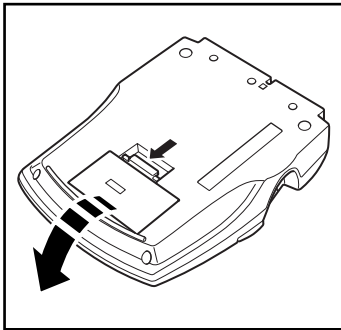

## ADAPTADOR DE CA OPCIONAL

El adaptador de CA (modelo AD-60) le permite emplear esta máquina siempre que disponga de una toma de corriente eléctrica.

### Para conectar el adaptador de CA opcional:

- 1 Inserte el conector del adaptador que tiene la marca DC IN 9,5V al lado derecho de la máquina.
- 2 Inserte la clavija del adaptador de CA en la toma de corriente más cercana.

☞ *Emplee sólo el adaptador de CA diseñado exclusivamente para esta máquina.*

*Extraiga las pilas y desconecte el adaptador de CA si no se propone utilizar el equipo durante períodos de tiempo prolongados. Cuando se desconecta la alimentación, se pierden el texto que se muestra en la pantalla y el que está almacenado en la memoria.*

*Cuando el adaptador de CA esté enchufado en la máquina, si se desenchufa el adaptador de la toma de CA se correrá el riesgo de perder todos los archivos de texto de la memoria, aunque las pilas estén insertadas.*

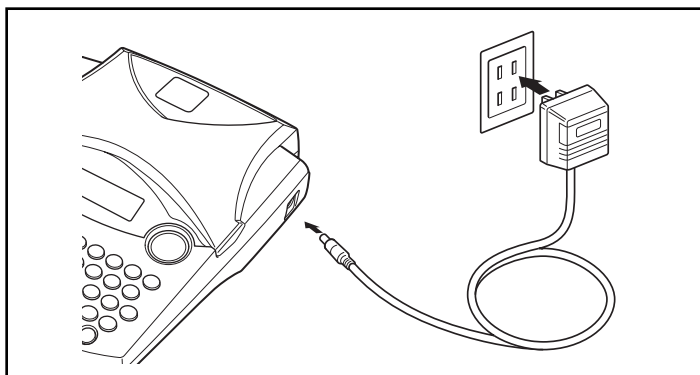

## CASETES DE CINTA

Un casete de TZ se suministra con la unidad. Sin embargo, para esta máquina hay disponibles una amplia gama de cintas TZ de distintos colores y tamaños, es posible crear etiquetas diferentes codificadas por colores o tamaños.

Además, este equipo ha sido diseñado para permitirle cambiar los casetes de cinta rápida y fácilmente.

### Para cambiar el casete de cinta:

- 1 Levante la cubierta del compartimiento de la cinta para abrirla. Se libera también entonces el casete instalado.
- 2 Si ya hay un casete instalado, extráigalo tirando del mismo recto hacia arriba.
- 3 Si la cinta entintada del casete que quiere instalar está floja, bobine la rueda dentada en el sentido de la flecha indicada en el casete utilizando su dedo hasta tensar la cinta. Además, cerciórese de que el extremo de la cinta esté debajo de las guías de la misma.  
*☞ Si está utilizando un casete de cinta nuevo provisto de retén, cerciórese de extraer éste.*
- 4 Inserte firmemente el casete de cinta en el compartimiento de la cinta asegurándose de que toda la parte posterior del casete está en contacto con la inferior del compartimiento.  
*☞ Cuando inserte el casete de cinta, asegúrese de que la cinta interior no esté enganchada en la esquina de la guía metálica.*
- 5 Cierre la cubierta del compartimiento y conecte la alimentación de la máquina si estaba desconectada.
- 6 Mantenga pulsada **Code** y presione **Feed&Cut** una vez para que la cinta avance y así quede con la tensión óptima.

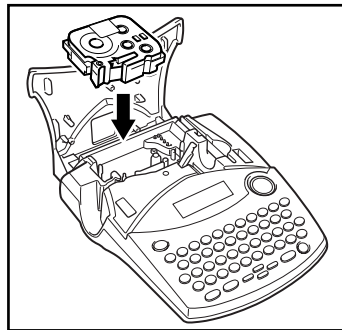
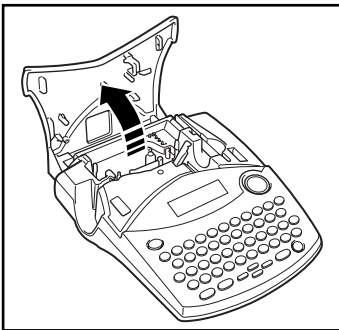

## COLOCACIÓN DE ETIQUETAS

### CINTA LAMINADA

La varilla suministrada permite que, en las cintas laminadas, usted pueda extraer fácilmente el papel del dorso de la etiqueta.

- 1 Tome la cinta con la mano izquierda, con la superficie impresa arriba, y tome la varilla con la mano derecha.
- 2 Pase la mitad de la cinta por el orificio estrecho largo de la varilla.
- 3 Gire tres cuartos de vuelta la varilla hacia usted y separe la varilla de usted como se muestra abajo.
- 4 Quite el papel del dorso de la etiqueta.

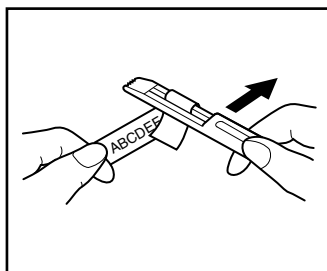
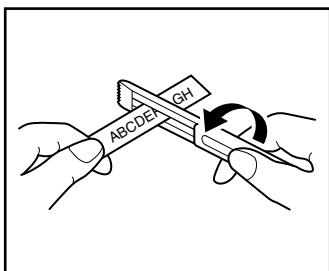
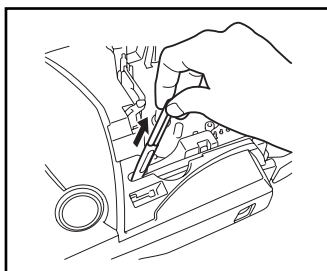

### CINTAS DE TELA

La cinta de tela se emplea para adherir un trozo de tela impresa con el texto en la prenda de vestir empleando una plancha. Después de imprimir el texto en la cinta de tela y de haber cortado la etiqueta empleando unas tijeras, coloque la etiqueta sobre una prenda planchada en la posición en la que desee ponerla de modo que el texto impreso pueda leerse correctamente. Cubra la etiqueta con otra tela y emplee un ajuste de la plancha de temperatura medio-alta (320 a 356°F (160 a 180 °C)) para presionar con firmeza durante 15 a 30 segundos. Para más detalles, consulte las instrucciones suministradas con el casete de cinta de tela.

### CINTAS DE SELLOS

Consulte las página 16 para encontrar la explicación detallada sobre el empleo de cintas de mimbres para hacer mimbres.

## CABEZA DE IMPRESIÓN Y RODILLOS

De vez en cuando, el polvo se adhiere al cabezal de impresión y a los rodillos del equipo. Suele suceder cuando se emplea la unidad en exteriores o en lugares con mucho polvo. Si alguna parte de la cabeza térmica de impresión está cubierta de polvo, es posible que aparezca una franja horizontal negra por el texto de la etiqueta.

Por lo tanto, al igual que con las grabadoras de cintas, la cabeza del equipo deberá limpiarse de vez en cuando.

### Para limpiar el cabezal de impresión y los rodillos:

- 1 Abra la cubierta del compartimiento de la cinta, extraiga el casete, si está dentro.
- 2 Abra la cubierta del compartimiento de la cinta, extraiga el casete, si está dentro. La cabeza de impresión y los rodillos están situados dentro del compartimiento de la cinta.
- 3 Cabezal de impresión: Emplee un palillo con punta de algodón seco para frotar con cuidado la cabeza de impresión con movimiento hacia arriba y abajo. Rodillos: Emplee un palillo con punta de algodón seco para frotar cada rodillo con movimiento hacia arriba y abajo mientras los gira con el dedo.
- 4 Instale un casete de cinta, cierre la cubierta del compartimiento de la cinta, y después pruebe de nuevo la impresión.
- 5 Si todavía aparece una franja negra en la etiqueta, repita los pasos 3 y 4 utilizando un palillo con punta de algodón mojado con alcohol isopropílico (de limpieza).

Si no funciona nada de lo de arriba, póngase en contacto con el representante de servicio.

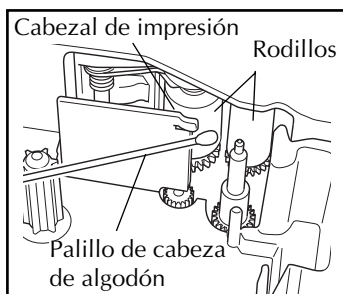
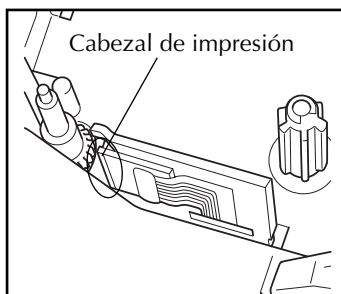
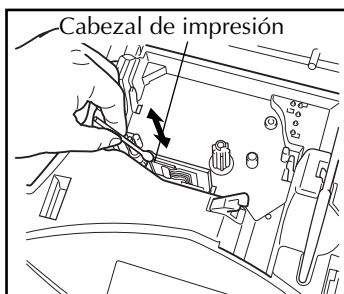



El cabezal de impresión se podrá limpiar más fácilmente empleando el casete de limpieza de cabezales de impresión opcional (TZ-CL4).

## TECLA DEL CURSOR

La pantalla de LCD de esta máquina muestra dos filas de 9 caracteres; sin embargo, el texto que usted diseñe puede tener hasta 99 caracteres de longitud. Podrá revisar y editar diferentes partes de la izquierda moviendo el cursor hacia atrás y hacia adelante.

### TECLA DEL CURSOR IZQUIERDA



**Para mover el cursor un carácter hacia la izquierda:**

- Presione  una vez.  
 Si se presiona esta tecla cuando el cursor esté al comienzo de una línea que sigue a otra línea, el cursor se moverá hasta el final de la línea anterior.

**Para mover el cursor varios caracteres hacia la izquierda:**



- Mantenga presionado  hasta que el cursor se mueva a la posición deseada.

**Para mover el cursor al principio de la línea actual:**

- Mantenga presionado  y presione .

### TECLA DEL CURSOR DERECHA



**Para mover el cursor un carácter hacia la derecha:**

- Presione  una vez.  
 Si se presiona esta tecla cuando el cursor esté al final de una línea a la que sigue otra línea, el cursor se moverá hasta el principio de la línea siguiente.

**Para mover el cursor varios caracteres hacia la derecha:**

- Mantenga presionado  hasta que el cursor se mueva a la posición deseada.

**Para mover el cursor al final de la línea actual:**

- Mantenga presionado  y presione .

### TECLA DEL CURSOR HACIA ARRIBA



**Para mover el cursor a la línea anterior:**

- Presione  una vez.  
 Si el cursor está en la primera línea del texto, se moverá al principio de la línea.

**Para mover el cursor varias líneas hacia arriba:**



- Mantenga presionado  hasta que el cursor se mueva a la línea deseada.

**Para mover el cursor al principio de todo el texto:**

- Mantenga presionado  y presione .

### TECLA DEL CURSOR HACIA ABAJO



**Para mover el cursor a la línea siguiente:**

- Presione  una vez.  
 Si el cursor está en la última línea del texto, se moverá al final de la línea.

### Para mover el cursor varias líneas hacia abajo:

- Mantenga presionado  hasta que el cursor se mueva a la línea deseada.

### Para mover el cursor al final de todo el texto:

- Mantenga presionado  y presione .

## TECLAS CODE, ALT Y SHIFT

La mayoría de los caracteres pueden introducirse simplemente presionando sus teclas. Sin embargo, para emplear funciones especiales o para introducir letras en mayúsculas, caracteres acentuados y algunos símbolos, se requieren las siguientes teclas especiales.



### TECLA CODE

#### Para emplear una función impresa encima de la tecla:

- Mantenga presionado  y presione la tecla que está inmediatamente debajo de la función deseada.

### TECLA ALT

#### Para escribir los caracteres impresos en color del lado derecho de las teclas:

- Mantenga presionado  y presione la tecla del carácter deseado escrita en color. El indicador **Alt**, de la izquierda del visualizador, se encenderá mientras se tiene presionado .





### TECLA SHIFT

#### Para escribir una letra mayúscula o un símbolo impreso en la esquina superior izquierda de la tecla:

- Mantenga presionado  y presione la tecla de la letra o símbolo deseado.

El modo de **Mayúsculas** funciona de forma similar que manteniendo pulsada . Le permite teclear letras mayúsculas continuamente.

#### Para escribir muchas letras mayúsculas:

- 1 Mantenga presionado  y presione . El indicador de **Caps**, de la izquierda del visualizador, se encenderá.
- 2 Presione las teclas de las letras o símbolos dedicados.
- 3 Para salir del modo **Caps**, mantenga presionado  y presione . Se apagará el indicador de **Caps**.



## TECLA DE RETORNO

Al igual que en una máquina de escribir o procesador de texto, la tecla de **Retorno** (  ) de esta máquina se emplea para poner fin a una línea de texto y empezar otra. Cuando haya terminado de introducir una línea, presione la tecla de retorno para hacer una línea nueva y mover al cursor a la misma.

☞ El texto solamente puede contener un máximo de cuatro líneas. Si presiona  cuando ya existan cuatro líneas, aparecerá el mensaje de error "4 LINE LIMIT!".

Anchuras de cinta	Número máximo de líneas que pueden imprimirse
1/4" (6 mm)	2
3/8" (9 mm)	2
1/2" (12 mm)	3
3/4" (18 mm)	4
Sello 3/4" (18 mm)	3

La tecla de retorno también podrá utilizarse para seleccionar un objeto de una lista (p. ej., añadir un símbolo o un carácter acentuado al texto) o para aplicar un ajuste seleccionado.

Es posible que aparezcan en el visualizador de LCD algunas preguntas para que confirme un comando, especialmente cuando la función que usted ha seleccionado es para borrar o afectar archivos. En estos casos, si presiona  es como si respondiera "sí".

☞ Para contestar "no", presione . Consulte la descripción de la **TECLA DE BORRADO (DEL)** de la página 11.

# TABULACIÓN

Esta función le permitirá separar secciones de una línea de texto añadiendo **tabulaciones**. Esto le permitirá crear columnas perfectamente alineadas sin tener que introducir varios espacios. Todas las tabulaciones tendrán la misma longitud y se medirán desde el comienzo de la línea, o de la tabulación anterior, si es que existe. La longitud de las tabulaciones podrá ajustarse entre 0,0" y 11,8" (0,0 y 30,0 cm).

El texto no podrá contener más de 50 tabulaciones. Si ya se ha añadido el número máximo de tabulaciones al texto, cuando se mantenga presionada **Code** y se presione **Q**, aparecerá el mensaje de error "TAB LIMIT!"

Part No.	Product	Price
8667	Printer	\$300
122960	Fax	\$100

## Para ajustar la longitud de las tabulaciones:

- Mantenga pulsada **Code** y presione **W** una vez. Se visualizará la longitud de tabulación actual.
- Presione **Home** o **End** hasta que se visualice la longitud deseada, o utilice las teclas numéricas para introducir la longitud.

Para cambiar las unidades (pulgadas o centímetros) utilizadas para la indicación de la longitud de las tabulaciones, presione **M<sub>n</sub>** hasta que se visualicen las unidades deseadas.
- Presione **↵**.

## Para añadir una tabulación:

- Mantenga pulsada **Code** y presione una vez **Q**. La marca de tabulación (**T**) aparecerá en el texto para indicar la posición de la tabulación.

Si el texto delante de una tabulación sobrepasa el punto en el que tiene que comenzar la sección siguiente de texto, tal texto comenzará en la siguiente posición de tabulación.



Por ejemplo, si la longitud está ajustada a 1,2" (3,0 cm) y escribe el texto siguiente:

1: A B C **T** D E F **T** G H I ↵  
2: J K L M N O P Q R S **T** U

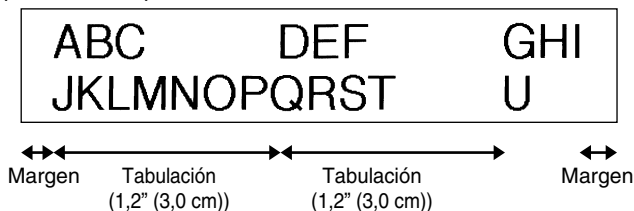
Se imprimirá la etiqueta mostrada a continuación.



## TECLA DE BORRADO (DEL)





La tecla de **Borrado** (  ) le permite eliminar caracteres situados a la izquierda de la posición actual del cursor. Se diferencia de la tecla del cursor izquierda (  ) que sólo mueve el cursor sin borrar ningún carácter.

La tecla de borrado también puede utilizarse para abandonar la mayor parte de funciones y volver a la visualización anterior sin cambiar el texto.





Es posible que aparezcan en el visualizador de LCD algunas preguntas para que confirme un comando, especialmente cuando la función que usted ha seleccionado es para borrar o afectar archivos. En estos casos, si presiona  es como si respondiera "sí".

☞ Para contestar "no", presione . Consulte la descripción de la **TECLA DE RETORNO** de la página 9.

### Para borrar un carácter:

- 1 Presione , ,  o  para situar el cursor debajo del carácter que está inmediatamente a la derecha del carácter que usted desea borrar.
- 2 Presione  una vez.









### Para borrar una secuencia de caracteres:

- 1 Presione , ,  o  para situar el cursor debajo del carácter que está inmediatamente a la derecha del último carácter que usted desea borrar.
- 2 Mantenga presionado  hasta que se hayan borrado todos los caracteres que usted deseaba borrar.

## FUNCIÓN DE BORRADO DE LÍNEA (LINE OUT)

Con la función de **borrado de línea**, podrá sacar con facilidad una línea entera de texto.







**Para borrar una línea de texto:**

- 1 Presione , ,  o  para situar el cursor dentro de la línea del texto que usted desee borrar.
- 2 Mantenga presionado  y presione  una vez.  
 Cada vez que se presione  mientras se tiene presionado , ise borrará una línea de texto.

## FUNCIÓN DE REPOSICIÓN (CLEAR)

Si borra la visualización antes de introducir nuevo texto, la función **reposición** podrá utilizarse para elegir si se desea borrar todo el texto, y todas las funciones de formato (**tipo de caracteres, tamaño, ancho, estilo, subrayado, marco, margen de la cinta, alineación, longitud de la tabulación, impresión en modo espejo y longitud**) volverán a sus ajustes iniciales, o borrar solamente texto.

**Para borrar todo el texto y reponer todos los formatos a sus ajustes iniciales:**

- 1 Mantenga presionado  y presione .
- 2 Presione  o  hasta que se seleccione **TXT&FORMAT** (parpadeando).  
 Para volver al texto sin borrar nada, presione .
- 3 Presione .















## FUNCIÓN DE ACENTOS

La función de **Accentos** también se puede utilizar para añadir caracteres acentuados a su texto. Muchos de estos caracteres también se pueden escribir utilizando la función de **Símbolos**.

Los caracteres acentuados se agrupan de acuerdo con la letra mayúscula o minúscula con la que se combinan. Hay disponibles los siguientes caracteres acentuados:

Letras	Caracteres acentuados	Letras	Caracteres acentuados
a	à á â ã ä å æ	l	í î ï
A	À Á Â Ã Ä Å Æ	n	ñ
c	ç	N	Ñ
C	Ç	o	ó ô õ ö
e	è é ê ë	O	Ó Ö Ô Õ
E	È É Ê Ë	u	ù ú û ü
i	í î ï	U	Ù Ú Û Ü

### Para escribir un carácter acentuado:

- 1 Mantenga presionado  y presione . Aparecerá el mensaje "ACCENT a - u / A - U?" en el visualizador.
- 2 Presione la tecla de la letra acentuada deseada.
  -  Para escribir una letra mayúscula, mantenga pulsada  (o mantenga pulsada  y presione  para pasar al modo de **mayúsculas**) antes de pulsar la tecla de la letra.
- 3 Presione  o  hasta que aparezca el carácter acentuado deseado ampliado dentro del recuadro en el centro del visualizador.
- 4 Presione . El carácter acentuado será añadido al texto.
  -  Para escribir una secuencia de caracteres acentuados, mantenga presionada  antes de pulsar . Después continúe añadiendo caracteres acentuados seleccionándolos como se ha explicado en los pasos 2 y 3, manteniendo pulsada  y presionando . Después de haber seleccionado el último carácter de la serie, presione simplemente .

## FUNCIÓN DE SÍMBOLOS

Además de letras, de los símbolos y los números de las teclas, hay 53 marcas adicionales con la función de **símbolos**.

Los siguientes símbolos están disponibles:

Grupo	Símbolos
1	Ü Æ æ Ã ã Ę ě Ő ő • ° ™
2	+ × ÷ = § ² ³ ² ³ 4 [ ]
3	↑ ↓ → ← ↩ ↪ Ⓞ Ⓒ ☎ 📁 📧 ☠
4	🌐 🍷 🔥 ♿ ⚡ 🎬 🌐 🌐 🔑 🌐 🍀 🌿
5	👤 🍷 🎵 ♥ ★

### Para escribir un símbolo:

- 1 Mantenga presionado **Code** y presione **Alt**<sup>Symbol</sup>. Aparecerá una fila de símbolos en el visualizador.
- 2 Presione **Home** o **End** para visualizar diferentes filas de símbolos y presione **<<** o **>>** hasta que aparezca el símbolo deseado ampliado en el recuadro en el centro del visualizador.
- 3 Presione **↵**. El símbolo será añadido al texto.
  - ☛ *Para escribir una secuencia de símbolos, mantenga presionada **Code** antes de pulsar **↵**. Después continúe añadiendo símbolos seleccionándolos como se ha explicado en los pasos 2 y 3, manteniendo pulsada **Code** y presionando **↵**. Después de haber seleccionado el último símbolo de la serie, presione simplemente **↵**.*





## FUNCIÓN DE FORMATO AUTOMÁTICO



Con la función de **formato automático**, podrá seleccionar gran variedad de formatos preajustados adecuados para su necesidad específica. Esta función ajustará automáticamente la longitud de la etiqueta y los márgenes de la cinta sin cambiar el texto ni ningún otro formato, permitiéndole crear etiquetas con mayor rapidez y facilidad.

Los formatos preajustados son los siguientes:

Ajuste de formato automático	Ajuste de longitud de la etiqueta	Aajuste del margen de la cinta	Aajuste de la alineación horizontal
DEFAULT	OFF	FULL	LEFT
3,5"FLOPPY	2,8" (7,0 cm)	NARROW	CENTER
miniDV	1,7" (4,3 cm)	NARROW	CENTER
VHS SPINE	5,5" (14,0 cm)	NARROW	CENTER
VHS	3,0" (7,7 cm)	NARROW	CENTER
VCR8mm CASE	3,6" (9,2 cm)	NARROW	CENTER
VCR8mm	2,9" (7,3 cm)	NARROW	CENTER
VHS-C SPINE	1,8" (4,5 cm)	NARROW	CENTER
VHS-C	2,3" (5,8 cm)	NARROW	CENTER
AUDIO CASSETTE	3,5" (8,9 cm)	NARROW	CENTER
DAT CASSETTE	2,2" (5,6 cm)	NARROW	CENTER
MINI DISK	2,0" (5,2 cm)	NARROW	CENTER
ORGANISER L	3,2" (8,2 cm)	NARROW	CENTER
ORGANISER S	2,6" (6,5 cm)	NARROW	CENTER
FILE LONG	7,2" (18,3 cm)	NARROW	CENTER
FILE SHORT	3,7" (9,4 cm)	NARROW	CENTER

### Para seleccionar un formato preajustado:

- ❶ Mantenga pulsada  y presione una vez . El ajuste actualmente seleccionado parecerá en el visualizador.
- ❷ Pulse  o  para seleccionar el ajuste deseado.
 





 El ajuste predeterminado (**DEFAULT**) podrá seleccionarse presionando .
- ❸ Presione  para aplicar el ajuste seleccionado.
 

 El indicador de **longitud** se encenderá cuando seleccione un ajuste que no sea **DEFAULT**.

## FUNCIÓN DE SELLOS

Le permite crear con rapidez y facilidad sus propios sellos. Después de haber insertado un casete de clichés, seleccione esta función para centrar automáticamente el texto y ajustar la longitud de la cinta y los márgenes a un formato perfecto para los soportes de películas de membrete entintados. Puesto que el soporte del membrete es reutilizable, haga un nuevo cliché de membrete y reemplácelo por el que hay en el soporte de películas.

### Para hacer un membrete:

- 1 Escriba el texto, y después inserte un casete de película de membretes de tamaño medio (3/4" (18 mm) de anchura).
- 2 Mantenga presionado  y presione  una vez. Aparecerá el mensaje "STAMP FORMAT?" en el visualizador.
- 3 Presione . El texto se formateará automáticamente para el membrete instalado: centrado dentro del área preajustada del mensaje, con la longitud y los márgenes de la cinta automáticamente ajustados.
- 4 Presione  para separar el texto del cliché de membrete.
- 5 Después de haber cortado la película matriz de sellos, extraiga el papel del dorso del cliché del membrete y adhiéralo al tampón de tinta o soporte de películas.

### Para adherir un membrete:

- 1 Extraiga el marco del membrete de entorno al lado al tampón de tinta del soporte de películas de una vez, y saque entonces el sello protector que cubre el tampón de tinta y el papel del dorso del cliché del membrete.
- 2 Con el lado brillante del cliché del membrete encarado hacia arriba, alinee uno de sus extremos con la ranura del lado del soporte de películas de membrete.
- 3 Retenga el extremo del cliché del membrete en su lugar con el dedo pulgar, y pase la cinta por las guías mientras la tensa bien.
- 4 Pliegue el otro extremo del cliché del membrete por en otro lado del soporte de películas de membrete y reténgalo en su lugar con el dedo.
- 5 Adapte el marco del membrete encima del cliché del membrete y presiónelo a su lugar.
- 6 Inserte el soporte de películas de membrete recto en su tapa.

 Asegúrese de que el membrete quede correctamente cubierto para evitar derrames de tinta.



## FUNCIÓN DEL TIPO DE CARACTERES

Con la función del **tipo de caracteres** podrá seleccionar uno de cuatro de tipos de caracteres para su texto.



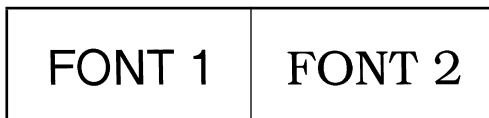



Los ajustes de tipos de caracteres siguientes están disponibles:



El ajuste inicial del tipo de caracteres es **FONT 1**. El indicador de tipo de caracteres de la parte inferior izquierda del visualizador muestra el tipo de caracteres seleccionado actualmente.

Consulte el apartado de *Referencia*, al final de esta sección, para ver muestras de los ajustes disponibles.

**Para cambiar el ajuste del tipo de caracteres:**

- 1 Manteniendo presionada , pulse una vez , y mantenga presionada  para hacer que se visualice el tipo de caracteres actualmente ajustado.
- 2 Siguiendo manteniendo presionada , continúe presionando  hasta que se visualice el tipo de caracteres actualmente ajustado.  
 *El ajuste de tipo actual se mostrará en el indicador de estilo de la esquina inferior derecha del visualizador.*
- 3 Para aplicar el ajuste de tipo de caracteres seleccionado a todo el texto, suelte .

## FUNCIONES DE TAMAÑO Y DE ANCHURA

El tamaño de los caracteres puede ajustarse empleando las funciones de **tamaño** (Size) y de **ancho** (Wide). Puesto que el tamaño de los caracteres que puede utilizarse depende del ancho de la cinta, la tabla siguiente indica los tamaños de caracteres que pueden utilizarse con cada ancho de cinta.





Anchos de cinta	Tamaños (en puntos)
1/4" (6 mm)	6, 9, 12
3/8" (9 mm)	6, 9, 12, 18
1/2" (12 mm)	6, 9, 12, 18, 24
3/4" (18 mm)	6, 9, 12, 18, 24, 36, 42

El ajuste de tamaño inicial es **AUTO** y el ajuste de ancho inicial es **OFF**. El ajuste de tamaño seleccionado actualmente se indica siempre mediante los indicadores de encima del visualizador.

Con el ajuste de tamaño **AUTO**, la máquina compara el texto ajustado con el ancho de la cinta instalada y ajusta automáticamente los caracteres al tamaño más grande posible. Sin embargo, también hay disponibles otros siete tamaños, y cada uno puede imprimirse con cualquiera de los dos ajustes de anchura.

 Con el ajuste **AUTO** seleccionado y una cinta de 1/2" (12 mm) o, 3/4" (18 mm) de ancho instalada, el texto que consista en una sola línea de letras mayúsculas solamente (y sin caracteres acentuados) será impreso con un tamaño de carácter ligeramente más grande que el máximo posible (29 puntos para cinta de 1/2" (12 mm) de ancho, y 52 puntos para cinta de 3/4" (18 mm) de ancho).







### Para cambiar el ajuste del tamaño:

- 1 Manteniendo presionada , pulse una vez , y mantenga presionada  para hacer que se visualice el tamaño actualmente ajustado.
- 2 Siguiendo manteniendo presionada , continúe presionando  hasta que se visualice el tamaño actualmente ajustado mediante el indicador del mismo.

 El ajuste de tamaño actual se muestra mediante los indicadores de tamaño en la parte superior del visualizador.

- 3 Para aplicar el ajuste de tamaño seleccionado a todo el texto, suelte .

### Para cambiar el ajuste de anchura:

- 1 Manteniendo presionada , pulse una vez , y mantenga presionada  para hacer que se visualice el ancho actualmente ajustado.
- 2 Siguiendo manteniendo presionada , continúe presionando  hasta que se visualice el ancho actualmente ajustado.
- 3 Para aplicar el ajuste de ancho seleccionado a todo el texto, suelte .

## FUNCIÓN DE ESTILO

Podrá seleccionar entre nueve estilos de caracteres distintos que podrá aplicar a su texto.

☞ *Los caracteres que se imprimen utilizando los tamaños más pequeños pueden resultar difíciles de leer si se seleccionan ciertos ajustes de estilos (por ejemplo, **I+SHAD**).*







Hay disponibles los siguientes ajustes de estilos:

**NORMAL**, **BOLD** (negrilla), **OUTLINE** (perfilado), **SHADOW** (sombreado),  
**ITALIC** (cursiva), **I+BOLD** (cursiva y negrilla), **I+OUTL** (cursiva y perfilado),  
**I+SHAD** (cursiva y sombreado), **VERT** (vertical),

El ajuste de estilo inicial es **NORMAL**. El indicador de estilo de la parte inferior del visualizador muestra el ajuste de estilo actual cuando se selecciona cualquier ajuste diferente a **NORMAL**.

Consulte el apartado de *Referencia*, al final de esta sección, para ver muestras de los ajustes disponibles.

**Para cambiar el ajuste del estilo:**

- 1 Manteniendo presionada , pulse una vez , y mantenga presionada  para hacer que se visualice el estilo actualmente ajustado.
- 2 Siguiendo manteniendo presionada , continúe presionando  hasta que se visualice el estilo actualmente ajustado mediante el indicador del mismo.  
☞ *El ajuste de estilo actual se mostrará en el indicador de estilo de la esquina inferior derecha del visualizador.*
- 3 Para aplicar el ajuste de estilo seleccionado a todo el texto, suelte .

## FUNCIÓN DE SUBRAYADO

Podrá acentuar el texto subrayándolo.

El ajuste de subrayado predeterminado es **OFF**. Cuando la función de **Subrayado** sea ajustada en **ON**, se encenderá el indicador de subrayado **Underline** en la parte inferior derecha del visualizador.

UNDL  
ON

ABC

(Ejemplo)

### Para cambiar el ajuste del subrayado:

- 1 Manteniendo presionada **(Code)**, pulse una vez **( $\frac{\%}{5}$ )**, y mantenga presionada **(Code)** para hacer que se visualice el subrayado actualmente ajustado.
- 2 Siguiendo manteniendo presionada **(Code)**, continúe presionando **( $\frac{\%}{5}$ )** hasta que se visualice el subrayado actualmente ajustado mediante el indicador del mismo.  
 Cuando seleccione el ajuste **ON**, el indicador de **Underline** se encenderá.
- 3 Para aplicar el ajuste de subrayado seleccionado a todo el texto, suelte **(Code)**.

## FUNCIÓN DE MARCOS

Con la función de **marcos**, podrá seleccionar diversos marcos y funciones destacadas para hacer un diseño más decorativo o una etiqueta con más énfasis

El ajuste inicial es **OFF**; sin embargo, también hay disponibles los siguientes seis ajustes.

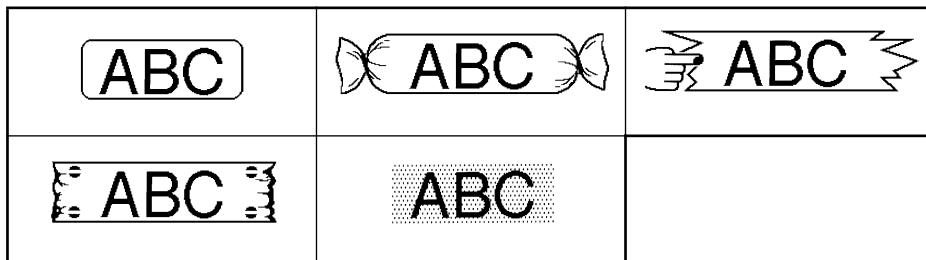

Si se selecciona cualquier ajuste que no sea **OFF**, se encenderá el indicador de **Frame**, situado a la derecha del visualizador.

### Para cambiar el ajuste del marco:

- 1 Manteniendo presionada **(Code)**, pulse una vez **( $\frac{\text{C}}{6}$ )**, y mantenga presionada **(Code)** para hacer que se visualice el marco actualmente ajustado.
- 2 Siguiendo manteniendo presionada **(Code)**, continúe presionando **( $\frac{\text{C}}{6}$ )** hasta que se visualice el marco actualmente ajustado mediante el indicador del mismo.  
 El indicador de **Frame** se enciende si se selecciona un ajuste que no sea **OFF**.
- 3 Para aplicar el ajuste de marco seleccionado a todo el texto, suelte **(Code)**.

## FUNCIÓN DE CINTA

La función de **margen cinta** le permite ajustar el tamaño de los márgenes de los lados izquierdo y derecho del texto.







El ajuste inicial de margen cinta es **FULL**, aunque hay también disponibles otros tres ajustes.

**FULL** (márgenes de 1" (24 mm))      **NARROW** (márgenes de 1/6" (4 mm))

**NONE** (márgenes de 5/64" (2 mm))      **HALF** (márgenes de 1/2" (12 mm))

 Cuando seleccione otro ajuste diferente a **FULL**, avanzará cinta extra antes de iniciarse la impresión.

**Para cambiar el ajuste de la cinta:**

- 1 Manteniendo presionada , pulse una vez , y mantenga presionada  para hacer que se visualice la cinta actualmente ajustado.
- 2 Siguiendo manteniendo presionada , continúe presionando  hasta que se visualice la cinta actualmente ajustado.
- 3 Para aplicar el ajuste de la cinta seleccionado a todo el texto, suelte .

## FUNCIÓN DE LA ALINEACIÓN HORIZONTAL

Podrá elegir alinear texto en una de las tres formas disponibles. Además, si utilizó la función de **longitud** para ajustar la longitud de la etiqueta, los texto se alinearán dentro de la etiqueta de acuerdo con el ajuste de alineación horizontal seleccionado.

El ajuste inicial es **LEFT**; sin embargo, también hay disponibles otros dos ajustes.

**LEFT**

AB  
CDE  
FG

**RIGHT**

AB  
CDE  
FG

**CENTER**

AB  
CDE  
FG

### Para cambiar el ajuste de la alineación horizontal:

- 1 Manteniendo presionada **Code**, pulse una vez **Align R**, y mantenga presionada **Code** para hacer que se visualice la alineación horizontal actualmente ajustado.
- 2 Siguiendo manteniendo presionada **Code**, continúe presionando **Align R** hasta que se visualice la alineación horizontal actualmente ajustado.
- 3 Para aplicar el ajuste de la alineación seleccionado a todo el texto, suelte **Code**.

## FUNCIÓN DE IMPRESIÓN EN MODO ESPEJO

Esta función imprime su etiqueta de modo que el texto de la misma puede leerse desde el lado adhesivo de la cinta. Si se adhieren etiquetas con impresión en modo espejo a un vidrio, o en otro material transparente, podrán leerse correctamente desde el lado opuesto.

☞ Cuando emplee la función de **impresión en modo espejo**, el texto se imprimirá en cinta transparente.

El ajuste inicial para la impresión en mode espejo es **OFF**.

ON



### Para activar o desactivar la impresión en modo espejo:













- 1 Manteniendo presionada **Code**, pulse una vez **Mirror Print**, y mantenga presionada **Code** para hacer que se visualice la impresión en modo espejo actualmente ajustado.
- 2 Siguiendo manteniendo presionada **Code**, continúe presionando **Mirror Print** hasta que se visualice la impresión en modo espejo actualmente ajustado.
- 3 Para aplicar el ajuste de la impresión en modo espejo seleccionado a todo el texto, suelte **Code**.

## FUNCIÓN DE LONGITUD

Aunque la longitud de la etiqueta impresa ajusta automáticamente dicha longitud de acuerdo con el texto introducido, es posible que usted desee hacer una etiqueta con una longitud específica. La función de **longitud** le permitirá ajustar la longitud de la etiqueta entre 1,6" y 11,8" (4,0 cm y 30,0 cm).

El ajuste predeterminado de longitud es **OFF**. Cuando ponga la función de **longitud** en **ON**, se encenderá el indicador de **longitud** de la parte derecha del visualizador.

### Para activar y desactivar la función de longitud:

- 1 Manteniendo presionada , presione una vez , y mantenga presionada  hasta que se visualice brevemente la longitud actual de la etiqueta (texto y ambos márgenes). Después el visualizador mostrará el ajuste de longitud de etiqueta actual (**ON** u **OFF**).
- 2 Manteniendo presionada , continúe presionando  hasta que se visualice el ajuste de longitud de etiqueta deseado.  
*☞ Cuando seleccione **ON**, se encenderá el indicador de **longitud**.*
- 3 Suelte . Si había seleccionado **ON**, se visualizará la longitud actual de la etiqueta.
- 4 Presione  o  para seleccionar la longitud deseada, o utilice las teclas numéricas para introducir la longitud.  
*☞ Para cambiar las unidades (pulgadas o centímetros), presione  hasta que aparezcan las unidades deseadas.*  
*Para cambiar la longitud en pasos de 1" (1,0 cm), mantenga pulsada  o , y después presione la tecla cuando se visualice el ajuste deseado.*
- 5 Presione .

## FUNCIÓN DE CORTE AUTOMÁTICO

La función de **Corte automático** le permite ajustar si la máquina va a cortar automáticamente o no cada etiqueta después de imprimirla. Active la función de **corte automático** antes de empezar a imprimir para cortar automáticamente las etiquetas después de imprimirlas.

☞ Después de imprimir una etiqueta con la función de **Corte automático** ajustada en **OFF**, mantenga presionada **Code** y presione **Feed&Cut Space** una vez para avanzar la cinta, y después córtela.

**Para activar o desactivar la función de corte automático:**

- 1 Mientras mantiene presionada **Code**, presione una vez **A.Cut Z** y mantenga presionada **Code** para visualizar al ajuste de corte automático actual.
- 2 Mientras mantiene presionada **Code**, continúe presionando **A.Cut Z** hasta que se visualice el ajuste de corte automático deseado.
- 3 Suelte **Code** para aplicar el ajuste de corte automático seleccionado.

## TECLA DE IMPRESIÓN

Después de haber introducido su texto y de haber elegidos los ajustes de formato deseados, podrá imprimir.

☞ Si la función de **corte automático** está activada (**ON**), la etiqueta se cortará automáticamente después de haberse impreso.

**Para imprimir una etiqueta:**

- Presione **Mirror Print** una vez. Se visualizarán "COPIES" y el número de la etiqueta que esté imprimiéndose.  
☞ Si el tamaño de caracteres seleccionado es demasiado grande para el ancho del casete de cinta instalado, aparecerá el mensaje "CHR SIZE AUTO?". Para permitir que el tamaño de texto se ajuste automáticamente, presione **Mirror Print** o **↶**. Para impedir que el tamaño de texto sea cambiado, presione **Clear BS**.

## FUNCIÓN DE AVANCE Y CORTE

La función de **avance y corte** se utiliza para hacer que la cinta avance 1" (24 mm) y se corte automáticamente, por ejemplo después de haber impreso con la función de **corte automático** desactivada (**OFF**) o cuando se haya interrumpido la impresión.

**Para hacer que la cinta avance 1" (24 mm):**













- Mantenga pulsada **Code** y presione **Feed&Cut Space** una vez. La cinta avanzará 1" (24 mm) y se cortará.



## FUNCIÓN DE NUMERACIÓN

Esta función podrá utilizarse para imprimir muchas copias del mismo texto aumentando en cierto número en el texto después de haber impreso cada etiqueta.









**Para utilizar la función de numeración:**

- 1 Presione , , , o  para colocar el cursor debajo del número que desee aumentar.
- 2 Mantenga presionada  y presione . En el visualizador aparecerá el mensaje "NUMBER UNTIL" con el ajuste actual.
  - ☞ Para cancelar la función de **Numeración** en cualquier momento, mantenga presionada  y presione  (o simplemente presione ).
- 3 Utilice estas teclas numéricas para escribir el último número a imprimir.
  - ☞ El último número a imprimir también puede seleccionarse presionando  o . No podrá introducirse un número inferior al que haya sido seleccionado.
- 4 Para comenzar la impresión de etiquetas, presione  (o ). El número de cada copia se visualizará mientras esté copiándose.
  - ☞ Si la función **Margen de cinta** está puesta en cualquier otro ajuste diferente a **NONE**, se imprimirá una guía de corte (:) entre cada etiqueta para poder cortar la cinta al tamaño correcto.



## FUNCIÓN DE IMPRESIÓN REPETIDA

Esta función le permite imprimir hasta 9 copias del mismo texto.

**Para emplear la función de impresión repetida:**

- 1 Mantenga presionada  y presione . En el visualizador aparecerá el mensaje "COPIES" con el ajuste por defecto **1**, que habrá que cambiar según sea necesario.
  - ☞ Para cancelar la función de **impresión repetida** en cualquier momento, mantenga presionada  y presione  (o simplemente presione ).
- 2 Presione  o  hasta que se muestre el número deseado de copias, o utilice las teclas numéricas para escribir el número.
- 3 Presione  (o ) para empezar a imprimir las etiquetas. Se visualizará el número de cada copia mientras se imprime.
  - ☞ Si la función **Margen de cinta** está puesta en cualquier otro ajuste diferente a **NONE**, se imprimirá una guía de corte (:) entre cada etiqueta para poder cortar la cinta al tamaño correcto.

## FUNCIONES DE LA MEMORIA

Usted podrá utilizar la memoria para almacenar los archivos de texto que utilice con más frecuencia. El texto permanecerá en la memoria, junto con su formato, incluso después de haber quitado todos los caracteres del visualizador utilizando la función de **Borrado** (manteniendo presionada  y presionando .

Cuando se almacena un archivo, se le asigna un número para poder invocarlo fácilmente. En la memoria se pueden almacenar hasta 10 archivos de texto o aproximadamente 300 caracteres. (Un solo archivo de texto podrá contener un máximo de 91 caracteres.)



Cuando se desee un archivo de texto con la función de **memoria**, se aparecera archivo almacenado, el texto podrá editar o imprimirse sin cambiar el archivo originalmente almacenado. Cuando ya no necesite un archivo podrá utilizar la función de **borrado de la memoria**.



☞ *Cuando tenga que insertar nuevas pilas, hágalo antes de cinco minutos de haber extraído las viejas, ya que de lo contrario los archivos de texto almacenados en la memoria se perderían (a menos que la máquina esté enchufada en un tomacorriente de la red con el adaptador de alimentación de CA).*

### ALMACENAMIENTO DE TEXTO

**Para almacenar un archivo de texto:**

1 Mantenga presionada  y presione . En el visualizador aparecerá el mensaje "STORE" con el número de archivo seleccionado actualmente.

☞ *Para abandonar la función de **almacenamiento del texto**, mantenga pulsada  y presione  (o simplemente presione .*

2 Presione una tecla numérica (o presione  o ) para seleccionar el número de archivo donde quiera almacenar el texto.

3 Presione . El texto se almacenará en el número de archivo seleccionado y volverá a aparecer en el visualizador el texto previamente mostrado.

☞ *Si ya hay un archivo almacenado con el número de archivo seleccionado, en el visualizador aparecerá el mensaje "OVERWRITE?", y usted tendrá que decidir entre reescribir o borrar tal archivo.*

☞ *Si ya se ha almacenado el número máximo de caracteres, aparecerá el mensaje "MEMORY FULL!" en el visualizador. Cuando ocurra esto, tendrá que borrar un mensaje existente antes de poder almacenar otro nuevo.*















**Par reescribir un archivo almacenado con otro nuevo:**

● Presione  para borrar el archivo previamente almacenado y almacenar el nuevo con el número seleccionado.

☞ *Para retroceder y elegir otro número de archivo sin perder el archivo de texto, presione , y después seleccione un número de archivo diferente.*

















## INVOCACIÓN DE TEXTO

### Para invocar un archivo de texto:



- 1 Mantenga presionada  y presione . En el visualizador aparecerá el mensaje "RECALL" con el número de archivo y el principio del texto almacenado o invocado más recientemente.  
 Para abandonar la función de **memoria** sin solicitar texto, mantenga pulsada  y presione  (o presione simplemente ).
- 2 Presione una tecla numérica (o presione  o ) para seleccionar el número de archivo que contenga el texto que quiera invocar. Se mostrará el texto almacenado en el número de archivo seleccionado.  
 Para ver otras partes del archivo de texto seleccionado, presione  o .  
 Para hacer que se visualice el texto almacenado en otros números de archivos, presione  o , o la tecla correspondiente a otro número de archivo.
- 3 Presione . Cualquier texto previamente introducido se borrará y el texto introducido en el número de archivo seleccionado se verá en la pantalla.

## BORRADO DE UN ARCHIVO







### Para borrar un archivo de texto:





- 1 Mantenga presionada  y presione . En el visualizador aparecerá el mensaje "CLEAR" con el número de archivo y el principio del texto almacenado o invocado más recientemente.  
 Para abandonar la función de **borrado de la memoria** sin borrar el archivo de texto, mantenga pulsada  y presione  (o presione simplemente .
- 2 Presione una tecla numérica (o presione  o ) para seleccionar el número de archivo que contenga el texto que quiera borrar. Se mostrará el texto almacenado en el número de archivo seleccionado.  
 Para ver otras partes del archivo de texto seleccionado, presione  o .  
Para hacer que se visualice el texto almacenado en otros números de archivos, presione  o , o la tecla correspondiente a otro número de archivo.
- 3 Presione . Aparecerá el mensaje "OK TO CLEAR?".  
 Para retroceder y seleccionar un archivo de texto diferente, presione .
- 4 Para borrar el archivo de texto seleccionado, presione .





## SOLUCIÓN DE PROBLEMAS

Problema	Remedio
1. La pantalla se queda en blanco después de haber conectado la alimentación de la máquina.	<ul style="list-style-type: none"> <li>• Compruebe que el adaptador de CA esté correctamente enchufado.</li> <li>• Si está empleando pilas alcalinas, compruebe que estén correctamente insertadas.</li> <li>• Si las pilas están gastadas, reemplácelas por otro nuevo.</li> </ul>
2. La máquina no imprime o los caracteres impresos quedan borrosos.	<ul style="list-style-type: none"> <li>• Compruebe que el casete de cinta se haya insertado correctamente.</li> <li>• Si el casete de cinta está vacío, reemplácelo por otro nuevo.</li> <li>• Asegúrese de que la cubierta del casete de cinta se haya cerrado.</li> </ul>
3. Los archivos de texto almacenados en la memoria ya no están ella.	<ul style="list-style-type: none"> <li>• Si las pilas están gastadas, reemplácelas por otro nuevo.</li> </ul>
4. Los caracteres impresos no se forman correctamente.	<ul style="list-style-type: none"> <li>• Si está empleando pilas alcalinas, quizás estén gastadas. Pruebe utilizando el adaptador de CA o reemplace las pilas por otras nuevas.</li> </ul>
5. Aparece una línea horizontal en blanco a través de la etiqueta impresa.	<ul style="list-style-type: none"> <li>• Limpie el cabezal de impresión como se ha explicado en la página 6.</li> </ul>
6. Aparecen franjas.	<ul style="list-style-type: none"> <li>• Se ha terminado la cinta. Reemplace el casete de cinta por otro nuevo.</li> </ul>
7. La máquina se ha “bloqueado” (es decir, no responde cuando se presiona una tecla).	<ul style="list-style-type: none"> <li>• Desconecte la alimentación de la máquina, y entonces, mientras mantiene presionado  y , vuelva a conectar la alimentación.</li> </ul> <p>El texto y los formatos del visualizador y todos los archivos de texto almacenados en la memoria quedan borrados.</p>

## LISTA DE MENSAJES DE ERROR

Mensaje de error	Causa	Remedio
<b>4 LINE LIMIT!</b>	Este mensaje aparecerá si ya existen cuatro líneas cuando presione  .	Límite el número de líneas a cuatro.
<b>BATTERIES WEAK!</b>	Este mensaje aparece cuando las pilas alcalinas instaladas están gastadas.	Reemplace las pilas o emplee el adaptador de CA.
<b>BUFFER EMPTY!</b>	<ul style="list-style-type: none"> <li>Este mensaje aparece si mantiene pulsada  y presiona  <sup>Length</sup>, pero sin haber introducido texto en el visualizador.</li> </ul>	<ul style="list-style-type: none"> <li>Introduzca algo de texto antes de iniciar la función.</li> </ul>
	<ul style="list-style-type: none"> <li>Este mensaje aparecerá si intenta imprimir sin haber introducido texto en el visualizador.</li> </ul>	<ul style="list-style-type: none"> <li>Introduzca texto antes de imprimir.</li> </ul>
<b>BUFFER FULL!</b>	Este mensaje aparecerá si intenta introducir un carácter, símbolo, espacio o cambiar de línea cuando ya haya sido introducido el número máximo de caracteres.	Borre algo del texto existente para poder introducir más texto.
<b>CAN'T HERE</b>	Este mensaje aparecerá cuando mantenga presionada  y presione  <sup>Number</sup> si el cursor está al final del texto.	Ponga el cursor debajo de un número antes de mantener presionada  y presionar  <sup>Number</sup> .
<b>CHANGE ADAPTOR!</b>	Este mensaje aparece si se está empleando un adaptador de alta tensión.	Desconecte el adaptador de alta tensión y conecte el adaptador diseñado exclusivamente para esta máquina.
<b>CUTTER ERROR!</b>	Este mensaje aparecerá cuando intente imprimir o avanzar la cinta estando cerrado el cortador de cinta.	Suelte la palanca del cortador de cinta.

Mensaje de error	Causa	Remedio
<b>INVAL. CHRS!</b>	Este mensaje aparecerá si el cursor está al final del texto cuando man- tenga pulsada  y presione  .	Mueva el cursor hasta debajo del número manteniendo pul- sada  y presionando  .
<b>LENGTH LIMIT!</b>	<ul style="list-style-type: none"> <li>• Este mensaje aparece si el texto es más largo de 3'3 1/3" (1 metro) cuando trate de imprimirlo.</li> <li>• Este mensaje aparecerá si utilizó la función de <b>longitud</b> para ajustar una longitud inferior a 1,6" (4,0 cm) o más de 11,8" (30,0 cm).</li> <li>• Este mensaje aparecerá si utilizó la función de <b>longitud de tabulaciones</b> para ajustar una longitud superior a 11,8" (30,0 cm).</li> </ul>	<ul style="list-style-type: none"> <li>• Acorte el texto a menos de 3'3 1/3" (1 metro) antes de tratar imprimir.</li> <li>• Ajuste la longitud de la etiqueta entre 1,6" (4,0 cm) y 11,8" (30,0 cm).</li> <li>• Ajuste la longitud de las tabulaciones de forma que sea inferior a 11,8" (30,0 cm).</li> </ul>
<b>LINE LIMIT!</b>	Este mensaje aparece si el número de líneas del texto es mayor que el número máximo de líneas posible para la cinta instalada.	Reduzca el número de líneas o instale una cinta más ancha.
<b>MEMORY FULL!</b>	Este mensaje aparecerá si intenta almacenar un archivo de texto después de haber almacenado el número máximo de caracteres.	Borre un archivo que no desee para dejar espacio para el nuevo.
<b>NO FILES!</b>	Este mensaje aparece si intenta llamar o borrar un archivo de texto de la memoria cuando realmente no hay ninguno almacenado.	Almacene primero un archivo de texto.

Mensaje de error	Causa	Remedio
<b>NO TAPE!</b>	Este mensaje aparecerá si intenta imprimir una etiqueta o alimentar cinta cuando haya casete de cinta instalado.	Instale un casete de cinta y pruebe de nuevo.
<b>REPLACE BATTERIES!</b>	Este mensaje aparece cuando las pilas alcalinas instaladas están casi gastadas.	Reemplace las pilas o emplee el adaptador de CA.
<b>ROM PROBLEM!</b>	Este mensaje aparece si hay algún problema con la memoria de acceso aleatorio de la máquina.	Póngase en contacto con su representante de servicio. Desconecte la alimentación de la máquina, y entonces, mientras mantiene presionado  y  , vuelva a conectar la alimentación.
<b>TAB LIMIT!</b>	Este mensaje aparecerá si ya se ha añadido el número máximo de tabulaciones al texto cuando mantenga presionada  y presione  .	Limite el número de tabulaciones del texto a 50.
<b>TEXT TOO HIGH!</b>	Este mensaje aparece si el tamaño del texto es más grande que el ancho de la cinta instalada.	Reduzca el tamaño de los caracteres o instale una cinta más ancha.
<b>TEXT TOO LONG!</b>	Este mensaje aparece si la longitud del texto es mayor que la longitud que se ha ajustado para la etiqueta utilizando la función de <b>longitud</b> .	Borre algo de texto, reduzca el ancho de los caracteres o incremente la longitud ajustada de la etiqueta.

**¡SI TUVIERA ALGÚN PROBLEMA CON SU PRODUCTO,  
LE ROGAMOS QUE NO DEVUELVA  
EL PRODUCTO A LA TIENDA!**

Después de referirse a la Guía del usuario, si todavía necesita asistencia, refiérase a la información de contacto con Brother de esta guía.

## ESPECIFICACIONES

### HARDWARE

- Dispositivo de entrada:** Teclado de 51 teclas
- LCD:** 10 caracteres x 2 líneas  
20 indicadores (incluidos **Alt** y **Caps**)
- Cinta de impresión:** Sensible a la presión, base adhesiva, 26'3" (8 m) de longitud  
Cinco anchos disponibles:  
1/4" (6 mm)  
3/8" (9 mm)  
1/2" (12 mm)  
3/4" (18 mm)
- Alimentación:** Seis pilas alcalinas AA (AM3, LR6), o adaptador de CA opcional  
Desconexión automática de la alimentación si no se pulsa ninguna tecla durante 5 minutos
- Cabezal de impresión:** 112 puntos / 180 dpi
- Dimensiones:** 7 1/8" (W) x 9 5/32" (D) x 2 1/8" (H)  
(181 x 232,5 x 61,4 mm)
- Peso:** 0,8 lbs (363,6 g) (sin casete de cinta ni pilas instalados)

### SOFTWARE

- Tamaño de la memoria intermedia:** Máximo de 91 caracteres  
Máximo de cuatro líneas
- Tamaño de la memoria:** Aprox. 300 caracteres
- Tamaño de caracteres:** Seis tamaños (6, 9, 12, 18, 24, 36 y 42 puntos) + 52 puntos (letras mayúsculas solamente en cintas de 3/4" (18 mm) de ancho)  
Todos disponibles en achura normal y ancha  
La disponibilidad dependerá del ancho de cinta.
- Estilos de impresión:** Normal, Bold, Outline, Shadow (todos pueden combinarse con cursiva), y Vertical

### INFORMACIÓN IMPORTANTE SOBRE LA GARANTÍA

Muchas gracias por la adquisición de este producto Brother.

Esperamos que disfrute utilizándolo. Le sugerimos que guarde el cartón de embalaje y todos los demás materiales.

Consulte la garantía de su producto para ver detalles.



## ACCESORIOS

### ● Accesorios de consumo

Adquiera los casetes de cinta en el distribuidor autorizado que le quede más cerca. Emplee sólo cintas Brother TZ con esta máquina. **Brother no puede hacerse responsable por los problemas causados por el empleo de accesorios de consumo no autorizados.** No emplee cintas que no tengan la marca .

N.º de producto	Descripción	CANT./PAQUETE	PRECIO**
Cintas laminadas de 3/4" (18 mm)			
TZ-141	Caracteres negros sobre fondo transparente	1	\$18.99
TZ-145	Caracteres blancos sobre fondo transparente	1	\$20.99
TZ-241	Caracteres negros sobre fondo blanco	1	\$20.99
TZ-242	Caracteres rojos sobre fondo blanco	1	\$20.99
TZ-243	Caracteres azules sobre fondo blanco	1	\$20.99
TZ-344	Caracteres dorados sobre fondo negro	1	\$23.99
TZ-345	Caracteres blancos sobre fondo negro	1	\$23.99
TZ-441	Caracteres negros sobre fondo rojo	1	\$20.99
TZ-541	Caracteres negros sobre fondo azul	1	\$20.99
TZ-545	Caracteres blancos sobre fondo azul	1	\$23.99
TZ-641	Caracteres negros sobre fondo amarillo	1	\$20.99
TZ-741	Caracteres negros sobre fondo verde	1	\$20.99
*TZ-B41	Caracteres negros sobre fondo naranja fluorescente	1	\$24.99
TZ-M41	Caracteres negros sobre fondo claro (MATE)	1	\$20.99
TZ-WB41	Caracteres negros sobre fondo Bugs Bunny	1	\$23.99
TZ-WT41	Caracteres negros sobre fondo Taz	1	\$23.99
TZ-WS41	Caracteres negros sobre fondo Tweety & Sylvester	1	\$23.99
TZ-S141	Industrial (adhesivo fuerte) caracteres negros sobre fondo transparente	1	\$21.99
TZ-S241	Industrial (adhesivo fuerte) caracteres negros sobre fondo blanco	1	\$21.99
Cintas laminadas de 1/2" (12 mm)			
TZ-131	Caracteres negros sobre fondo transparente	1	\$16.99
TZ-231	Caracteres negros sobre fondo blanco	1	\$17.99
TZ-232	Caracteres rojos sobre fondo blanco	1	\$17.99
TZ-334	Caracteres dorados sobre fondo negro	1	\$20.99
TZ-335	Caracteres blancos sobre fondo negro	1	\$20.99
TZ-631	Caracteres negros sobre fondo amarillo	1	\$17.99

\* 5 metros (16.4 ft) de largo

<b>N.º de producto</b>	<b>Descripción</b>	<b>CANT./ PAQUETE</b>	<b>PRECIO**</b>
TZ-S131	Industrial (adhesivo fuerte) caracteres negros sobre fondo transparente	1	\$18.99
TZ-S231	Industrial (adhesivo fuerte) caracteres negros sobre fondo blanco	1	\$18.99
Cintas laminadas de 3/8" (9 mm)			
TZ-121	Caracteres negros sobre fondo transparente	1	\$14.99
TZ-221	Caracteres negros sobre fondo blanco	1	\$16.99
TZ-325	Caracteres blancos sobre fondo negro	1	\$18.99
TZ-421	Caracteres negros sobre fondo rojo	1	\$16.99
TZ-S121	Industrial (adhesivo fuerte) caracteres negros sobre fondo transparente	1	\$17.99
TZ-S221	Industrial (adhesivo fuerte) caracteres negros sobre fondo blanco	1	\$17.99
Cintas laminadas de 1/4" (6 mm)			
TZ-111	Caracteres negros sobre fondo transparente	1	\$12.99
TZ-211	Caracteres negros sobre fondo blanco	1	\$14.99
TZ-315	Caracteres blancos sobre fondo negro	1	\$17.99
TZ-S111	Industrial (adhesivo fuerte) caracteres negros sobre fondo transparente	1	\$15.99
TZ-S211	Industrial (adhesivo fuerte) caracteres negros sobre fondo blanco	1	\$15.99

#### Cintas especiales

<b>N.º de producto</b>	<b>Descripción</b>	<b>CANT./ PAQUETE</b>	<b>PRECIO**</b>
TZ-SE4	Caracteres negros sobre cinta de seguridad de 3/4" (18 mm)	1	\$29.99
TZ-FA3	Caracteres azules sobre cinta de tela de 1/2" (12 mm)	1	\$24.99

#### Juego de membretes

<b>N.º de producto</b>	<b>Descripción</b>	<b>CANT./ PAQUETE</b>	<b>PRECIO**</b>
SK-MB	Juego para hacer sellos para sello con tinta negra medio	1	\$37.99
SH-MB	Estampador adicional para sello con tinta negra medio	1	\$24.99

## Opciones

<b>N.º de producto</b>	<b>Descripción</b>	<b>CANT./ PAQUETE</b>	<b>PRECIO**</b>
TZ-CL4	Limpiador de cabezales	1	\$20.99
AD-60	Adaptador de CA	1	\$24.99
6994	Caja de transporte protectora	1	\$29.99

- Para adquirir accesorios vía Internet, le rogamos que visite el sitio Web:  
<http://www.brothermall.com>

\*\* Los precios son solamente para clientes en EE.UU.

# ÍNDICE ALFABÉTICO

<b>A</b>	
Adaptador de CA .....	3
Adición	
líneas nuevas.....	9
tabulaciones.....	10
Alineación .....	21
Almacenamiento.....	26
Anchura .....	17
<b>B</b>	
Borrado.....	27
caracteres.....	11
líneas de texto .....	12
todo el texto .....	12
<b>C</b>	
Cabezal de impresión .....	6
Caracteres acentuados .....	13
Casete de cinta.....	4
Casete de limpieza del cabezal de impresión..	6
Cinta laminada.....	5
Confirmación .....	9
<b>E</b>	
Especificaciones.....	32
Estilo .....	19
Etiqueta de protección .....	5
<b>F</b>	
Formato .....	15
Formato automático.....	15
Función de Avance .....	24
Función de impresión repetida.....	25
Función de Longitud .....	23
Función de Numeración .....	25
<b>I</b>	
Impresión.....	24
Impresión en modo espejo.....	22
Incremento.....	25
Introducción	
caracteres acentuados .....	13
letras mayúsculas .....	8
símbolos.....	8
tabulaciones.....	10
Invocación .....	27
<b>L</b>	
Letras mayúsculas .....	8
Limpieza	
cabezal de impresión .....	6
máquina.....	1
rodillos.....	6
Líneas de texto .....	9
Longitud de cinta .....	23
Longitud de tabulación .....	10
<b>M</b>	
Marcos.....	20
Márgenes .....	21
Memoria .....	26
Mensajes de error.....	29
Modo mayúsculas .....	8
<b>P</b>	
Palanca corta-cinta .....	4
Pilas.....	2
<b>R</b>	
Reposición .....	12
texto y formatos.....	12
todo el texto .....	12

## **S**

Símbolos .....	14
Sobreescritura .....	26
Solución de problemas.....	28
Subrayado.....	19

## **T**

Tabulaciones.....	10
Tamaño.....	17
Tecla Alt .....	8
Tecla Code.....	8
Tecla de retorno.....	9
Tecla Shift .....	8
Teclas de cursor .....	7
Texto	
alineacións.....	21
ancho.....	17
estilo .....	19
subrayado .....	19
tamaño.....	17
Tipos de caracteres .....	17

## INFORMACIÓN PARA CONTACTAR CON BROTHER

---

### Localización de centros de servicio

---

Si necesita ponerse en contacto con un centro de servicio local, le rogamos que llame al 1-800-284-HELP (4357) para localizar el centro de servicio autorizado más cercano a usted.

Nota: Asegúrese de llamar al centro de servicio antes de hacer la visita.

Los centros de servicio no ofrecen asistencia operacional. Ver "Asistencia operacional".

---

### Asistencia operacional

---

Para asistencia técnica y operacional podrá ponerse en contacto con el Servicio de asistencia postventa de Brother llamando al:

Voz 1-877-4-PTouch, o Fax 1-901-379-1210

---

### Asistencia por Internet

---

Para obtener información sobre el producto y descargar los controladores más recientes:  
<http://www.brother.com>

Para adquirir accesorios y ciertos productos Brother: <http://www.brothermall.com>

---

### Accesorios y suministros

---

Para hacer pedidos de accesorios y suministros Brother con Visa, MasterCard, Discover o American Express, podrá llamar gratis al 1-888-879-3232, o rellenar la hoja de pedidos adjunta con la guía del usuario y enviar ambas caras de la hoja al 1-800-947-1445

Para adquirir accesorios por Internet: <http://www.brothermall.com>

Para hacer pedidos por correo o pagar con cheque, le rogamos que rellene la hoja de pedido de accesorios y la envíe junto con el importe a:

Brother International Corporation  
Attn: Consumer Accessory Division  
P.O. Box 341332  
Bartlett, TN 38133-1332

---

### Sistema de contestación por fax

---

El servicio de asistencia postventa de Brother tiene instalado un sistema de contestación por fax fácil de utilizar para que usted pueda obtener contestación instantánea a las preguntas técnicas más comunes e información sobre todos los productos Brother.

Este sistema está disponible 24 horas al día, 7 días a la semana. Usted podrá utilizar el sistema para recibir la información en cualquier facsímil, no solamente desde el que esté llamando.

Le rogamos que llame al 1-800-521-2846 y siga las indicaciones de voz para recibir instrucciones por fax sobre cómo utilizar el sistema y un índice de los temas que puede recibir por fax.



*La información de contacto es solamente para clientes en EE.UU.*

---



# INFORMACIÓN PARA CONTACTAR CON BROTHER

---

## Localización de centros de servicio

---

Si necesita ponerse en contacto con un centro de servicio local, le rogamos que llame al 1-800-284-HELP (4357) para localizar el centro de servicio autorizado más cercano a usted.

Nota: Asegúrese de llamar al centro de servicio antes de hacer la visita.

Los centros de servicio no ofrecen asistencia operacional. Ver "Asistencia operacional".

---

## Asistencia operacional

---

Para asistencia técnica y operacional podrá ponerse en contacto con el Servicio de asistencia postventa de Brother llamando al:

Voz 1-877-4-PTouch, o Fax 1-901-379-1210

---

## Asistencia por Internet

---

Para obtener información sobre el producto y descargar los controladores más recientes:  
<http://www.brother.com>

Para adquirir accesorios y ciertos productos Brother: <http://www.brothermall.com>

---

## Accesorios y suministros

---

Para hacer pedidos de accesorios y suministros Brother con Visa, MasterCard, Discover o American Express, podrá llamar gratis al 1-888-879-3232, o rellenar la hoja de pedidos adjunta con la guía del usuario y enviar ambas caras de la hoja al 1-800-947-1445

Para adquirir accesorios por Internet: <http://www.brothermall.com>

Para hacer pedidos por correo o pagar con cheque, le rogamos que rellene la hoja de pedido de accesorios y la envíe junto con el importe a:

Brother International Corporation  
Attn: Consumer Accessory Division  
P.O. Box 341332  
Bartlett, TN 38133-1332

---

## Sistema de contestación por fax

---

El servicio de asistencia postventa de Brother tiene instalado un sistema de contestación por fax fácil de utilizar para que usted pueda obtener contestación instantánea a las preguntas técnicas más comunes e información sobre todos los productos Brother.

Este sistema está disponible 24 horas al día, 7 días a la semana. Usted podrá utilizar el sistema para recibir la información en cualquier facsímil, no solamente desde el que esté llamando.

Le rogamos que llame al 1-800-521-2846 y siga las indicaciones de voz para recibir instrucciones por fax sobre cómo utilizar el sistema y un índice de los temas que puede recibir por fax.



*La información de contacto es solamente para clientes en EE.UU.*





**brother®**