

# OPERATION MANUAL

•  
Model  
XL2021  
•

# “IMPORTANT SAFETY INSTRUCTIONS”

When using the sewing machine, basic safety precautions should always be followed, including the following.

“Read all instructions before using.”

## **DANGER** – To reduce the risk of electric shock.

1. The sewing machine should never be left unattended when plugged in. Always unplug this sewing machine from the electric outlet immediately after using and before cleaning.
2. Always unplug before relamping. Replace bulb with same type rated 15 watts.

## **WARNING** – To reduce the risk of burns, fire, electric shock, or injury to persons.

1. Do not allow to be used as a toy. Close attention is necessary when the sewing machine is used by or near children.
2. Use this sewing machine only for its intended use as described in this manual. Use only accessories recommended by the manufacturer as contained in this manual.
3. Never operate this sewing machine if it has a damaged cord or plug, if it is not working properly, if it has been dropped or damaged, or dropped into water. Return the sewing machine to the nearest authorized dealer or service center for examination, repair, electrical or mechanical adjustment.
4. Never operate the sewing machine with any air openings blocked. Keep ventilation openings of the sewing machine and foot controller free from the accumulation of lint, dust, and loose cloth.

5. Never drop or insert any object into any opening.
6. Do not use outdoors.
7. Do not operate where aerosol (spray) products are being used or where oxygen is being administered.
8. To disconnect, turn all controls to the off position, then remove plug from outlet.
9. Do not unplug by pulling on cord. To unplug, grasp the plug, not the cord.
10. Keep fingers away from all moving parts. Special care is required around the sewing machine needle.
11. Always use the proper needle plate. The wrong plate can cause the needle to break.
12. Do not use bent needles.
13. Do not pull or push fabric while stitching. It may deflect the needle causing it to break.
14. Switch the sewing machine off when making any adjustments in the needle area, such as threading needle, changing needle, threading bobbin, or changing presser foot, and the like.
15. Always unplug the sewing machine from the electrical outlet when removing covers, lubricating, or when making any other user servicing adjustments mentioned in the instruction manual.

## “SAVE THESE INSTRUCTIONS”

“This sewing machine is intended for household.”

# CONTENTS

	PAGE
<b>KNOWING YOUR SEWING MACHINE</b> .....	1
Principal parts.....	1
Accessories.....	2
<b>VARIOUS CONTROLS</b> .....	3
Pattern selector.....	3
Stitch length dial.....	5
Reverse sewing button.....	5
Foot controller.....	5
Sew-light.....	5
Free-arm model.....	6
Twin needle.....	6
Changing presser foot.....	7
<b>THREADING THE MACHINE</b> .....	8
Winding the bobbin.....	8
Lower threading.....	9
Upper threading.....	10
To draw up lower thread.....	11
Tension controls.....	12
<b>RELATIVE CHART OF SEWING FABRICS, NEEDLE AND THREAD</b> .....	13
<b>STRAIGHT AND ZIGZAG STITCHING</b> .....	14
Straight stitch.....	14
Zigzag stitch.....	16

	PAGE
<b>BUILT-IN STITCHES</b> .....	17
Blind hem stitch.....	17
Shell tuck.....	18
Overedging stitch.....	18
Elastic stitch.....	19
Scallop stitch.....	20
Double action stitch.....	20
Decorative stitches.....	21
Fagoting stitch.....	21
Feather stitch.....	22
Rick-rack stitch.....	22
<b>BUTTONHOLE AND BUTTON SEWING</b> .....	23
Buttonhole.....	23
Button sewing.....	25
<b>USING ATTACHMENTS AND APPLICATIONS</b> .....	26
Zipper insertion.....	26
Darning.....	27
Applique.....	27
Monogramming and Embroidering.....	28
<b>MAINTENANCE</b> .....	29
Changing the needle.....	29
Changing the bulb.....	30
Cleaning.....	31
Oiling.....	32
Performance check list.....	33
Repacking the machine.....	35
<b>INDEX</b> .....	36

# KNOWING YOUR SEWING MACHINE

## *Principal parts*

- ❶ BOBBIN WINDER DEVICE**  
Winds the lower thread onto the bobbin.
- ❷ SPOOL HOLDER**
- ❸ STITCH LENGTH DIAL**  
Controls the feed of stitches.
- ❹ PRESSER FOOT LEVER**
- ❺ UPPER TENSION CONTROL DIAL**  
Controls the upper tension.
- ❻ EXTENSION TABLE & ACCESSORIES COMPARTMENT**
- ❼ PATTERN INDICATION PANEL**
- ❽ REVERSE SEWING BUTTON**  
Push for reverse stitching.
- ❾ BALANCE WHEEL**  
Turn toward you to lower and raise the needle.
- ❿ CLUTCH RELEASE KNOB**
- ⓫ PATTERN SELECTOR**  
Turn in any direction to select the desired stitch.
- ⓬ FOOT CONTROLLER RECEPTACLE**  
Insert the foot controller plug for operation.
- ⓭ FOOT CONTROLLER**

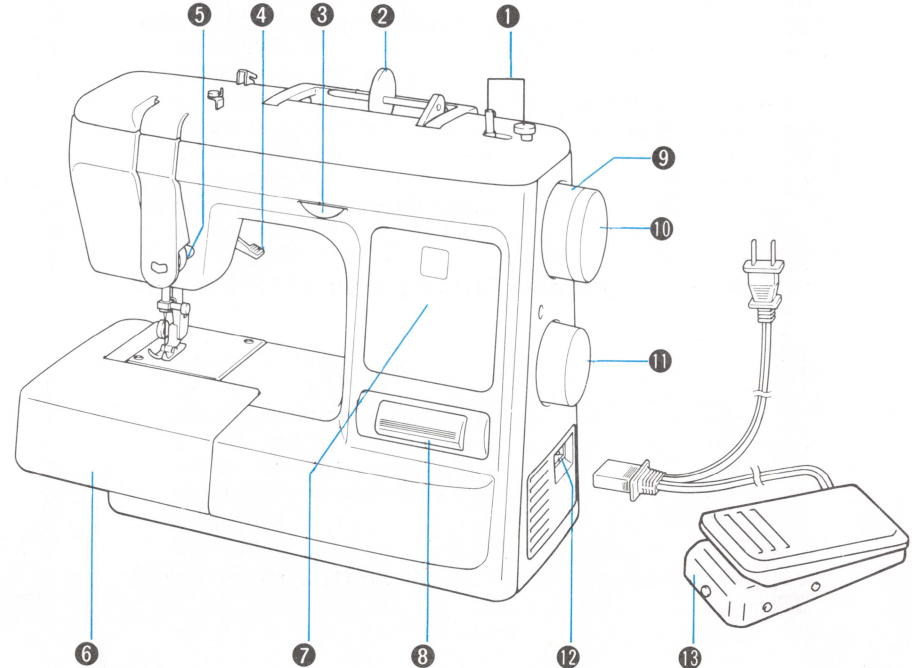

# Accessories

- |                                     |         |              |
|-------------------------------------|---------|--------------|
| ①. Buttonhole Foot                  | 1 pc.   | (Page 23 )   |
| ②. Button Sewing Foot               | 1 pc.   | (Page 25 )   |
| ③. Zipper Foot                      | 1 pc.   | (Page 26 )   |
| ④. Needle Pack                      | 1 set   |              |
| (Regular Single Needle No. 14.....) | 3 pcs.) |              |
| (Twin Needle .....                  | 1 pc. ) |              |
| ⑤. Bobbin                           | 3 pcs.  | (Page 8 )    |
| ⑥. Darning Plate                    | 1 pc.   | (Page 27&28) |
| ⑦. Screw Driver (Large & Small)     | 2 pcs.  | (Page 29&30) |
| ⑧. Extra Spool Pin                  | 1 pc.   | (Page 6 )    |
| ⑨. Spool Holder (Large & Small)     | 2 pcs.  | (Page 8&10)  |

The above accessories are stored in the accessory compartment under the extension table. These accessories have been designed for easy and perfect sewing. For more details, see each page listed.

## Accessory compartment

Lift the extension table up and slide it out.  
Then draw the accessory compartment down pushing its underside.

Parts code for Zigzag stitch foot: 138135051  
Foot controller : J00360051  
Bobbin case : 128582083

The number represents parts code

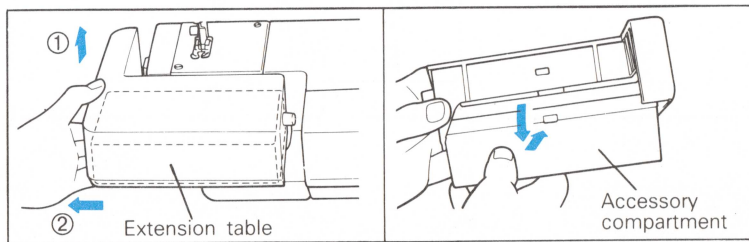
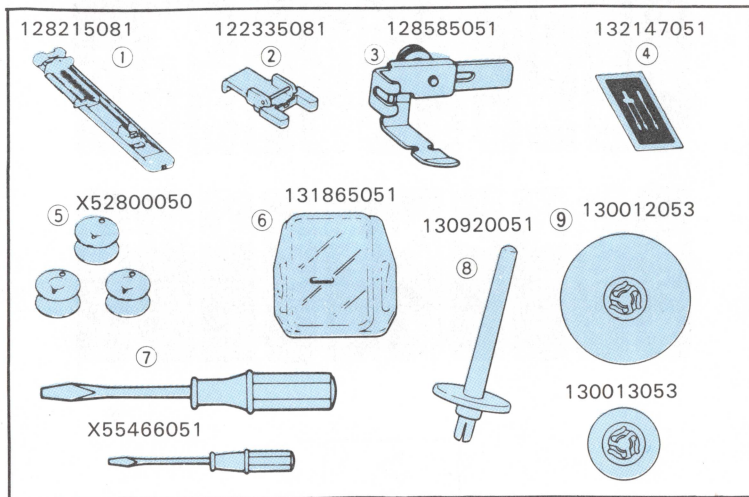

## VARIOUS CONTROLS

### *Pattern selector*

To select a stitch, simply turn the pattern selector located on the end of the machine. All stitches are preset in width, therefore, the stitch length is the only adjustment.

The following table represents the preset width of each stitch and the recommended range of stitch length.

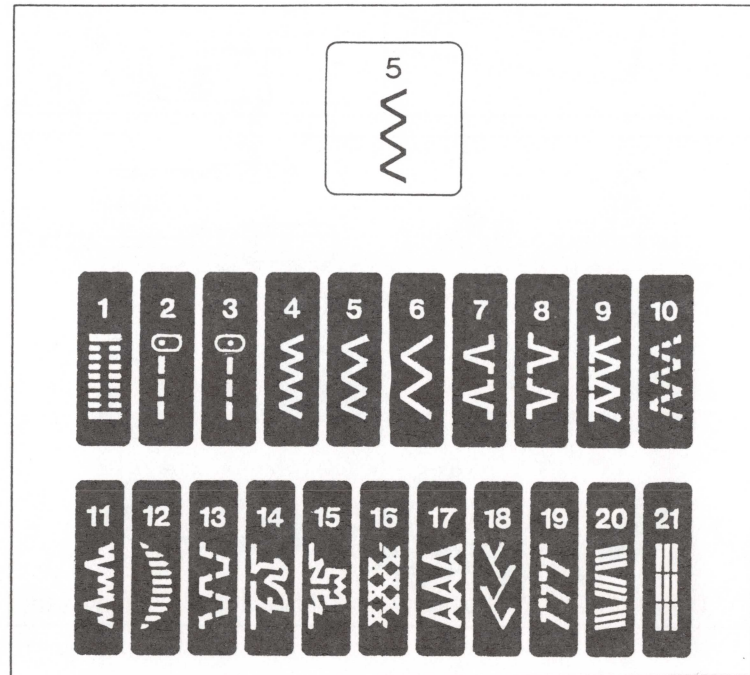
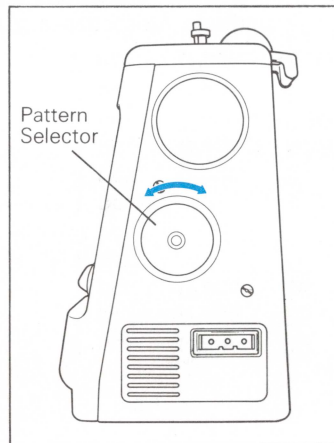

## RECOMMENDED LENGTH

PATTERN	STITCH NAME	PRE-SET WIDTH (MM)	RECOMMENDED LENGTH (MM)	PAGE
1	ONE-STEP BUTTONHOLE	4.8	F-2	23
2	STRAIGHT STITCH (Left needle position)	0	1-4	14
3	STRAIGHT STITCH (Center needle position)	0	1-4	14
4	ZIGZAG STITCH	1.6	F-4	16
5	ZIGZAG STITCH	3.6	F-4	16
6	ZIGZAG STITCH	4.8	F-4	16
7	BLIND HEM STITCH	3	1-2	17
8	SHELL TUCK	4.8	2-4	18
9	ELASTIC OVERLOCK STITCH	4.8	4	18
10	ELASTIC STITCH	4.8	F-2	19
11	GERMAN BLIND STITCH	3.0	1-2	17
12	SCALLOP STITCH	4.8	F-1	20
13	DOUBLE ACTION STITCH	4.8	1-2	20
14	SWAN STITCH	4.8	4	21
15	TULIP STITCH	4.8	4	21
16	FAGOTING STITCH	4.8	4	21
17	ARROW-HEAD STITCH	4.8	4	18
18	FEATHER STITCH	4.8	4	22
19	SLANT OVERLOCK STITCH	4.8	4	18
20	RICK-RACK STITCH	4.8	4	22
21	STRETCH STRAIGHT STITCH	0	4	14

## Stitch length dial

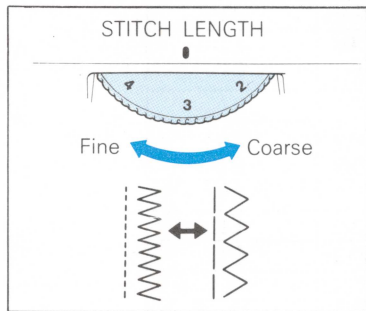

Depending on the stitch selected, you may need to adjust the stitch length.

The numbers marked on the dial represent the stitch length. **THE HIGHER THE NUMBER, THE LONGER THE STITCH.**

The "0" means the material does not feed.

The "F" area is used for making a SATIN stitch (closed stitch) for buttonhole and decorative stitches.

## Reverse sewing button

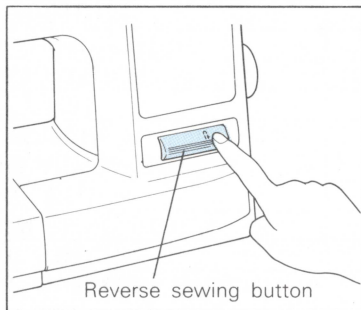

To sew in reverse, push the button as far as it goes. Hold the button in this position until you wish to sew forward. When the button is released, it will spring back in original position and the machine will sew forward. Reverse sewing is used for back-tacking and reinforcement of seams.

## Foot controller

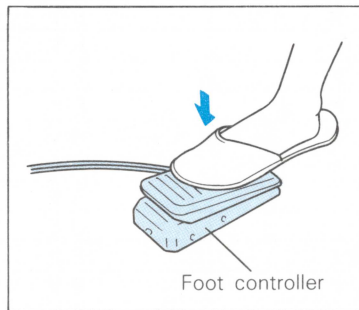

When the foot controller is depressed lightly, the machine will run at a low speed.

When the pressure on the foot controller is increased, the machine will pick up the speed. When the foot controller is released, the machine will stop. Care should be taken that nothing is placed on the foot controller when the machine is not in use.

## Sew-light

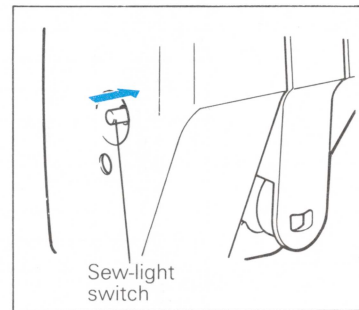

To turn the sew-light on or off, push the sew-light switch.



## Free-arm model

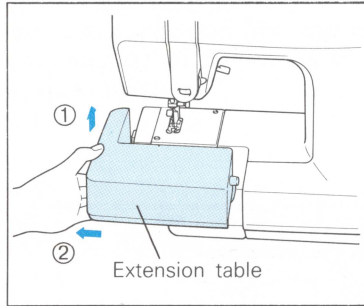

For sewing tubular and hard-to-reach garment areas, free-arm sewing is convenient. To change your machine to a free-arm model, simply lift the extension table then slide it out.

## Twin needle

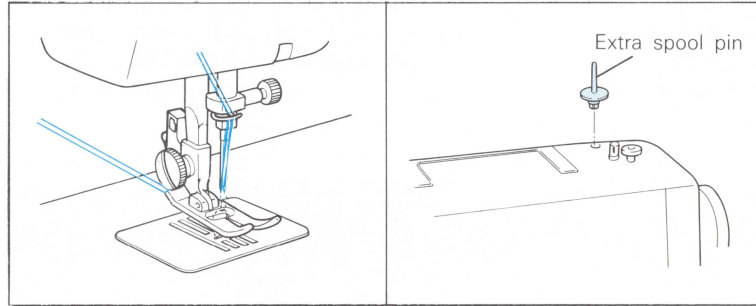

Your sewing machine is designed for twin needle sewing with Straight Stitch (Center) and Stretch Straight Stitch.

### INSERTING TWIN NEEDLE

Insert the twin needle in the same manner as single needle.

### THREADING TWIN NEEDLE

Set the extra spool pin into a hole on the top of the machine. Follow the instructions for single needle threading (See page10), but thread each needle separately.

# Changing presser foot

## (● Buttonhole foot ● Button sewing foot)

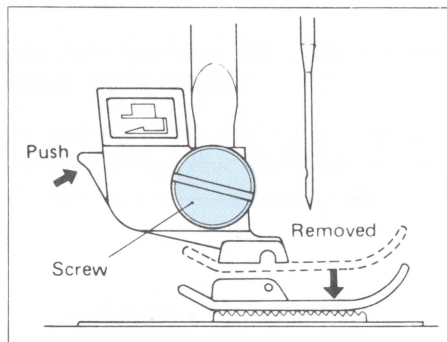
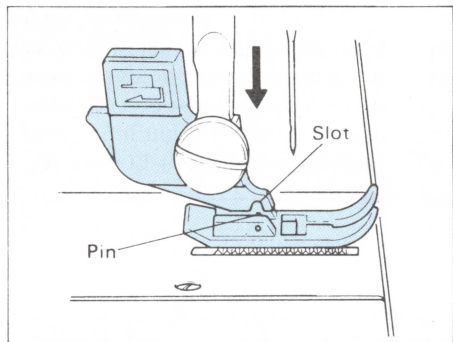

### ● How to attach

Position the foot pin directly below the holder-end and lower the presser foot lever.

### ● How to remove

Raise the presser foot lever and push the button located at the back of the holder to release the foot.

## (● Zipper foot)

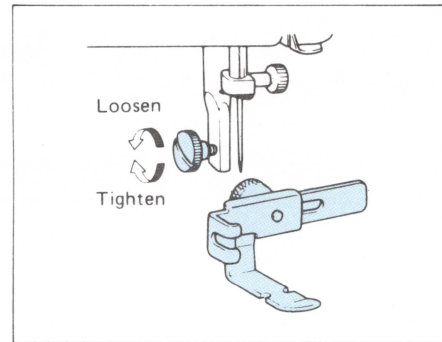

### ● How to remove

Raise the presser foot lever and loosen the screw to remove the holder unit.

### ● How to attach

Attach the zipper foot to the needle bar and fasten the screw.

# THREADING THE MACHINE

## Winding the bobbin

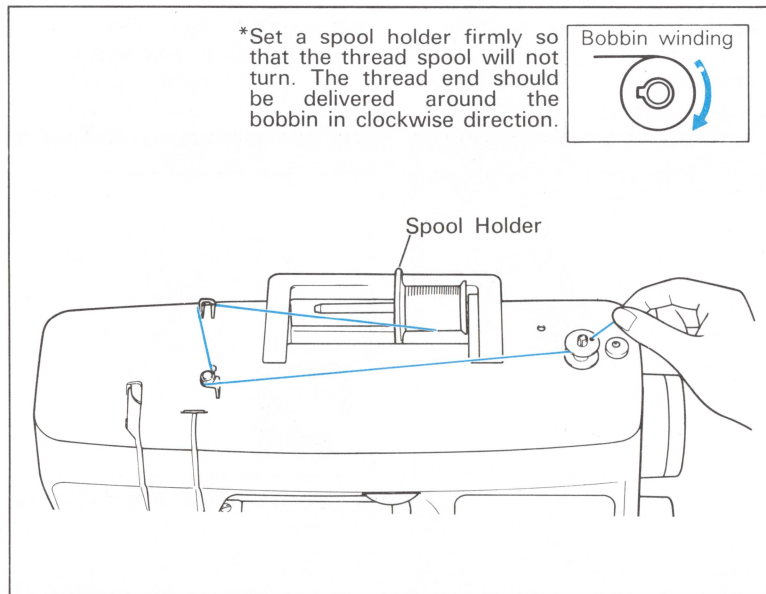

1. Deliver thread through the thread-guides as illustrated.

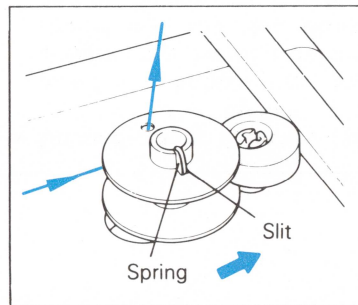

2. Holding the thread end, push the bobbin winder shaft to the right.

\*The slit on the bobbin should match with the spring on the shaft.

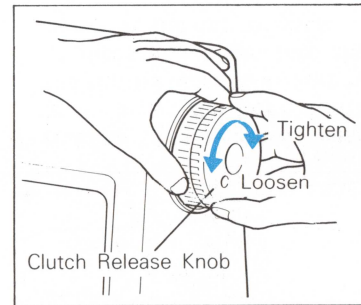

3. Loosen the Clutch Release Knob by turning toward you.

## Winding the bobbin (CONTINUED)

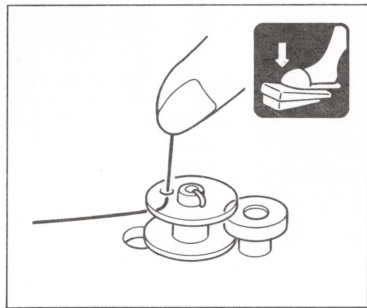

4. Holding the thread end, depress the foot controller to wind the thread. The machine stops automatically when the bobbin is full.

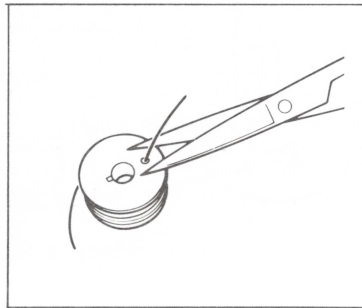

5. Push the shaft to the left. Remove the full bobbin from the shaft, and trim the excess thread. Tighten the clutch release knob securely.

## Lower threading

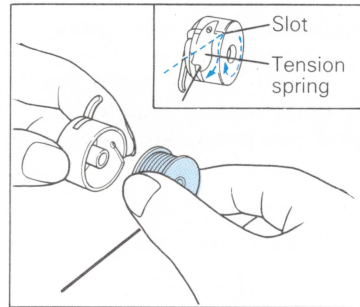

6. Unwind about 4 inches (10 cm) from the bobbin, and insert the bobbin into the bobbin case. Pull the trailing thread into the slot, down and to the left until it enters the delivery eye under the tension spring.

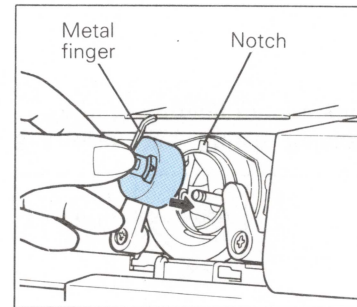

7. Holding the bobbin case latch, insert the bobbin into the shuttle race. Make sure to fit the metal finger into the notch at the top of race.

## Upper threading

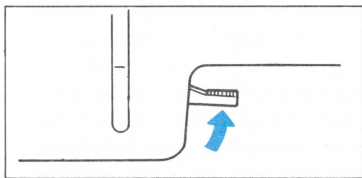

1. Raise the presser foot lever.
2. Raise the needle to its highest position by turning the balance wheel toward you.

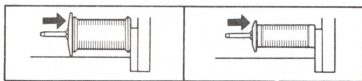

(Large)

(Small)

3. Place a thread spool on horizontal spool pin.
4. Choose an appropriate spool holder according to type and diameter of spool being used. (The diameter of spool holder should be larger than that of the spool itself)
5. Press the spool holder firmly to the spool.

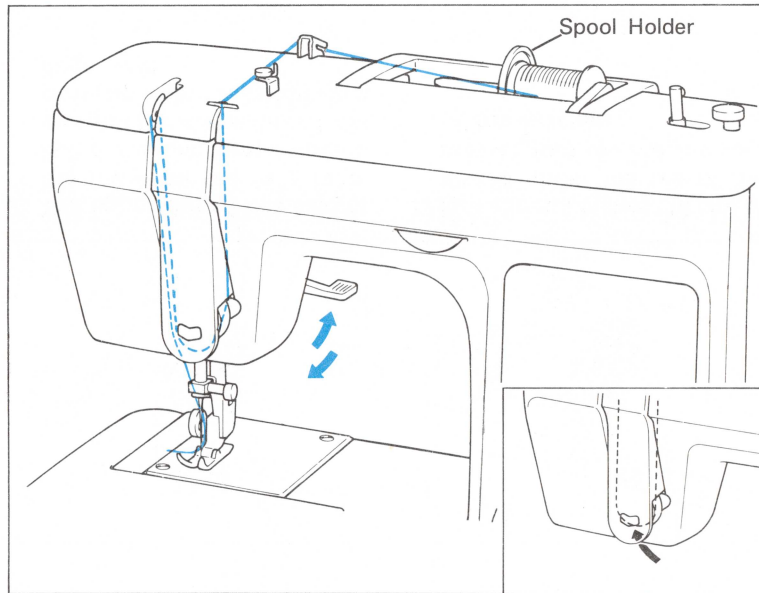

6. Deliver the upper thread as illustrated.

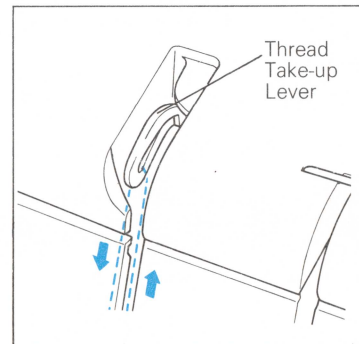

7. Make sure to guide the thread through thread-take-up lever from right to left.

## *To draw up lower thread*

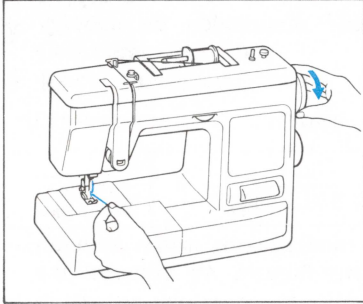

1. Raise the needle and the presser foot to the highest position. With left hand, hold the end of upper thread and with right hand, turn balance wheel toward you until the needle moves down and up again to its highest position.

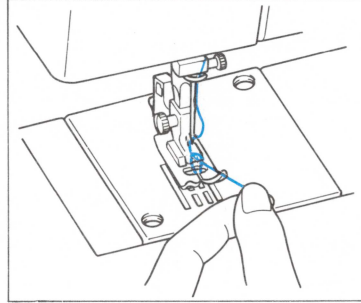

2. The upper thread has caught the lower thread in a loop. Pull the upper thread toward you and the lower thread will come up from the bobbin in a large loop.

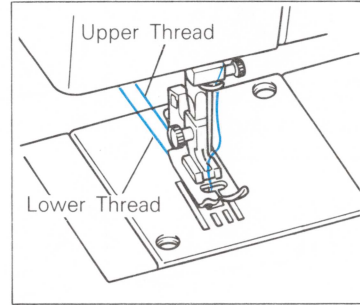

3. Pull about 4 inches (10 cm) of thread under the toe of the presser foot toward the back of the machine.

# Tension controls

## ■ Upper tension is too tight.

Locks appear on the fabric surface.

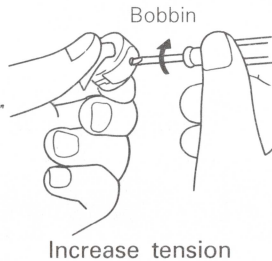
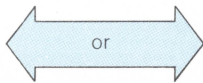
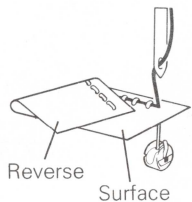

## ■ Upper tension is too loose.

Locks appear on the reverse side of the fabric.

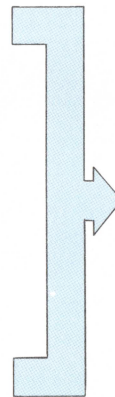
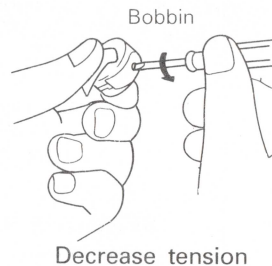
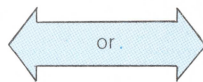
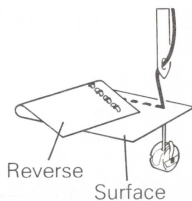

## Correct tension

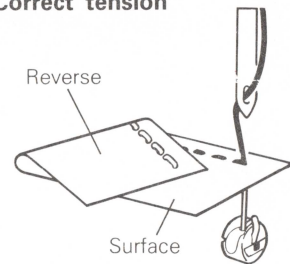

Correct tension is important because too much or too little tension will weaken your seams or cause puckers on your fabric.

## RELATIVE CHART OF SEWING FABRICS, NEEDLE AND THREAD

SEWING MATERIALS		NEEDLE SIZES	THREAD SIZES
VERY THIN	Fine tricot, Fine lace, Thin linen, Silk, Tulle, Chiffon	9	Cotton: 80 Synthetic Fine Mercerized Cotton
LIGHTWEIGHT	Organdy, Jersey, Voile, Taffeta, Synthetics, Silk, Batiste	11	Cotton: 60 ~ 80 Silk: "A" Synthetic Mercerized 50
MEDIUM	Cotton, Gingham, Poplin, Percale, Pique, Satin, Velvet, Lightweight wool, Fine corduroy, Suitings	14	Cotton: 50 ~ 60 Silk: "A" Synthetic Mercerized 50 ~ 60
HEAVY	Denim, Gabardine, Tweed, Corduroy	16	Cotton: 40 ~ 50 Mercerized Heavy Duty

### NOTE:

1. Select the correct needle and thread size from the above chart.
2. Use the same size thread for the upper and lower threads.



## STRAIGHT AND ZIGZAG STITCHING

### *Straight stitch*

Pattern	Stitch Length
2 (Left needle position)	1-4
3 (Center needle position)	
21 (Stretch Straight Stitch)	4

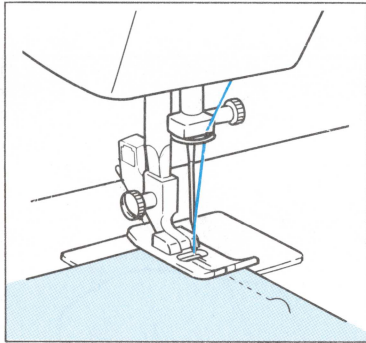

#### **How to Start Sewing**

1. Raise the needle to its highest position and lift the presser foot.

2. Pull up the lower thread by turning the balance wheel toward you and pull both upper and lower thread to the back of presser foot.
3. Place fabric under the presser foot and position needle 3/8 inch (10 mm) beyond fabric edge.
4. Lower the presser foot.
5. To back tack, push the Reverse Sewing Button as far as it goes. Reverse sewing is used for locking end of seam and where reinforcement is needed.
6. Release the Reverse Sewing Button and start sewing in forward direction.

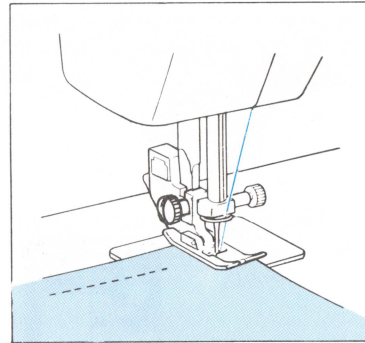

#### **How to Change Sewing Direction**

1. Stop the machine at the turning point while the needle is in the fabric.
2. Raise the presser foot and turn the fabric to its new direction while the needle acts as the axis.
3. Lower the presser foot and start sewing in new direction.

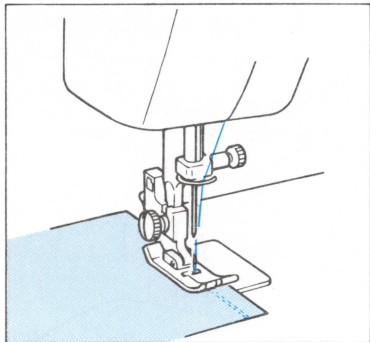

### How to Finish Your Sewing Project

Reverse stitching is used to lock the threads at the end of the seam or wherever reinforcement is needed.

1. This is done by stitching to the end of the seam. Then stop.
2. Push the Reverse Sewing Button and stitch backward for 3/8 inch (10 mm) from end of the seam fabric.

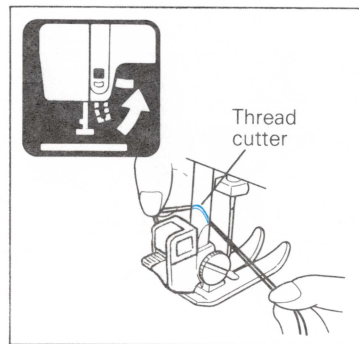

### How to Remove from Machine

1. Stop the machine.
2. Raise the needle to its highest position and make sure that the thread take-up lever is also in the highest position.

3. Lift the presser foot and pull out the fabric gently to the left side.

4. Cut both threads by the thread cutter equipped with the machine.

5. To prepare the machine for the next seam, pull 4 inches (10 cm) of thread between the toe of the presser foot toward the back of the machine.

### Top Stitching and Stretch Materials

No. 2 (Left needle position) is used for Top stitching and sewing light weight fabrics.

No.21 (Stretch Straight Stitch) is for stretchable fabrics.

## Zigzag stitch

Pattern	Stitch Length
4 (Stitch Width at 1.6 mm)	F-4
5 (Stitch Width at 3.6 mm)	
6 (Stitch Width at 4.8 mm)	

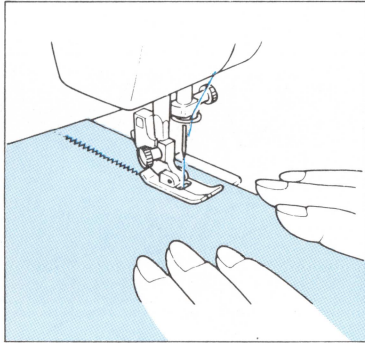

### SIMPLE ZIGZAG STITCHING

Select the Pattern number depending on the width you need and select the stitch length. It is recommended to sew the straight stitch at the beginning and end of zigzag stitches.

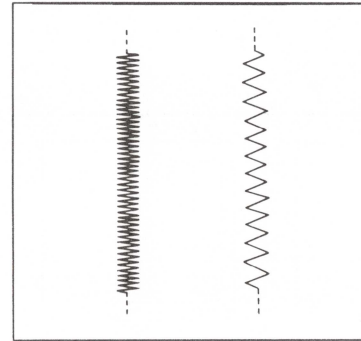

### SATIN STITCH

When stitch length is set at "F" position, it produces the "SATIN STITCH" used for making button-holes or decorative stitches.

## BUILT-IN STITCHES

### *Blind hem stitch*

Pattern	Stitch Length
7 (Blind Hem Stitch)	1-2
11 (German Blind Stitch)	

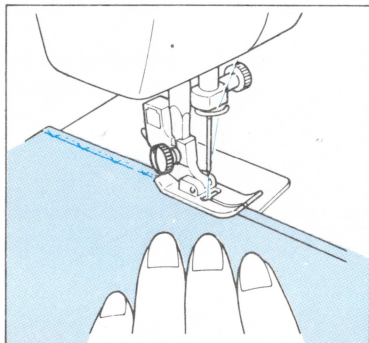

1. Thread used should be the same color as the fabric used.
2. Fold the fabric to the size of hem desired and then fold back as shown in Figure A. Leave 1/4 inch overlap at edge.
3. Sew on the fold as in Figure B.
4. When the fabric is unfolded you will have a blind stitch hem as in Figure C.

**NOTE:** The "German Blind stitch" is useful for stretch fabrics.

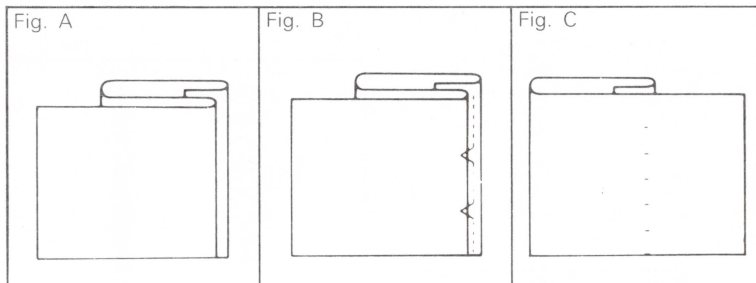

## Shell tuck

Pattern	Stitch Length
8	2-4

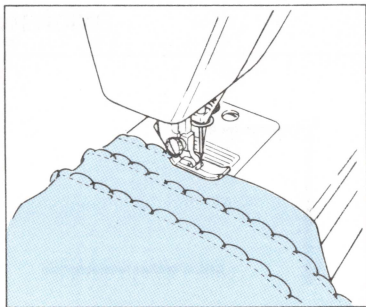

**This stitch can be used for sewing a picot edge on a light weight fabric.**

1. Sew fabric on bias, placing it under the presser foot so that straight stitches are sewn on seam line and zig zag stitches are sewn slightly over folded edge.
2. This work requires a little tighter upper thread tension than normal.
3. Sew at slow speed.
4. Edge of material will be picot-ed.

## Overedging stitch

Pattern	Stitch Length
9 (Elastic Overlock Stitch) 17 (Arrow-Head Stitch) 19 (Slant Overlock Stitch)	4

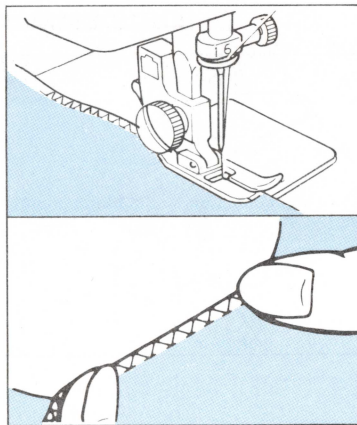

Position the fabric under the presser foot so the right (zig zag) side of the stitch pattern forms along the cut edge of the fabric. The left hand (straight stitch pattern) forms the seam stitching line of approximately 1/4 inch seam allowance. If the seam allowance is wider than the stitch pattern, trim away any excess fabric after stitching.

**NOTE:** When sewing elastic materials, Elastic Overlock Stitch is useful as illustrated.

Pattern	Stitch Length
10 (Elastic Stitch)	F-2

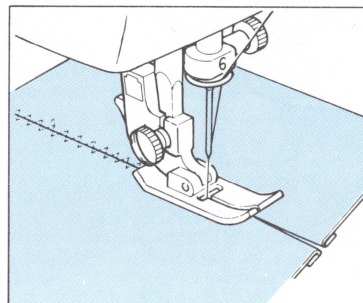
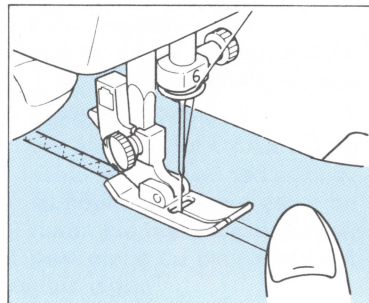
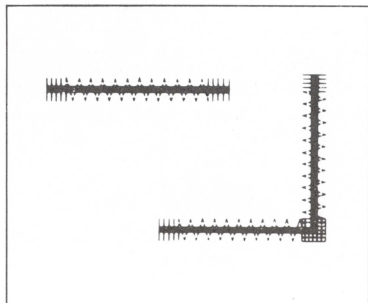

## MENDING

1. Set the stitch Length Dial between F-1.
2. Place reinforcement fabric under tear.
3. Following the line of tear, sew using the elastic to join both sides of the tear.

## SEWING ELASTIC

1. Place the elastic on the fabric.
2. As you sew, stretch elastic both in front and in back of the presser foot as shown in illustration.

## JOINING STITCH

1. The elastic stitch is used to join fabric together.
2. Place fabric edge to edge under the presser foot.
3. Sew together using elastic stitch. Care should be taken to keep the two fabric edges close together.

## Scallop stitch

Pattern	Stitch Length
12	F-1

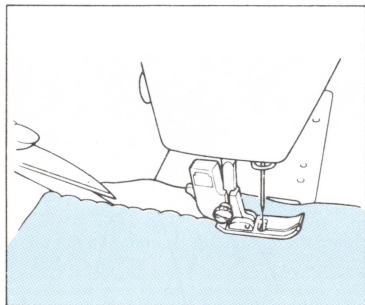

This machine produces decorative stitch (Scallop) automatically.

The "Scallop Stitch" may be used as a decorative edging.

1. Sew scallop stitch along edge of material.
2. If desired, trim around scallop with scissors to create a scallop edge.

## Double action stitch

Pattern	Stitch Length
13	1-2

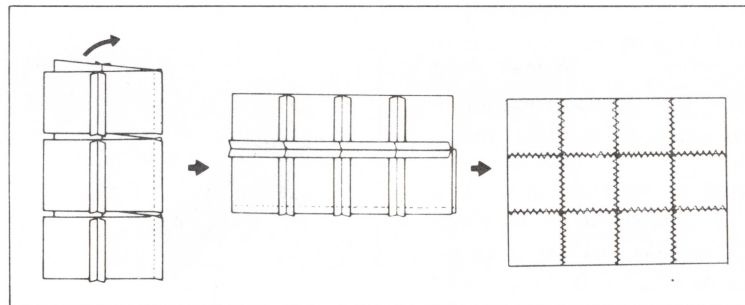

This stitch is used for joining two pieces of fabric, for instance, patch work.

## Decorative stitches

Pattern	Stitch Length
14 (Swan)	4
15 (Tulip)	

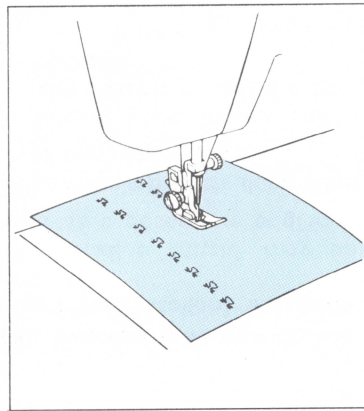
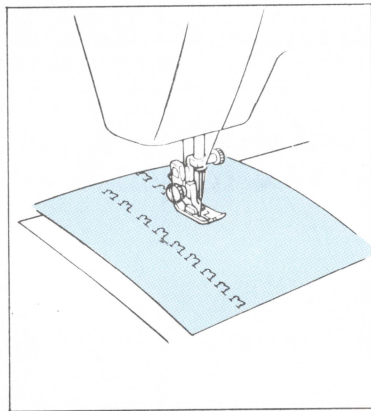

## Fagoting stitch

Pattern	Stitch Length
16	4

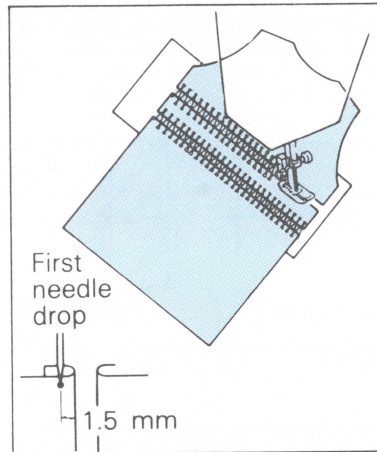

### 1. Basting

Baste edges of fabric to thin paper, leaving a small space between the two pieces.

### 2. Stitch along the edge

Pull both threads slightly when starting.

\* Use thicker threads than for normal sewing.

### 3. After sewing

1) Remove the basting and the paper.

2) Tie knots at the beginning and the end of the seams on the reverse side.



## Feather stitch

Pattern	Stitch Length
18	4

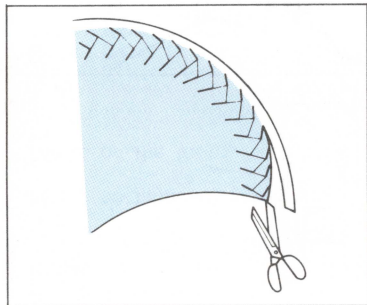

Use this stitch as a hemming stitch for blankets, table-cloths, draperies, embroidery and decorative top stitching. Place the fabric right side up and sew  $\frac{3}{8}$  inch from the edge. Trim close to stitching. The stitch will prevent raveling.

## Rick-rack stitch

Pattern	Stitch Length
20	4

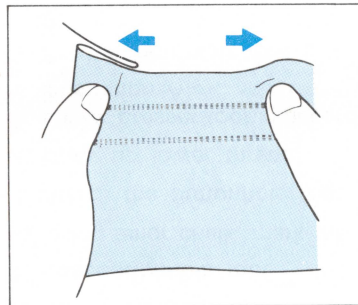

Sew on heavier weight stretch fabrics in any area that you may use a zigzag stitch. This stitch can be used as a decorative top stitch as well.

## Buttonhole

Pattern	Stitch Length	Foot
1	F-2	Buttonhole foot

**NOTE:** It is a good idea to practice making a buttonhole on a scrap of fabric before attempting the actual garment.

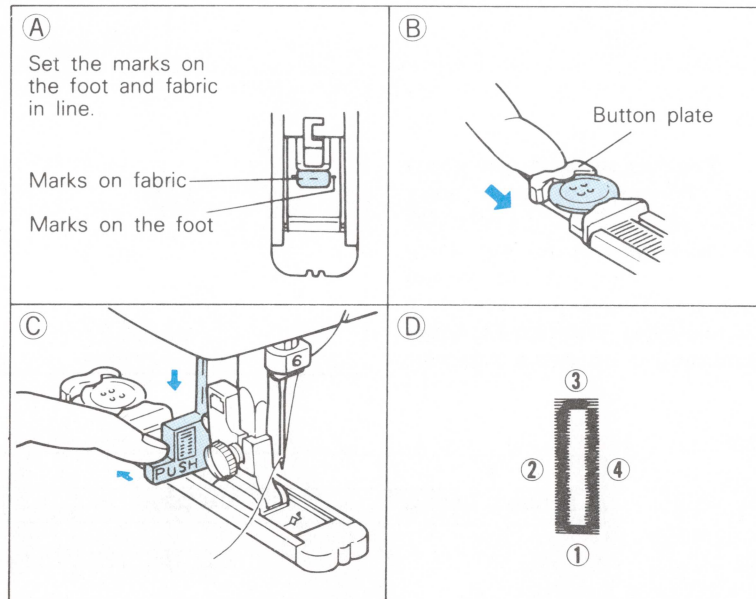

**One-step automatic buttonhole making is a simple process that provides reliable results.**

### MAKING BUTTONHOLE

1. Use buttonhole foot.
2. Using tailor chalk, mark the position of buttonhole on the fabric.
3. Attach the buttonhole foot.
4. Draw up lower thread.
5. Lower presser foot in accordance with the marked line as per the illustration (A).
6. Draw button plate and insert the button as per the illustration (B).
7. Pull down **buttonhole lever** and push this lever back slightly as per the illustration (C).
8. Holding the upper thread gently, start the machine.
9. Buttonhole stitching is made in the orders of 1-4 as per the illustration (D).  
Stop the machine when bar tack is finished.

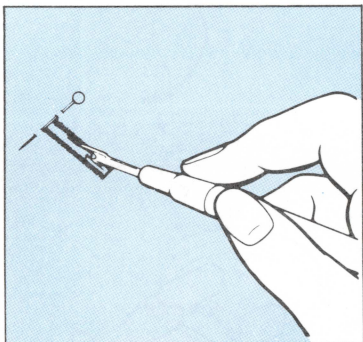

### HOW TO SECURE STITCHING AND CUT MATERIAL FOR BUT- TONHOLE.

1. To secure stitching, turn the material 90 degrees counter-clockwise and sew 5-6 straight stitches.
2. Remove the material from the machine. Cut opening in buttonhole with seam ripper tool. Care should be taken not to cut through any stitching.
3. It is recommended that pins are placed across both ends of buttonhole as a protection against cutting bar tack stitching.

Pattern	Stitch Length	Foot	Others
4 or 5 or 6	Any position	Button Sewing Foot	Darning plate

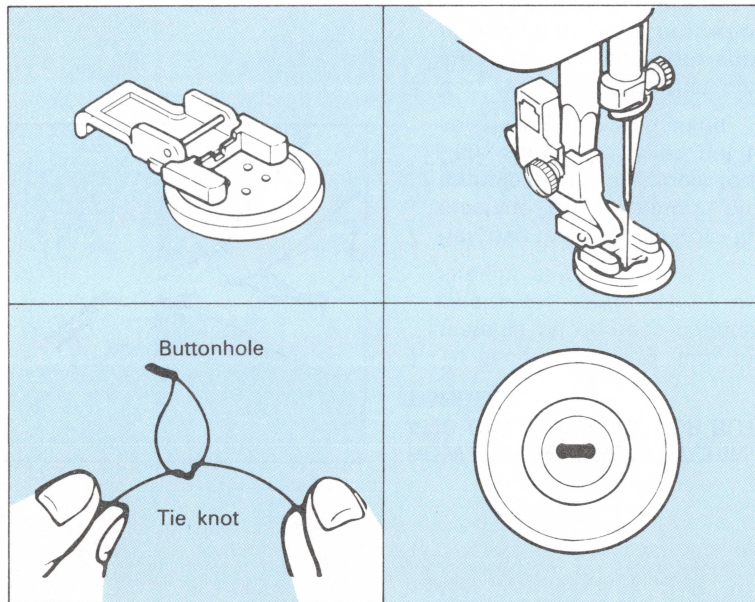

1. Measure the distance between the holes and select the Pattern.

Distance of holes	Pattern
1.6 mm (0.06 inch)	4
3.6 mm (0.14 inch)	5
4.8 mm (0.19 inch)	6

- 2 Change the foot to Button Sewing Foot. Place the Darning Plate on the needle plate.
4. Place a button between the foot and fabric, and make sure that needle enters both holes without hitting the button.
5. At slow speed, sew approximately 10 stitches.
6. Remove the button from the machine. Cut upper and lower threads and tie both threads at back side.

# USING ATTACHMENTS AND APPLICATIONS

## Zipper insertion

Pattern	Stitch Length	Foot
3	2-3	Zipper Foot

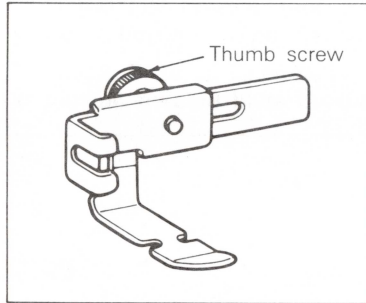

Zipper foot is used to sew various types of zippers and can easily be positioned to right or left side of needle. When zipper is sewn at right side of the needle, place the zipper foot by loosening thumb screw and sliding zipper foot to the left.

When the zipper is sewn at left side of needle, place the zipper foot by loosening thumb screw and sliding zipper foot to the right.

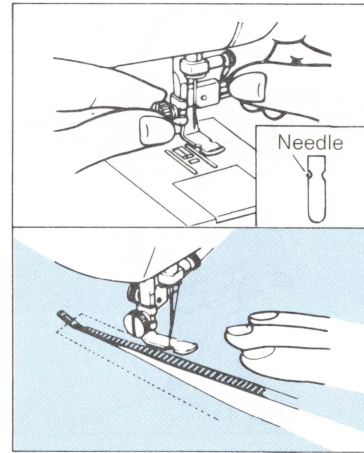

1. Lower needle into side notch located on the presser foot (right or left).
2. Tighten the thumb screw to lock presser foot into position.
3. To sew opposite side of zipper loosen thumb screw and place the zipper foot (right or left.)

## Darning

Pattern	Stitch Length	Others
3	Any position	Darning Plate

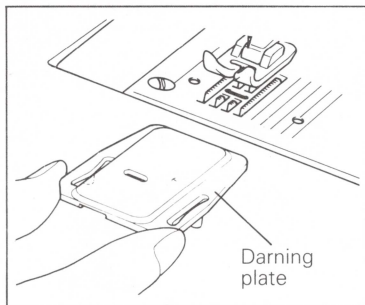

1. Set the darning plate on the needle plate as illustrated.
2. Place portion to be darned under the presser foot together with fabric underlay for reinforcement.
3. Lower the presser foot.

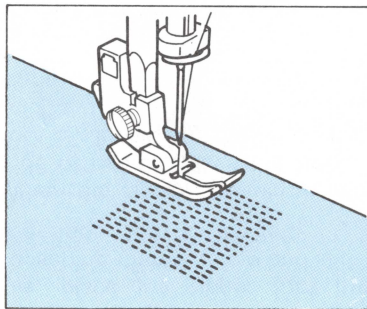

4. Sew alternately drawing the work gently away from you and pulling it toward you.
5. Repeat this motion until the portion to be darned is filled with parallel lines of stitching.

## Applique

Pattern	Stitch Length
4 or 5 or 6	F-2

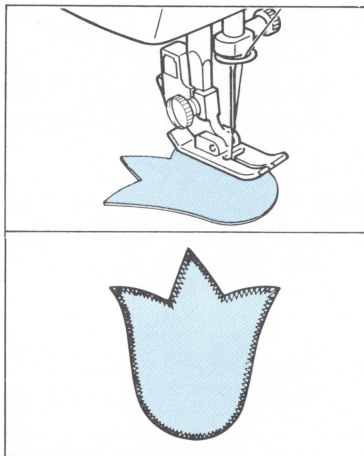

1. Baste the cut design to the fabric.
2. Sew carefully around the edge of the cutout design.
3. Cut away surplus fabric outside of stitching.
4. Remove basting.

**NOTE:** Make reinforcement straight stitches at beginning and the end of the stitches.

# Monogramming and Embroidering

Pattern	Stitch Length	Foot	Others
4 or 5 or 6	At any position	Remove	Darning plate

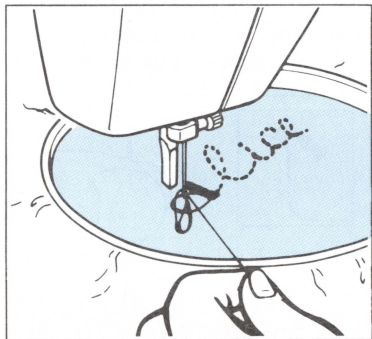

## PREPARATION FOR MONOGRAMMING AND EMBROIDERING

1. Place the darning plate on the needle plate.
2. Set your sewing machine as per the above instructions.

3. Draw lettering (for monogramming) or design (for embroidering) on the right side of the fabric.
4. Stretch work between embroidery hoops as firmly as possible.
5. Place the work under the needle and lower the presser bar.
6. Pull the lower thread up through the work at starting position by turning balance wheel and make a few holding stitches.
6. Hold the hoop with thumb and forefingers of both hands while pressing the fabric with middle and third fingers and supporting the outside of hoop with smaller finger.



## MONOGRAMMING

1. Sew, moving hoop slowly along the lettering at the same speed.
2. Secure with a few straight stitches.

(NOTE: These instructions also apply to embroidering.)

## EMBROIDERING

1. Stitch the outline of the design by moving the embroidery hoop accordingly.
2. Fill in design stitch from the outline of the design to the inside and from inside to edge of the outline alternately until design is completely filled in. Keep stitching close together.

**NOTE:** A long stitch is made by moving the embroidery hoop rapidly and a short stitch is made by moving it slowly.

## MAINTENANCE

### Changing the needle

- Remove the power supply plug from the outlet.

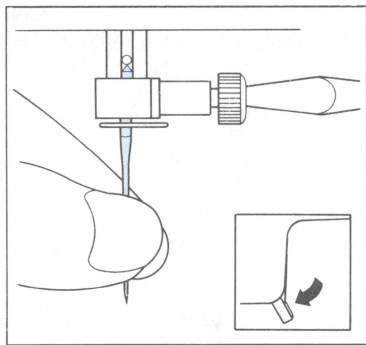

#### 1. Remove the needle

Lower the presser foot and loosen the screw.

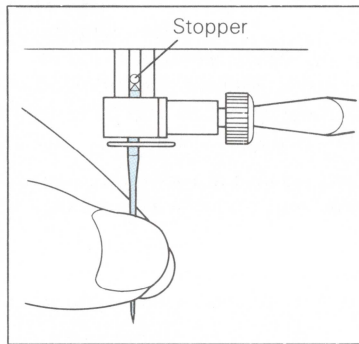

#### 2. Inserting the needle

With the flat side facing back, insert the needle as far as it will go against the needle stopper. Tighten the screw.

- How to check the needle.

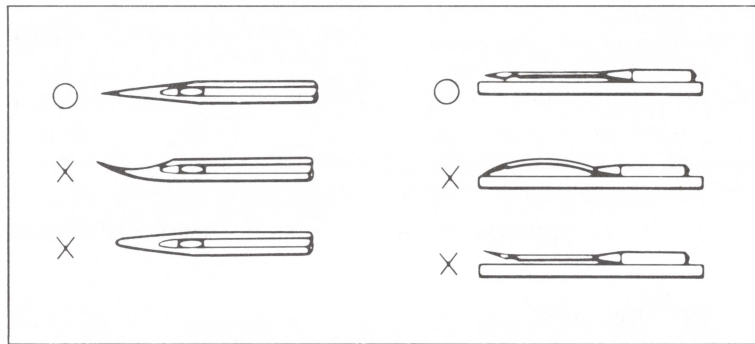

1. The sewing needle must always be straight and sharp for smooth sewing.

2. To check if needle is bent, place flat side of needle down as shown in illustration at right.



## Changing the bulb

- Remove the power supply plug from the outlet.

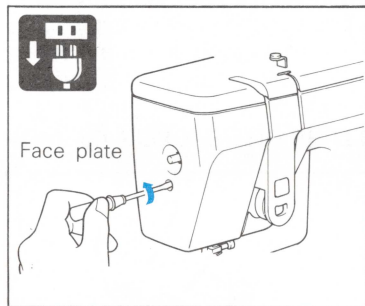

1. Loosen the screw.

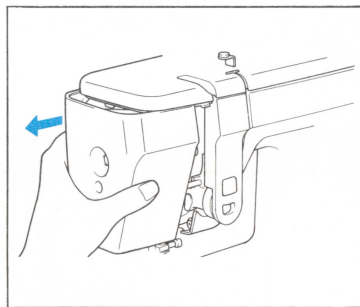

2. Remove the face plate from machine.

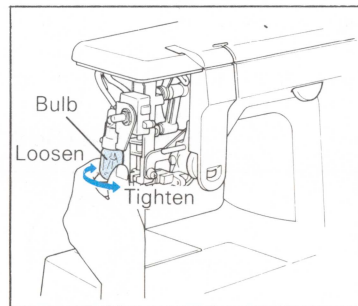

3. Replace the bulb.

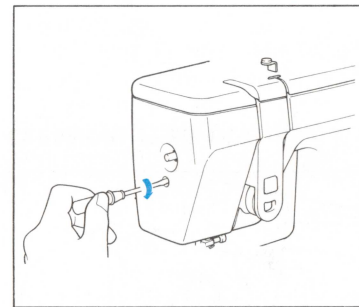

4. Attach the face plate and fasten the screw.

- Remove the power supply plug from the outlet.
- Lint and dust easily accumulate. Always keep clean.

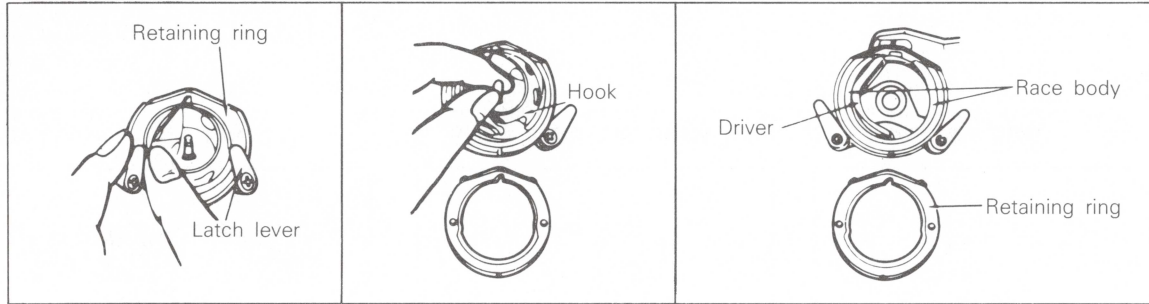

## HOW TO REMOVE THE SHUTTLE HOOK

1. Raise the needle to its highest position.
2. Open the shuttle cover.
3. Take out the bobbin case.
4. Push latch levers outside and remove the retaining ring.
5. Remove the hook by grasping center post of the hook.

NOTE: When needle is lowered, shuttle hook cannot be removed.

## CLEANING SHUTTLE RACE

1. Remove accumulated lint and thread from the retaining ring, hook, driver and race body with brush.
2. A cloth dampened with machine oil should be used to wipe shuttle race clean.
3. Clean shuttle hook in same manner as above.
4. Reassemble and push the latch levers inside.

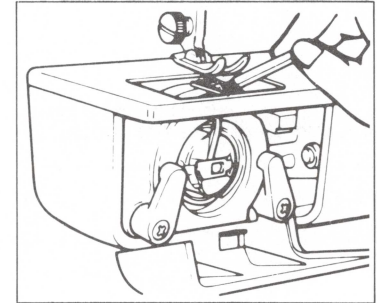

## CLEANING FEED DOG

1. Take out the needle plate.
2. Clean the upper part of feed dog and shuttle race body with a brush.

# Oiling

- Remove the power supply plug from the outlet.
- OIL ONCE A WEEK IF THE MACHINE IS USED MORE THAN ONE HOUR PER DAY.  
IF THE MACHINE IS USED MORE OFTEN OIL EVERY DAY.

- OIL 2 TO 3 DROPS TO THE POINTS MARKED
- After oiling, run the machine fast without thread.
- Be sure to wipe off any excess oil.

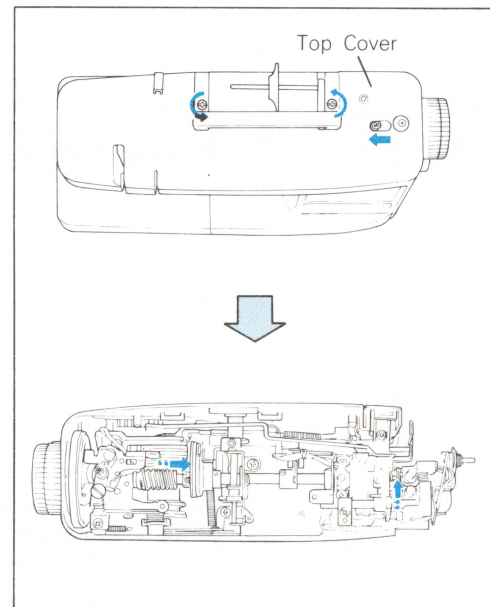
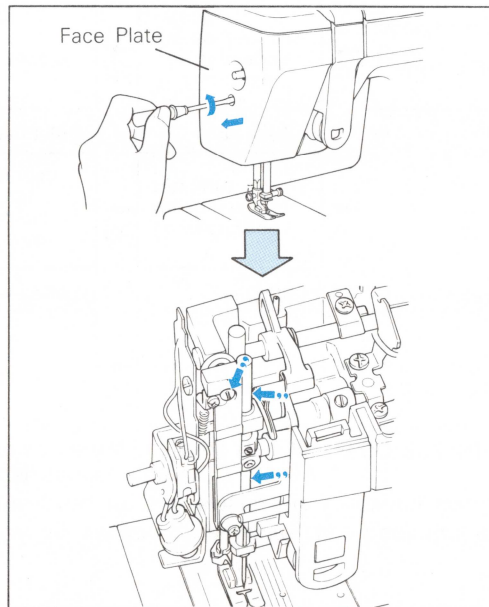
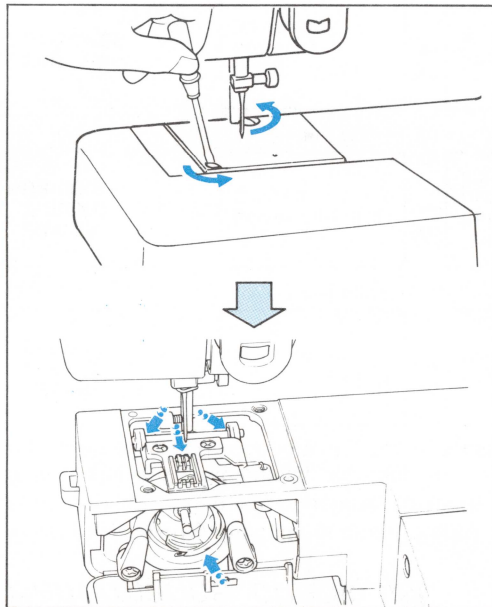

# Performance check list

Whenever sewing difficulty is encountered, review the section of the instruction book that explains the operation you are performing to make sure you are using the machine correctly. If the problem still exists, the following check list may help you correct it.

If you still have difficulties, contact your nearest service center.

For the name and location of your nearest service center, call toll free at 1-800-284-HELP.

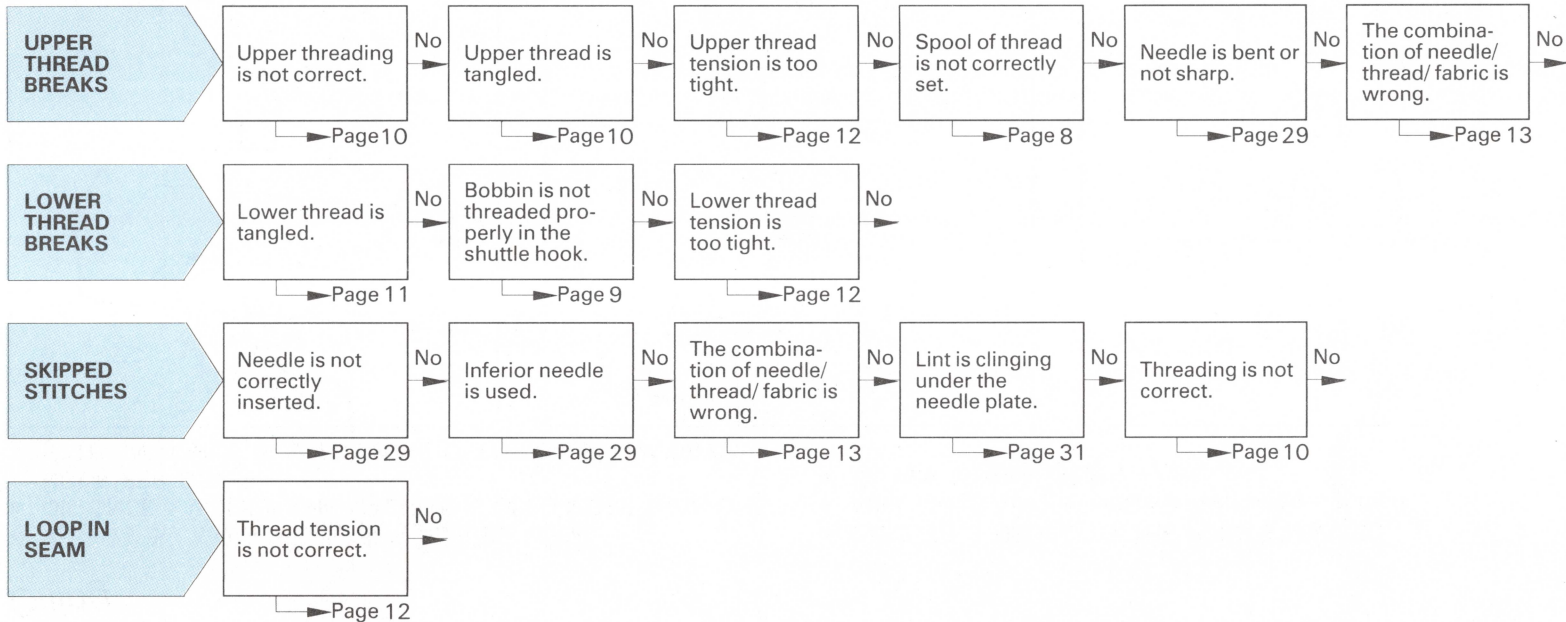

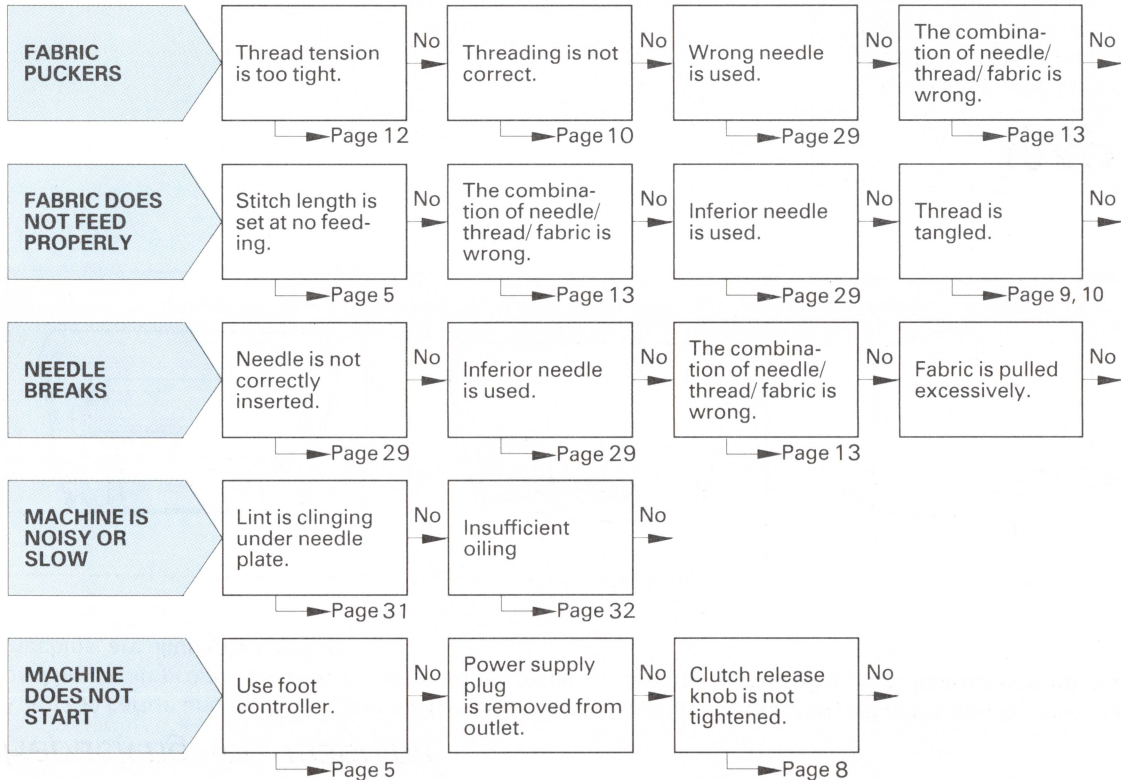

## Repacking the machine

Keep the carton and packing materials for future use when it is necessary to reshipe the sewing machine. Improper packing or improper packing material could result in damage during shipping. Instructions for repacking the machine are illustrated below.

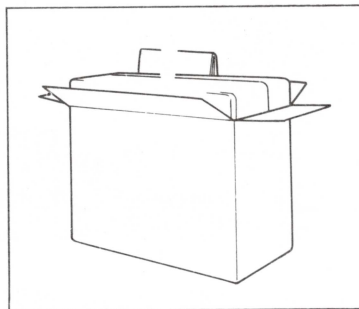
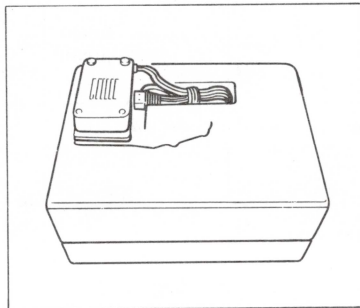
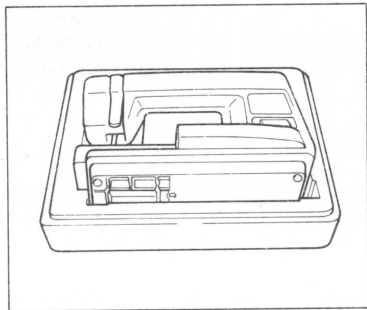

## IMPORTANT

This packing material is designed to prevent damage in transit. Save this packing material in the event you need to transport this sewing machine.

# INDEX

	Page
Accessories .....	2
Applique .....	27
Blind hem stitch .....	17
Button sewing .....	25
Buttonhole .....	23
Changing presser foot .....	7
Changing the bulb .....	30
Changing the needle .....	29
Cleaning .....	31
Darning .....	27
Decorative stitches .....	21
Double action stitch .....	20
Elastic stitch .....	19
Fagoting stitch .....	21
Feather stitch .....	22
Foot controller .....	5
Free-arm model .....	6
Lower threading .....	9
Monogramming and Embroidering .....	28

	Page
Oiling .....	32
Overedging stitch .....	18
Pattern selector .....	3
Performance check list .....	33
Principal parts .....	1
Relative chart of sewing fabrics, needle and thread .....	13
Repacking the machine .....	35
Reverse sewing button .....	5
Rick-rack stitch .....	22
Scallop stitch .....	20
Sew-light .....	5
Shell tuck .....	18
Stitch length dial .....	5
Straight stitch .....	14
Tension controls .....	12
To draw up lower thread .....	11
Twin needle .....	6
Upper threading .....	10
Winding the bobbin .....	8
Zigzag stitch .....	16
Zipper insertion .....	26

INDEX

ENG  
194200-011  
Printed in TAIWAN