

## Operation keys and LCD Teclas de operación y pantalla de LCD

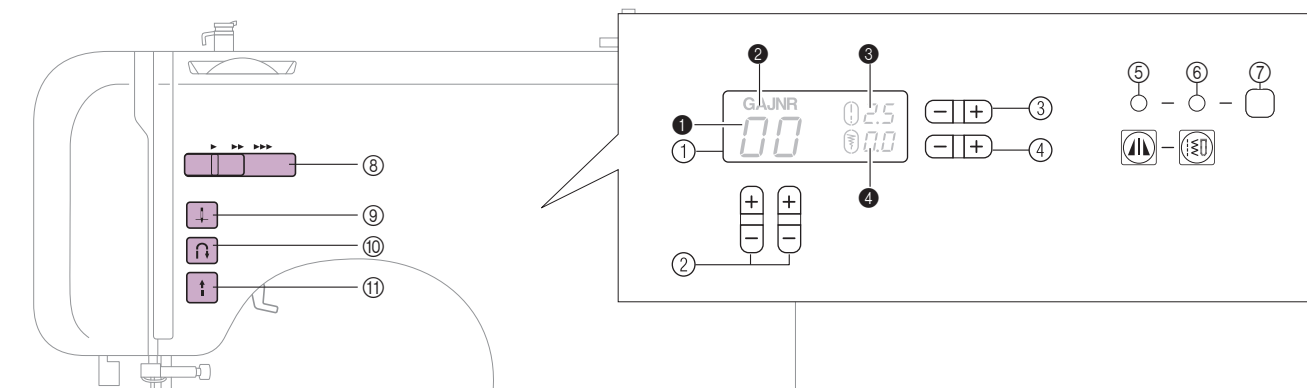

- ① LCD (liquid crystal display)  
① Number of the selected stitch  
② Presser foot to be used  
③ Stitch length (mm)  
④ Stitch width (mm)
- ② Stitch selection keys  
③ Stitch length adjustment key  
④ Stitch width adjustment key  
⑤ Mirror image stitch indicator  
⑥ Utility stitch indicator  
⑦ Stitch category selection key
- ⑧ Sewing speed controller  
⑨ Needle position button  
⑩ Reverse/reinforcement stitch button  
⑪ Start/stop button

- ① LCD (pantalla de cristal líquido)  
① Número de la puntada seleccionada  
② Pie prensatela que se va a utilizar  
③ Longitud de la puntada (mm)  
④ Anchura de la puntada (mm)
- ② Teclas de selección de puntada  
③ Tecla de ajuste de longitud de la puntada  
④ Tecla de ajuste de anchura de la puntada  
⑤ Indicador de puntada imagen en espejo  
⑥ Indicador de puntada con aplicaciones  
⑦ Tecla de selección de la categoría de puntada
- ⑧ Control de velocidad manual  
⑨ Botón de Posición de aguja  
⑩ Botón de Costura en reversa/remate  
⑪ Botón de Inicio/parar

## Selecting a stitch Selección de una puntada

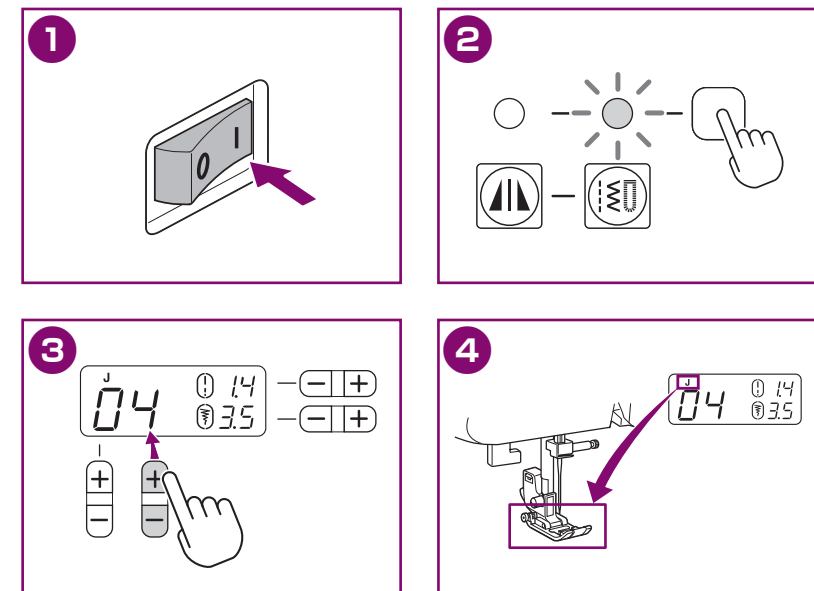

- ① Turn the power on.
- ② Press the stitch category selection key as many times as necessary until the utility stitch indicator is lit.
- ③ Press (stitch selection keys). The number of the selected stitch is displayed.
- ④ Attach the presser foot indicated in the LCD.

## 1 Preparing the bobbin thread Preparación del hilo de la bobina

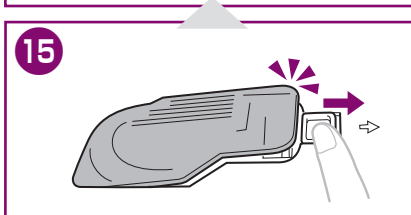
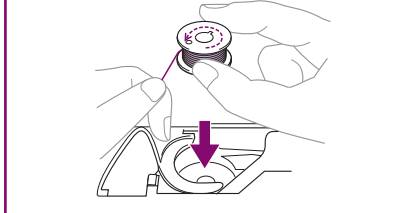
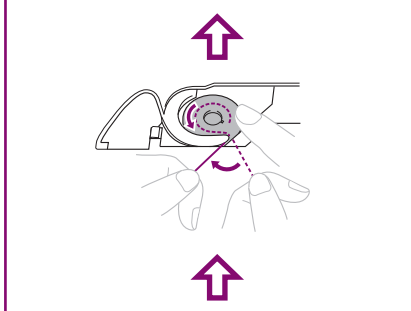
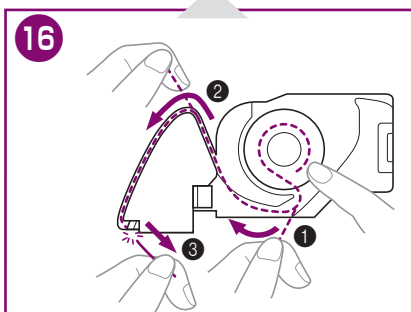
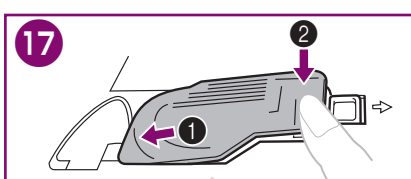
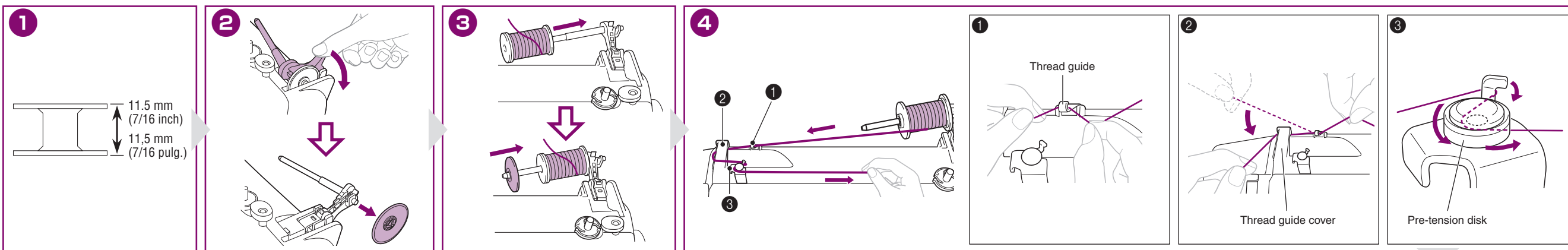

- ① Be sure to use the correct bobbin.
- ② Press down on the spool pin lever. Remove the spool cap.
- ③ Fully insert the spool of thread onto the spool pin. Slide the spool cap onto the spool pin.
- ④ ① Pass the thread under the thread guide.  
② Pass the thread under the thread guide cover.  
③ Pull the thread to the right. Make sure that the thread passes under the pre-tension disk.
- ⑤ Align the notch to the projection. Slide the bobbin to the right.
- ⑥ Wind the end of the thread. Cut the thread.
- ⑦ Slide the sewing speed controller to the right.
- ⑧ Turn the power on.

- ⑨ Press the foot controller or press (start/stop button) to start.
- ⑩ Winding starts. Wait until the bobbin seems full and begins spinning slowly.
- ⑪ Take your foot off the foot controller or press (start/stop button) to stop.
- ⑫ Cut the thread. Slide the bobbin to the left and remove the bobbin from the shaft.
- ⑬ Slide the sewing speed controller to the left.
- ⑭ Turn the power off.
- ⑮ Slide the button and open the cover.
- ⑯ Insert the bobbin. Push the bobbin down. Pull the thread firmly around the tab. Cut the thread with the cutter.
- ⑰ Replace the bobbin cover.

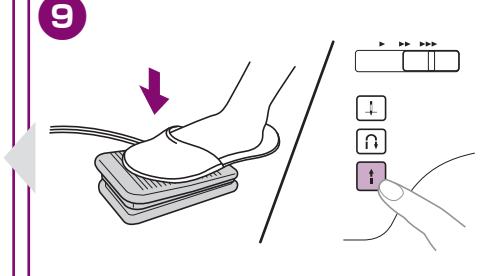
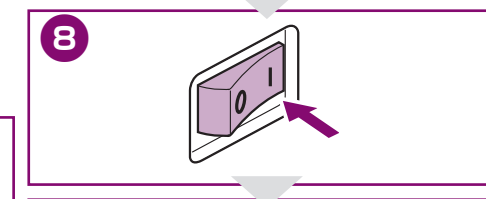
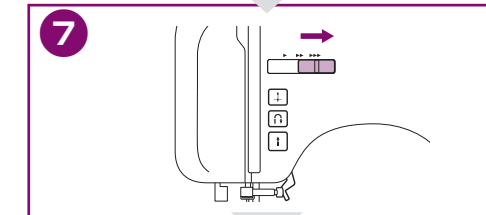
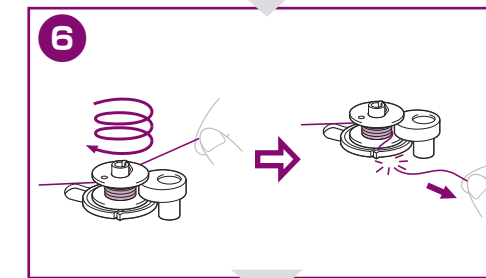
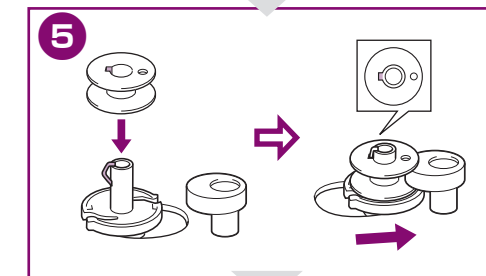
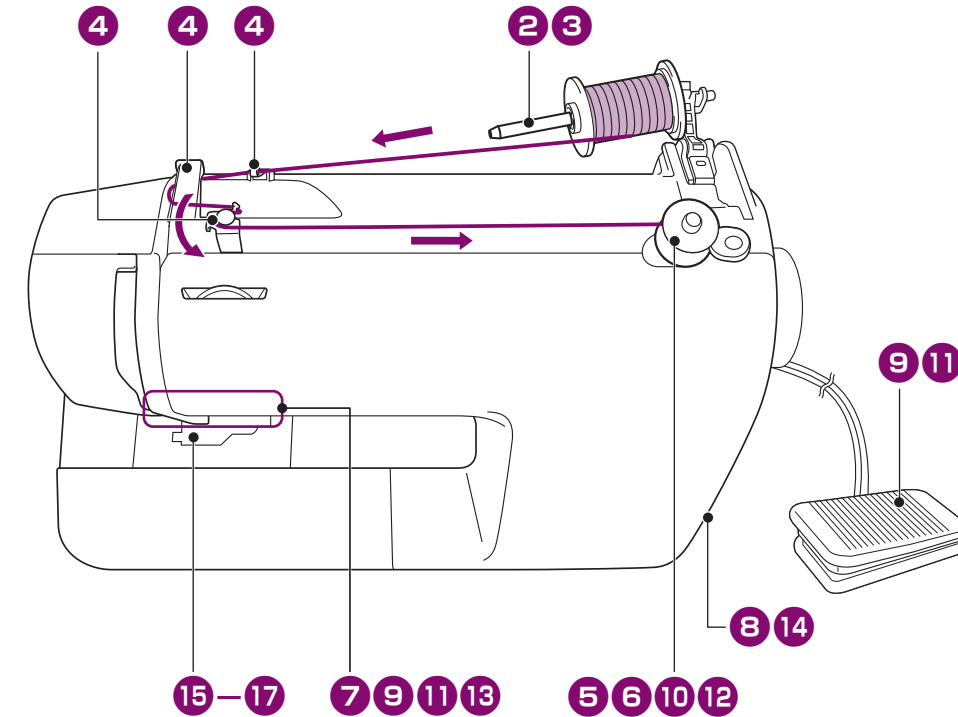

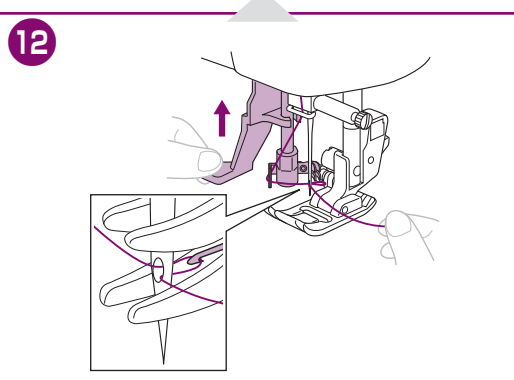
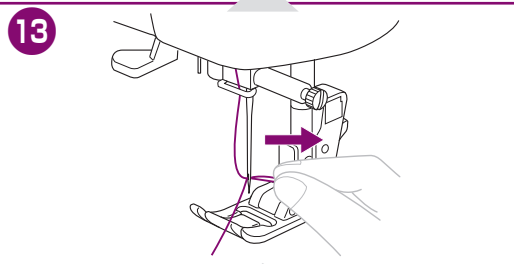
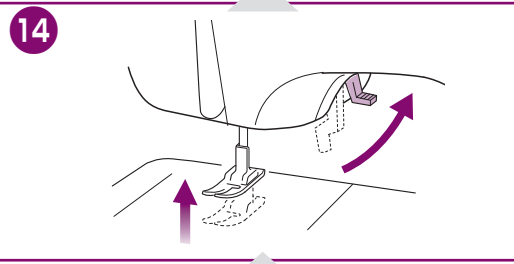
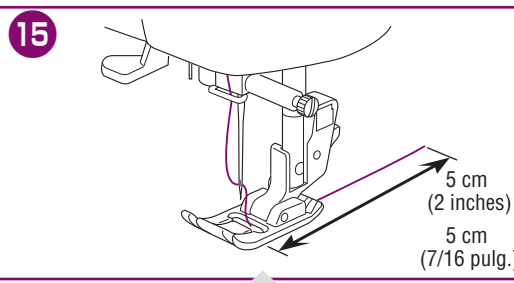
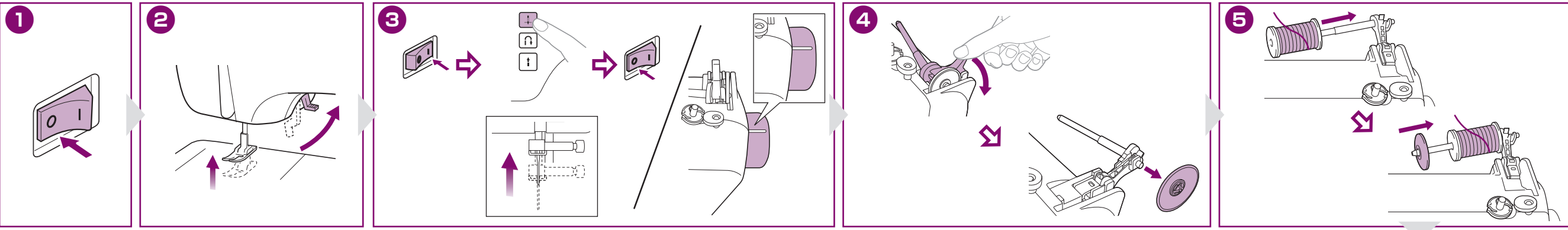

- 1 Turn the power off.
- 2 Raise the presser foot lever.
- 3 Turn the power on. Raise the needle by pressing [ ] once or twice. Turn the power off. Mark on the wheel points up.
- 4 Press down on the spool pin lever. Remove the spool cap.
- 5 Fully insert the spool of thread onto the spool pin. Slide the spool cap onto the spool pin.
- 6 1 Pass the thread under the thread guide.  
2 Pass the thread under the thread guide cover.
- 7 Guide the thread from right to left.
- 8 Put the thread behind the needle bar thread guide above the needle, holding the thread with your left hand.
- 9 Lower the presser foot lever.
- 10 While lowering the needle threader lever, hook the thread onto the guide.
- 11 Fully lower the needle threader lever.
- 12 While lightly holding the thread, release the needle threader lever.
- 13 Pull the loop of the thread.
- 14 Raise the presser foot lever.
- 15 Pull out about 5 cm (2 inches) of thread.

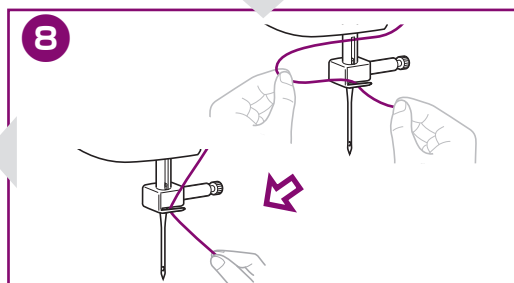
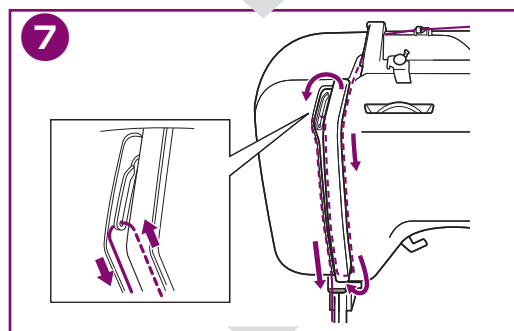
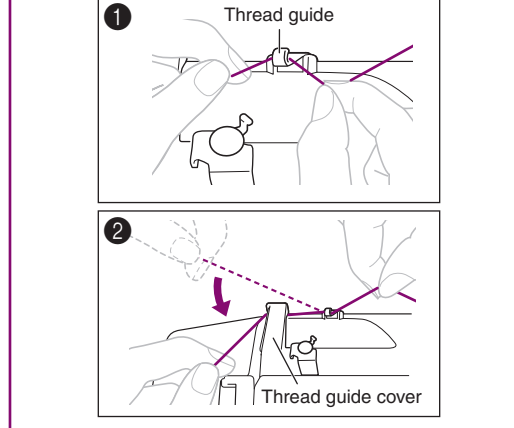
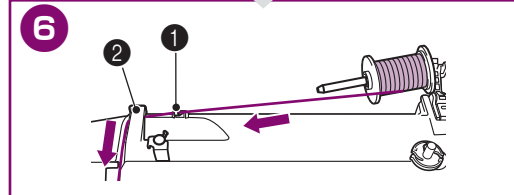
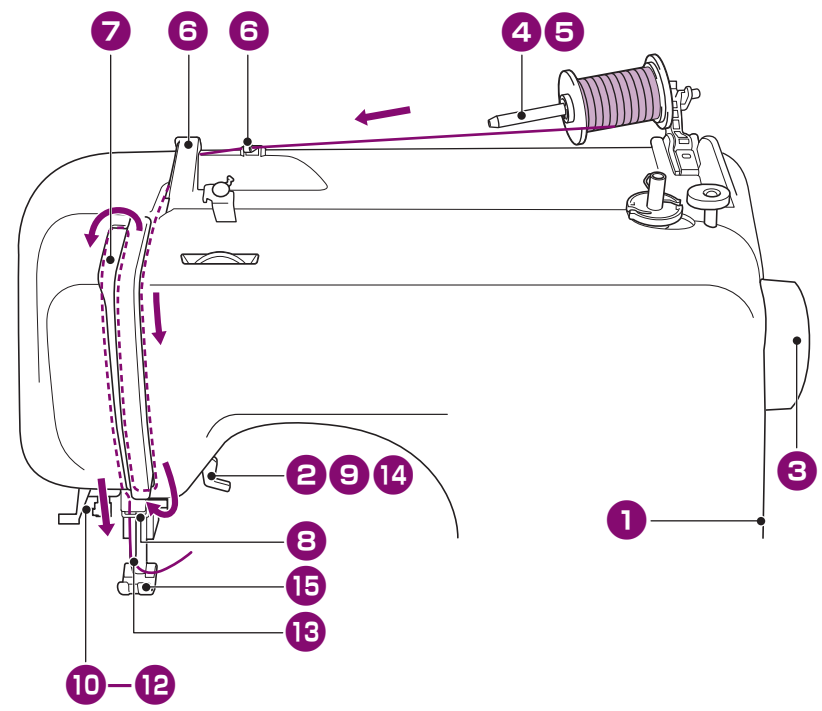

Be sure to first read the "IMPORTANT SAFETY INSTRUCTIONS" in the Operation Manual. Refer to the Operation Manual for detailed instruction.  
Lea primero las "INSTRUCCIONES DE SEGURIDAD IMPORTANTES" del manual de instrucciones. Consulte el manual de instrucciones para obtener información detallada.

List of stitches

Lista de tipos de puntadas

00	01	02	03	04	05	06	07	08	09	10	11
12	13	14	15	16	17	18	19	20	21	22	23
24	25	26	27	28	29	30	31	32	33	34	35
36	37	38	39	40	41	42	43	44	45	46	47
48	49	50	51	52	53	54	55	56	57	58	59
60	61	62	63	64	65	66	67	68	69	70	71
72	73	74	75	76	77	78	79	80	81	82	83
84	85	86	87	88	89	90	91	92	93	94	95
96	97	98	99								

Useful Features

Funciones útiles

- Quick-set bobbin
- Needle threader
- Fast bobbin winding system
- Refer to the operation manual for detailed instruction.
- Bobina rápida
- Enhebrador de aguja
- Sistema de devanado rápido de bobina
- Consulte el manual de instrucciones para obtener información detallada.