

# FD6-B941, B942

パーツブック  
PARTS BOOK  
TEILEKATALOG  
LIVRE DES PIECES  
LIBRO DE REFERENCIA DE PIEZAS

送り出し腕型 4 本針偏平縫ミシン

FOUR NEEDLE FEED OFF THE ARM FLAT SEAMER

VIERNADEL ARMABWÄRTSFLACHSAUMMASCHINE

MACHINE 4 AIGUILLES - POINT CHAINETTE BRAS DEPORTE

CUATRO AGUJAS BRAZO LIBRE BASE PLANA

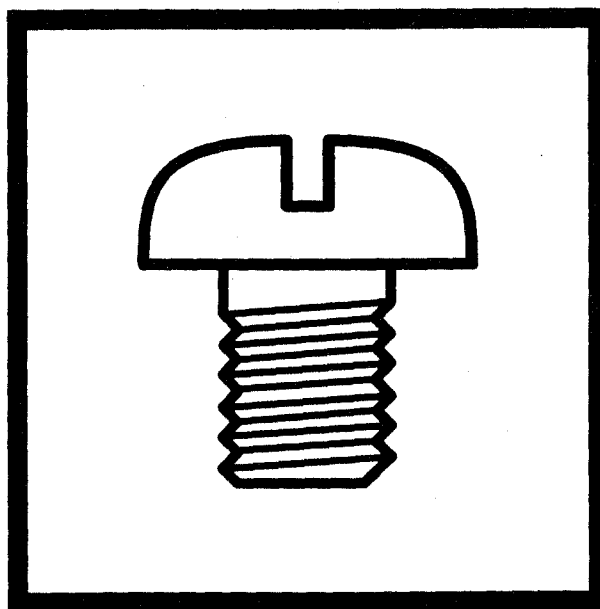

brother®

## Notes for using this parts book

1. This book is applicable to sewing machines which have the same plate number as shown on the cover of this book (or correction sheet).
2. This book was prepared based on information available in July 1998.
3. Parts are subject to changes in design without prior notice.
4. Parts supplied as complete assemblies are circled by a dotted line [-----].
5. If the symbol ※ is found in the "Parts No." column, refer to the different parts list on page 45.

## CONTENTS

A. Machine body .....	1
B. Upper shaft and needle bar mechanism .....	7
C. Presser foot mechanism .....	11
D. Feed mechanism .....	17
E. Spreader mechanism·Knife mechanism .....	21
F. Looper mechanism .....	23
G. Lubrication .....	27
H. Thread tension .....	29
Z. Accessories .....	31
a. Power table .....	39
Gauge parts List .....	45
INDEX .....	46

## Hinweise zur Verwendung dieser Teileliste

1. Dieses Buch bezieht sich auf die Nähmaschinen mit derselben Kennungsnummer wie auf diesem Buchumschlag (oder auf dem Korrekturblatt).
2. Dieses Buch basiert auf den Informationen vom Juli 1998.
3. Modelländerungen sind vorbehalten.
4. Die Teile, die als kompletter Satz geliefert werden, sind mit einer [-----] gestrichelten Linie umrandet.
5. Dieses Zeichen ※ in der Spalte "Parts No. (Teil-nummer)" verweist auf die Gesonderte Stückliste auf Seite 45.

## INHALTSVERZEICHNIS

A. Maschinengehäuse .....	1
B. Obere Welle und Nadelstangenvorrichtung .....	7
C. Stoffdrückerfuß .....	11
D. Transportvorrichtung .....	17
E. Spreizvorrichtung·Messer .....	21
F. Greifer .....	23
G. Schmierung .....	27
H. Faderspannung .....	29
Z. Zubehör .....	31
a. Motorgestell .....	39
Lehrenliste .....	45
VERZEICHNIS .....	46

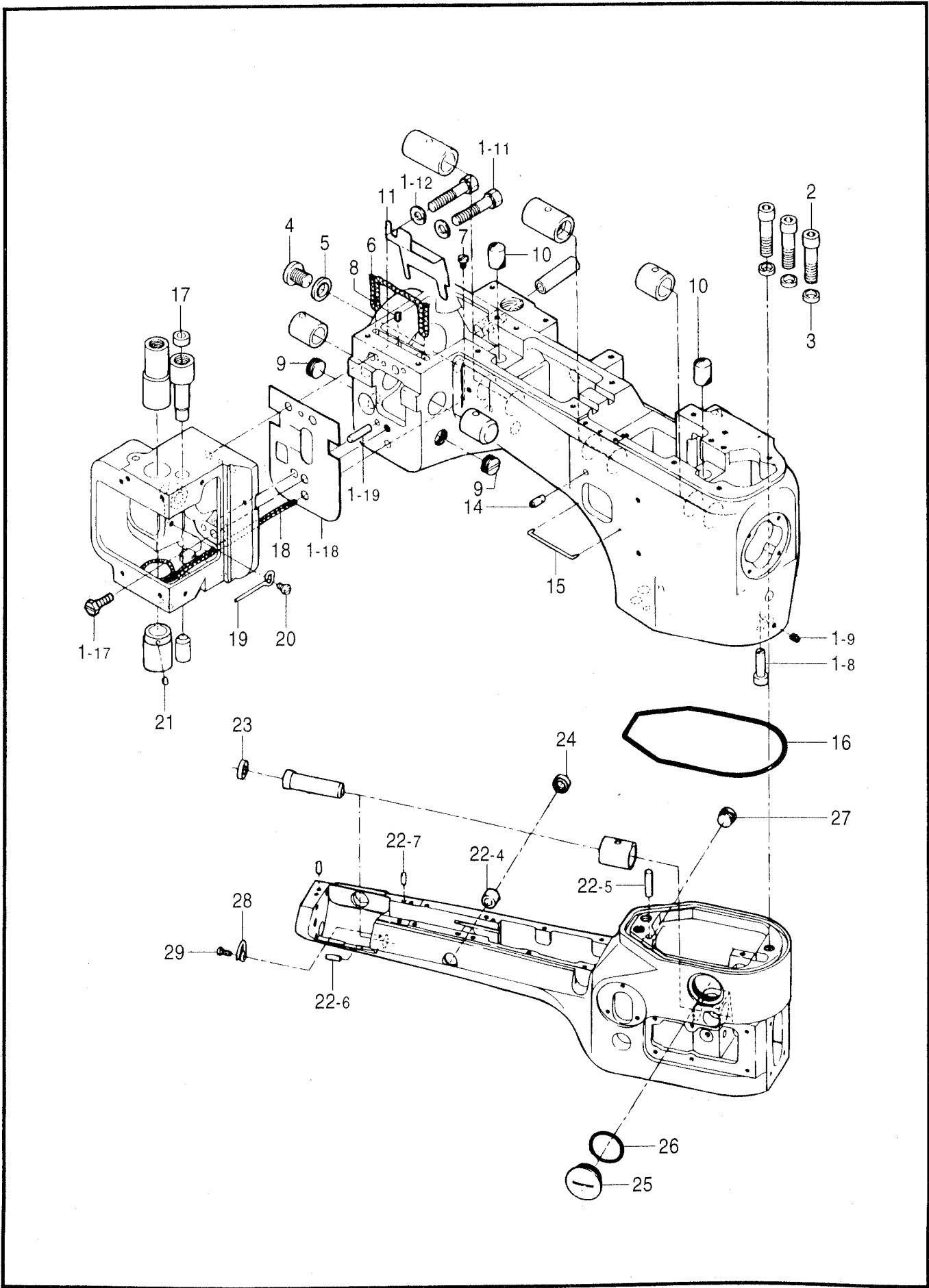

1  
1  
1  
1  
1  
1  
1  
2  
3  
4  
5  
6  
7  
8  
9  
10  
11  
14  
15  
16  
17  
18  
19  
20  
21  
22  
22  
22  
22  
23  
24  
25  
26  
27  
28  
29

A. 主体関係 / Machine body / Maschinengehäuse / Corps de la machine / Cuerpo de la máquina

REF.NO.	CODE	Q'TY	ヒンメイ	NAME OF PARTS	RM
1-8	SP2016001	1	230028エキセンピン	PIN	
1-9	SP0360001	1	005461トメネジ4.37	SCREW	
1-11	SP0363001	2	005555ボルト6.50	BOLT	
1-12	SP2019001	2	202045バネザガネ	SPRING WASHER	
1-17	SP0364001	1	005616ボルト6.50	BOLT	
1-18	SP2026000	1	230008スパーサ	SPACER	
1-19	SP2027001	1	206215ヘイコウピン	PIN	
2	SP0358001	3	005557アナホルト7.94	BOLT	
3	SP2002001	3	230030ザガネ	WASHER	
4	SP0275001	1	005138Bヒラネシ9.53	SCREW	
5	SP1462001	1	202287Aザガネ	WASHER	
6	SP2010000	1	202178クミヒモ	OIL WICK	
7	SP0361001	1	005147ヒラネジ4.37	SCREW	
8	SP2011000	1	202047キユウユフエルト	OIL FELT	
9	SP0362001	2	005556トメネジM14	SCREW	
10	SP2012000	2	230021キユウユフエルト	OIL FELT	
11	SP2013001	1	230020オイルフェンス	OIL GUARD	
14	SP2014001	1	234515イトミチパイプ	THREAD GUIDE	
15	SP2015001	1	234514イトウケ	THREAD GUIDE	
16	SP2017000	1	230042オーリング	O RING	
17	SP2024000	1	230007キユウユフエルト	OIL FELT	
18	SP1450000	1	202174クミヒモ	OIL WICK	
19	SP2028001	1	230009モドシバネ	SPRING	
20	SP0365001	1	005113ヒラネジ4.37	SCREW	
21	SP2040000	1	202081フェルト	FELT	
22-4	SP2034001	1	230027ブツシュ	BUSHING	
22-5	SP2027001	1	206215ヘイコウピン	PIN	
22-6	SP2037001	1	202405ヘイコウピン	PIN	
22-7	SP2038001	2	230031ヘイコウピン	PIN	
23	SP2033000	1	233036オイルシール	OIL SEAL	
24	SP2033000	1	233036オイルシール	OIL SEAL	
25	SP2035001	1	230078フタネジ	SCREW	
26	SP2036000	1	230077ガスケット	GASKET	
27	SP0366001	1	005242ヒラネジ9.53	SCREW	
28	SP2039001	1	234516イトミチ	THREAD GUIDE	
29	SP0367001	1	001326トメネジ3.57	SCREW	

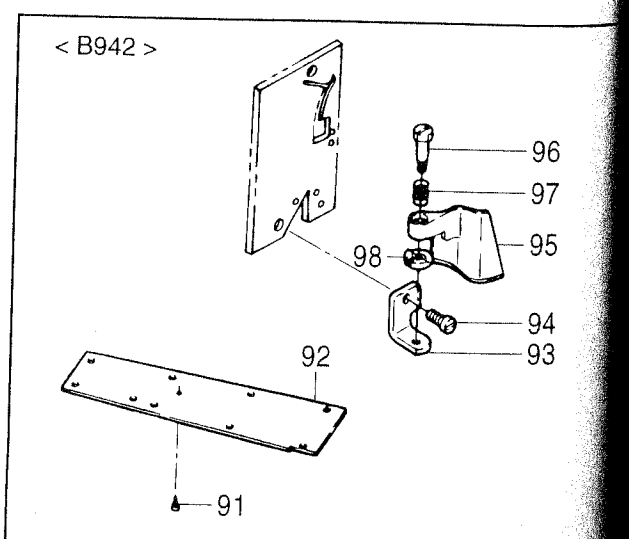
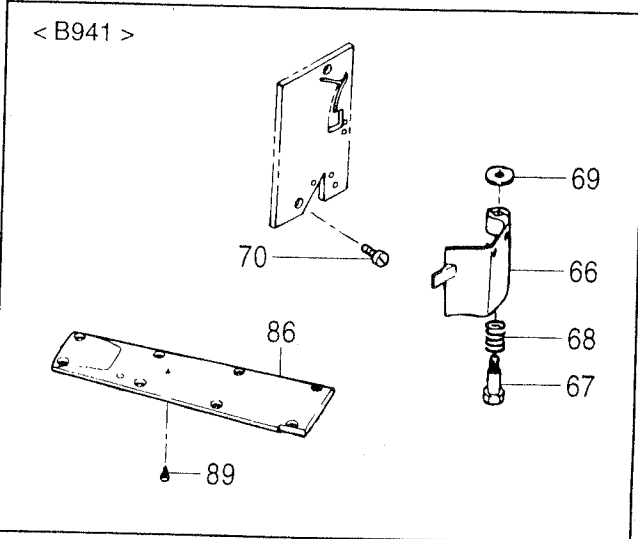
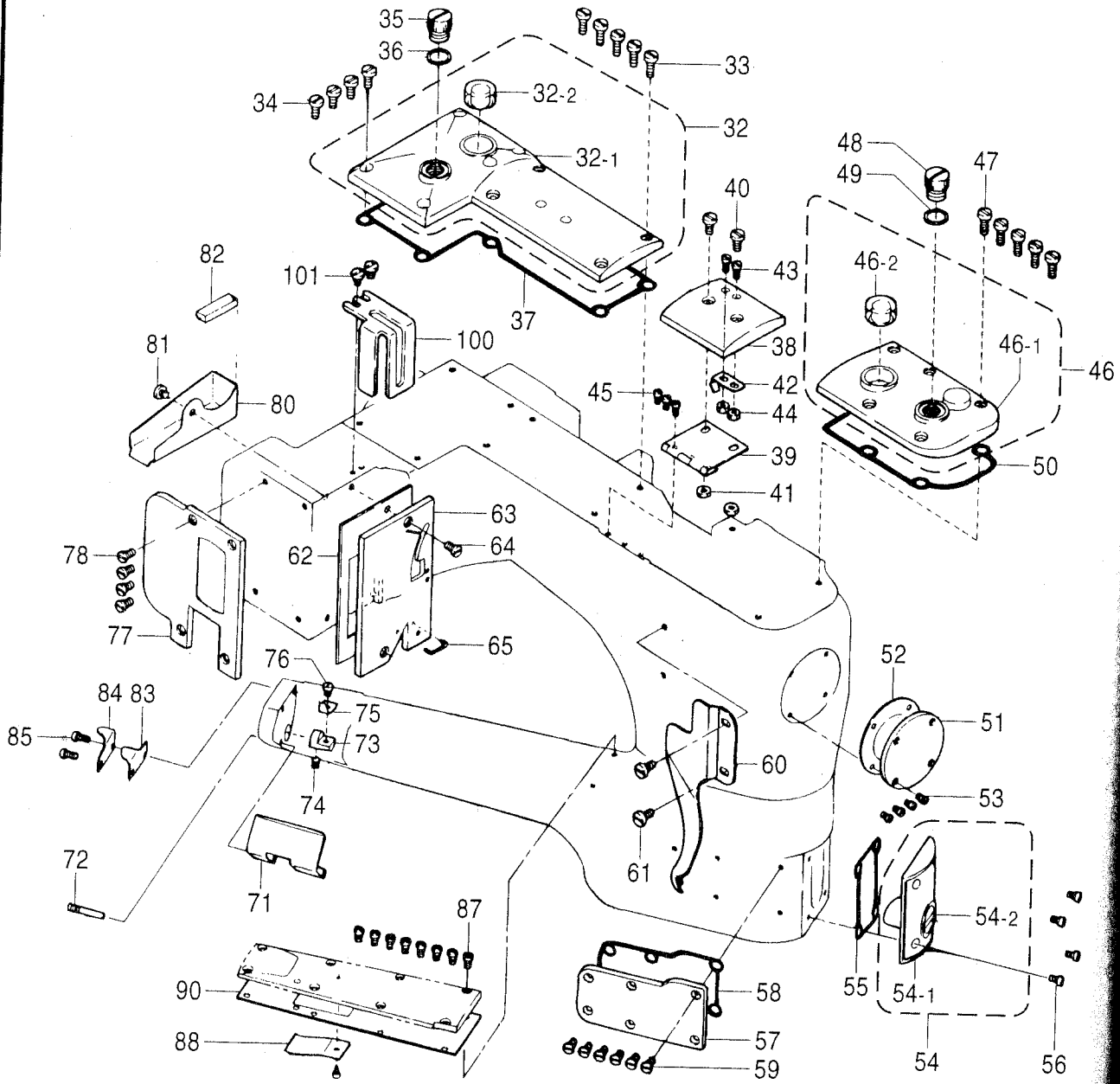

A. 主体関係 / Machine body / Maschinengehäuse / Corps de la machine / Cuerpo de la máquina

REF.NO.	CODE	Q'TY	ヒンメイ	NAME OF PARTS	RM
32	SP2041001	1	230543-9QウワカバA	TOP COVER ASSY	
32-1	SP2042001	1	230544-QDウワカバB	TOP COVER	
32-2	SP2043000	1	230503オイルマド	OIL SIGHT WINDOW	
33	SP0368001	5	005118ヒラネジ4.37	SCREW	
34	SP0369001	4	005116ヒラネジ4.76	SCREW	
35	SP0370001	1	005591ヒラネシ11.11	SCREW	
36	SP2044000	1	202240ガスケット	GASKET	
37	SP2045000	1	230545カバBパツキン	PACKING	
38	SP2046001	1	230546-QDウワカバM	TOP COVER	
39	SP2047001	1	230511ヒンジクミ	HINGE COMPLETE	
40	SP0355001	2	005117ヒラネジ4.37	SCREW	
41	SP0289001	2	003044ナツト4.37	NUT	
42	SP2048001	1	230510イタバネ	FLAT SPRING	
43	SP0371001	2	005142ヒラネジ3.57	SCREW	
44	SP0319001	2	003091ナツト3.57	NUT	
45	SP0372001	3	001998-2ネジ3.57	SCREW	
46	SP2049001	1	230547-9QウワカバA	TOP COVER	
46-1	SP2050001	1	230548-QDウワカバF	TOP COVER	
46-2	SP2043000	1	230503オイルマド	OIL SIGHT WINDOW	
47	SP0368001	5	005118ヒラネジ4.37	SCREW	
48	SP0370001	1	005591ヒラネシ11.11	SCREW	
49	SP2044000	1	202240ガスケット	GASKET	
50	SP2051000	1	230549カバFパツキン	PACKING	
51	SP2052001	1	230518-QDマエカバー	FRONT COVER	
52	SP2053000	1	230519ガスケット	GASKET	
53	SP0290001	4	005053ヒラネジ3.57	SCREW	
54	SP2054001	1	230550-9QカバFクミ	COVER ASSY	
54-1	SP2055001	1	230551-QDカバーF	COVER	
54-2	SP2056001	1	230553オイルゲージ	OIL GAUGE	
55	SP2057000	1	230552カバFパツキン	PACKING	
56	SP0373001	4	005328ヒラネジ3.57	SCREW	
57	SP2058001	1	230554-QDカバーヨコ	CYLINDER SIDE COVER	
58	SP2059000	1	230555カバーパツキン	PACKING	
59	SP0374001	6	005373サラネジ3.57	SCREW	
60	SP2060001	1	230520シタイトカバー	LOOPER THREAD COVER	
61	SP0355001	2	005117ヒラネジ4.37	SCREW	
62	SP2061000	1	230557ガスケット	GASKET	
63	SP2062001	1	230522-QDカバーF	COVER	
64	SP0375001	1	005091ヒラネジ4.37	SCREW	
65	SP2063001	1	230556イトウケ	THREAD GUIDE	
71	SP2067001	1	230529-QDカバー	COVER	
72	SP0377001	1	005559ピンネシ3.57	SCREW	
73	SP2068001	1	230531ブラケット	BRACKET	
74	SP0360001	1	005461トメネジ4.37	SCREW	
75	SP2069001	1	230530イタバネ	SPRING	
76	SP0297001	1	001206ヒラネジ3.57	SCREW	
77	SP2070001	1	230523-QDカバーL	COVER	
78	SP0375001	4	005091ヒラネジ4.37	SCREW	
80	SP2072001	1	230524アブラウケ	OIL RELEASE PLUG	
81	SP0296001	1	002905ヒラネジ4.37	SCREW	
82	SP2073000	1	230525フェルト	FELT	
83	SP2074001	1	230532チエンカツター	CHAIN CUTTER	
84	SP2075001	1	230533カツターガード	CHAIN CUTTER GUARD	
85	SP0367001	2	001326トメネジ3.57	SCREW	
87	SP0378001	8	005328-HCヒラネジ	SCREW	
88	SP2077001	1	230528イタバネ	SPRING	
90	SP2078000	1	230527ガスケット	GASKET	
100	SP2082001	1	230615イトクリカバー	THREAD TAKEUP COVER	
101	SP0382001	2	001216ヒラネジ3.57	SCREW	

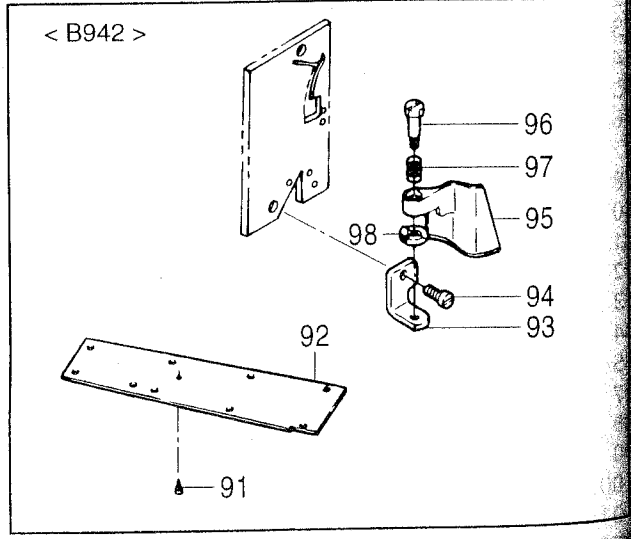
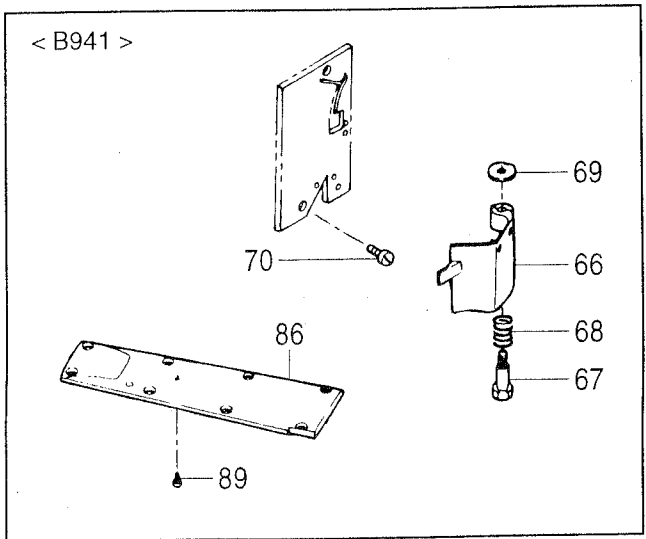
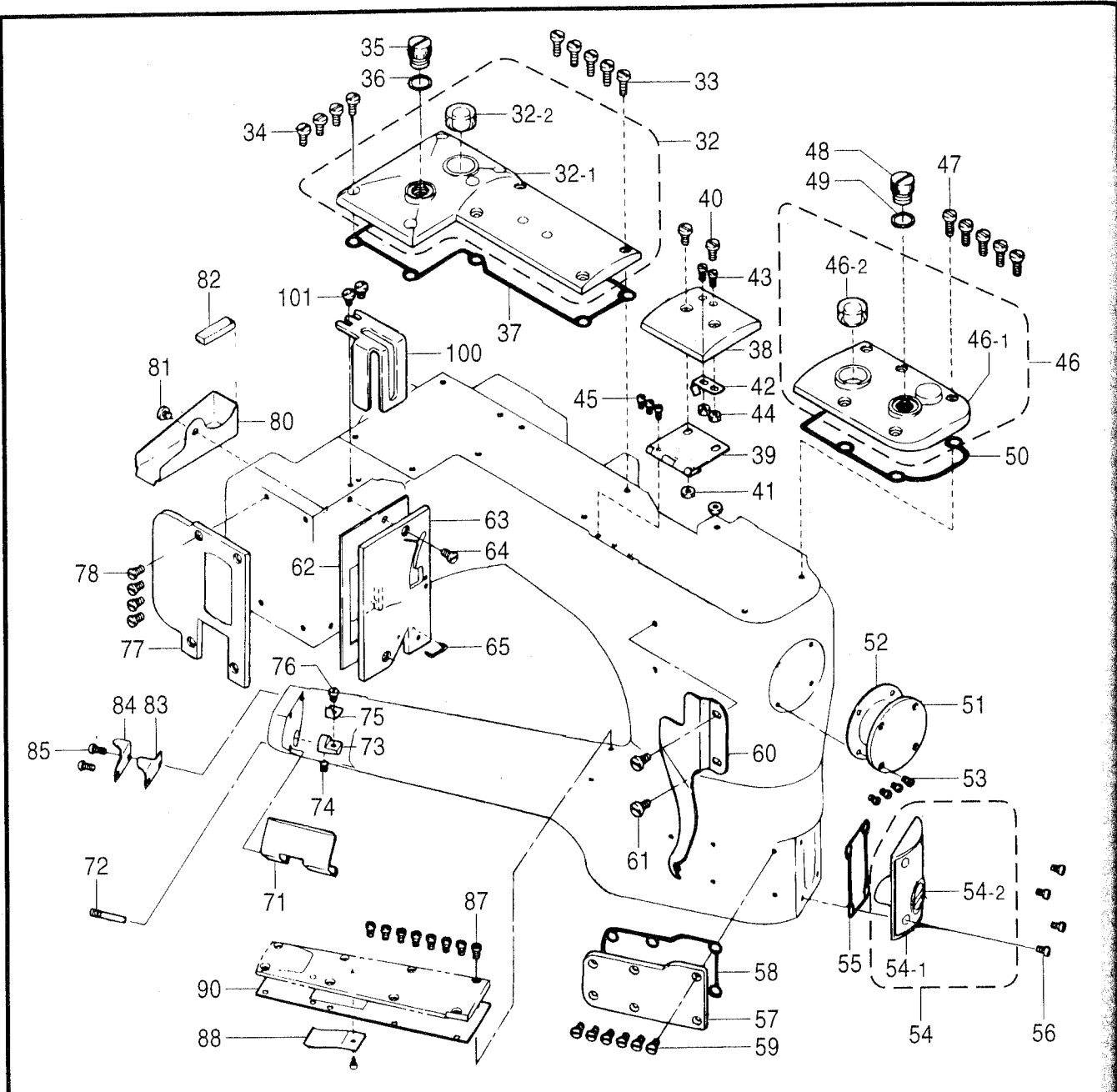

A. 主体関係 / Machine body / Maschinengehäuse / Corps de la machine / Cuerpo de la máquina

REF.NO.	CODE	Q'TY	ヒンメイ	NAME OF PARTS	RM
			<B941>	<B941>	
66	SP2064001	1	230540キリクズアンナイ	WASTE GUIDE	
67	SP0376001	1	005560ダンネシ4.76	SCREW	
68	SP2065001	1	230542アツシユクバネ	SPRING	
69	SP2066001	1	230541ザガネ	WASHER	
70	SP0375001	1	005091ヒラネジ4.37	SCREW	
86	SP2076001	1	230526-QDカバーU	COVER	
89	SP0379001	1	001231ヒラネジ2.38	SCREW	
			<B942>	<B942>	
91	SP0244001	1	005030ヒラネジ2.38	SCREW	
92	SP2079001	1	230558カバーU	COVER	
93	SP2080001	1	230611ブラケット	BRACKET	
94	SP0381001	1	001156ヒラネジ4.37	SCREW	
95	SP2081001	1	230612キリクズアンナイ	WASTE GUIDE	
96	SP0376001	1	005560ダンネシ4.76	SCREW	
97	SP2065001	1	230542アツシユクバネ	SPRING	
98	SP2066001	1	230541ザガネ	WASHER	



B. 上軸・針棒機構 / Upper shaft and needle bar mechanism  
 / Obere Welle und Nadelstangenvorrichtung  
 / Mécanisme de arbre supérieur et barra à aiguille  
 / Mecanismo del eje superior y la barra de aguja

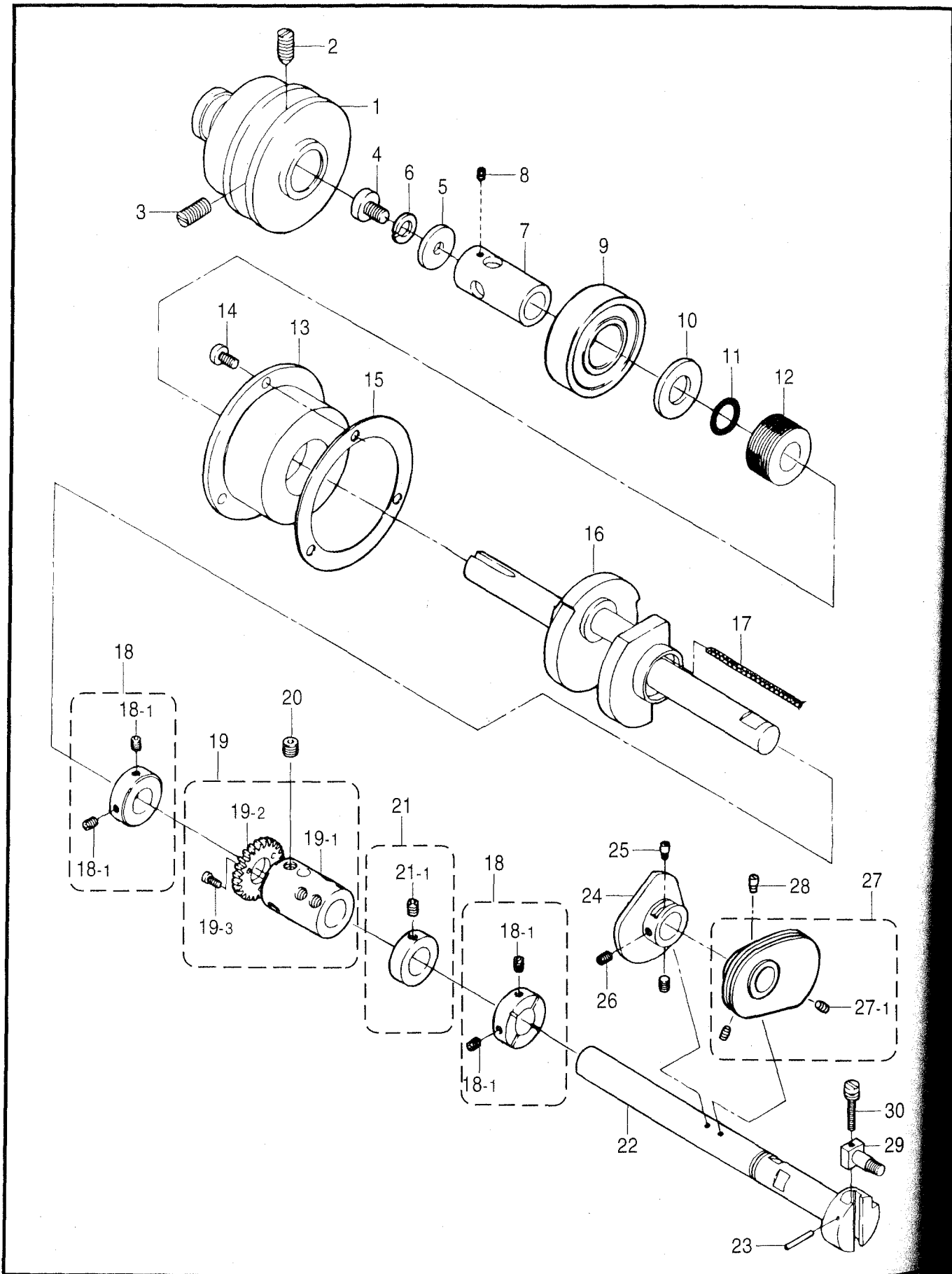

B. 上軸・針棒関係 / Upper shaft and needle bar mechanism / Obere Welle und Nadelstangenvorrichtung / Mécanisme de arbre supérieur et barra à aiguille / Mecanismo del eje superior y la barra de agujaja

REF.NO.	CODE	Q'TY	ヒンメイ	NAME OF PARTS	RM
1	SP2100001	1	231038プーリ	MACHINE PULLEY	
2	SP0383001	1	005398トメネジ7.14	SCREW	
3	SP0384001	1	005399トメネジ7.14	SCREW	
4	SP0385001	1	005357ヒラネジ5.95	SCREW	
5	SP2101001	1	201104ザガネ	WASHER	
6	SP1116001	1	204293バネザガネ	SPRING WASHER	
7	SP2103001	1	231013カラー	COLLAR	
8	SP0386001	1	005267トメネジ3.57	SCREW	
9	SP2104001	1	206082ベアリング	BEARING	
10	SP2105000	1	231012ザガネ	WASHER	
11	SP2106000	1	231011オーリング	O RING	
12	SP2107000	1	231010アブラキリ	OIL SEAL	
13	SP2108000	1	231014ハウジング	HOUSING	
14	SP0355001	3	005117ヒラネジ4.37	SCREW	
15	SP2109000	1	231016ガスケット	GASKET	
16	SP2110001	1	231000クランクジククミ	CRANKSHAFT ASSY	
17	SP1450000	1	202174クミヒモ	OIL WICK	
18	SP2111001	2	231008セツトカラー	COLLAR	
18-1	SP0360001	4	005461トメネジ4.37	SCREW	
19	SP2112001	1	231036-91ツギテクミ	COUPLING ASSY	
19-1	SP2113001	1	231037-DツギテB	COUPLING	
19-2	SP2114001	1	231007ギアル	GEAR (L)	
19-3	SP0387001	3	005336ヒラネジ2.38	SCREW	
20	SP0388001	7	005385トメネジ6.35	SCREW	
21	SP2115001	1	240479ツギテF	COUPLING	
21-1	SP0360001	1	005461トメネジ4.37	SCREW	
22	SP2116001	1	231003ウワジク	ARM SHAFT	
23	SP2117001	1	231018スプリングピン	PIN	
24	SP2118001	1	234535イトクリ	THREAD TAKEUP	
25	SP0389001	1	005105ヒラネジ3.18	SCREW	
26	SP0360001	2	005461トメネジ4.37	SCREW	
27	SP2119001	1	234591-91イトクリ	THREAD TAKEUP	
27-1	SP0390001	2	001457トメネジ4.37	SCREW	
28	SP0389001	1	005105ヒラネジ3.18	SCREW	
29	SP2120001	1	231017ピンツキネジ	SCREW	
30	SP0391001	1	005566ダンネシ3.18	SCREW	

B. 上軸・針棒関係 / Upper shaft and needle bar mechanism  
 / Obere Welle und Nadelstangenvorrichtung  
 / Mécanisme de arbre supérieur et barra à aiguille  
 / Mecanismo del eje superior y la barra de aguja

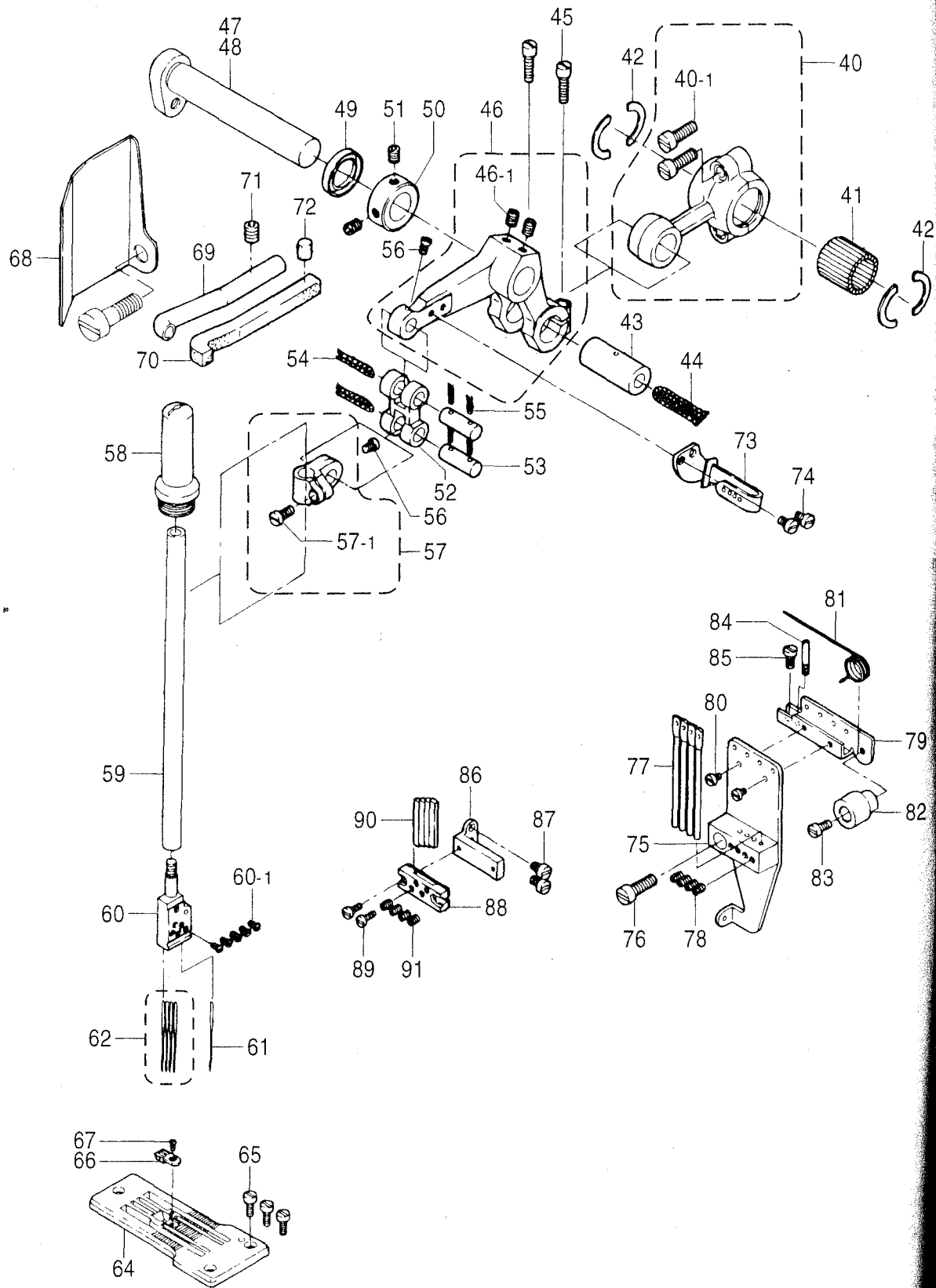

B. 上軸・針棒関係 / Upper shaft and needle bar mechanism / Obere Welle und Nadelstangenvorrichtung / Mécanisme de arbre supérieur et barra à aiguille / Mecanismo del eje superior y la barra de aguaja

REF.NO.	CODE	Q'TY	ヒンメイ	NAME OF PARTS	RM
40	SP2121001	1	231500ロツド	ROD	
40-1	SP0392001	2	002213-1ネジ4.37	SCREW	
41	SP2122001	23	231501ニードルコロ	NEEDLE ROLLER	
42	SP2123001	4	231502ストツバ	STOPPER	
43	SP2124001	1	231504ヘイコウピン	PIN	
44	SP1142000	1	202177クミヒモ	OIL WICK	
45	SP0393001	2	001170ヒラネジ3.57	SCREW	
46	SP2125001	1	231503レバー	LEVER	
46-1	SP0360001	2	005461トメネジ4.37	SCREW	
49	SP2128000	1	202911オイルシール	OIL SEAL	
50	SP2129001	1	231506セツトカラー	COLLAR	
51	SP0360001	2	005461トメネジ4.37	SCREW	
52	SP2130001	1	231507リンク	LINK	
53	SP2131001	2	200654ヘイコウピン	PIN	
54	SP1499000	2	202175クミヒモ	OIL WICK	
55	SP1450000	4	202174クミヒモ	OIL WICK	
56	SP0394001	2	001222ヒラネジ3.18	SCREW	
57	SP2132001	1	231508ハリボウダキ	NEEDLE BAR CLAMP	
57-1	SP0395001	1	001175-2ネジ3.57	SCREW	
58	SP2133001	1	231510キャツブ	CAP	
59	SP2134001	1	231509ハリボウ	NEEDLE BAR	
60	※	1	236601-52ハリドメ	NEEDLE HOLDER	
60-1	SP0396001	5	005562トメネジ2.38	SCREW	
61	SP0041001	1	000660ハリ	NEEDLE	
62	※	4	ハリ	NEEDLE	
64	※	1	ハリイタ	NEEDLE PLATE	
65	SP0397001	3	005588-HCネシ3.57	SCREW	
66	※	1	ハリイタツメ	NEEDLE PLATE FINGER	
67	SP0398001	1	005583サラネジ2.38	SCREW	
68	SP2138001	1	234070アブラヨケイタ	OIL SHIELD	
69	SP2139001	1	234069オイルパイプ	PIPE	
70	SP2141000	1	206850キユウユフエルト	OIL FELT	
71	SP0360001	1	005461トメネジ4.37	SCREW	
72	SP2011000	1	202047キユウユフエルト	OIL FELT	
73	SP2140001	1	234532イトクリ	THREAD TAKEUP ASSY	
74	SP0298001	2	001229ヒラネジ3.18	SCREW	
75	SP2142001	1	234518ブラケツトクミ	BRACKET ASSY	
76	SP0392001	1	002213-1ネジ4.37	SCREW	
77	SP2143001	4	234521イトミチ	THREAD GUIDE	
78	SP0399001	4	005292トメネジ3.18	SCREW	
79	SP2144001	1	234522ブラケツト	BRACKET	
80	SP0379001	2	001231ヒラネジ2.38	SCREW	
81	SP2145001	1	234523ネジリバネ	SPRING	
82	SP2146001	1	234524ホルダ	HOLDER	
83	SP0401001	1	005366ヒラネジ3.18	SCREW	
84	SP0402001	1	005563ピンネシ2.38	SCREW	
85	SP0403001	1	005359ダンネシ3.18	SCREW	
86	SP2147001	1	234530ブラケツト	BRACKET	
87	SP0298001	2	001229ヒラネジ3.18	SCREW	
88	SP2148001	1	234526ブラケツト	BRACKET	
89	SP0387001	2	005336ヒラネジ2.38	SCREW	
90	SP2149001	4	234525イトウケ	THREAD GUIDE	
91	SP0399001	4	005292トメネジ3.18	SCREW	
47	SP2126001	1	<B941> 231505クランクジク	<B941> CRANKSHAFT	
48	SP2127001	1	<B942> 231505Aクランクジク	<B942> CRANK SHAFT	

C . 押工関係 / Presser foot mechanism / Stoffdrückerfuß / Mécanisme de pied presseur / Mecanismo de la prensa tela

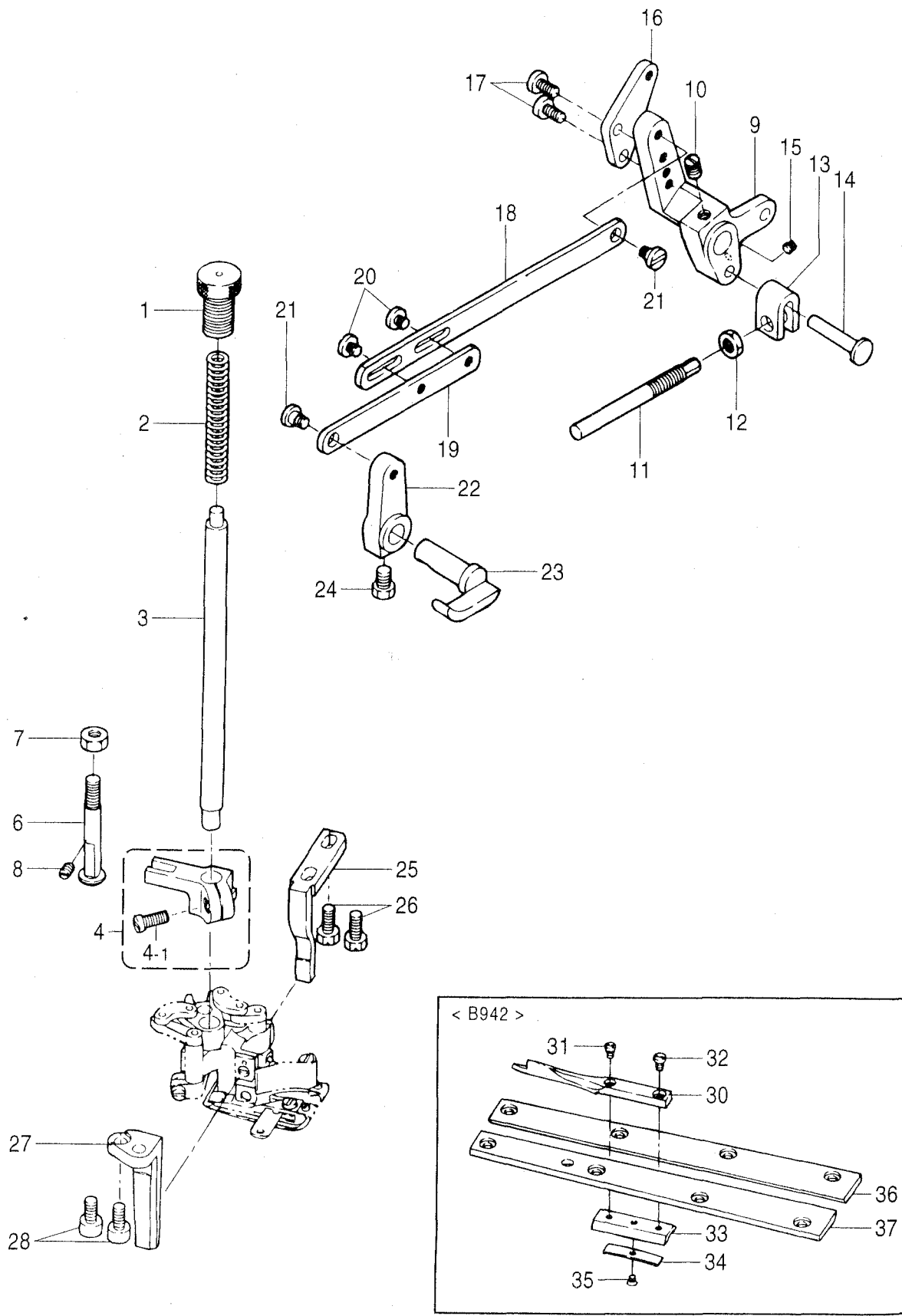

C. 押工関係 / Presser foot mechanism / Stoffdrückerfuß / Mécanisme de pied presseur /  
Mecanismo de la prensa tela

REF.NO.	CODE	Q'TY	ヒンメイ	NAME OF PARTS	RM
1	SP2170001	1	233503チヨウセツネジ	SCREW	
2	SP2171001	1	233504アツシユクバネ	SPRING	
3	SP2172001	1	233500オサエボウ	PRESSER BAR	
4	SP2173001	1	233501アンナイ	GUIDE BLOCK	
4-1	SP0404001	1	005325ヒラネジ4.37	SCREW	
6	SP2174001	1	233502アンナイピン	PIN	
7	SP0405001	1	003144ナツト5.56	NUT	
8	SP0360001	1	005461トメネジ4.37	SCREW	
9	SP2175001	1	233507レバーL	LEVER	
10	SP0406001	1	005185トメネジ5.56	SCREW	
11	SP2176001	1	233508ピンツキネジ	SCREW	
12	SP0407001	1	005020ナツト6.35	NUT	
13	SP2177001	1	233509ラツチ	LATCH	
14	SP2178001	1	233510ダンツキピン	PIN	
15	SP0390001	1	001457トメネジ4.37	SCREW	
16	SP2179001	1	233517レバー	LEVER	
17	SP0355001	2	005117ヒラネジ4.37	SCREW	
18	SP2180001	1	233511リンクL	LINK	
19	SP2181001	1	233512リンクS	LINK	
20	SP0296001	2	002905ヒラネジ4.37	SCREW	
21	SP0408001	2	005494ダンネシ4.37	SCREW	
22	SP2182001	1	233514レバーS	LEVER	
23	SP2183001	1	233513レバー	LEVER	
24	SP0409001	1	005048ボルト5.56	BOLT	
25	SP2184001	1	233516オサエアンナイR	GUIDE/PRESSER FOOT	
26	SP0410001	2	005275ボルト4.76	BOLT	
27	SP2185001	1	233518オサエアンナイL	GUIDE/PRESSER FOOT	
28	SP0411001	2	005579ヒラネジ4.76	SCREW	
30	SP2227001	1	<B942> 236638ヌノアンナイ	<B942> CLOTH GUIDE	
31	SP0419001	1	005578ヒラネジ2.38	SCREW	
32	SP0379001	1	001231ヒラネジ2.38	SCREW	
33	SP2228001	1	236620Aブラケット	BRACKET	
34	SP2229001	1	236621イタバネ	SPRING	
35	SP0496001	1	005304サラネジ2.38	SCREW	
36	SP2230001	1	236622アンナイイタR	GUIDE PLATE	
37	SP2231001	1	236623アンナイイタL	GUIDE PLATE	

< B941 >

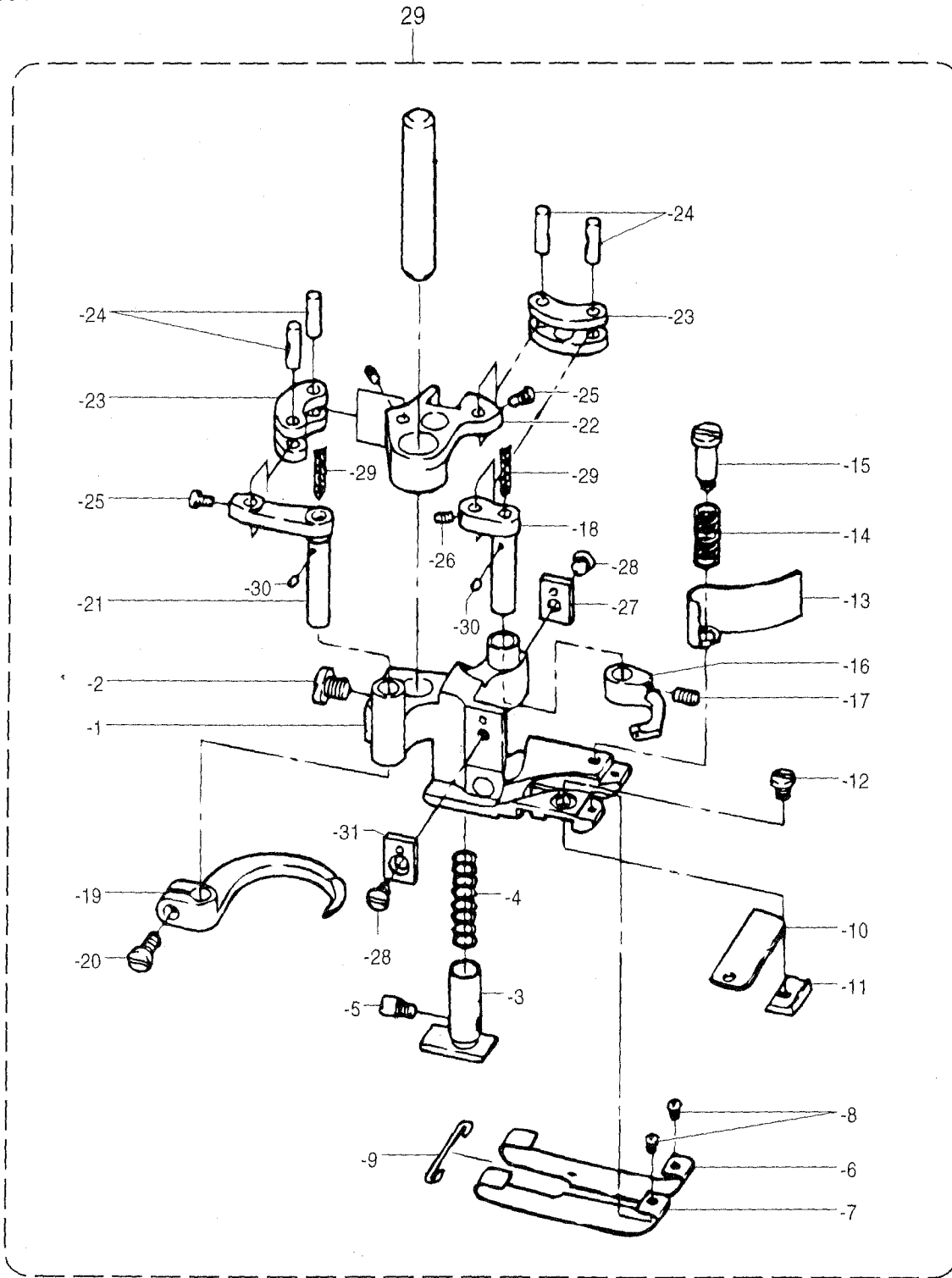

< 左側生地カット用 (オプションパーツ)  
/ For cutting left-side materials ( OPTION PARTS ) >



C. 押工関係 / Presser foot mechanism / Stoffdrückerfuß / Mécanisme de pied presseur /  
Mecanismo de la prensa tela

REF.NO.	CODE	Q'TY	ヒンメイ	NAME OF PARTS	RM
29	※	1	<B941> オサエクミ	<B941> PRESSER FOOT COMPLETE	
29-1	SP2187001	1	236418オサエ	PRESSER FOOT	
29-2	SP0412001	1	005064ヒラネジ4.37	SCREW	
29-3	SP2188001	1	236611Aホジヨオサエ	FABRIC GUARD	
29-4	SP2189001	1	236405アツシユクバネ	SPRING	
29-5	SP0389001	1	005105ヒラネジ3.18	SCREW	
29-6	SP2190001	1	236612DシユーズR	SHOE (R)	
29-7	SP2191001	1	236613DシユーズL	SHOE (L)	
29-8	SP0414001	2	005661ヒラネジ2.38	SCREW	
29-9	SP2192001	1	236406シユーズホルダ	SHOE HOLDER	
29-10	SP2193001	1	236608シタメス	LOWER KNIFE	
29-11	SP2194001	1	236407Aシタメスダキ	LOWER KNIFE CLAMP	
29-12	SP0415001	1	001186ヒラネジ3.18	SCREW	
29-13	SP2195001	1	236413キリクズヨケ	CHIP GUARD	
29-14	SP2196001	1	236416アツシユクバネ	SPRING	
29-15	SP0416001	1	005577ダンネシ3.18	SCREW	
29-17	SP0417001	1	005408トメネジ3.18	SCREW	
29-18	SP2198001	1	236409クランクジク	CRANKSHAFT	
29-19	SP2199001	1	236610フツク	HOOK	
29-20	SP0418001	1	005029ヒラネジ4.37	SCREW	
29-21	SP2200001	1	236410クランクジク	CRANKSHAFT	
29-22	SP2201001	1	236408セグメント	SEGMENT	
29-23	SP2202001	2	236411リンク	LINK	
29-24	SP2203001	4	236412ハイコウピン	PIN	
29-25	SP0419001	2	005578ヒラネジ2.38	SCREW	
29-26	SP0420001	2	005223トメネジ2.38	SCREW	
29-27	SP2204001	1	236420オサエアンナイR	GUIDE/PRESSER FOOT	
29-28	SP0421001	2	005446サラネジ3.18	SCREW	
29-29	SP1450000	2	202174クミヒモ	OIL WICK	
29-30	SP2205000	2	240195フェルト	FELT	
29-31	SP2206001	1	236420AオサエアンナイL	GUIDE/PRESSER FOOT	
29-16	SP2197001	1	<B941-1-52> 236609キャリア	<941-1-52> CARRIER	
29-16	SP2209001	1	<B941-1-60> 236609Aキャリア	<941-1-60> CARRIER	
38	SP2232001	1	<B941オプションパーツ> 236407シタメスダキ	<OPTION PARTS FOR B941> LOWER KNIFE CLAMP	



< B942 >

29

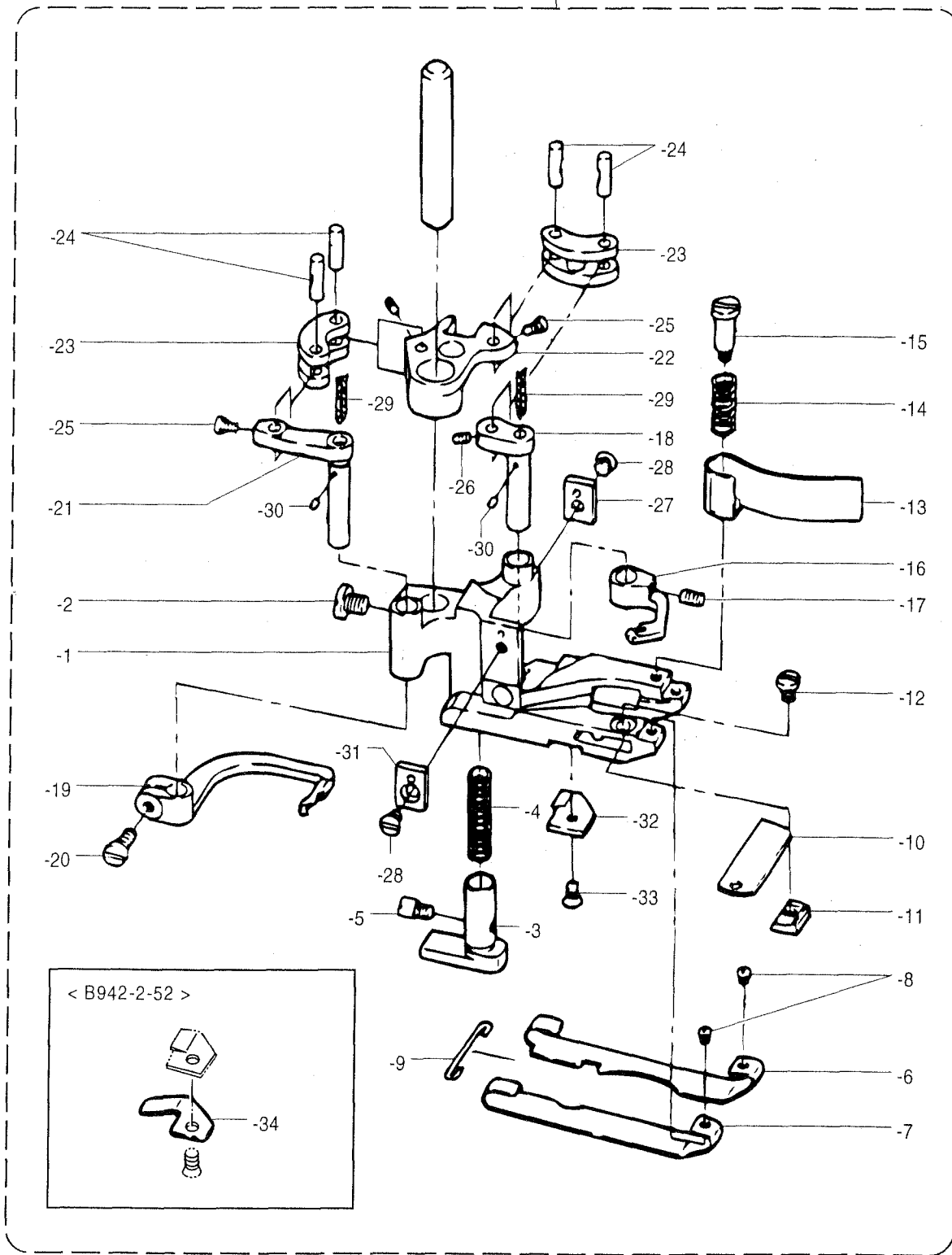

C. 押工関係 / Presser foot mechanism / Stoffdrückerfuß / Mécanisme de pied presseur / Mecanismo de la prensa tela

REF.NO.	CODE	Q'TY	ヒンメイ	NAME OF PARTS	RM
			<B942>	<B942>	
29	※	1	オサエクミ	PRESSER FOOT COMPLETE	
29-2	SP0412001	1	005064ヒラネジ4.37	SCREW	
29-3	SP2214001	1	236614Aホジヨオサエ	SUB PRESSER	
29-4	SP2215001	1	236480アツシユクバネ	SPRING	
29-5	SP0389001	1	005105ヒラネジ3.18	SCREW	
29-8	SP0414001	2	005661ヒラネジ2.38	SCREW	
29-9	SP2192001	1	236406シューズホルダ	SHOE HOLDER	
29-10	SP2193001	1	236608シタメス	LOWER KNIFE	
29-11	SP2218001	1	236482シタメスダキ	LOWER KNIFE CLAMP	
29-12	SP0415001	1	001186ヒラネジ3.18	SCREW	
29-13	SP2219001	1	236481キリクスヨケ	CHIP GUARD	
29-14	SP2196001	1	236416アツシユクバネ	SPRING	
29-15	SP0416001	1	005577ダンネシ3.18	SCREW	
29-16	SP2197001	1	236609キャリア	CARRIER	
29-17	SP0417001	1	005408トメネジ3.18	SCREW	
29-18	SP2198001	1	236409クランクジク	CRANKSHAFT	
29-19	SP2220001	1	236642フツク	HOOK	
29-20	SP0418001	1	005029ヒラネジ4.37	SCREW	
29-21	SP2200001	1	236410クランクジク	CRANKSHAFT	
29-22	SP2201001	1	236408セグメント	SEGMENT	
29-23	SP2202001	2	236411リンク	LINK	
29-24	SP2203001	4	236412ヘイコウピン	PIN	
29-25	SP0419001	2	005578ヒラネジ2.38	SCREW	
29-26	SP0420001	2	005223トメネジ2.38	SCREW	
29-27	SP2204001	1	236420オサエアンナイR	GUIDE/PRESSER FOOT	
29-28	SP0421001	2	005446サラネジ3.18	SCREW	
29-29	SP1450000	2	202174クミヒモ	OIL WICK	
29-30	SP2205000	2	240195フェルト	FELT	
29-31	SP2206001	1	236420AオサエアンナイL	GUIDE/PRESSER FOOT	
29-32	SP2221001	1	236643オサエツメ	PRESSER FOOT FINGER	
29-33	SP0495001	1	005315サラネジ2.38	SCREW	
			<B942-1-52>	<B942-1-52>	
29-1	SP2213001	1	236483-52オサエ	PRESSER FOOT	
29-6	SP2216001	1	236645シューズR	SHOES R	
29-7	SP2217001	1	236644シューズL	SHOES L	
			<B942-2-52>	<B942-2-52>	
29-1	SP2224001	1	236479オサエ	PRESSER FOOT	
29-6	SP2225001	1	236641シューズR	SHOES R	
29-7	SP2226001	1	236640シューズL	SHOES L	
29-34	SP2222001	1	236646イタバネ	SPRING	

b

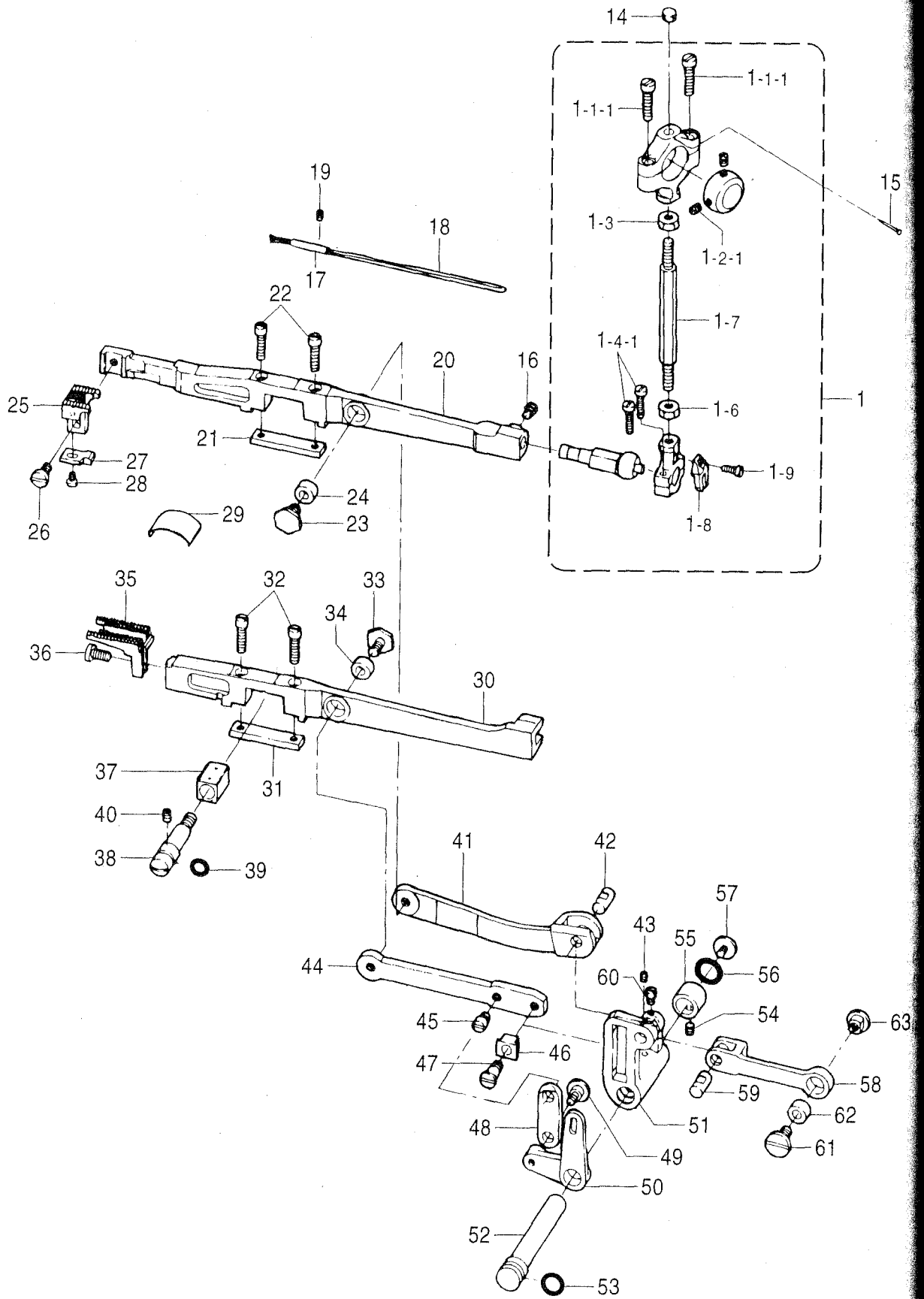

D. 送り関係 / Feed mechanism / Transportvorrichtung / Mécanisme de l'entraînement /  
Mecanismo de la alimentación

REF.NO.	CODE	Q'TY	ヒンメイ	NAME OF PARTS	RM
1	SP2240001	1	233000口ツドクミ	CONNECTION ASSY	
1-1-1	SP0422001	2	005233ヒラネジ4.76	SCREW	
1-2-1	SP0360001	2	005461トメネジ4.37	SCREW	
1-3	SP0423001	1	000089-1ナツト5.35	NUT	
1-4-1	SP0424001	2	001170-1ネジ3.57	SCREW	
1-6	SP0425001	1	000028-1ナツト5.35	NUT	
1-7	SP2245001	1	233003レンケツボウ	CONNECTING BAR	
1-8	SP2246001	1	232513フレドメ	GUIDE	
1-9	SP0426001	1	002918ヒラネジ3.18	SCREW	
14	SP2247000	1	233035フェルト	FELT	
15	SP1452001	1	210766トメピン	PIN	
16	SP0427001	1	005084ボルト4.37	BOLT	
17	SP2248000	1	234066パイプ	PIPE	
18	SP1450000	1	202174クミヒモ	OIL WICK	
19	SP0417001	1	005408トメネジ3.18	SCREW	
20	SP2249001	1	233005シュオクリダイ	MAIN FEED BAR	
21	SP2250001	1	233006ホジヨイタ	AUXILIARY PLATE	
22	SP0428001	2	002928ヒラネジ3.57	SCREW	
23	SP0429001	1	005571ボルト5.56	BOLT	
24	SP2251001	1	233011ブツシュ	BUSHING	
25	※	1	シュオクリバ	FEED DOG	
26	SP0369001	1	005116ヒラネジ4.76	SCREW	
27	SP2282001	1	236605ハリウケB	NEEDLE GUARD	
28	SP0431001	1	002921ヒラネジ3.18	SCREW	
29	SP2252001	1	233034イタバネ	SPRING	
30	SP2253001	1	233007オクリダイ	FEED BAR	
31	SP2250001	1	233006ホジヨイタ	AUXILIARY PLATE	
32	SP0428001	2	002928ヒラネジ3.57	SCREW	
33	SP0429001	1	005571ボルト5.56	BOLT	
34	SP2251001	1	233011ブツシュ	BUSHING	
35	※	1	サドウオクリバ	FEED BAR	
36	SP0369001	1	005116ヒラネジ4.76	SCREW	
37	SP2254000	1	233008カクゴマ	BLOCK/FEED BAR LIFT	
38	SP2255001	1	233009エキセンピン	PIN	
39	SP1290000	1	204185オーリング	O RING	
40	SP0360001	1	005461トメネジ4.37	SCREW	
41	SP2256001	1	233010リンク	LINK	
42	SP2257001	1	233012ヘイコウピン	PIN	
43	SP0432001	1	005220ボルト3.57	BOLT	
44	SP2258001	1	233013リンク	LINK	
45	SP0433001	1	005573ヒラネジ5.56	SCREW	
46	SP2259001	1	233014カクゴマ	BLOCK/FEED BAR LIFT	
47	SP0434001	1	005572ダンネシ5.56	SCREW	
48	SP2260001	1	233015リンク	LINK	
49	SP0435001	1	005574ダンネシ4.37	SCREW	
50	SP2261001	1	233016レバー	LEVER	
51	SP2262001	1	233017クランク	CRANK	
52	SP2263001	1	233037ジク	SHAFT	
53	SP2264000	1	233020オーリング	O RING	
54	SP0360001	2	005461トメネジ4.37	SCREW	
55	SP2265001	1	233019ブツシュ	BUSHING	
56	SP2264000	1	233020オーリング	O RING	
57	SP0361001	1	005147ヒラネジ4.37	SCREW	
58	SP2266001	1	233032リンク	LINK	
59	SP2257001	1	233012ヘイコウピン	PIN	
60	SP0436001	1	005146トメネジ3.57	SCREW	
61	SP0437001	1	005361ヒラネジ5.56	SCREW	
62	SP2251001	1	233011ブツシュ	BUSHING	
63	SP2267001	1	233033Aマルナツト	NUT	

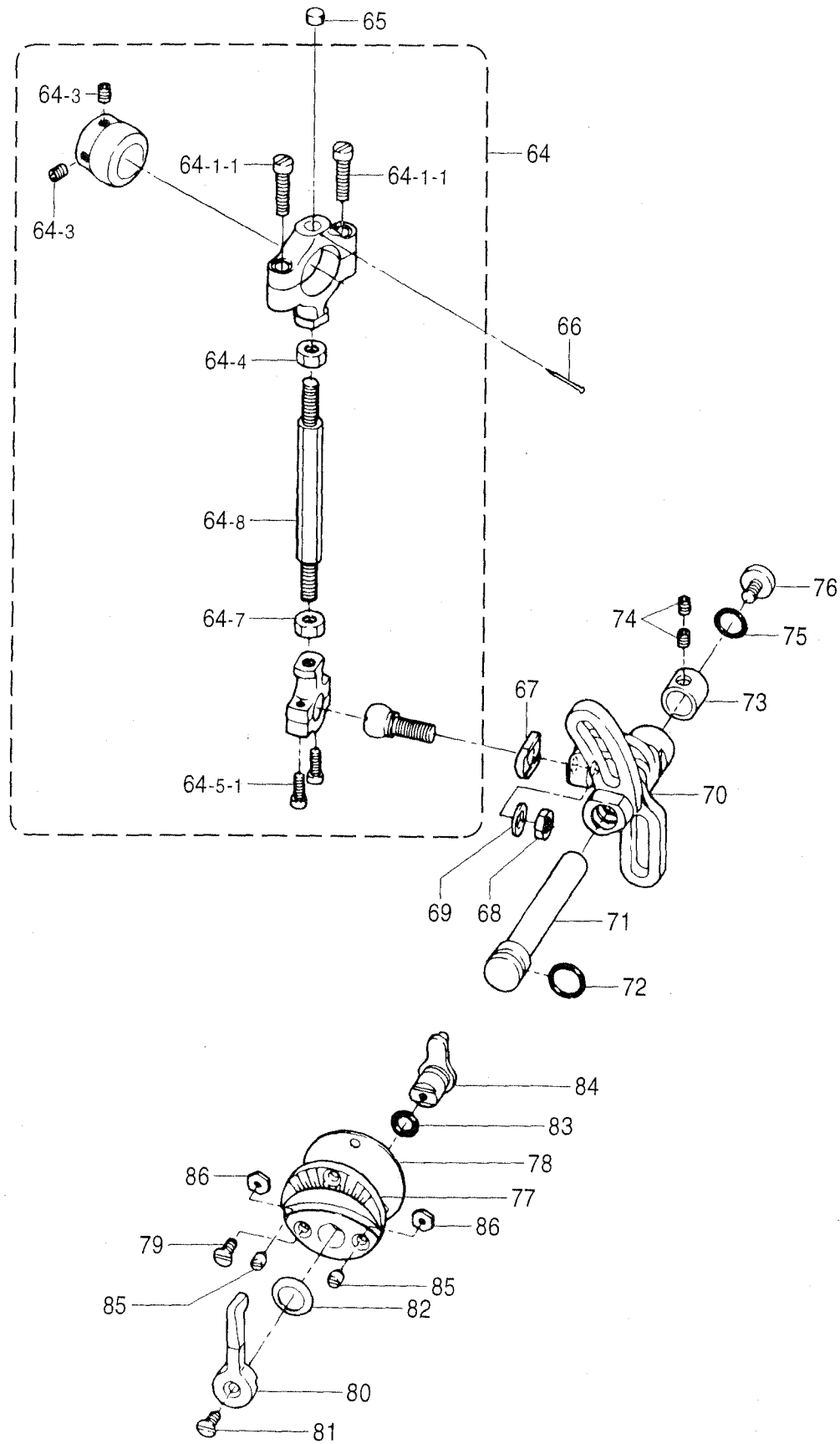

D. 送り関係 / Feed mechanism / Transportvorrichtung / Mécanisme de l'entraînement /  
Mecanismo de la alimentación

REF.NO.	CODE	Q'TY	ヒンメイ	NAME OF PARTS	RM
64	SP2268001	1	233026ロツドクミ	ROD ASSY	
64-1-1	SP0422001	2	005233ヒラネジ4.76	SCREW	
64-3	SP0360001	2	005461トメネジ4.37	SCREW	
64-4	SP0423001	1	000089-1ナツト5.35	NUT	
64-5-1	SP0424001	2	001170-1ネジ3.57	SCREW	
64-7	SP0425001	1	000028-1ナツト5.35	NUT	
64-8	SP2245001	1	233003レンケツボウ	CONNECTING BAR	
65	SP2247000	1	233035フェルト	FELT	
66	SP1452001	1	210766トメピン	PIN	
67	SP2269001	1	233030フレドメ	GUIDE	
68	SP0439001	1	005181ナツト6.35	NUT	
69	SP1874001	1	202433ザガネ	WASHER	
70	SP2273001	1	233031クランク	CRANK	
71	SP2263001	1	233037ジク	SHAFT	
72	SP2264000	1	233020オーリング	O RING	
73	SP2265001	1	233019ブツシュ	BUSHING	
74	SP0360001	2	005461トメネジ4.37	SCREW	
75	SP2264000	1	233020オーリング	O RING	
76	SP0361001	1	005147ヒラネジ4.37	SCREW	
77	SP2275001	1	233021ヒヨウジイタ	INDICATION PLATE	
78	SP2276000	1	233022ガスケット	GASKET	
79	SP0374001	3	005373サラネジ3.57	SCREW	
80	SP2277001	1	233024レバー	LEVER	
81	SP0374001	1	005373サラネジ3.57	SCREW	
82	SP2278001	1	233025バネザガネ	SPRING WASHER	
83	SP1290000	1	204185オーリング	O RING	
84	SP2279001	1	233038レバー	LEVER	
85	SP0440001	2	005575ヒラネジ3.18	SCREW	
86	SP0441001	2	003152ナツト3.18	NUT	

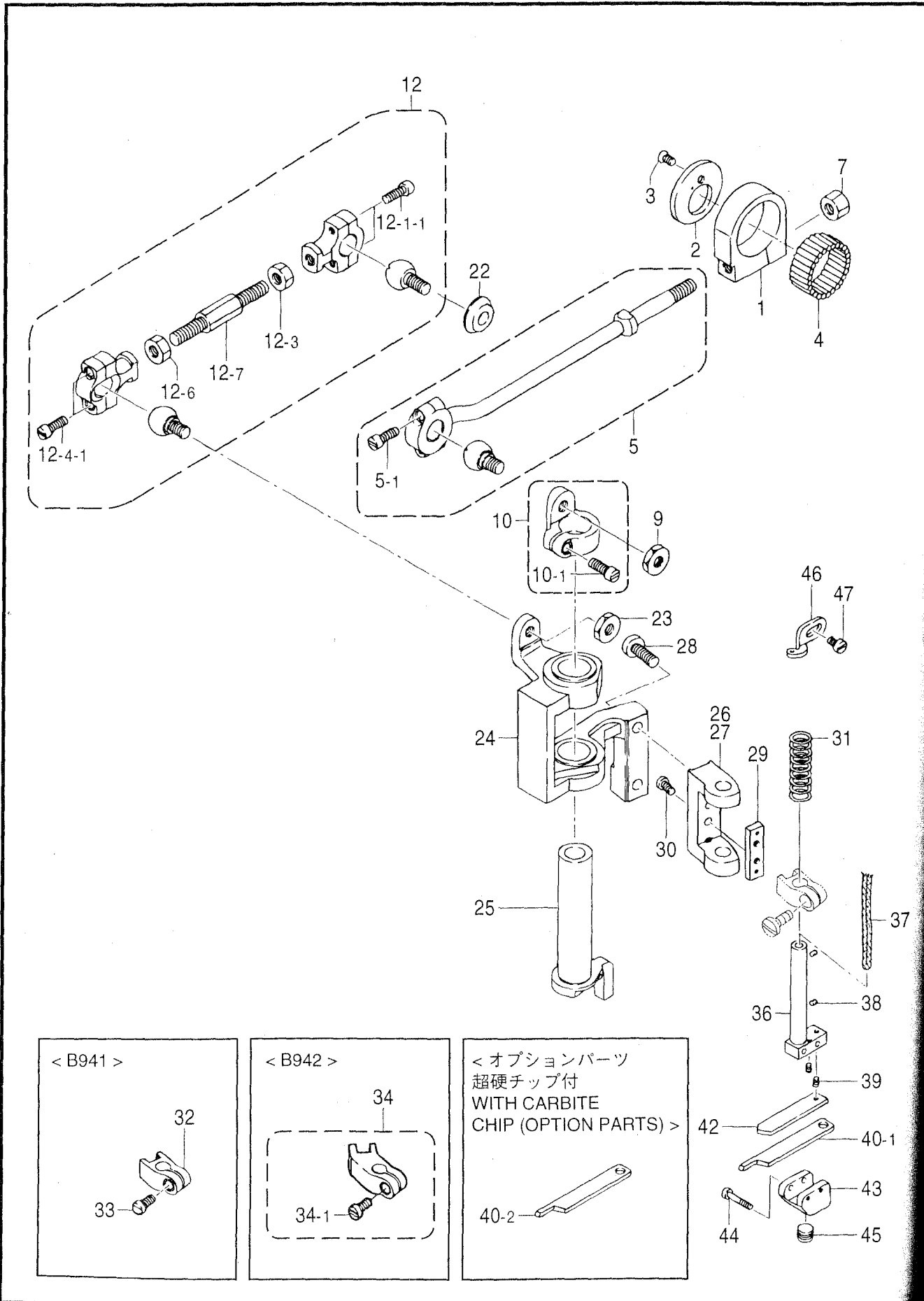

E. 飾り振り上メス関係 / Spreader mechanism·Knife mechanism / Spreizvorrichtung·Messer / Mécanisme de l'étendeur·Mécanisme du couteau / Mecanismo extendedor·Mecanismo del cuchilla

REF.NO.	CODE	Q'TY	ヒンメイ	NAME OF PARTS	RM
1	SP2300001	1	232000ロツド	ROD	
2	SP2301001	1	232001ザガネ	WASHER	
3	SP0442001	1	005437サラネジ3.18	SCREW	
4	SP2302001	27	232002ヘイコウピン	PIN	
5	SP2326001	1	232035-91ロツドクミ	ROD ASSY	
5-1	SP0424001	2	001170-1ネジ3.57	SCREW	
7	SP0443001	1	005455ナツト5.56	NUT	
9	SP0444001	1	003151ナツト6.35	NUT	
10	SP2305001	1	232005レバー	LEVER	
10-1	SP0424001	1	001170-1ネジ3.57	SCREW	
12	SP2306001	1	232007ロツドクミ	ROD ASSY	
12-1-1	SP0424001	2	001170-1ネジ3.57	SCREW	
12-3	SP0423001	1	000089-1ナツト5.35	NUT	
12-4-1	SP0424001	2	001170-1ネジ3.57	SCREW	
12-6	SP0425001	1	000028-1ナツト5.35	NUT	
12-7	SP2310001	1	232010レンケツボウ	ROD	
22	SP2311001	1	232012フレドメ	GUIDE	
23	SP0444001	1	003151ナツト6.35	NUT	
24	SP2312001	1	232023ウワメスダイ	UPPER KNIFE LEVER	
25	SP2313001	1	232006クランクジク	CRANKSHAFT	
28	SP0368001	2	005118ヒラネジ4.37	SCREW	
29	SP2316001	1	232017アンナイイタ	GUIDE PLATE/KNIFE LEVER	
30	SP0446001	2	005012ヒラネジ3.18	SCREW	
31	SP2317001	1	232020アツシユクバネ	SPRING	
36	SP2320001	1	232019クランクジク	CRANKSHAFT	
37	SP1393000	1	202176クミヒモ	OIL WICK	
38	SP1450000	2	202174クミヒモ	OIL WICK	
39	SP0420001	2	005223トメネジ2.38	SCREW	
40-1	SP2321001	1	236606ウワメス	UPPER KNIFE	
42	SP2323001	1	232022ホジヨイタ	AUXILIARY PLATE	
43	SP2324001	1	232021ウワメスダキ	UPPER KNIFE CLAMP	
44	SP0447001	2	005565ヒラネジ2.38	SCREW	
45	SP0448001	1	005312トメネジ6.35	SCREW	
46	SP2325001	1	234531イトミチ	THREAD GUIDE	
47	SP0298001	1	001229ヒラネジ3.18	SCREW	
26	SP2314001	1	<B941> 232025ブラケット	<B941> BRACKET	
32	SP2318001	1	232018アンナイ	GUIDE	
33	SP0371001	1	005142ヒラネジ3.57	SCREW	
27	SP2315001	1	<B942> 232033ブラケット	<B942> BRACKET	
34	SP2319001	1	232034-92アンナイ	GUIDE	
34-1	SP0371001	1	005142ヒラネジ3.57	SCREW	
40-2	SP2322001	1	<オプションパーツ 超硬チップ付> 236607ウワメス	<WITH CARBIDE CHIP(OPTION PARTS)> UPPER KNIFE	



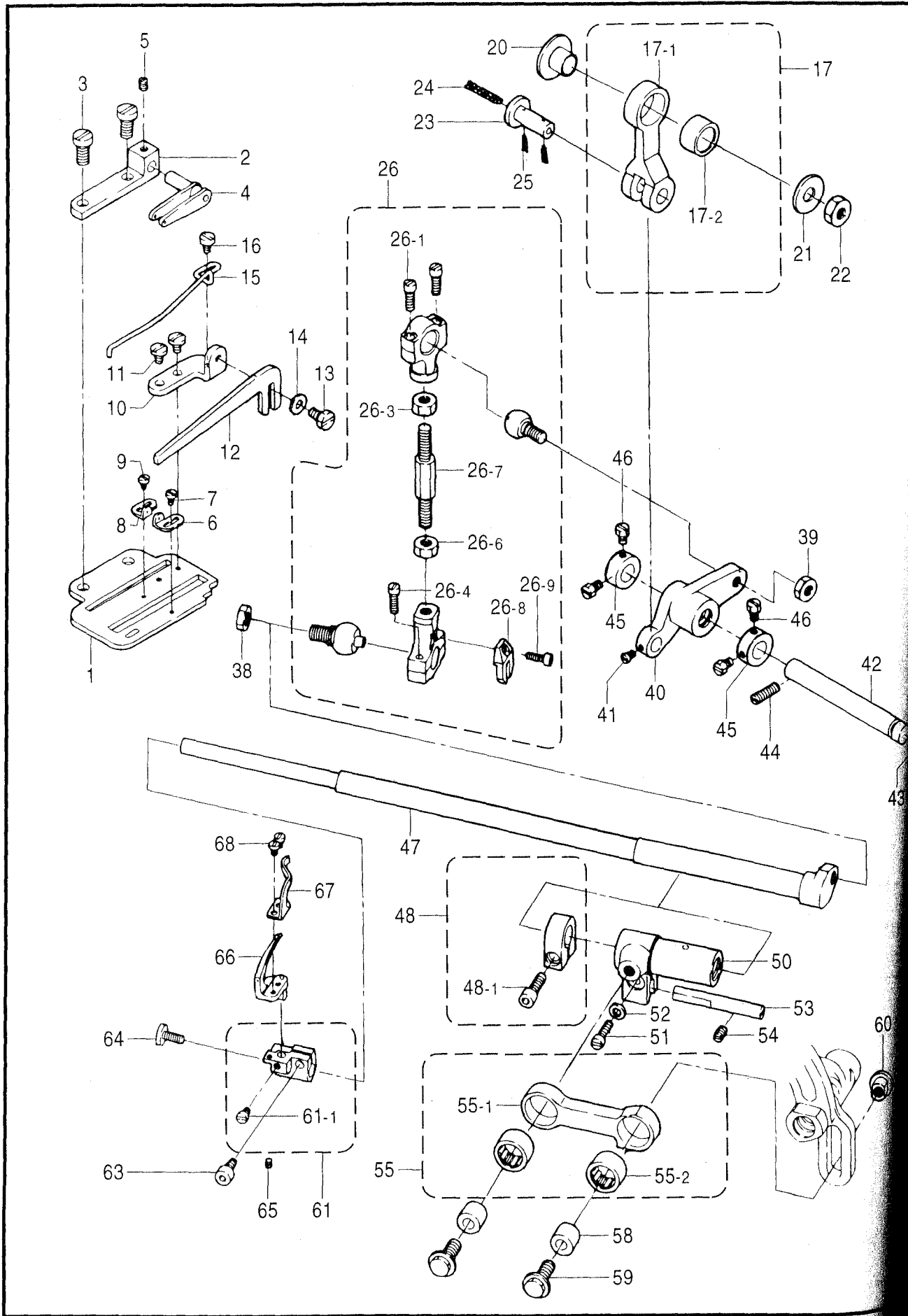

F. ルーパ-関係 / Looper mechanism / Greifer / Mécanisme des griffes / Mecanismo del presilladora

REF.NO.	CODE	Q'TY	ヒンメイ	NAME OF PARTS	RM
1	SP2330001	1	234524Bブラケット	BRACKET	
2	SP2331001	1	234546ブラケット	BRACKET	
3	SP0449001	2	005186ヒラネジ5.56	SCREW	
4	SP2332001	1	234547イトクリアンナイ	GUIDE/THREAD TAKEUP ASSY	
5	SP0436001	1	005146トメネジ3.57	SCREW	
6	SP2333001	1	234544イトミチ	THREAD GUIDE	
7	SP0379001	1	001231ヒラネジ2.38	SCREW	
8	SP2334001	1	234545イトミチ	THREAD GUIDE	
9	SP0379001	1	001231ヒラネジ2.38	SCREW	
10	SP2335001	1	234588ブラケット	BRACKET	
11	SP0450001	2	005600ヒラネジ3.18	SCREW	
12	SP2336001	1	234589イトアンナイ	THREAD GUIDE	
13	SP0451001	1	005364ボルト3.57	BOLT	
14	SP2337001	1	137906ザガネ	WASHER	
15	SP2338001	1	234590イトウケ	THREAD SUPPORT	
16	SP0452001	1	005141ヒラネジ2.38	SCREW	
17	SP2339001	1	232500リンククミ	LINK ASSY	
17-1	SP2340001	1	232501リンク	LINK ASSY	
17-2	SP2341001	1	232502ベアリング	BEARING	
20	SP2342001	1	232503ブツシュ	BUSHING	
21	SP2343001	1	204023ザガネ	WASHER	
22	SP0423001	1	000089-1ナツト5.35	NUT	
23	SP2344001	1	232504ダンツキピン	PIN	
24	SP1499000	1	202175クミヒモ	OIL WICK	
25	SP1450000	2	202174クミヒモ	OIL WICK	
26	SP2345001	1	232509Aロツドクミ	ROD ASSY	
26-1	SP0424001	2	001170-1ネジ3.57	SCREW	
26-3	SP0423001	1	000089-1ナツト5.35	NUT	
26-4	SP0424001	2	001170-1ネジ3.57	SCREW	
26-6	SP0425001	1	000028-1ナツト5.35	NUT	
26-7	SP2310001	1	232010レンケツボウ	ROD	
26-8	SP2246001	1	232513フレドメ	GUIDE	
26-9	SP0426001	1	002918ヒラネジ3.18	SCREW	
38	SP0407001	1	005020ナツト6.35	NUT	
39	SP0407001	1	005020ナツト6.35	NUT	
40	SP2350001	1	232505Aレバ-	LEVER	
41	SP0394001	1	001222ヒラネジ3.18	SCREW	
42	SP2351001	1	232506ジク	SHAFT	
43	SP2352000	1	240165オーリング	O RING	
44	SP0453001	1	001435トメネジ4.37	SCREW	
45	SP2353001	2	232508セツトカラー	COLLAR	
46	SP0432001	4	005220ボルト3.57	BOLT	
47	SP2354001	1	232520ルーバジク	LOOPER SHAFT	
48	SP2355001	1	232521セツトカラー	COLLAR	
48-1	SP0454001	1	005568ヒラネジ4.37	SCREW	
50	SP2356001	1	232517スリーブ	SLEEVE	
51	SP0393001	1	001170ヒラネジ3.57	SCREW	
52	SP2357001	1	232518ハツキザガネ	WASHER	
53	SP2358001	1	232519ヘイコウピン	PIN	
54	SP0455001	1	001458トメネジ4.37	SCREW	
55	SP2359001	1	232514リンククミ	LINK ASSY	
55-1	SP2360001	1	232515リンク	LINK	
55-2	SP2341001	2	232502ベアリング	BEARING	
58	SP2362001	2	232516ブツシュ	BUSHING	
59	SP0456001	2	005567ダンネシ5.56	SCREW	
60	SP2363001	1	233033Bマルナツト	NUT	
61	SP2364001	1	232522-92ルーバタイ	LOOPER HOLDER	
61-1	SP0457001	1	005053Aヒラネシ3.57	SCREW	
63	SP0458001	1	005569ボルト3.57	BOLT	

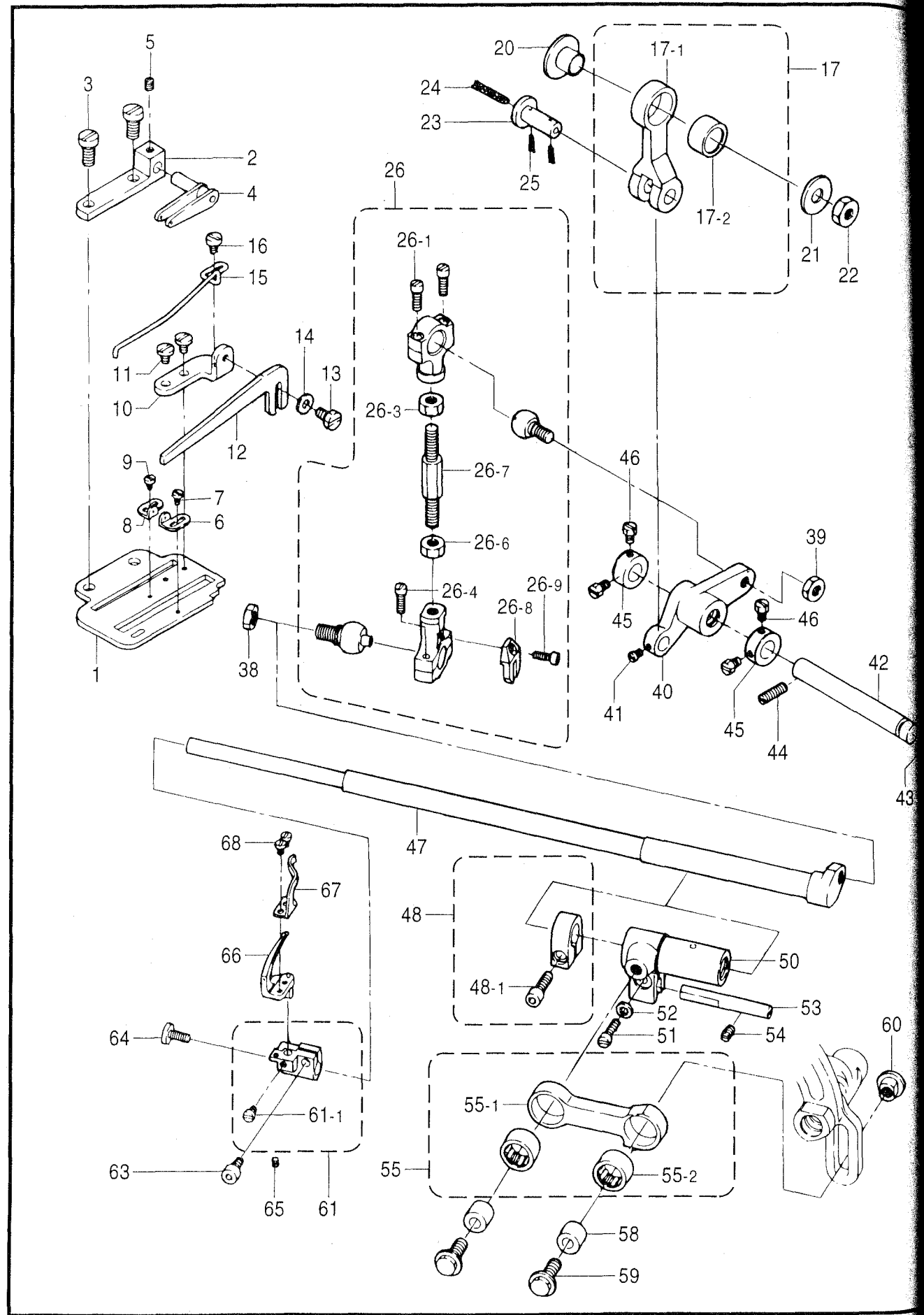

F. ルーパー関係 / Looper mechanism / Greifer / Mécanisme des griffes / Mecanismo del presilladora

REF.NO.	CODE	Q'TY	ヒンメイ	NAME OF PARTS	RM
64	SP0459001	1	005590ヒラネジ3.57	SCREW	
65	SP0420001	1	005223トメネジ2.38	SCREW	
66	SP2365001	1	236500ルーパー	LOOPER	
67	SP2366001	1	236600ルーパーホジヨキ	LOOPER GUARD	
68	SP0379001	2	001231ヒラネジ2.38	SCREW	

t

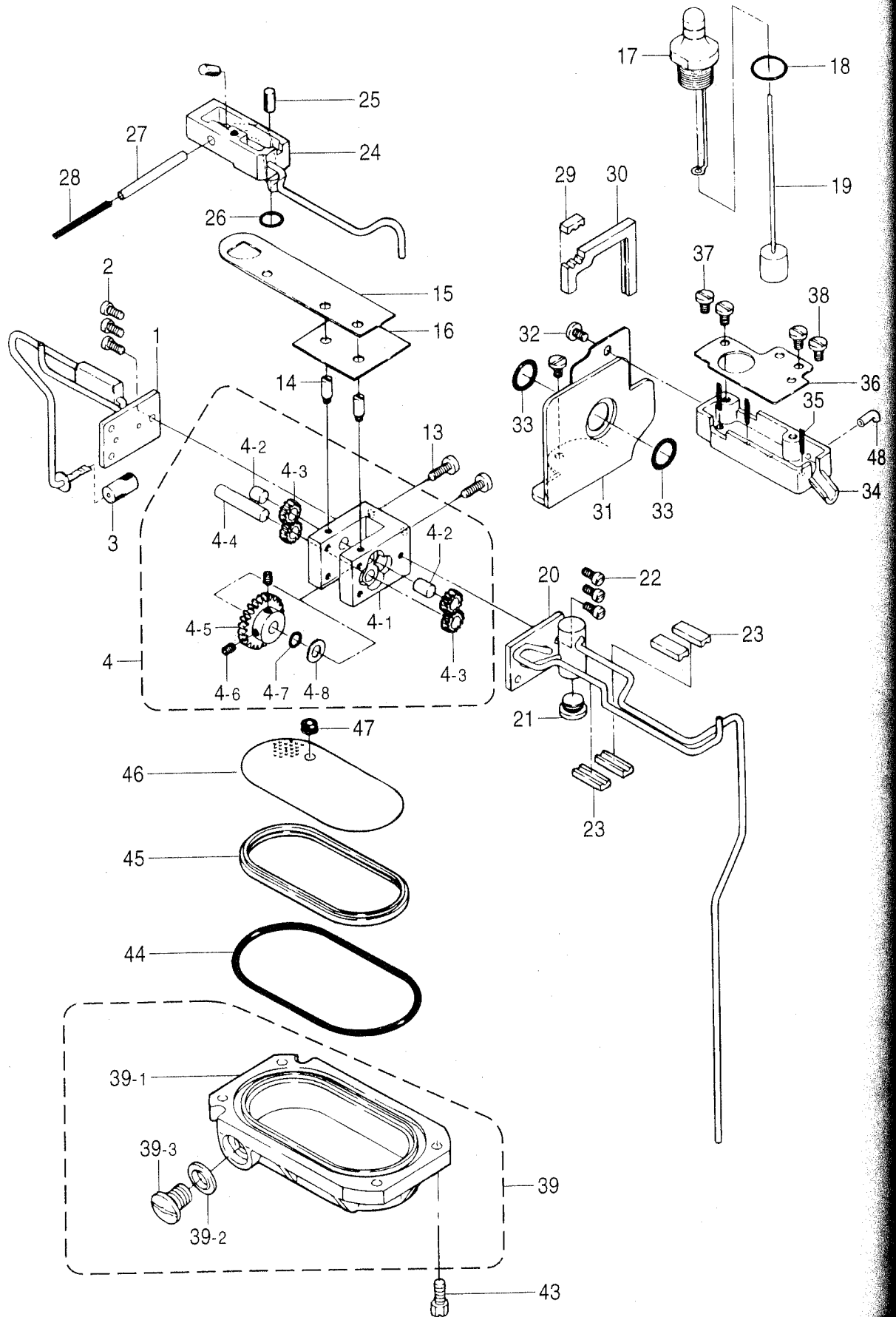

REF.NO.	CODE	Q'TY	ヒンメイ	NAME OF PARTS	RM
1	SP2380001	1	234007パイプBクミ	PIPE (B) ASSY	
2	SP0395001	3	001175-2ネジ3.57	SCREW	
3	SP2381000	1	234012フィルター	FILTER	
4	SP2382001	1	234000ポンプクミ	PUMP ASSY	
4-1	SP2383001	1	234001ポンプベース	PUMP BASE	
4-2	SP2384001	2	234003ヘイコウピン	PIN	
4-3	SP2385001	4	234002ギアS	GEAR (S)	
4-4	SP2386001	1	234006ヘイコウピン	PIN	
4-5	SP2387001	1	234004ギアL	GEAR (L)	
4-6	SP0360001	2	005461トメネジ4.37	SCREW	
4-7	SP1263000	1	200020オーリング	O RING	
4-8	SP1741001	1	234005ザガネ	WASHER	
13	SP0368001	2	005118ヒラネジ4.37	SCREW	
14	SP0460001	2	005580ピンネシ3.57	SCREW	
15	SP2389000	1	234062ガスケット	GASKET	
16	SP2390000	1	234042ガスケット	GASKET	
17	SP2391001	1	234033オイルゲージA	OIL GAUGE	
18	SP2392000	1	206162オーリング	O RING	
19	SP2393001	1	234038フロートクミ	FLOAT ASSY	
20	SP2394001	1	234084-91パイプF	PIPE	
21	SP0366001	1	005242ヒラネジ9.53	SCREW	
22	SP0395001	3	001175-2ネジ3.57	SCREW	
23	SP2395000	4	234059パイプアンナイ	PIPE GUIDE RUBBER	
24	SP2396001	1	234015アブラウケBクミ	OIL CUP	
25	SP2397000	2	234068キウユフエルト	FELT	
26	SP2398000	1	200030オーリング	O RING	
27	SP2399000	1	234019パイプ	PIPE	
28	SP1499000	1	202175クミヒモ	OIL WICK	
29	SP2400000	1	234061パイプアンナイ	PIPE GUIDE	
30	SP2401000	1	234060フエンスゴム	OIL GUARD RUBBER	
31	SP2402001	1	234054オイルフエンス	OIL GUARD ASSY	
32	SP0461001	2	005453ヒラネジ4.37	SCREW	
33	SP2403000	2	208272オーリング	O RING	
34	SP2404000	1	234057アブラウケF	OIL CUP	
35	SP1499000	3	202175クミヒモ	OIL WICK	
36	SP2405001	1	234058ブラケット	BRACKET	
37	SP0296001	2	002905ヒラネジ4.37	SCREW	
38	SP0296001	2	002905ヒラネジ4.37	SCREW	
39	SP2406001	1	234079-9Qオイルパン	OIL RESERVOIR ASSY	
39-1	SP2407001	1	234087-QDオイルパン	OIL RESERVOIR	
39-2	SP1462001	1	202287Aザガネ	WASHER	
39-3	SP0275001	1	0051388ヒラネシ9.53	SCREW	
43	SP0462001	4	005001ボルト4.76	BOLT	
44	SP2408000	1	234080オーリング	O RING	
45	SP2409000	1	234082フィルターウケ	FILTER SUPPORT	
46	SP2410000	1	234081フィルター	FILTER	
47	SP2411000	1	234083パイプアンナイ	PIPE GUIDE	
48	SP2412000	1	234032パイプ	PIPE	

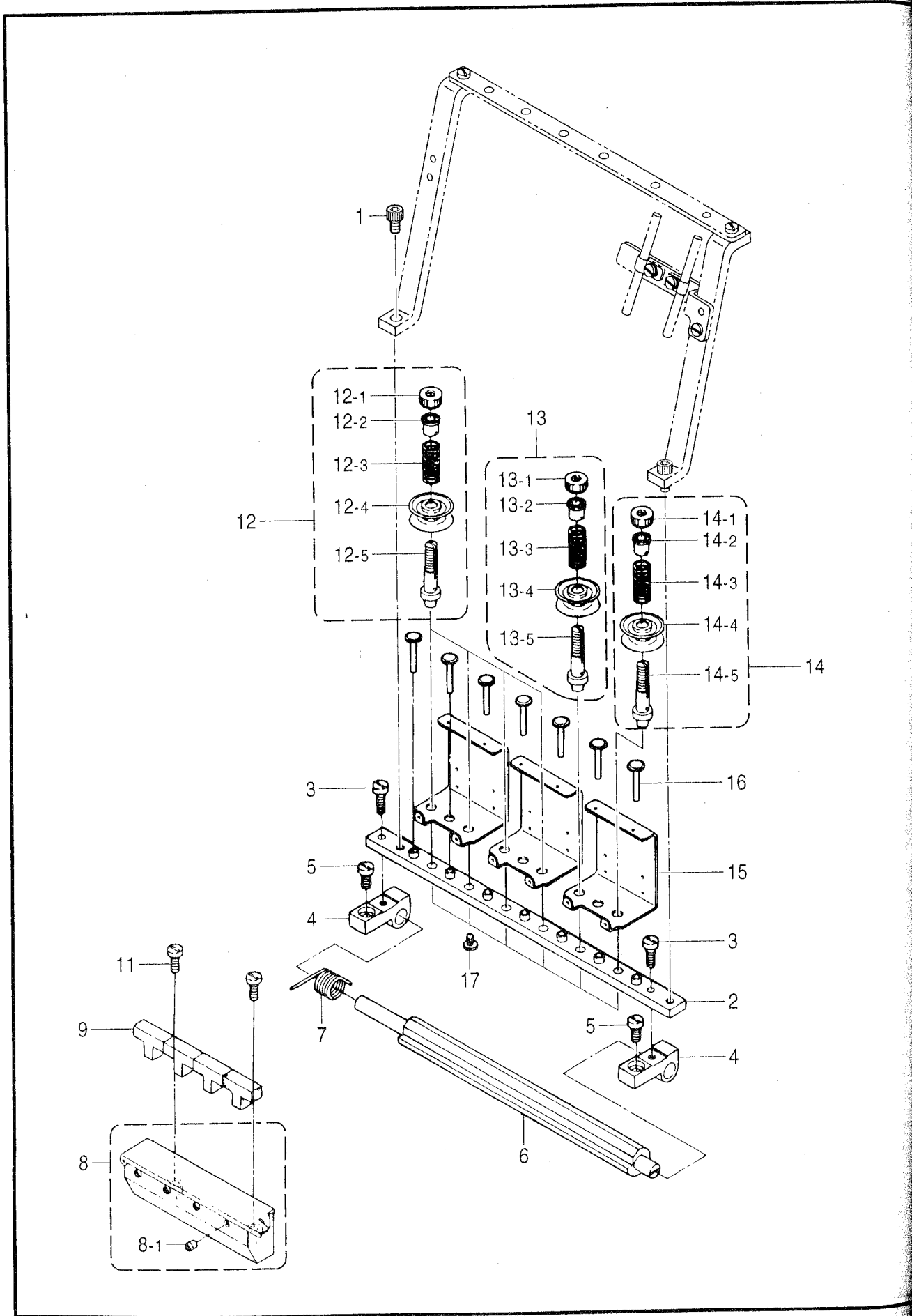

H. 糸調子関係 / Thread tension / Faderspannung / Tension du fil / Tensión del hilo

REF.NO.	CODE	Q'TY	ヒンメイ	NAME OF PARTS	RM
1	SP0463001	2	005457アナホルト5.95	BOLT	
2	SP2426001	1	234598-91イトミチタイ	THREAD GUIDE BRACKET	
3	SP0464001	2	002903ヒラネジ4.76	SCREW	
4	SP2427001	2	234501ブラケット	BRACKET	
5	SP0449001	2	005186ヒラネジ5.56	SCREW	
6	SP2428001	1	234502イトユルメジク	SHAFT/TENTION RELEASE	
7	SP2429001	1	234503ネジリバネ	SPRING	
8	SP2430001	1	234551-9Qタンククミ	SILICONE OIL RESERVOIR ASSY	
8-1	SP2431001	8	198205イトミチ	THREAD EYELET	
9	SP2432000	4	234554キユウユフエルト	OIL FELT	
11	SP0368001	2	005118ヒラネジ4.37	SCREW	
12	SP2433001	4	234604-91イトチヨウシ	THREAD TENSION ASSY	
12-1	SP0465001	4	003056チヨウシナツト	NUT	
12-2	SP2434001	4	101113トメパイプ	TENSION SPRING BUSHING	
12-3	SP2435001	4	234507アツシユクバネH	SPRING	
12-4	SP1511001	8	210319チヨウシサラ	TENSION DISC	
12-5	SP2437001	4	234602イトチヨウシボウ	THREAD GUIDE BAR	
13	SP2438001	1	234605-91イトチヨウシ	THREAD TENSION ASSY	
13-1	SP0465001	1	003056チヨウシナツト	NUT	
13-2	SP2434001	1	101113トメパイプ	TENSION SPRING BUSHING	
13-3	SP2439001	1	234509アツシユクバネM	SPRING	
13-4	SP1511001	2	210319チヨウシサラ	TENSION DISC	
13-5	SP2437001	1	234602イトチヨウシボウ	THREAD GUIDE BAR	
14	SP2440001	1	234606-91イトチヨウシ	THREAD TENSION ASSY	
14-1	SP0465001	1	003056チヨウシナツト	NUT	
14-2	SP2434001	1	101113トメパイプ	TENSION SPRING BUSHING	
14-3	SP2441001	1	234511アツシユクバネL	SPRING	
14-4	SP1511001	2	210319チヨウシサラ	TENSION DISC	
14-5	SP2437001	1	234602イトチヨウシボウ	THREAD GUIDE BAR	
15	SP2442001	3	234603イトミチ	THREAD GUIDE	
16	SP2443001	7	234601イトユルメピン	PIN	
17	SP0466001	6	005535ヒラネジ4.37	SCREW	



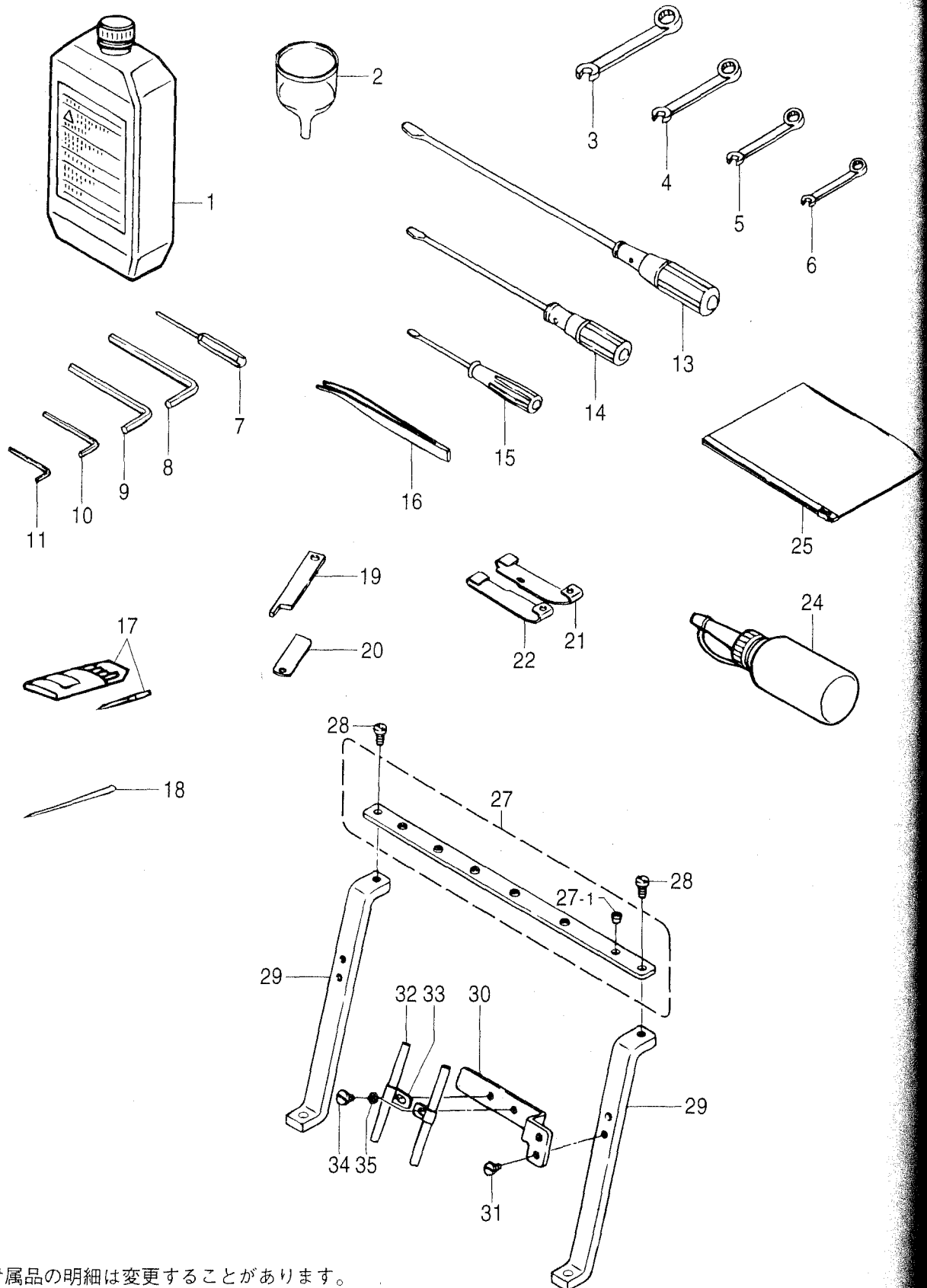

- ◎ 付属品の明細は変更することがあります。
- ◎ The details of included accessories are subject to change.
- ◎ Änderungen in der Aufstellung der Mitgelieferten Zubehöre sind vorbehalten.
- ◎ Les détails des accessoires inclus sont sujets à des changements.
- ◎ Los detalles de los accesorios incluidos pueden variar.

B  
 T  
 P1

## Z. 付属品関係 / Accessories / Zubehör / Accessoires / Accesorios

REF.NO.	CODE	Q'TY	ヒンメイ	NAME OF PARTS	RM
1	SP0051001	1	000412アブラカン	OIL CONTAINER	
2	SP0052000	1	000484ジヨウゴ	OIL FUNNEL	
3	SP0062001	1	000286スパナ9.5	WRENCH	
4	SP0005001	1	000285スパナ8	WRENCH	
5	SP0053001	1	000284スパナ7	WRENCH	
6	SP0054001	1	000283スパナ6	WRENCH	
7	SP0057001	1	000179ボウドライバ	DRIVER	
8	SP0060001	1	000319ボウスパナ5	WRENCH	
9	SP0055001	1	000200ボウスパ4.8	WRENCH	
10	SP0056001	1	000182ボウスパ3.2	WRENCH	
11	SP0061001	1	000322ボウスパ2.4	WRENCH	
13	SP0003001	1	000127ドライバー-L	SCREWDRIVER	
14	SP0058001	1	000128ドライバー-M	SCREWDRIVER	
15	SP0059001	1	000129ドライバー-S	SCREWDRIVER	
16	SP0002001	1	000131ピンセット	TWEEZERS	
17	※	2	ハリクミ	NEEDLE ASSY	
18	SP0041008	2	000660ハリ	NEEDLE	
19	SP2321001	1	236606ウワメス	UPPER KNIFE	
20	SP2193001	1	236608シタメス	LOWER KNIFE	
21	※	1	シューズR	SHOE (R)	
22	※	1	シューズL	SHOE (L)	
24	SP0063001	1	000178シリコンオイル	CONTAINER SILICONE	
25	SP0012001	1	000482アクセサリバッグ	ACCESSORY BAG	
27	SP2420001	1	234555イトミチクミ	THREAD GUIDE	
27-1	SP0029001	6	000506イトメアナ	THREAD GUIDE	
28	SP0355001	2	005117ヒラネジ4.37	SCREW	
29	SP2421001	2	234512ブラケット	BRACKET	
30	SP2422001	1	234513ブラケット	BRACKET	
31	SP0355001	2	005117ヒラネジ4.37	SCREW	
32	SP2423001	2	192120パイプ	PIPE	
33	SP2424001	2	206115ホルダー	HOLDER	
34	SP0296001	2	002905ヒラネジ4.37	SCREW	
35	SP1734001	2	201185ザガネ	WASHER	

< PD2用 / For PD2 >

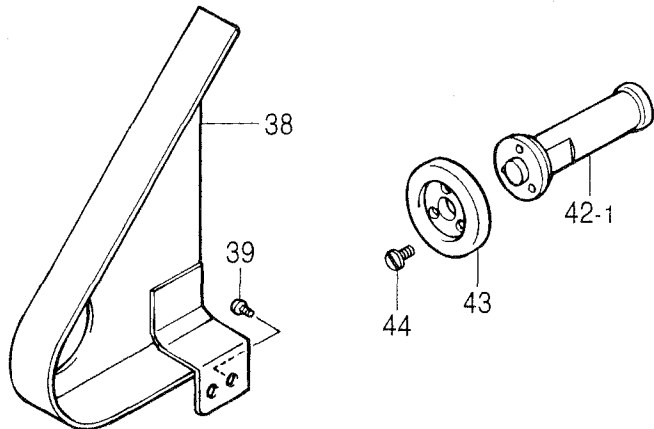

< オプションパーツ / OPTION PARTS >

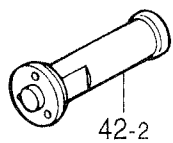

< PD3用 / For PD3 >

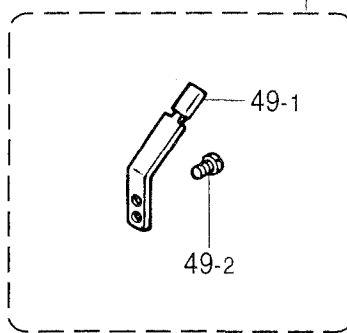
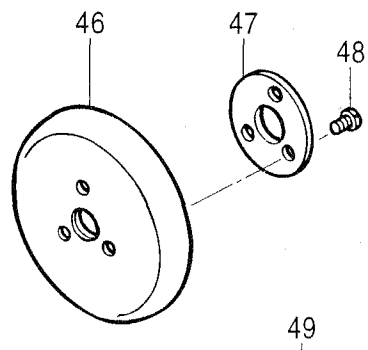

< オプションパーツ (出合ゲージセット) / OPTION PARTS (TIMING GAUGE SET) >

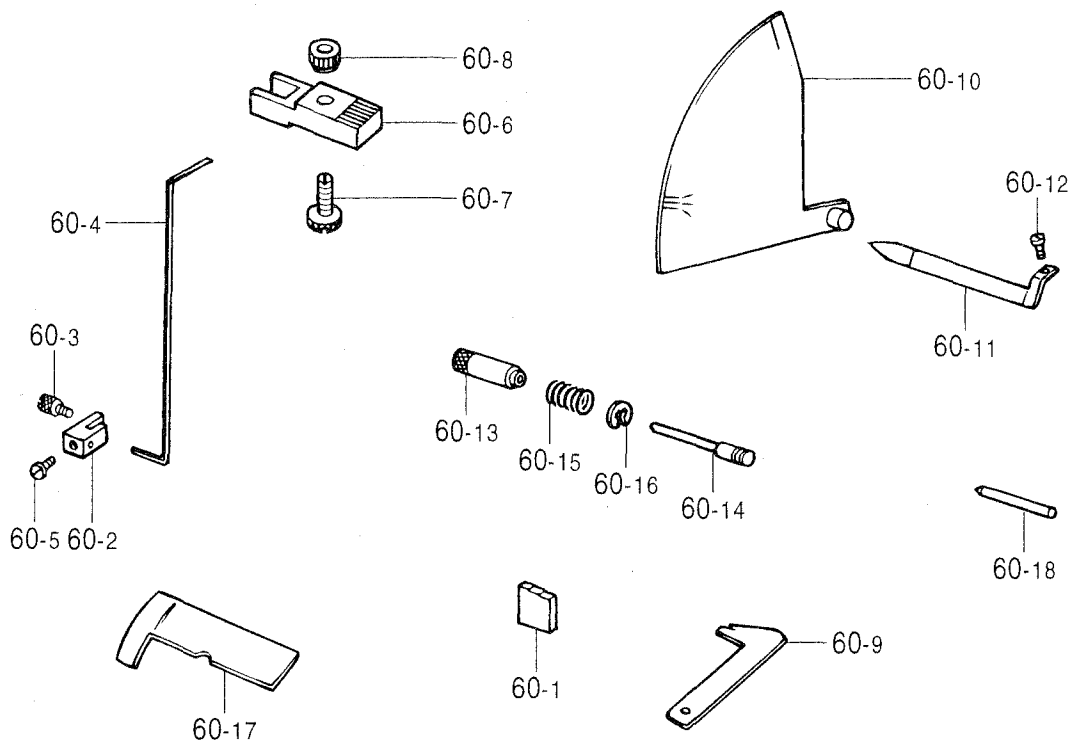

Z. 付属品関係 / Accessories / Zubehör / Accessoires / Accesorios

REF.NO.	CODE	Q'TY	ヒンメイ	NAME OF PARTS	RM
38	SP2450001	1	<PD2用> 235057AUDカバー	<FOR PD2> COVER	
39	SP0355001	2	005117ヒラネジ4.37	SCREW	
42-1	SP2451001	1	235042Aジク	SHAFT(M12-P1.75)	
43	SP2452001	1	235043-UDホイール	WHEEL	
44	SP0375001	3	005091ヒラネジ4.37	SCREW	
42-2	SP2459001	1	<PD2用オプションパーツ> 235042ジク	<OPTION PARTS FOR PD2> SHAFT(M14-P2)	
46	SP2453001	1	<PD3用> 231026-UAホイール	<FOR PD3> WASHER	
47	SP2454001	1	231027ザガネ	WASHER	
48	SP0464001	3	002903ヒラネジ4.76	SCREW	
49	SP2455001	1	235088-92ストツバA	STOPPER	
49-1	SP2457000	1	107723-05チューブ	TUBE	
49-2	SP0355001	2	005117ヒラネジ4.37	SCREW	
60	SP0075001	1	<オプションパーツ> デアイゲージセット	<OPTION PARTS> TIMING GAUGE SET	
60-1	SP0077001	1	000429ゲージ	GUGE	
60-2	SP0078001	1	000432シシンプラケット	BLAKET	
60-3	SP0497001	1	005603ヒラネジ4.37	SCREW, PLAIN SM4.37	
60-4	SP0088001	1	000430タイミングシシン	INDICTOR	
60-5	SP0452001	1	005141ヒラネジ2.38	SCREW	
60-6	SP0079001	1	000431ルーバゲージ	LOOPER GAUGE	
60-7	SP0498001	1	005602ヒラネジ6.35	SCREW, PLAIN SM6.35	
60-8	SP0465001	1	003056チョウシナット	NUT	
60-9	SP0080001	1	00433ヒキリヨウゲージ	GAUGE, DISTANCE	
60-10	SP0081001	1	000434フリリヨウゲージ	GAUGE, STROKE	
60-11	SP0082001	1	000437ルーバフリシシン	LOOPER STROKE INDICATOR	
60-12	SP0379001	1	001231ヒラネジ2.38	SCREW, PLAIN SM2.38	
60-13	SP0083001	1	00438ゼンゴゲージ	GAUGE, F-R	
60-14	SP0084001	1	000439ゼンゴバー	BAR, F-R	
60-15	SP2460001	1	137558アッシュクバネ	SPRING, COMPRESSION	
60-16	SP2461001	1	303097トメワ	RETAINING RING	
60-17	SP0085001	1	000440カクドゲージ	GAUGE, ANGLE	
60-18	SP0086001	1	000441ハリゲージ	GAUG, NEEDLE	

< PD2用 / For PD2 >

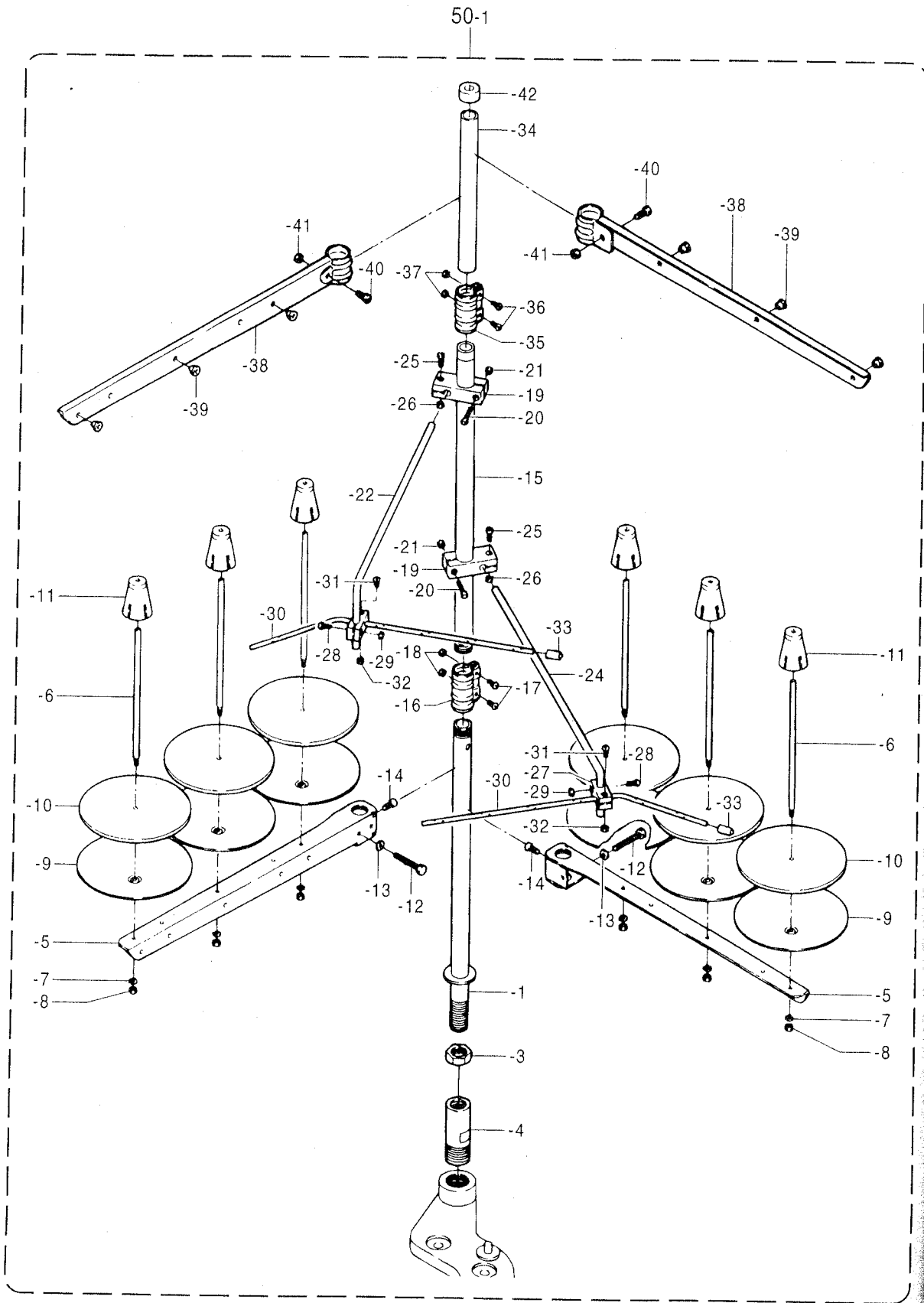

## Z. 付属品関係 / Accessories / Zubehör / Accessoires / Accesorios

REF.NO.	CODE	Q'TY	ヒンメイ	NAME OF PARTS	RM
			<PD2用>	<FOR PD2>	
50-1	SP0064001	1	000514A9Sイトタテクミ	THREAD STAND ASSY	
50-1-1	SP0014001	1	000503-SAスタンドD	THREAD STAND ROD	
50-1-3	SP0321001	1	004835ナツトM18	NUT	
50-1-4	SP0065001	1	000515Aツギテ	JOINT	
50-1-5	SP0016001	2	000505-SAブラケット	BRACKET	
50-1-6	SP0017001	6	000380Aイトタテボウ	SPOOL PIN	
50-1-7	SP1557001	6	201252バネザガネ	WASHER	
50-1-8	SP0306001	6	004803ナツトM4	NUT	
50-1-9	SP0018001	6	000381-SAウケザラ	SPOOL TRAY	
50-1-10	SP0019000	6	000507ウレタン	CUSHION	
50-1-11	SP0020001	6	000382-SAユレドメ	SPOOL RETAINING FIN	
50-1-12	SP0307001	2	007102ボルトM6	BOLT	
50-1-13	SP0021001	2	000512ザガネ	WASHER	
50-1-14	SP0308001	2	004022ヒラネジM6	SCREW	
50-1-15	SP0022001	1	000502-SAスタンドU	THRED STAND	
50-1-16	SP0023001	1	000504-SAジョイント	JOINT	
50-1-17	SP0309001	2	004021ヒラネジM5	SCREW	
50-1-18	SP0238001	2	004805ナツトM5	NUT	
50-1-19	SP0024001	2	000383-SAブラケット	BRACKET	
50-1-20	SP0311001	4	004014ヒラネジM4	SCREW	
50-1-21	SP0306001	4	004803ナツトM4	NUT	
50-1-22	SP0025001	1	000384ササエボウ	THREAD GUIDE BAR	
50-1-24	SP0066001	1	000384Aササエボウ	THREAD GUIDE BAR	
50-1-25	SP0312001	2	004012ヒラネジM4	SCREW	
50-1-26	SP0306001	2	004803ナツトM4	NUT	
50-1-27	SP0026001	2	000233-SAホルダー	HOLDER	
50-1-28	SP0312001	2	004012ヒラネジM4	SCREW	
50-1-29	SP0306001	2	004803ナツトM4	NUT	
50-1-30	SP0067001	2	000293イトミチボウ	THREAD GUIDE BAR	
50-1-31	SP0312001	2	004012ヒラネジM4	SCREW	
50-1-32	SP0306001	2	004803ナツトM4	NUT	
50-1-33	SP2458000	2	240534キャツブ	CAP	
50-1-34	SP0068001	1	000502ASAスタンドU	STAND	
50-1-35	SP0023001	1	000504-SAジョイント	JOINT	
50-1-36	SP0309001	2	004021ヒラネジM5	SCREW	
50-1-37	SP0238001	2	004805ナツトM5	NUT	
50-1-38	SP0028001	2	000527-SAブラケット	BRACKET	
50-1-39	SP0029001	6	000506イトメアナ	THREAD GUIDE	
50-1-40	SP0309001	2	004021ヒラネジM5	SCREW	
50-1-41	SP0238001	2	004805ナツトM5	NUT	
50-1-42	SP0030000	1	000386キャツブ	CAP	

< PD2 >

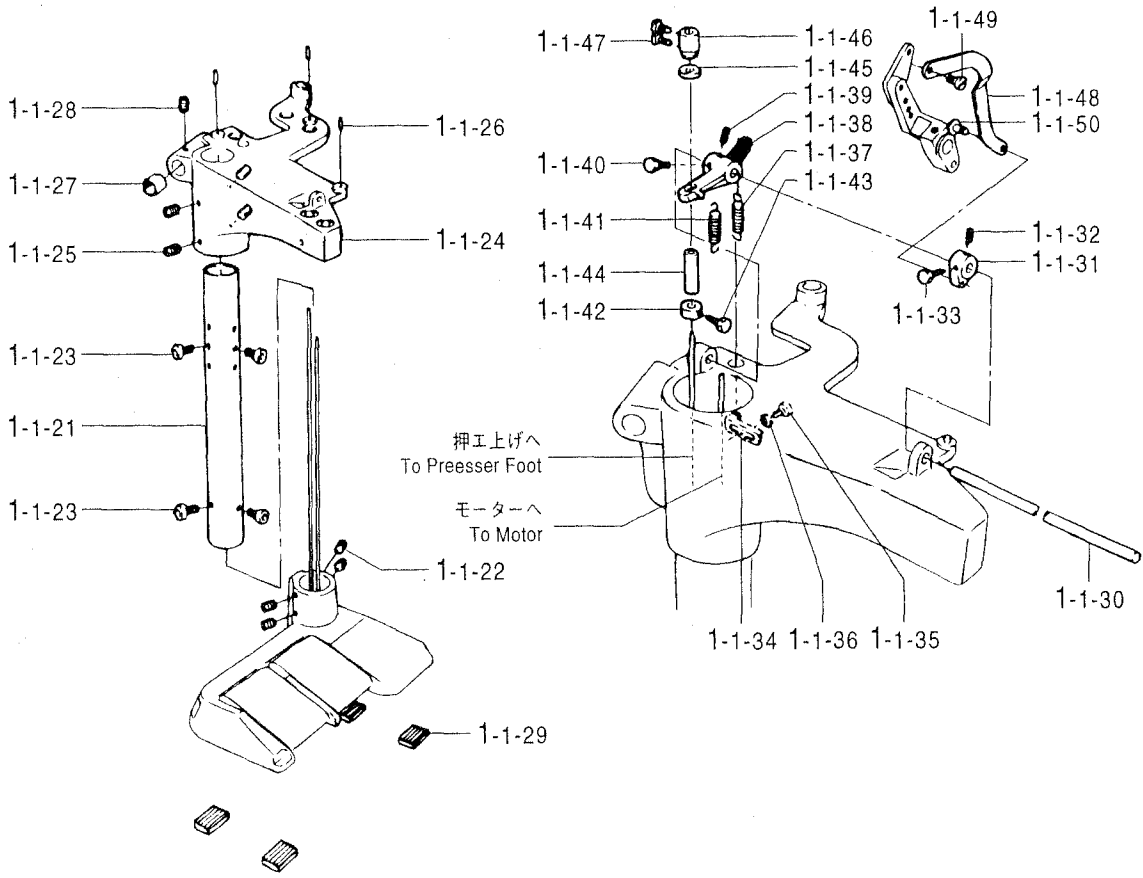
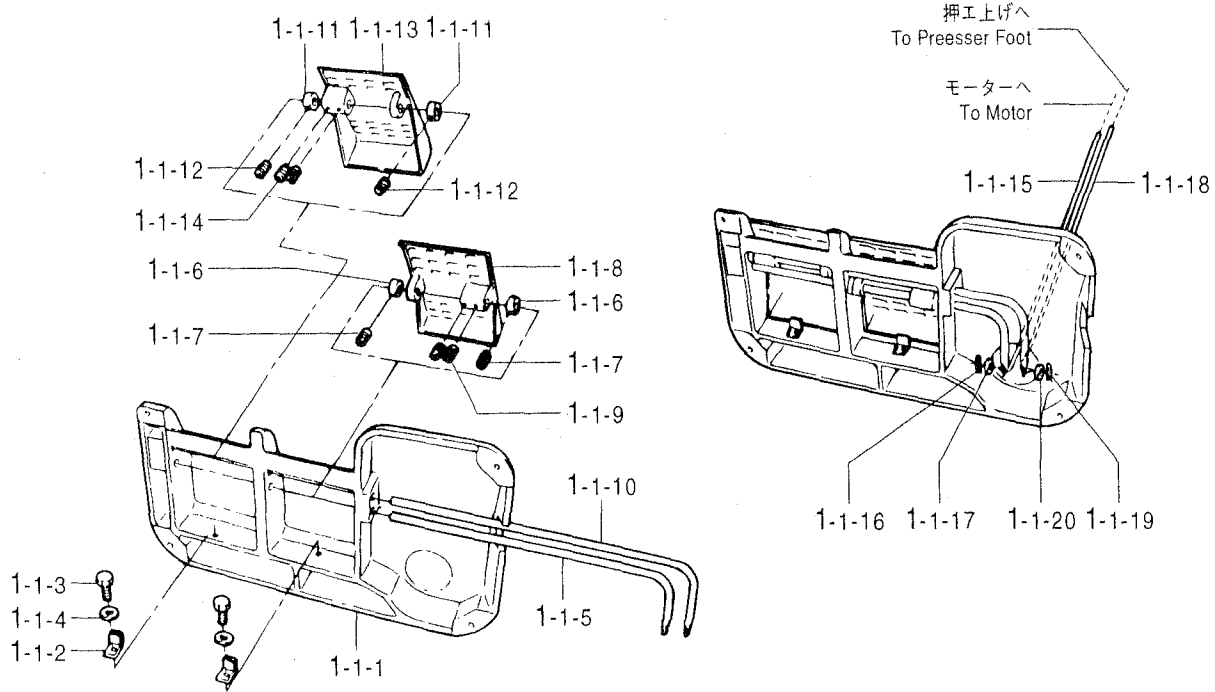

a. テーブル関係 / Power table / Motorgestell / Mécanisme du plateau de la machine /  
Mecanismo de la mesa de la máquina

REF.NO.	CODE	Q'TY	ヒンメイ	NAME OF PARTS	RM
			<PD2用>	<FOR PD2>	
1	SP2555001	1	ペDESTアルテーブルセット	TABLE SET	
1-1	SP2500001	1	235000B9Uペデクミ	PEDESTAL ASSY	
1-1-1	SP2501001	1	235001-UDドダイ	BRACKET	
1-1-2	SP2502001	2	235014ブラケット	BRACKET	
1-1-3	SP0468001	2	004316ボルトM10	BOLT	
1-1-4	SP2503001	2	235017ザガネ	WASHER	
1-1-5	SP2504001	1	235012ペダルジク	PEDAL SHAFT	
1-1-6	SP2505001	2	235013カラー	COLLAR	
1-1-7	SP0469001	2	004521トメネジM6	SCREW	
1-1-8	SP2506001	1	235011-UDペダル	PEDAL	
1-1-9	SP0470001	2	004520トメネジM8	SCREW	
1-1-10	SP2507001	1	235029ペダルジク	PEDAL SHAFT	
1-1-11	SP2505001	2	235013カラー	COLLAR	
1-1-12	SP0469001	2	004521トメネジM6	SCREW	
1-1-13	SP2509001	1	235028-UDペダル	PEDAL	
1-1-14	SP0470001	2	004520トメネジM8	SCREW	
1-1-15	SP2510001	1	235018ジク	SHAFT	
1-1-16	SP2511001	1	235019ワリピン	PIN	
1-1-17	SP2512001	1	235040ザガネ	WASHER	
1-1-18	SP2513001	1	235030ジク	SHAFT	
1-1-19	SP2511001	1	235019ワリピン	PIN	
1-1-20	SP2512001	1	235040ザガネ	WASHER	
1-1-21	SP2514001	1	235002-UDシチュウ	STAND POST	
1-1-22	SP0471001	4	004517トメネジM12	SCREW	
1-1-23	SP0472001	4	004518アナボルトM6	SCREW	
1-1-24	SP2515001	1	235003-UDブラケット	BRACKET	
1-1-25	SP0471001	4	004517トメネジM12	SCREW	
1-1-26	SP2516001	3	235004ヘイコウピン	PIN	
1-1-27	SP2517001	1	235005スリーブ	SLEEVE	
1-1-28	SP0473001	1	004519トメネジM10	SCREW	
1-1-29	SP2518000	4	235068クツシヨングム	CUSHION.WASHER	
1-1-30	SP2519001	1	235036ジク	SHAFT	
1-1-31	SP2520001	1	235037-UDレバー	LEVER	
1-1-32	SP0469001	1	004521トメネジM6	SCREW	
1-1-33	SP0474001	1	004317ボルトM6	BOLT	
1-1-34	SP2521001	1	235039ブラケット	BRACKET	
1-1-35	SP0472001	1	004518アナボルトM6	SCREW	
1-1-36	SP2512001	1	235040ザガネ	WASHER	
1-1-37	SP2523001	1	235041ヒツバリバネ	SPRING	
1-1-38	SP2524001	1	235032-UDクランク	CRANK	
1-1-39	SP0469001	1	004521トメネジM6	SCREW	
1-1-40	SP0474001	1	004317ボルトM6	BOLT	
1-1-41	SP2525001	1	235033ヒツバリバネ	SPRING	
1-1-42	SP2526001	1	235031カラー	COLLAR	
1-1-43	SP0475001	1	004302ボルトM5	BOLT	
1-1-44	SP2527000	1	235034チユープ	TUBE	
1-1-45	SP2528000	1	235025クツシヨングム	CUSHION WASHER	
1-1-46	SP2529001	1	235035カラー	COLLAR	
1-1-47	SP0335001	2	004320ボルトM6	BOLT	
1-1-48	SP2530001	1	235069リンク	LINK	
1-1-49	SP0476001	1	005581ダンネシ4.37	SCREW	
1-1-50	SP0477001	1	005582ダンネシ4.37	SCREW	



< PD2 >

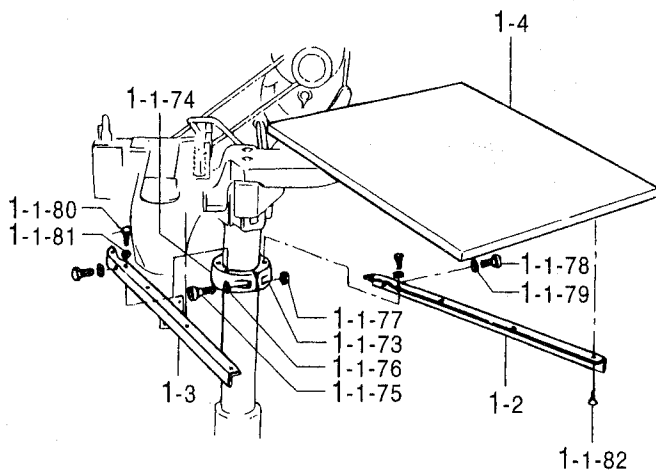
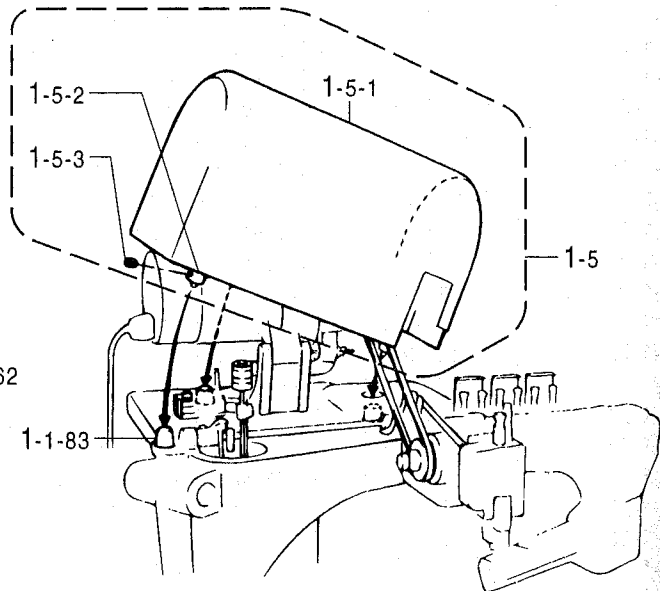
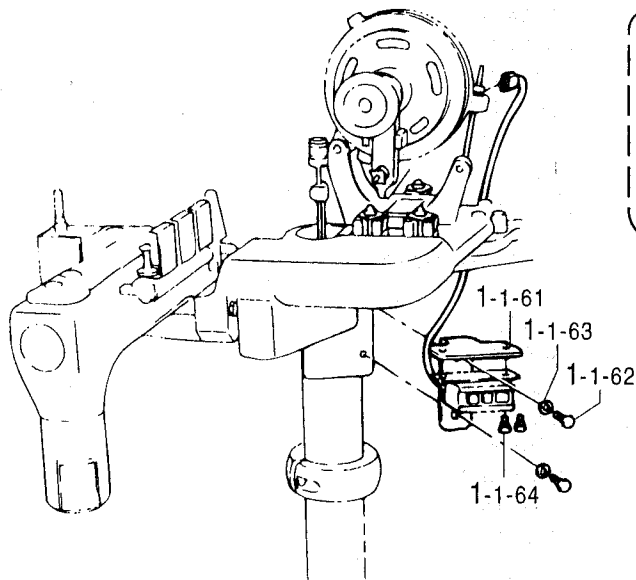
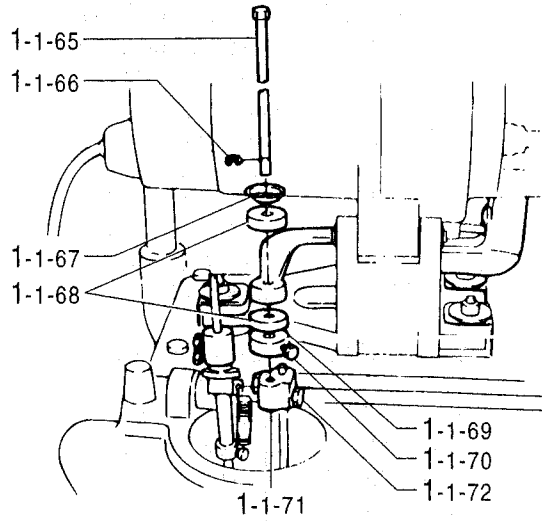
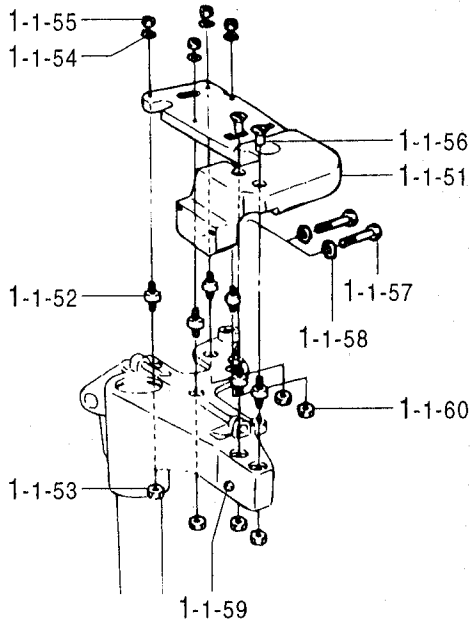

< PD2用クラッチモーター (オプションパーツ)  
/ CLUTCH MOTOR FOR PD2 (OPTION PARTS) >

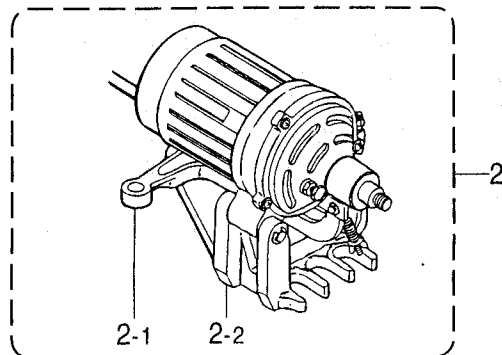

REF.NO.	CODE	Q'TY	品名	NAME OF PARTS	RM
			<PD2用>	<FOR PD2>	
51	SP2531001	1	235006-UDブラケット	BRACKET	
52	SP2532001	6	235007クツシヨンゴム	CUSHION WASHER	
53	SP0478001	6	004807ナツトM10	NUT	
54	SP2533001	4	235009ハツキザガネ	WASHER	
55	SP0479001	4	004816ナツトM10	NUT	
56	SP2534001	2	235010マルナツト	NUT	
57	SP0480001	2	005585ボルト9.53	BOLT	
58	SP2533001	2	235009ハツキザガネ	WASHER	
59	SP0481001	1	005564ボルトM10	BOLT	
60	SP0478001	1	004807ナツトM10	NUT	
61	SP2536001	1	235105ブラケット	BRACKET	
62	SP0468001	2	004316ボルトM10	BOLT	
63	SP2503001	2	235017ザガネ	WASHER	
64	SP0482001	2	007074ヒラネジM5	SCREW	
65	SP2538001	1	235021ジク	SHAFT	
66	SP2539001	1	306575トメワ	STOP RING	
67	SP2540001	1	235024ウケザラ	CUP	
68	SP2528000	2	235025クツシヨンゴム	CUSHION WASHER	
69	SP2542001	1	235026カラー	COLLAR	
70	SP0474001	1	004317ボルトM6	BOLT	
71	SP2543001	1	235027-UDブラケット	BRACKET	
72	SP0336001	2	004304ボルトM6	BOLT	
73	SP2544001	1	235062-UDフランジ	FLANGE	
74	SP2545001	1	235063-UDフランジ	FLANGE	
75	SP0224001	2	004523アナボルトM6	BOLT	
76	SP2546001	2	235064ハツキザガネ	WASHER	
77	SP0483001	2	004818ナツトM6	NUT	
78	SP0474001	3	004317ボルトM6	BOLT	
79	SP2512001	3	235040ザガネ	WASHER	
80	SP0474001	3	004317ボルトM6	BOLT	
81	SP2512001	3	235040ザガネ	WASHER	
82	SP0484001	6	004916サラモクネジ	WOOD SCREW	
1-83	SP2552000	3	235056クツシヨンゴム	CUSHION WASHER	
2	SP2547001	1	235065-UDブラケット	BRACKET	
3	SP2549001	1	235066-UDブラケット	BRACKET	
4	SP2550001	1	235067Aテーブル	TABLE	
5	SP2553001	1	235090B9Uカバークミ	COVER ASSY	
5-1	SP2554001	1	235047-UDモータカバ	MOTOR COVER	
5-2	SP2551001	3	235055カラー	COLLAR	
5-3	SP0220001	3	004522トメネジM6	SCREW	
			<PD2用クラッチモータ>	<CLUTCH MOTOR FOR PD2>	
			<1ソウ100V>	<100V 1PHASE>	
	SP2980001	1	クラッチモータクミ	CLUTCH MOTOR SET	
			<3ソウ200V>	<200V 3PHASE>	
	SP2983001		クラッチモータクミ	CLUTCH MOTOR SET	
			<3ソウ220V>	<220V 3PHASE>	
	SP2984001		クラッチモータクミ	CLUTCH MOTOR SET	
			<3ソウ380V>	<300V 3PHASE>	
	SP2985001		クラッチモータクミ	CLUTCH MOTOR SET	
			<1ソウ220V>	<220V 1PHASE>	
	SP2986001		クラッチモータクミ	CLUTCH MOTOR SET	
1	SP2981001	1	モータレバー	MOTOR LEVER	
2	SP2982001	1	モータベース	MOTOR BASE	

< PD3 >

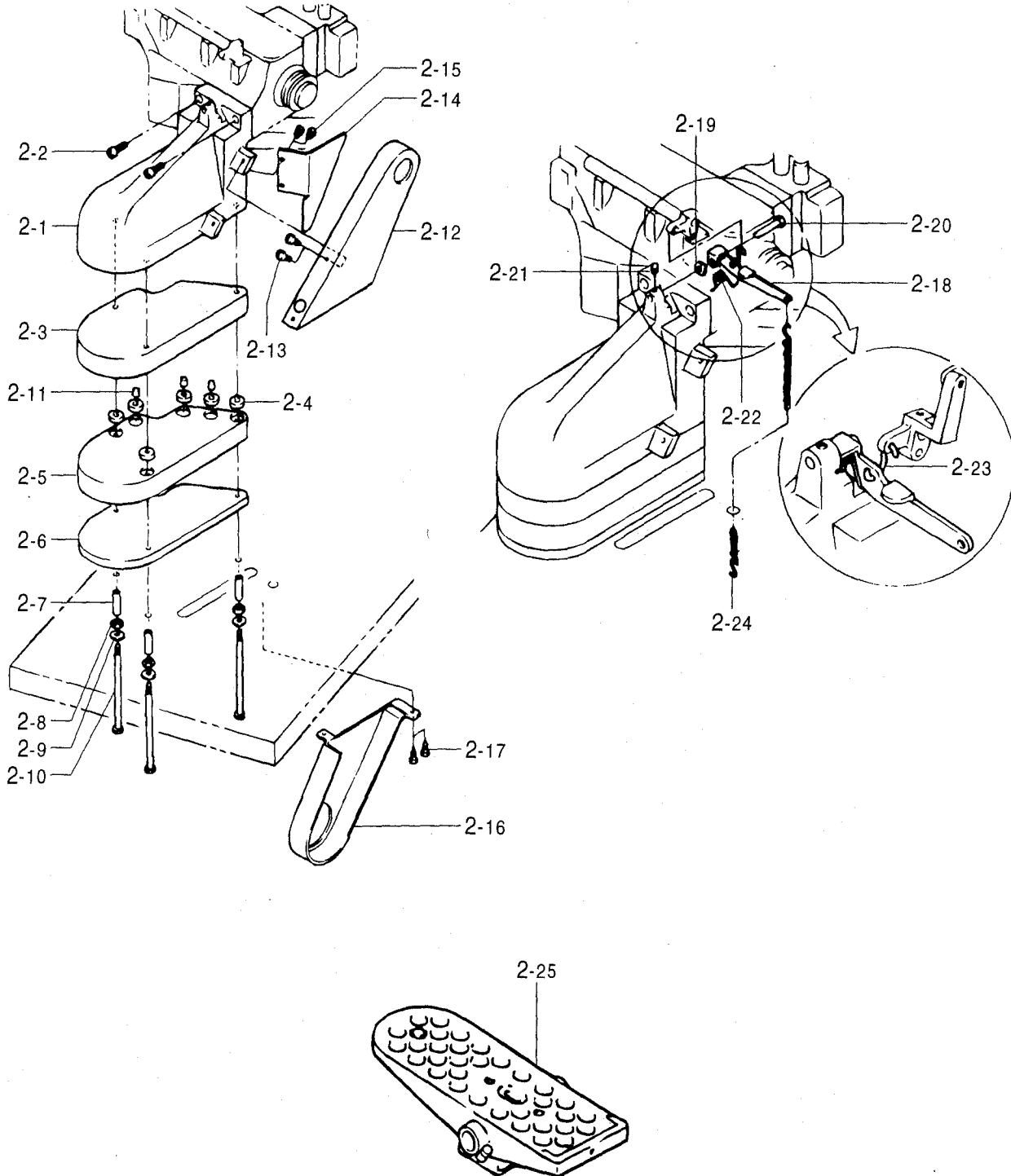











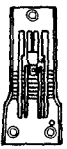
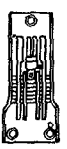
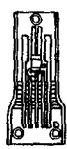
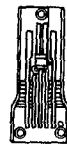

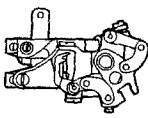
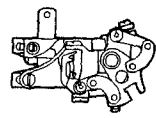
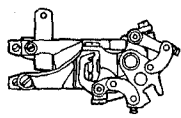
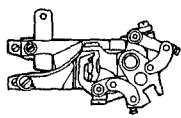
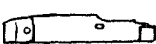

ブル関係 / Power table / Motorgestell / Mécanisme du plateau de la machine /  
 anismo de la mesa de la máquina

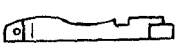
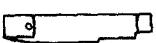
D.	CODE	Q'TY	ヒンメイ	NAME OF PARTS	RM
			<PD3用>	<FOR PD3>	
	SP2573001	1	235071D9Qダイクミ	TABLE TYPE MOUNTING ASSY	
	SP2556001	1	235073-QDトリツケタイ	MACHINE REST BOARD	
	SP0485001	2	005392ボルト9.53	BOLT	
	SP2557001	1	235075AホジヨイタU	SUPPORT PLATE	
	SP2558000	6	205764クツシヨンゴム	CUSHION WASHER	
	SP2559000	1	235076AホジヨイタD	SUPPORT PLATE	
	SP2574000	1	235077クツシヨンゴム	CUSHION WASHER	
	SP2560000	3	235074チューブ	TUBE	
	SP2561000	3	202765クツシヨンゴム	CUSHION WASHER	
	SP2562001	3	202700ザガネ	WASHER	
	SP0486001	3	004323ボルトM8	BOLT	
	SP2563001	3	235081ヘイコウピン	PIN	
	SP2564001	1	235078A9UカバーU	COVER	
	SP0368001	2	005118ヒラネジ4.37	SCREW	
	SP2565001	1	235079-UDカバーS	COVER	
	SP0355001	2	005117ヒラネジ4.37	SCREW	
	SP2566001	1	235080-UDカバーD	COVER	
	SP0487001	2	004906モクネジ4.8	WOOD SCREW	
	SP2567001	1	201160Bレバー	LEVER	
	SP2568001	1	202868ザガネ	WASHER	
	SP2569001	1	201161ダンツキピン	PIN	
	SP0277001	1	005060トメネジ5.56	SCREW	
	SP2570001	1	235541トーションバネ	SPRING	
	SP2571001	1	205702リング	LINK	
	SP0070001	1	000392Aクサリ	CHAIN	
	SP0010001	1	000480ペダル	PEDAL	

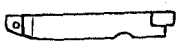
ソフ  
 3 B  
 TA  
 PIE  
 PIE

ケーン部品一覧表 / Gauge parts List / Lehrenliste  
 / Liste des Pièces decartment / Lista d'ePiezas de calibradores

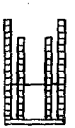
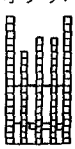
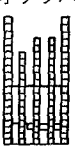
サブクラス Sub-Class	B941 1-52	B941 1-60	B942 1-52	B942 2-52
B-60 針留 Needle Holder	SP2150001 236601-52 ハリドメ 	SP2151001 236601B60 ハリドメ 	SP2150001 236601-52 ハリドメ 	←
B-62,Z-17 針組 Needle Assy	SP0042509 00659Eハリクミ	←	←	←
B-64 針板 Needle Plate	SP2152001 236001A52 ハリイタ 	SP2153001 236001A60 ハリイタ 	SP2154001 236049-52 ハリイタ 	SP2155001 236048-52 ハリイタ 
F-66 針板爪 Needle Plate Finger	SP2135001 236101 ハリイタツメ 	SP2136001 236101B ハリイタツメ 	SP2137001 236114-52 ハリイタツメ 	←
C-29 押工組 Presser Foot Assy	SP2186001 236301E オサエクミ 	SP2208001 236301H60 オサエクミ 	SP2212001 236347-52 オサエクミ 	SP2223001 236346-52 オサエクミ 
Z-20 押エシューズ R Shoe ( R )	SP2210001 236612E シューズR 	←	SP2216001 236645 シューズR 	SP2225001 236641 シューズR 
Z-21 押エシューズ L Shoe ( L )	SP2211001 236613E シューズL 	←	SP2217001 236644 シューズL 	SP2226001 236640 シューズL 
D-25 主送り歯 Main Feed Dog	SP2280001 236200B18 オクリバ 	←	SP2283001 236237-18 オクリバ 	SP2284001 236235-18 オクリバ 
D-35 差動送り歯 Differential Feed Dog	SP2281001 236201 オクリバ 	←	SP2285001 236238-18 オクリバ 	SP2286001 236236-18 オクリバ 

索引 / INDEX / VERZEICHNIS  
/ INDEX / INDICE

CODE	REF.NO.	Page
SP0375001	A -78	4
	Z -44	34
SP0376001	A -67	6
	A -96	6
SP0377001	A -72	4
SP0378001	A -87	4
SP0379001	A -89	6
	B -80	10
	C -32	12
	F -7	24
	F -9	24
	F -68	26
	Z -60-12	34
SP0381001	A -94	6
SP0382001	A -101	4
SP0383001	B -2	8
SP0384001	B -3	8
SP0385001	B -4	8
SP0386001	B -8	8
SP0387001	B -19-3	8
	B -89	10
SP0388001	B -20	8
SP0389001	B -25	8
	B -28	8
	C -29-5	14
	C -29-5	16
SP0390001	B -27-1	8
	C -15	12
SP0391001	B -30	8
SP0392001	B -40-1	10
	B -76	10
SP0393001	B -45	10
	F -51	24
SP0394001	B -56	10
	F -41	24
SP0395001	B -57-1	10
	G -2	28
	G -22	28
SP0396001	B -60-1	10
SP0397001	B -65	10
SP0398001	B -67	10
SP0399001	B -78	10
	B -91	10
SP0401001	B -83	10
SP0402001	B -84	10
SP0403001	B -85	10
SP0404001	C -4-1	12
SP0405001	C -7	12
SP0406001	C -10	12
SP0407001	C -12	12
	F -38	24
	F -39	24
SP0408001	C -21	12
SP0409001	C -24	12
SP0410001	C -26	12
SP0411001	C -28	12
SP0412001	C -29-2	14
	C -29-2	16
SP0414001	C -29-8	14
	C -29-8	16
SP0415001	C -29-12	14
	C -29-12	16
SP0416001	C -29-15	14

CODE	REF.NO.	Page
SP0416001	C -29-15	16
SP0417001	C -29-17	14
	C -29-17	16
	D -19	18
SP0418001	C -29-20	14
	C -29-20	16
SP0419001	C -29-25	14
	C -29-25	16
	C -31	12
SP0420001	C -29-26	14
	C -29-26	16
	E -39	22
	F -65	26
SP0421001	C -29-28	14
	C -29-28	16
SP0422001	D -1-1-1	18
	D -64-1-1	20
SP0423001	D -1-3	18
	D -64-4	20
	E -12-3	22
	F -22	24
	F -26-3	24
SP0424001	D -1-4-1	18
	D -64-5-1	20
	E -5-1	22
	E -10-1	22
	E -12-1-1	22
	E -12-4-1	22
	F -26-1	24
	F -26-4	24
SP0425001	D -1-6	18
	D -64-7	20
	E -12-6	22
	F -26-6	24
SP0426001	D -1-9	18
	F -26-9	24
SP0427001	D -16	18
SP0428001	D -22	18
	D -32	18
SP0429001	D -23	18
	D -33	18
SP0431001	D -28	18
SP0432001	D -43	18
	F -46	24
SP0433001	D -45	18
SP0434001	D -47	18
SP0435001	D -49	18
SP0436001	D -60	18
	F -5	24
SP0437001	D -61	18
SP0439001	D -68	20
SP0440001	D -85	20
SP0441001	D -86	20
SP0442001	E -3	22
SP0443001	E -7	22
SP0444001	E -9	22
	E -23	22
SP0446001	E -30	22
SP0447001	E -44	22
SP0448001	E -45	22
SP0449001	F -3	24
	H -5	30
SP0450001	F -11	24

CODE	REF.NO.	Page
SP0451001	F -13	24
SP0452001	F -16	24
	Z -60-5	34
SP0453001	F -44	24
SP0454001	F -48-1	24
SP0455001	F -54	24
SP0456001	F -59	24
SP0457001	F -61-1	24
SP0458001	F -63	24
SP0459001	F -64	26
SP0460001	G -14	28
SP0461001	G -32	28
SP0462001	G -43	28
SP0463001	H -1	30
SP0464001	H -3	30
	Z -48	34
SP0465001	H -12-1	30
	H -13-1	30
	H -14-1	30
	Z -60-8	34
SP0466001	H -17	30
SP0468001	a -1-1-3	40
	a -1-1-62	42
SP0469001	a -1-1-7	40
	a -1-1-12	40
	a -1-1-32	40
	a -1-1-39	40
SP0470001	a -1-1-9	40
	a -1-1-14	40
SP0471001	a -1-1-22	40
	a -1-1-25	40
SP0472001	a -1-1-23	40
	a -1-1-35	40
SP0473001	a -1-1-28	40
SP0474001	a -1-1-33	40
	a -1-1-40	40
	a -1-1-70	42
	a -1-1-78	42
	a -1-1-80	42
SP0475001	a -1-1-43	40
SP0476001	a -1-1-49	40
SP0477001	a -1-1-50	40
SP0478001	a -1-1-53	42
	a -1-1-60	42
SP0479001	a -1-1-55	42
SP0480001	a -1-1-57	42
SP0481001	a -1-1-59	42
SP0482001	a -1-1-64	42
SP0483001	a -1-1-77	42
SP0484001	a -1-1-82	42
SP0485001	a -2-2	44
SP0486001	a -2-10	44
SP0487001	a -2-17	44
SP0495001	C -29-33	16
SP0496001	C -35	12
SP0497001	Z -60-3	34
SP0498001	Z -60-7	34
SP1116001	B -6	8
SP1142000	B -44	10
SP1263000	G -4-7	28
SP1290000	D -39	18
	D -83	20
SP1393000	E -37	22

索引 / INDEX / VERZEICHNIS  
/ INDEX / INDICE

ック  
OK  
OG  
ES  
AS

CODE	REF.NO.	Page
SP1450000	A -18	2
	B -17	8
	B -55	10
	C -29-29	14
	C -29-29	16
	D -18	18
	E -38	22
	F -25	24
SP1452001	D -15	18
	D -66	20
SP1462001	A -5	2
	G -39-2	28
SP1499000	B -54	10
	F -24	24
	G -28	28
	G -35	28
SP1511001	H -12-4	30
	H -13-4	30
	H -14-4	30
SP1557001	Z -50-1-7	36
	Z -50-2-7	38
SP1734001	Z -35	32
SP1741001	G -4-8	28
SP1874001	D -69	20
SP2002001	A -3	2
SP2010000	A -6	2
SP2011000	A -8	2
	B -72	10
SP2012000	A -10	2
SP2013001	A -11	2
SP2014001	A -14	2
SP2015001	A -15	2
SP2016001	A -1-8	2
SP2017000	A -16	2
SP2019001	A -1-12	2
SP2024000	A -17	2
SP2026000	A -1-18	2
SP2027001	A -1-19	2
	A -22-5	2
SP2028001	A -19	2
SP2033000	A -23	2
	A -24	2
SP2034001	A -22-4	2
SP2035001	A -25	2
SP2036000	A -26	2
SP2037001	A -22-6	2
SP2038001	A -22-7	2
SP2039001	A -28	2
SP2040000	A -21	2
SP2041001	A -32	4
SP2042001	A -32-1	4
SP2043000	A -32-2	4
	A -46-2	4
SP2044000	A -36	4
	A -49	4
SP2045000	A -37	4
SP2046001	A -38	4
SP2047001	A -39	4
SP2048001	A -42	4
SP2049001	A -46	4
SP2050001	A -46-1	4
SP2051000	A -50	4
SP2052001	A -51	4

CODE	REF.NO.	Page
SP2053000	A -52	4
SP2054001	A -54	4
SP2055001	A -54-1	4
SP2056001	A -54-2	4
SP2057000	A -55	4
SP2058001	A -57	4
SP2059000	A -58	4
SP2060001	A -60	4
SP2061000	A -62	4
SP2062001	A -63	4
SP2063001	A -65	4
SP2064001	A -66	6
SP2065001	A -68	6
	A -97	6
SP2066001	A -69	6
	A -98	6
SP2067001	A -71	4
SP2068001	A -73	4
SP2069001	A -75	4
SP2070001	A -77	4
SP2072001	A -80	4
SP2073000	A -82	4
SP2074001	A -83	4
SP2075001	A -84	4
SP2076001	A -86	6
SP2077001	A -88	4
SP2078000	A -90	4
SP2079001	A -92	6
SP2080001	A -93	6
SP2081001	A -95	6
SP2082001	A -100	4
SP2100001	B -1	8
SP2101001	B -5	8
SP2103001	B -7	8
SP2104001	B -9	8
SP2105000	B -10	8
SP2106000	B -11	8
SP2107000	B -12	8
SP2108000	B -13	8
SP2109000	B -15	8
SP2110001	B -16	8
SP2111001	B -18	8
SP2112001	B -19	8
SP2113001	B -19-1	8
SP2114001	B -19-2	8
SP2115001	B -21	8
SP2116001	B -22	8
SP2117001	B -23	8
SP2118001	B -24	8
SP2119001	B -27	8
SP2120001	B -29	8
SP2121001	B -40	10
SP2122001	B -41	10
SP2123001	B -42	10
SP2124001	B -43	10
SP2125001	B -46	10
SP2126001	B -47	10
SP2127001	B -48	10
SP2128000	B -49	10
SP2129001	B -50	10
SP2130001	B -52	10
SP2131001	B -53	10
SP2132001	B -57	10

CODE	REF.NO.	Page
SP2133001	B -58	10
SP2134001	B -59	10
SP2138001	B -68	10
SP2139001	B -69	10
SP2140001	B -73	10
SP2141000	B -70	10
SP2142001	B -75	10
SP2143001	B -77	10
SP2144001	B -79	10
SP2145001	B -81	10
SP2146001	B -82	10
SP2147001	B -86	10
SP2148001	B -88	10
SP2149001	B -90	10
SP2170001	C -1	12
SP2171001	C -2	12
SP2172001	C -3	12
SP2173001	C -4	12
SP2174001	C -6	12
SP2175001	C -9	12
SP2176001	C -11	12
SP2177001	C -13	12
SP2178001	C -14	12
SP2179001	C -16	12
SP2180001	C -18	12
SP2181001	C -19	12
SP2182001	C -22	12
SP2183001	C -23	12
SP2184001	C -25	12
SP2185001	C -27	12
SP2187001	C -29-1	14
SP2188001	C -29-3	14
SP2189001	C -29-4	14
SP2190001	C -29-6	14
SP2191001	C -29-7	14
SP2192001	C -29-9	14
	C -29-9	16
SP2193001	C -29-10	14
	C -29-10	16
	Z -20	32
SP2194001	C -29-11	14
SP2195001	C -29-13	14
SP2196001	C -29-14	14
	C -29-14	16
SP2197001	C -29-16	14
	C -29-16	16
SP2198001	C -29-18	14
	C -29-18	16
SP2199001	C -29-19	14
SP2200001	C -29-21	14
	C -29-21	16
SP2201001	C -29-22	14
	C -29-22	16
SP2202001	C -29-23	14
	C -29-23	16
SP2203001	C -29-24	14
	C -29-24	16
SP2204001	C -29-27	14
	C -29-27	16
SP2205000	C -29-30	14
	C -29-30	16
SP2206001	C -29-31	14
	C -29-31	16

索引 / INDEX / VERZEICHNIS  
/ INDEX / INDICE

CODE	REF.NO.	Page
SP2209001	C -29-16	14
SP2213001	C -29-1	16
SP2214001	C -29-3	16
SP2215001	C -29-4	16
SP2216001	C -29-6	16
SP2217001	C -29-7	16
SP2218001	C -29-11	16
SP2219001	C -29-13	16
SP2220001	C -29-19	16
SP2221001	C -29-32	16
SP2222001	C -29-34	16
SP2224001	C -29-1	16
SP2225001	C -29-6	16
SP2226001	C -29-7	16
SP2227001	C -30	12
SP2228001	C -33	12
SP2229001	C -34	12
SP2230001	C -36	12
SP2231001	C -37	12
SP2232001	C -38	14
SP2240001	D -1	18
SP2245001	D -1-7	18
	D -64-8	20
SP2246001	D -1-8	18
	F -26-8	24
SP2247000	D -14	18
	D -65	20
SP2248000	D -17	18
SP2249001	D -20	18
SP2250001	D -21	18
	D -31	18
SP2251001	D -24	18
	D -34	18
	D -62	18
SP2252001	D -29	18
SP2253001	D -30	18
SP2254000	D -37	18
SP2255001	D -38	18
SP2256001	D -41	18
SP2257001	D -42	18
	D -59	18
SP2258001	D -44	18
SP2259001	D -46	18
SP2260001	D -48	18
SP2261001	D -50	18
SP2262001	D -51	18
SP2263001	D -52	18
	D -71	20
SP2264000	D -53	18
	D -56	18
	D -72	20
	D -75	20
SP2265001	D -55	18
	D -73	20
SP2266001	D -58	18
SP2267001	D -63	18
SP2268001	D -64	20
SP2269001	D -67	20
SP2273001	D -70	20
SP2275001	D -77	20
SP2276000	D -78	20
SP2277001	D -80	20
SP2278001	D -82	20

CODE	REF.NO.	Page
SP2279001	D -84	20
SP2282001	D -27	18
SP2300001	E -1	22
SP2301001	E -2	22
SP2302001	E -4	22
SP2305001	E -10	22
SP2306001	E -12	22
SP2310001	E -12-7	22
	F -26-7	24
SP2311001	E -22	22
SP2312001	E -24	22
SP2313001	E -25	22
SP2314001	E -26	22
SP2315001	E -27	22
SP2316001	E -29	22
SP2317001	E -31	22
SP2318001	E -32	22
SP2319001	E -34	22
SP2320001	E -36	22
SP2321001	E -40-1	22
	Z -19	32
SP2322001	E -40-2	22
SP2323001	E -42	22
SP2324001	E -43	22
SP2325001	E -46	22
SP2326001	E -5	22
SP2330001	F -1	24
SP2331001	F -2	24
SP2332001	F -4	24
SP2333001	F -6	24
SP2334001	F -8	24
SP2335001	F -10	24
SP2336001	F -12	24
SP2337001	F -14	24
SP2338001	F -15	24
SP2339001	F -17	24
SP2340001	F -17-1	24
SP2341001	F -17-2	24
	F -55-2	24
SP2342001	F -20	24
SP2343001	F -21	24
SP2344001	F -23	24
SP2345001	F -26	24
SP2350001	F -40	24
SP2351001	F -42	24
SP2352000	F -43	24
SP2353001	F -45	24
SP2354001	F -47	24
SP2355001	F -48	24
SP2356001	F -50	24
SP2357001	F -52	24
SP2358001	F -53	24
SP2359001	F -55	24
SP2360001	F -55-1	24
SP2362001	F -58	24
SP2363001	F -60	24
SP2364001	F -61	24
SP2365001	F -66	26
SP2366001	F -67	26
SP2380001	G -1	28
SP2381000	G -3	28
SP2382001	G -4	28
SP2383001	G -4-1	28

CODE	REF.NO.	Page
SP2384001	G -4-2	28
SP2385001	G -4-3	28
SP2386001	G -4-4	28
SP2387001	G -4-5	28
SP2389000	G -15	28
SP2390000	G -16	28
SP2391001	G -17	28
SP2392000	G -18	28
SP2393001	G -19	28
SP2394001	G -20	28
SP2395000	G -23	28
SP2396001	G -24	28
SP2397000	G -25	28
SP2398000	G -26	28
SP2399000	G -27	28
SP2400000	G -29	28
SP2401000	G -30	28
SP2402001	G -31	28
SP2403000	G -33	28
SP2404000	G -34	28
SP2405001	G -36	28
SP2406001	G -39	28
SP2407001	G -39-1	28
SP2408000	G -44	28
SP2409000	G -45	28
SP2410000	G -46	28
SP2411000	G -47	28
SP2412000	G -48	28
SP2420001	Z -27	32
SP2421001	Z -29	32
SP2422001	Z -30	32
SP2423001	Z -32	32
SP2424001	Z -33	32
SP2426001	H -2	30
SP2427001	H -4	30
SP2428001	H -6	30
SP2429001	H -7	30
SP2430001	H -8	30
SP2431001	H -8-1	30
SP2432000	H -9	30
SP2433001	H -12	30
SP2434001	H -12-2	30
	H -13-2	30
	H -14-2	30
SP2435001	H -12-3	30
SP2437001	H -12-5	30
	H -13-5	30
	H -14-5	30
SP2438001	H -13	30
SP2439001	H -13-3	30
SP2440001	H -14	30
SP2441001	H -14-3	30
SP2442001	H -15	30
SP2443001	H -16	30
SP2450001	Z -38	34
SP2451001	Z -42-1	34
SP2452001	Z -43	34
SP2453001	Z -46	34
SP2454001	Z -47	34
SP2455001	Z -49	34
SP2457000	Z -49-1	34
SP2458000	Z -50-1-33	36
	Z -50-2-33	38







/INDEX/VERZEICHNIS  
 OX/INDICE

CODE	REF.NO.	Page
259001	Z -42-2	34
260001	Z -60-15	34
261001	Z -60-16	34
2500001	a -1-1	40
2501001	a -1-1-1	40
2502001	a -1-1-2	40
2503001	a -1-1-4	40
	a -1-1-63	42
2504001	a -1-1-5	40
2505001	a -1-1-6	40
	a -1-1-11	40
2506001	a -1-1-8	40
2507001	a -1-1-10	40
2509001	a -1-1-13	40
2510001	a -1-1-15	40
2511001	a -1-1-16	40
	a -1-1-19	40
2512001	a -1-1-17	40
	a -1-1-20	40
	a -1-1-36	40
	a -1-1-79	42
	a -1-1-81	42
2513001	a -1-1-18	40
2514001	a -1-1-21	40
2515001	a -1-1-24	40
2516001	a -1-1-26	40
2517001	a -1-1-27	40
2518000	a -1-1-29	40
2519001	a -1-1-30	40
2520001	a -1-1-31	40
2521001	a -1-1-34	40
2523001	a -1-1-37	40
2524001	a -1-1-38	40
2525001	a -1-1-41	40
2526001	a -1-1-42	40
2527000	a -1-1-44	40
2528000	a -1-1-45	40
	a -1-1-68	42
2529001	a -1-1-46	40
2530001	a -1-1-48	40
2531001	a -1-1-51	42
2532001	a -1-1-52	42
2533001	a -1-1-54	42
	a -1-1-58	42
2534001	a -1-1-56	42
2536001	a -1-1-61	42
2538001	a -1-1-65	42
2539001	a -1-1-66	42
2540001	a -1-1-67	42
2542001	a -1-1-69	42
2543001	a -1-1-71	42
2544001	a -1-1-73	42
2545001	a -1-1-74	42
2546001	a -1-1-76	42
2547001	a -1-2	42
2549001	a -1-3	42
2550001	a -1-4	42
2551001	a -1-5-2	42
2552000	a -1-1-83	42
2553001	a -1-5	42
2554001	a -1-5-1	42
2555001	a -1	40
2556001	a -2-1	44

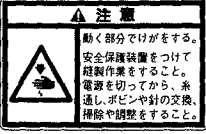
CODE	REF.NO.	Page
SP2557001	a -2-3	44
SP2558000	a -2-4	44
SP2559000	a -2-5	44
SP2560000	a -2-7	44
SP2561000	a -2-8	44
SP2562001	a -2-9	44
SP2563001	a -2-11	44
SP2564001	a -2-12	44
SP2565001	a -2-14	44
SP2566001	a -2-16	44
SP2567001	a -2-18	44
SP2568001	a -2-19	44
SP2569001	a -2-20	44
SP2570001	a -2-22	44
SP2571001	a -2-23	44
SP2573001	a -2	44
SP2574000	a -2-6	44
SP2980001	a -2	42
SP2981001	a -2-1	42
SP2982001	a -2-2	42
SP2983001	a -2	42
SP2984001	a -2	42
SP2985001	a -2	42
SP2986001	a -2	42

Wa. 警告ラベル / Warning labels / Warnschilder / Etiquettes d'avertissement  
/ Etiquetas de advertencia

警告ラベル / Warning labels	品名 / Name of parts	Size(mm)	Code
	<p>操作注意ラベル・和</p>	<p>40×64</p>	<p>S38350-001</p>
	<p>Label, operation Eng.</p>	<p>40×64</p>	<p>S38349-001</p>
	<p>矢印マーク Mark, arrow</p>	<p>10×30</p>	<p>S37058-001</p>
	<p>アースマーク Mark, grounding</p>	<p>φ 12</p>	<p>S37060-001</p>



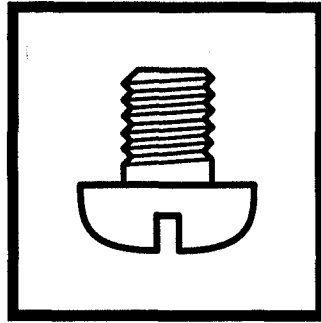

14-ツツク

PARTS BOOK

TEILEKATALOG

LIVRE DES PIÈCES

LIBRO DE REFERENCIA DE PIEZAS

ブラザー工業株式会社

BROTHER INDUSTRIES, LTD.

〒467-8562 名古屋市瑞穂区河岸一丁目1番1号 TEL(052)824-2392

Printed in Japan / Gedrukt in Japan / Imprimé au Japon / Impreso en Japon