

BROTHER BRUSHLESS DC GEARMOTORS

(12-48 VDC)

Technical Information

V SERIES

VG

Parallel Shaft
(Foot Mount)

Parallel Shaft
(Flange Mount)

VH

Right Angle Shaft
(Foot Mount)

VF3S

Right Angle Hollow Bore

■ Gearmotor Specifications	P. T2
■ Service Factors, Allowable Moment of Inertia	P. T8
■ Overhung Load (O.H.L.)	P. T9
■ Calculating Moment of Inertia	P. T10
■ Selection Procedure and Examples	P. T11
■ Output Shaft Dimension Diagrams	P. T12
■ Hollow Bore Safety Cap Dimension Diagrams	P. T16
■ Hollow Bore Attachment and Removal	P. T18
■ About VF3S Series Frame Numbers	P. T25
■ Cautions Regarding Use	P. T26
■ Options	P. T28

GEARMOTOR SPECIFICATIONS

Motor Specifications

Item \ Motor Power	50W		100W			200W		400W	
Motor	Brushless Motor								
Voltage (V)	12	24	12	24	48	24	48	24	48
Ambient Temperature (°C)	0~40°C								
Rated Current (A)	6.3	3.1	13.6	6.6	3.2	11.1	6.0	21.7	10.6
Wire Size (mm ²)	0.9 (AWG18)			2 (AWG14)					
Maximum Extended Length (m)	3								

● The rated current values in the table above are reference values for the motor unit only (gearhead removed). For gearmotor information, see p. T3.

Electromagnetic Brake Specifications

Item \ Motor Power	50W		100W			200W		400W	
Brake Type	Power-Off (Spring Close)								
Static Torque [Motor Shaft] (N•m)	0.20		0.57			0.95		1.76	
Excitation Voltage (±10%) (V)	12	24	12	24	48	24	48	24	48
Current Draw (20°C) (A)	0.44	0.25	0.65	0.36	0.17	0.58	0.28	0.58	0.31
Power Draw (20°C) (W)	5.3	6	7.8	8.6	8.3	13.9	13.2	13.9	15.1
Wire Size (mm ²)	0.5 (AWG20)								

Electromagnetic Brakes

Structure

50W

- ① Field
- ② Bolt for 6-Sided Hole
- ③ Friction Disc Pair
- ④ Setscrew for 6-Sided Hole
- ⑤ Brake Cover
- ⑥ Armature
- ⑦ Spring
- ⑧ Brake Cover Fastening Screw
- g: Gap

Note: After consistent use of the brake, gap "g" will grow to 0.5 mm or more. When this occurs the brake will not be able to disengage and adjustment will be necessary. Periodic inspection is recommended. The correct gap measurement is g = 0.2 mm.

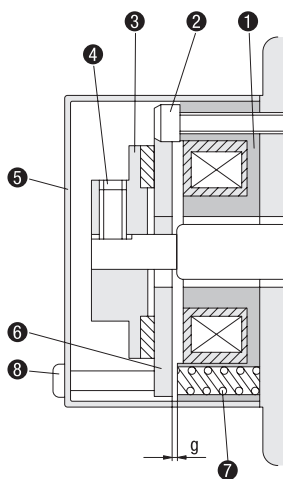

100·200·400W

- ① Field
- ② Armature
- ③ Outer Disc
- ④ Spring 1
- ⑤ Spring 2
- ⑥ Tooth Lock Washer Nut
- ⑦ Key
- ⑧ Bolt for 6-Sided Hole
- ⑨ Brake Cover
- ⑩ Brake Cover Fastening Screw
- g: Gap

Note: After consistent use of the brake, gap "g" will grow to 0.7 mm or more. When this occurs the brake will not be able to disengage and adjustment will be necessary. Periodic inspection is recommended. The correct gap measurement is g = 0.4 mm +/- 0.1 mm.

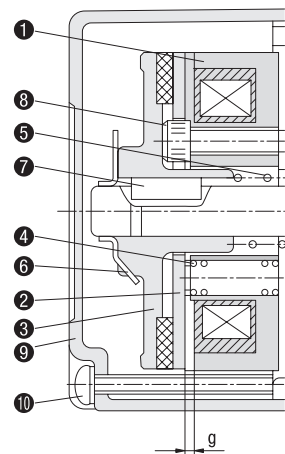

GEARMOTOR SPECIFICATIONS

Gearmotor Characteristics

The coefficient of rotation speed to load and the coefficient of current draw to load for gearmotor units are shown in these graphs. These characteristics are gearmotor unit characteristics. Customers may refer to these graphs when creating drivers. Standards for usage that conform to time ratings (5 sec. and 30 sec.) are shown, but we ask that our customers confirm this on their application.

Notes:

- The rotational speed in the graphs below corresponds to the motor shaft. Use the gear ratio to calculate the output rotational speed.
- In the graphs below, 100% corresponds to output allowable torque in the performance tables.
- When operating inside the limited duty range, there is the possibility that the life of the gearmotor will be reduced and that electromagnetic brakes will have reduced braking power. Contact our company for more details.

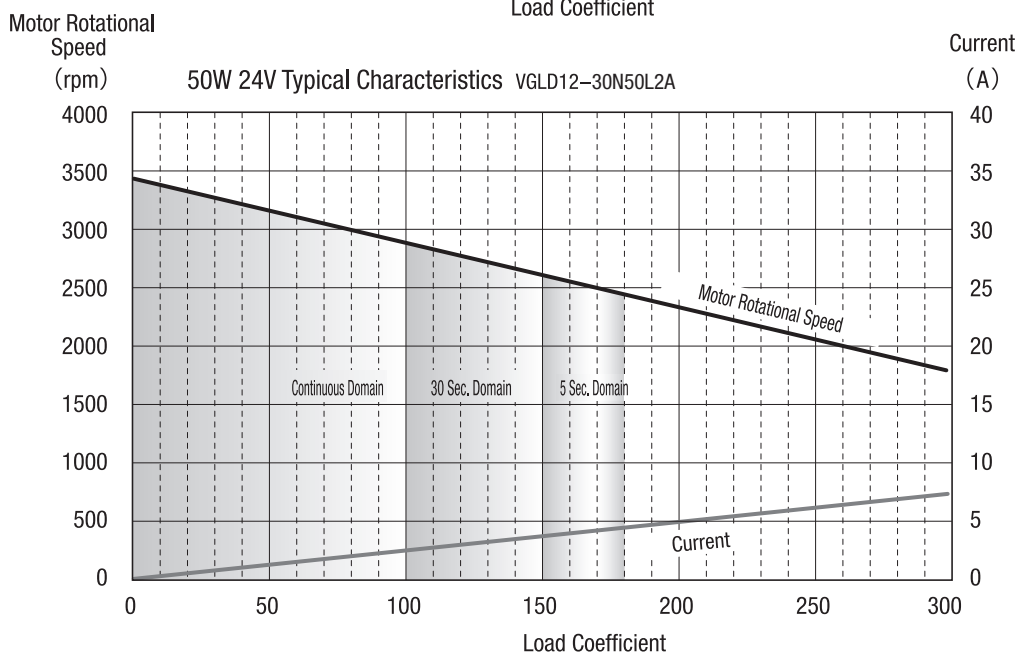
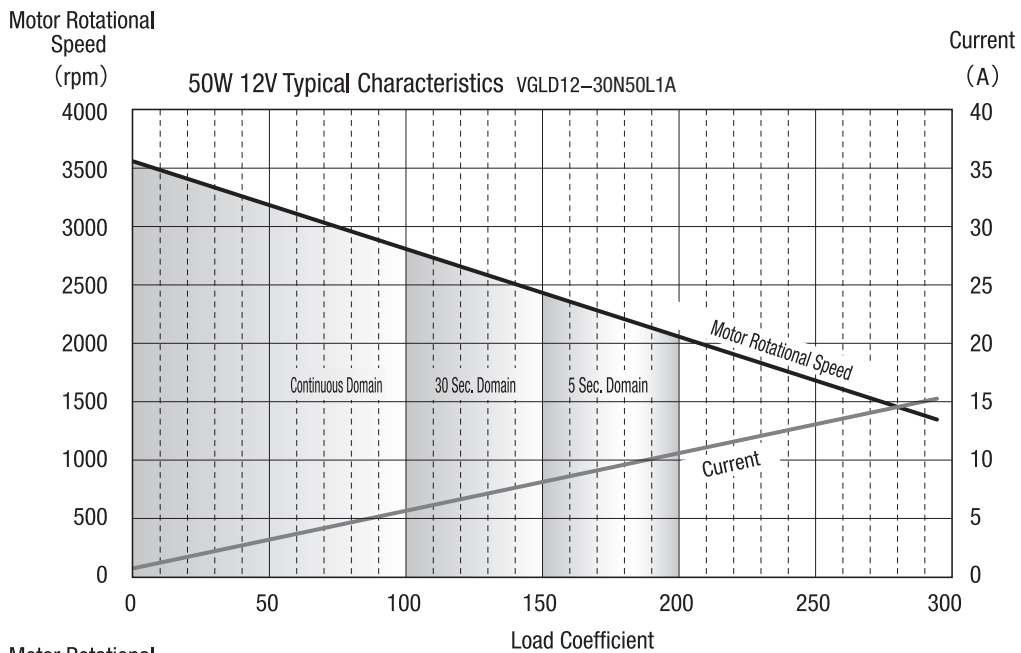

GEARMOTOR SPECIFICATIONS

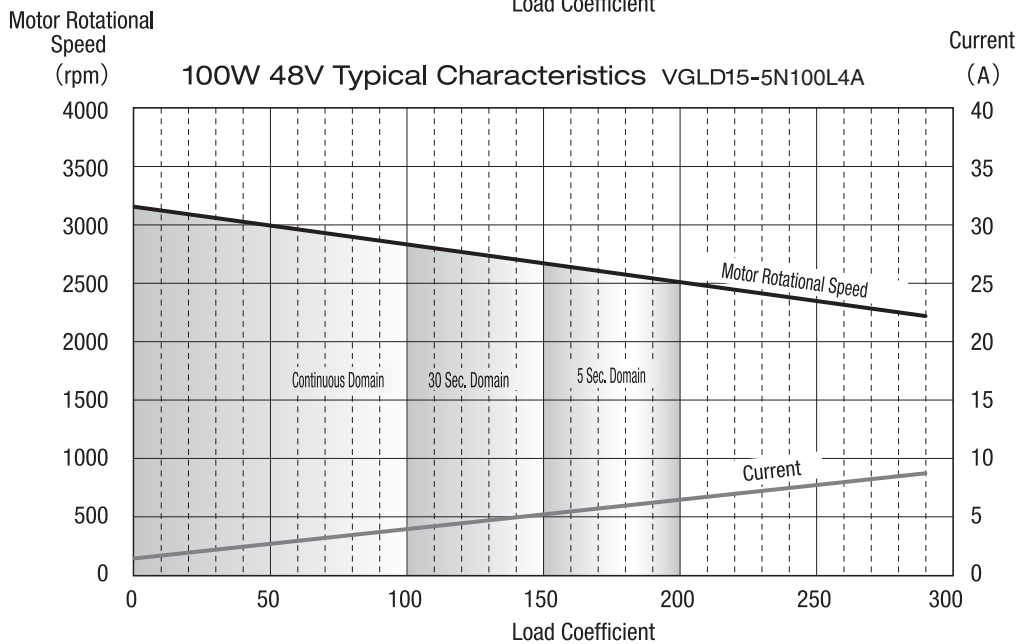
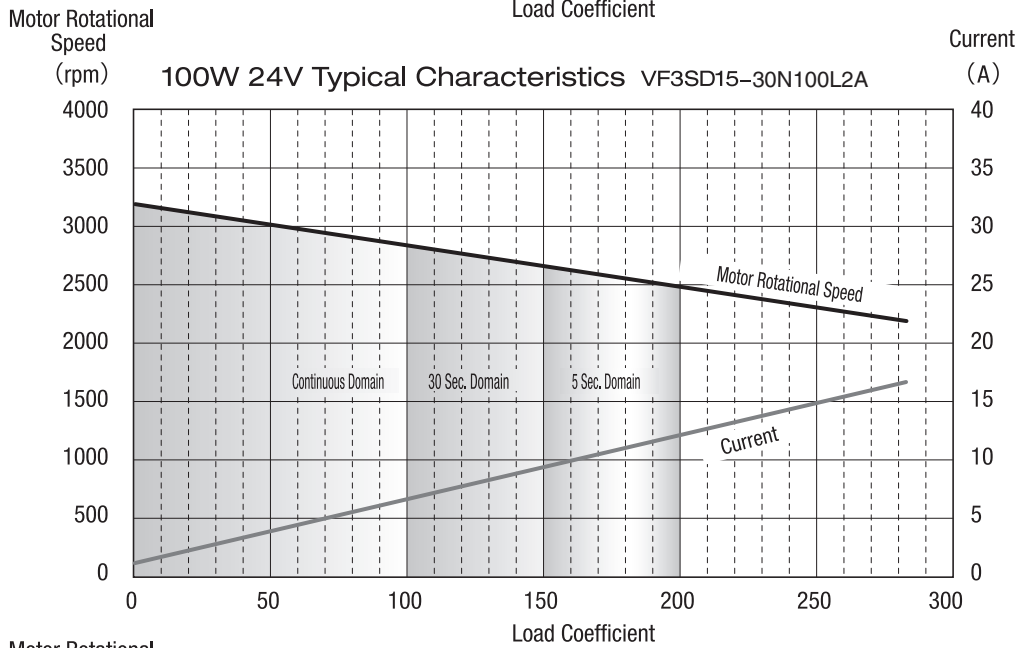
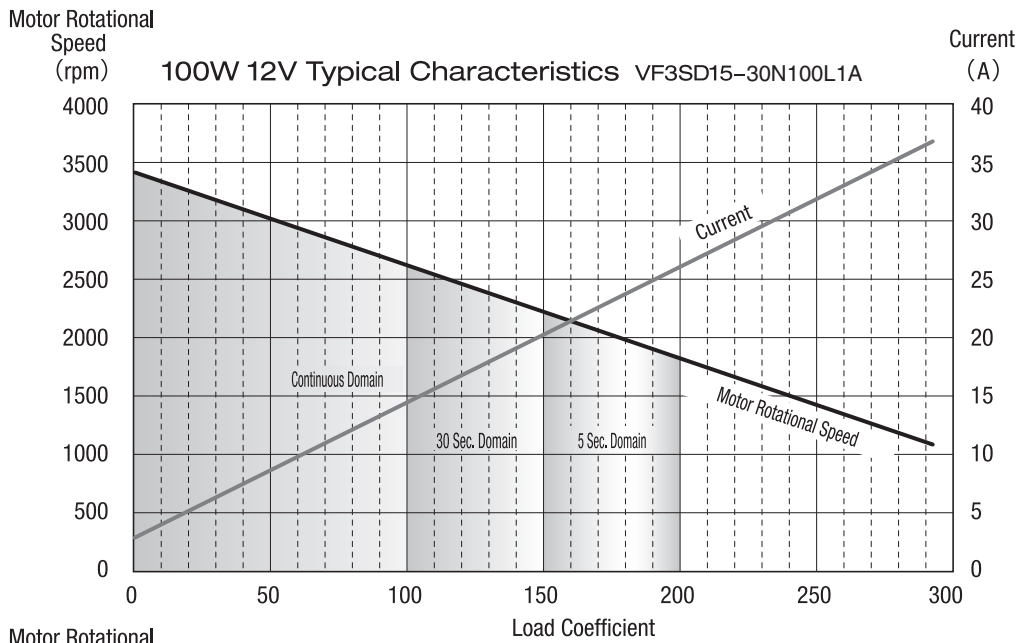

GEARMOTOR SPECIFICATIONS

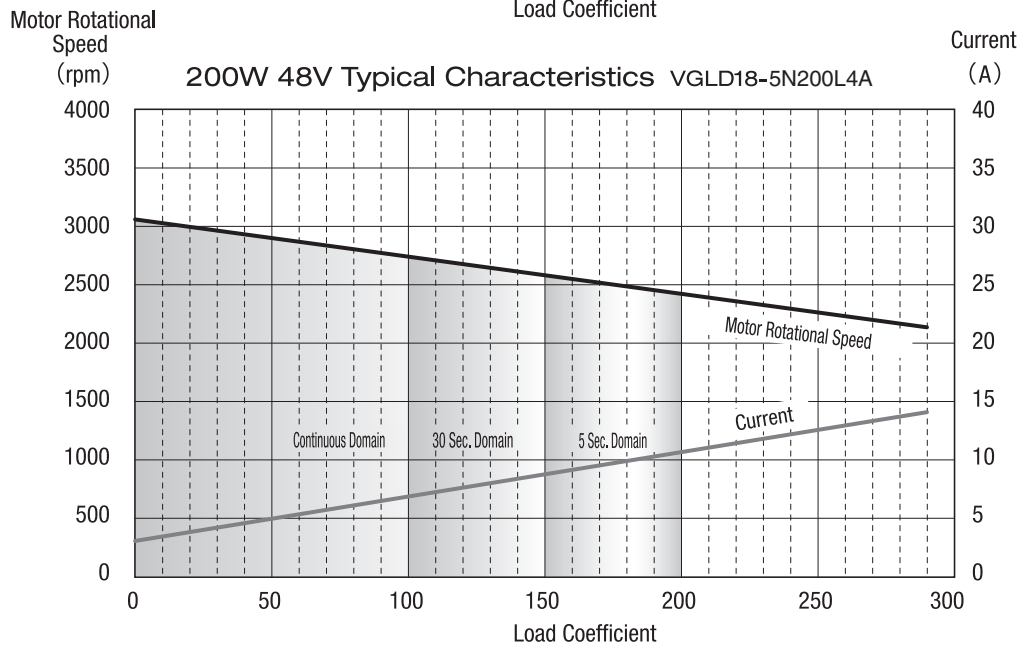
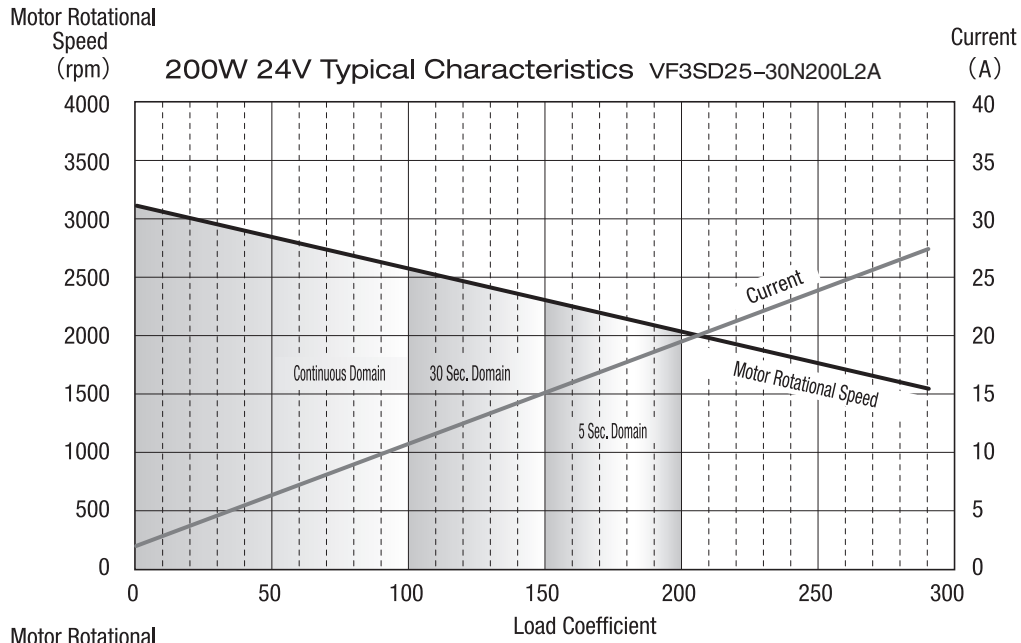

GEARMOTOR SPECIFICATIONS

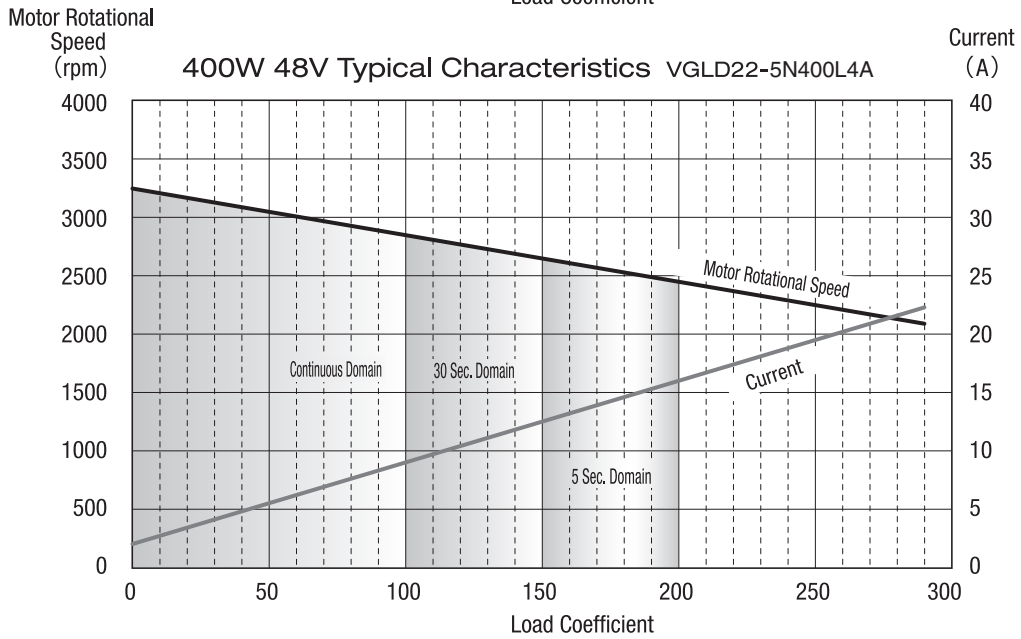
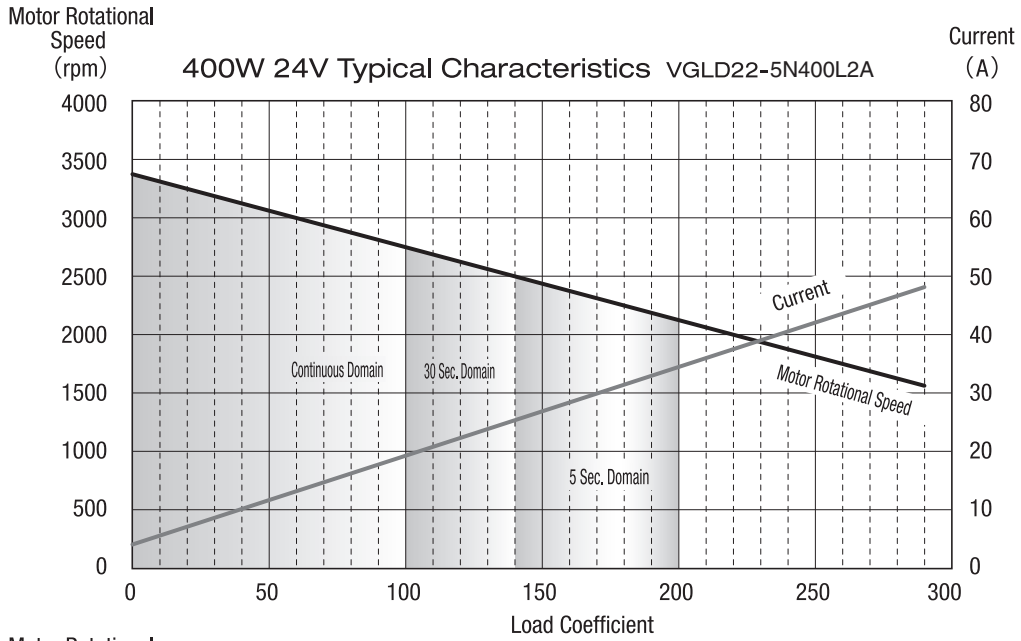

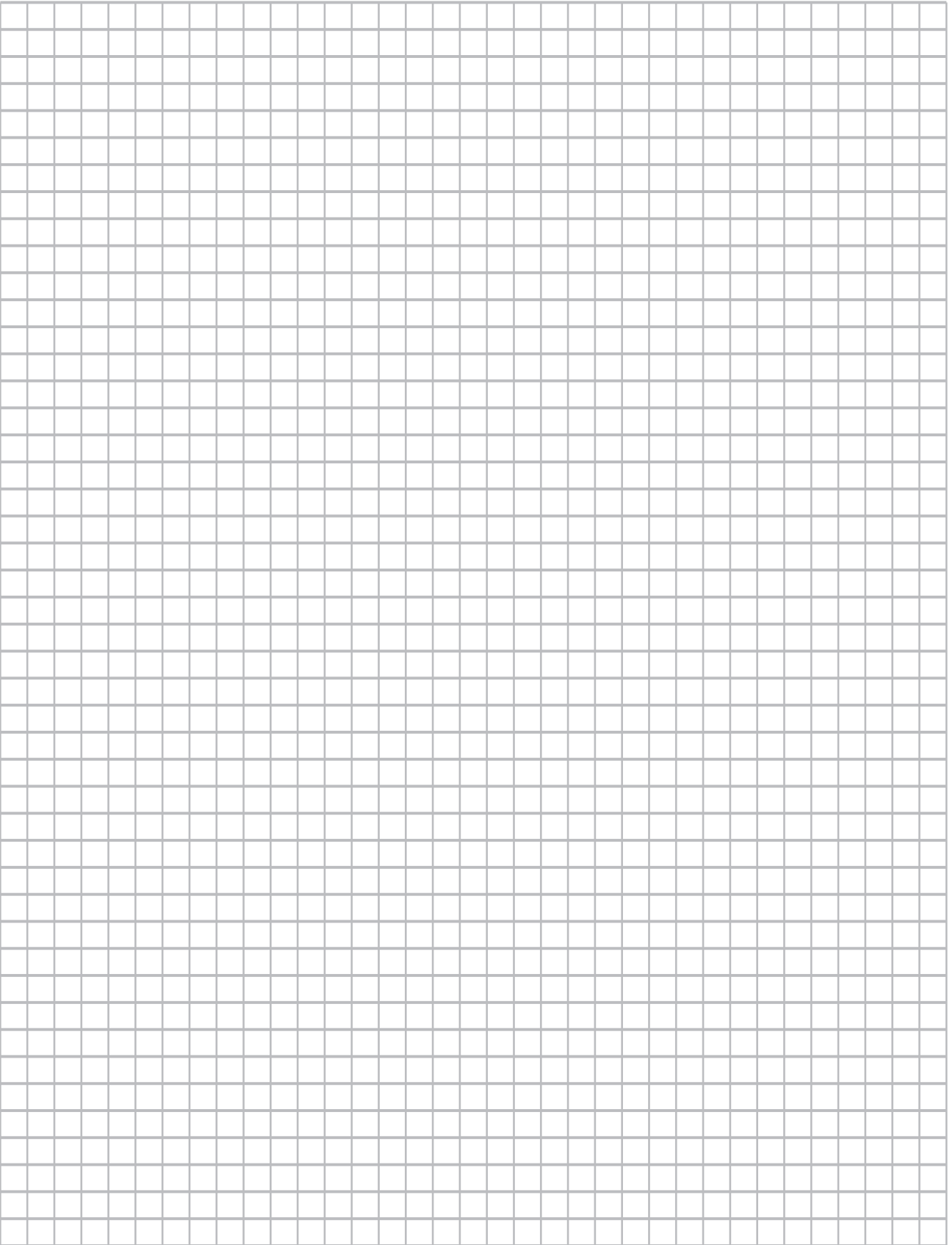

Service Factor (Sf)

Brother Brushless DC gearmotors are designed to run for 10 hours a day under uniform loads. When used under conditions that exceed those, load torque should be revised according to the service factors in the table below.

<Table 1>

Load Conditions	Service Factor (Sf)			Example of Use
	Run for 3 hours or less per day	Run for 3–10 hours per day	Run for over 10 hours per day	
Uniform Loads	1	1	1	Conveyor belts (standard load), screens, mixing machines (low-viscosity), water treatment (light load), machine tools (feed shafts), elevators, extruding machines and distilling machines
Moderate Shock Loads	1	1	1.25	Conveyor belts (non-standard loads and heavy loads), mixing machines (high-viscosity), vehicular machinery, water treatment (medium load), hoists (light loads), papermaking machines, feeders, food machinery, pumps, sugar refining machinery and textile machinery
Heavy Shock Loads	1	1.25	1.5	Hoists (heavy loads), hammer mills, metalworking machinery, crushers and tumblers

Allowable Moment of Inertia (J), by Motor Power

If operated intermittently with high-inertia loads, starting and stopping may cause sudden increases in torque, which can cause accidents without warning. The inertia of the application should be kept within the allowable value ranges given in the tables below with regard to linkage method and start-up frequency.

■ Allowable Moment of Inertia J by Motor Power

(Motor Shaft Equivalent)

<Table 2>

Motor Power	Allowable Moment of Inertia J (kg·m ²)
50W	0.0002
100W	0.00125
200W	0.0015
400W	0.0015

■ Allowable Moment of Inertia J According to Operating Conditions

— Correction Coefficients

<Table 3>

Linkage Method	Start-Up Frequency	Correction Coefficient
Direct Coupling (no slack)	Up to 70 times per day	1
	More than 70 times per day	1.5
By Chain (with slack)	Up to 70 times per day	2
	More than 70 times per day	3

Note: Motor Shaft Equivalent Moment of Inertia = Output Shaft Moment of Inertia J × (reduction ratio)²

Moment of Inertia (Jr) of the Gearmotor at the Motor Shaft, by Motor Power

<Table 4>

Motor Category	Motor				Brake-Motor			
	50	100	200	400	50	100	200	400
Moment of Inertia (kg·m ²)	0.11×10 ⁻⁴	0.65×10 ⁻⁴	1.3×10 ⁻⁴	2.5×10 ⁻⁴	0.12×10 ⁻⁴	0.77×10 ⁻⁴	1.4×10 ⁻⁴	3.0×10 ⁻⁴

Acceleration Torque and Braking Torque (Tp, Motor Shaft Equivalent), by Motor Power

<Table 5>

Motor Category	Motor				Brake-Motor			
	50	100	200	400	50	100	200	400
Acceleration Torque (N·m)	0.24	0.50	0.93	1.96	0.24	0.50	0.93	1.96
Braking Torque (N·m)	0.24	0.50	0.93	1.96	0.24	0.50	0.93	1.96

Note: These values are drive dependent and should thus be treated as reference values only.

Start and Stop Frequency

Both Gearmotors and Breakmotors have a recommended start and stop frequency of 30 times per minute. This value is dependent on the final application and is therefore subject to change.

Overhung Load (O.H.L.)

Overhung Load (O.H.L.): When the shaft acts on a suspended load, and the linkage between the reducer shaft and the application uses chains, belts, or gears, O.H.L. consideration is absolutely necessary.

$$O.H.L. = \frac{T_{LE} \times K_1 \times K_2}{R} \text{ (N) [kgf]}$$

}

T_{LE} : Equivalent output torque (N•m) applied to reducer shaft

R : Pitch radius (m) of sprockets, pulleys, gears, etc. attached to reducer shaft

K_1 : Coefficient according to linkage method <table 6>

K_2 : Coefficient according to load position <table 7>

●O.H.L. as determined by the above formula should be less than the allowable O.H.L. listed in the performance table.

■ Coefficient K₁ <Table 6>

Linkage Method	K ₁
Chain or Timing Belt	1.00
Gears	1.25
V-Belt	1.50

■ Coefficient K₂ <Table 7>

Load Position	K ₂
Base of the Shaft	0.75
Middle of the Shaft	1.00
Shaft End	1.50

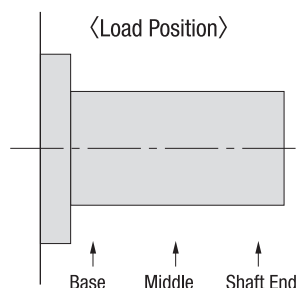

Hollow Shaft Overhung Loads (O.H.L.)

■ With a Flange Mount

(1) O.H.L. Load Position

The allowable O.H.L. load position is calculated to be 20 mm from the end of the output shaft.

(2)-1 O.H.L. Corrections When One End Can't Take a Pillow Block Bearing

If the length of the O.H.L. load position is more than 20 mm, it can be corrected using the following formula:

$$\text{operable O.H.L. (N)} = \frac{A+20}{A+L} \times \text{allowable O.H.L. (N)}$$

(Note) Refer to <table 8> for A.

<Table 8>

Frame No.	A (mm)
15	55
25	84.5
30	91
35	98

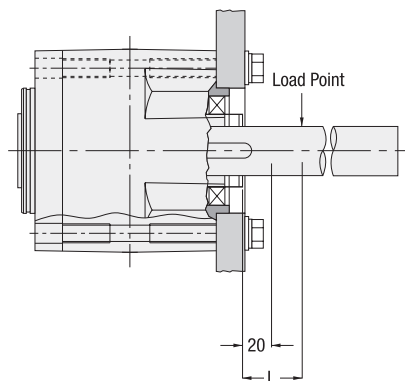

(2)-2 O.H.L. Corrections When One End Can Take a Pillow Block Bearing

Correct using the following formula:

$$\text{operable O.H.L. (N)} = \frac{S}{S-L} \times \text{allowable O.H.L. (N)}$$

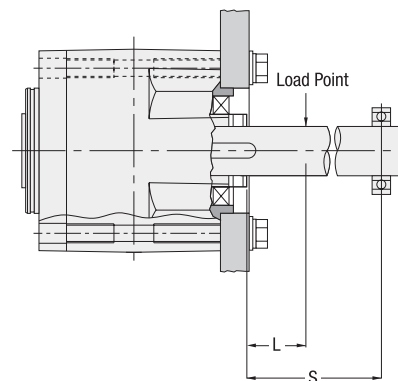

These diagrams depict model VF3S (right angle hollow bore)

How to Calculate Moment of Inertia

SI (metric system) moment of inertia $J(\text{kg} \cdot \text{m}^2)$ and gravitational metric system $GD^2(\text{kgf} \cdot \text{m}^2)$ are calculated as shown below.

$$J = \frac{GD^2}{4}$$

G : Weight (kgf)
 D : Diameter of Rotation (m)
 I : Moment of Inertia ($\text{kg} \cdot \text{m}^2$)

Moment of Inertia J for a Rotating Body

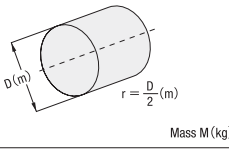
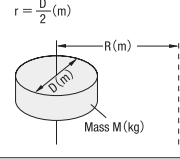
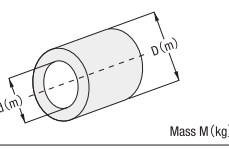
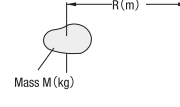
When the center of rotation and center of gravity are the same		When the center of rotation and center of gravity are not the same	
	SI Units		SI Units
	$J = \frac{1}{2}Mr^2$ $(\text{kg} \cdot \text{m}^2)$		$J = \frac{1}{2}Mr^2 + MR^2$ $(\text{kg} \cdot \text{m}^2)$
	$J = \frac{1}{2}M(r_1^2 + r_2^2)$ $(\text{kg} \cdot \text{m}^2)$		(in cases where size can be ignored) $J = MR^2$ $(\text{kg} \cdot \text{m}^2)$

Moment of Inertia J for Motion in a Straight Line

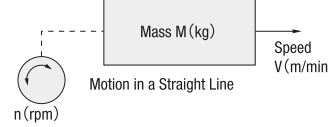
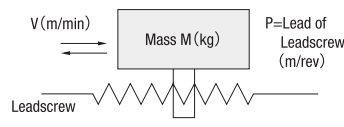
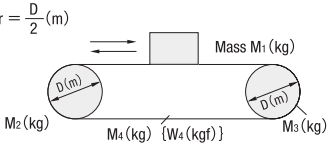
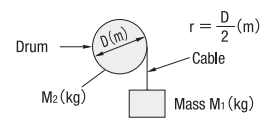
		SI Units
General Case		$J = \frac{1}{4}M \cdot \left(\frac{V}{\pi \cdot n}\right)^2$ $(\text{kg} \cdot \text{m}^2)$
Horizontal motion in a straight line (where the body is moved by a leadscrew)		$J = \frac{1}{4}M \cdot \left(\frac{P}{\pi}\right)^2$ $= \frac{1}{4}M \cdot \left(\frac{V}{\pi \cdot n}\right)^2$ $(\text{kg} \cdot \text{m}^2)$
Horizontal motion in a straight line (by a conveyor belt or similar)		$J = M_1r^2 + \frac{1}{2}M_2r^2$ $+ \frac{1}{2}M_3r^2 + M_4r^2$ $(\text{kg} \cdot \text{m}^2)$
Vertical motion in a straight line (by a crane, winch, or similar)		$J = M_1r^2 + \frac{1}{2}M_2r^2$ $(\text{kg} \cdot \text{m}^2)$

Calculating Moment of Inertia J with a Rotational Ratio

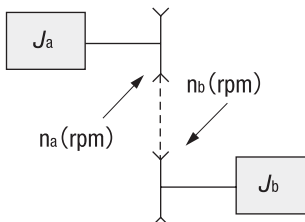

To calculate load moment of inertia J_b for shaft n_a :

$$J = J_a + \left(\frac{n_b}{n_a}\right)^2 \times J_b$$

Device Selection Process

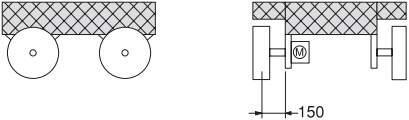
Use	Cart Motion (4 Wheels)
<p>Selection Conditions</p>	<p>Maximum Speed : 2 km/h Outer Tire Diameter : 200 mm Total Weight : 100 kg Vehicle Friction Coefficient : 0.1 O.H.L. Load Point : 150 mm from flange surface (see diagram below) Usage Frequency : 10+ hours per day, up to 70 starts per day</p> 
<p>Gear Ratio Determination</p>	<p>2 km/h = 33,333 mm/min Calculate shaft rotation speed at maximum speed. $33,333 \div (200 \times \pi) = 53.1 \text{ rpm}$ If the accompanying drive has a maximum speed of 2,500 RPM: $2,500 \div 53.1 = 47.1$ Since it's a variable-speed control motor, we'll choose a slightly lower speed ratio of 1/40 resulting in a speed range of 3.8-62.5 RPM.</p>
<p>Torque and Motor Power Examination</p>	<p>$100 \text{ kg} \times 0.1 \times (200 \text{ mm} \div 2 \div 1,000) \times Sf \times 9.8$ If we use a service factor (Sf) of 1.25, the above formula yields 12.25 Nm. (Note: refer to p. T16 regarding service factors.) With a reduction ratio of 1/40, a unit with an output shaft allowable torque of 12.25 Nm or more will require a motor output of at least 100W.</p>
<p>Motor Shaft Conversion Load Moment of Inertia Examination</p>	<p>$100 \text{ kg} \times (200 \text{ mm} \div 2 \div 1,000)^2 \times i^2 \times C$ If we use 1 for correction coefficient C and 1/40 for i, the above formula yields 0.000625 kgm². (Note: refer to p. T8 regarding moment of inertia.) On the moment of inertia table, the highest allowable value for 100W is 0.00125 kgm², so this is within the allowable range. (Note: refer to p. T8 regarding allowable moment of inertia.) (Note: the above calculations are simple and disregard factors such as vehicle and shaft moments of inertia.)</p>
<p>Overhung Load Examination</p>	<p>O.H.L. in accordance with load torque: $12.25 \times K1 \times K2 \div (200 \div 2 \div 1,000)$ If we use 1 for linkage coefficient K1 and 1 for load position coefficient K2, the above formula yields 122.5 N. (Note: refer to p. T9 regarding the linkage and load position coefficients.) Additionally, one-fourth of the cart's weight of 25 kg (245 N) rests on an axle. These two forces are applied at a 90° angle, so the composite force is 274 N. According to the performance table, allowable O.H.L. for a 100W, 1/40 hollow shaft unit is 830 N. In the case of a hollow shaft unit with flange mounts (so that it cannot take a pillow block bearing on one end), we have to correct the allowable O.H.L. (Note: refer to p. T9.) In this case, $(55 + 20) \div (55 + 150) \times 830 = 303$ Thus, because $303 > 274$, it is within the allowable range.</p>
<p>Model Selection Results</p>	<p>If we go with a brake-less, 24V power supply model, the model we choose will be VF3SC15-40N100L2A.</p>

OUTPUT SHAFT DIMENSION DIAGRAMS

VG(Parallel Shaft)

VGL(Foot Mount)

Frames 12-15 (50W)

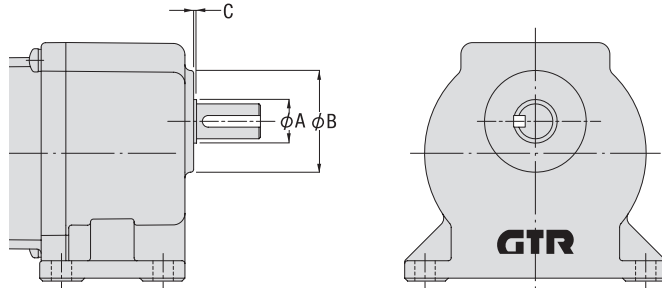

Frame No.	Dimension (mm)		
	A	B	C
12	15	35	1
15	17	40	1

Frame 15 (100W)

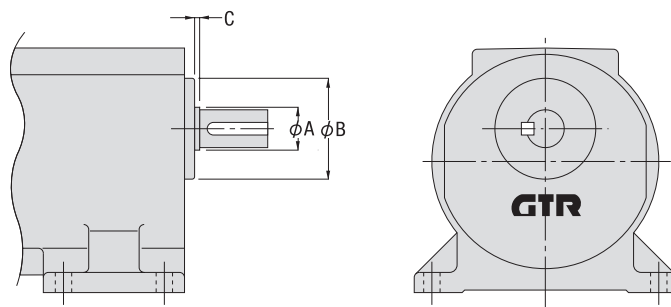

Frame No.	Dimension (mm)		
	A	B	C
15	17	40	2

Frames 18-32

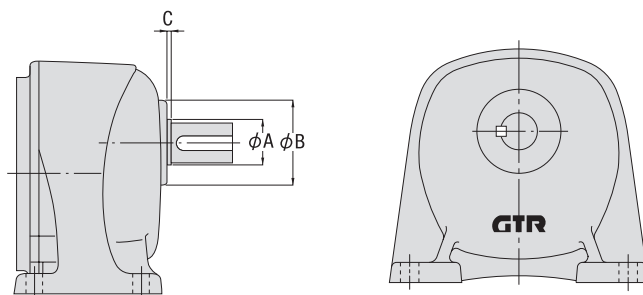

Frame No.	Dimension (mm)		
	A	B	C
18	20	43	2
22	24	50	2
28	30	60	2
32	34	68	3

OUTPUT SHAFT DIMENSION DIAGRAMS

VG(Parallel Shaft)

VGK(Flange Mount)

Frames 12-15 (50W)

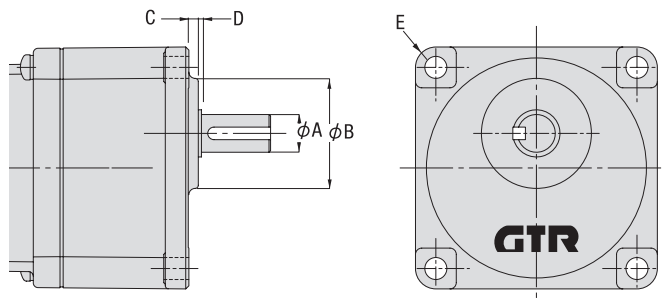

Dimension (mm)	A	B	C	D	E
Frame No. 12	15	35	3	1	R6.5
15	17	40	3	1	R7.5

(Note) Dimension B is not machined. Therefore, the corresponding hole should be enlarged by at least 0.5 mm more than the figure given.

Frame 15 (100W)

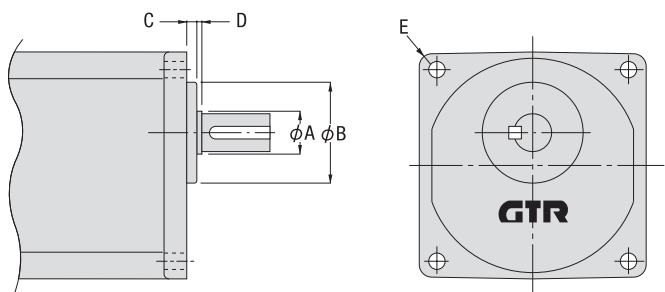

Dimension (mm)	A	B	C	D	E
Frame No. 15	17	40	4	2	R5

(Note) Dimension B is not machined. Therefore, the corresponding hole should be enlarged by at least 0.5 mm more than the figure given.

Frames 18-32

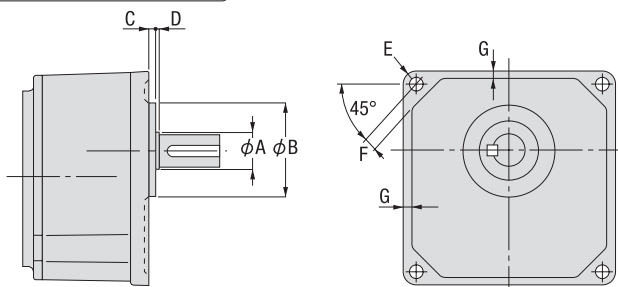

Dimension (mm)	A	B (h7)	Diameter Tolerance	C	D	E	F	G
Frame No. 18	20	50	+0.000/-0.025	4	2	R 9	9	5
22	24	60	+0.000/-0.030	5	2	R 8	9	5
28	30	80	+0.000/-0.030	5	2	R 11	11	7
32	34	88	+0.000/-0.035	5	3	R 13	13	8

OUTPUT SHAFT DIMENSION DIAGRAMS

VH(Right Angle Shaft)

VHL(Foot Mount)

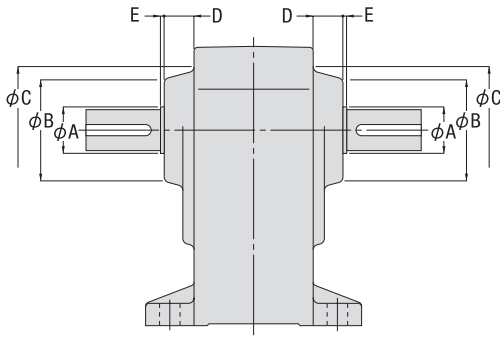

Frame No.	Dimension (mm)				
	A	B	C	D	E
22	25	55	63.5	16	2
28	30	67	76	16	2
32	35	78	88	17	3

VF3S(Right Angle Hollow Bore)

Frame 15

Frames 25–35

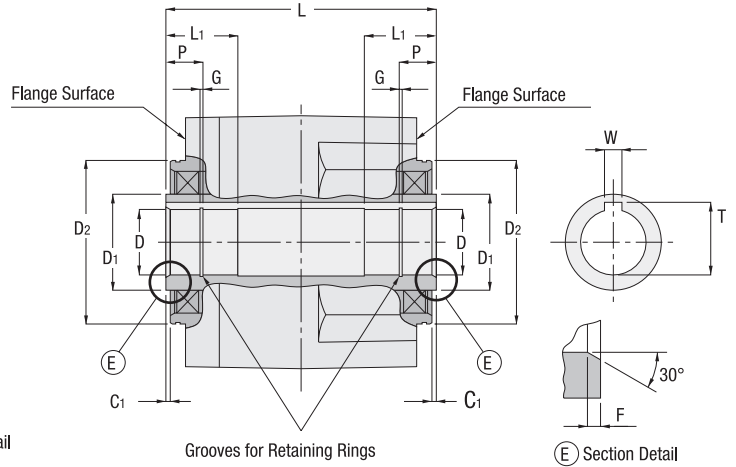
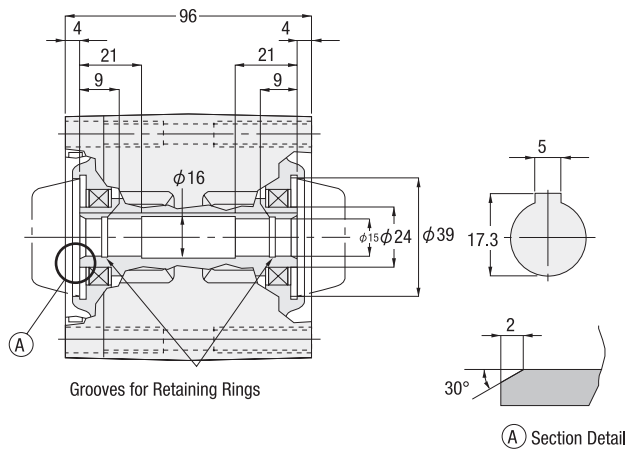

Detailed Dimension Chart for Hollow Shaft (mm)

Frame No.	D (H ₈)	D ₁	Diameter Tolerance	D ₂ (h ₇)	Diameter Tolerance	W	T	L	L ₁	P	C ₁	F	G
25	φ25	φ39	+0.033/-0.000	φ66	+0.000/-0.030	8	28.3	118	27	14	2	2	1.35
30	φ30	φ44	+0.039/-0.000	φ75	+0.000/-0.030	8	33.3	124	33	17	2	2	1.35
35	φ35	φ49	+0.039/-0.000	φ85	+0.000/-0.035	10	38.3	142	38	20	2	2	1.75

OUTPUT SHAFT DIMENSION DIAGRAMS

Detailed Dimensions for Output Shaft

- VG (Parallel Shaft)
- VH (Right Angle Shaft)

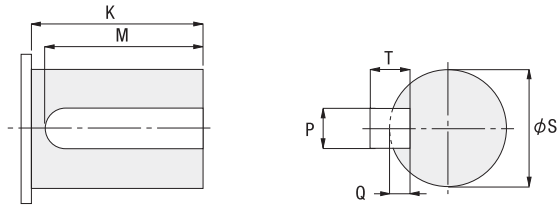

Dimension (mm) Frame No.	K	M	S (h ₆)	Key Part				
				P (h ₉)		T		Q
12	22	20	12	4	0 -0.030	4	0 -0.030	2.5
15	27	24	15	5		5		3
18	30	27	18	6		6		3.5
22	40	35	22	0 -0.013	8	7	0 -0.090	4
28	45	40	28					8
32	55	50	32	0 -0.016	10	8		

VF3S(Right Angle Hollow Bore)

Frame 15

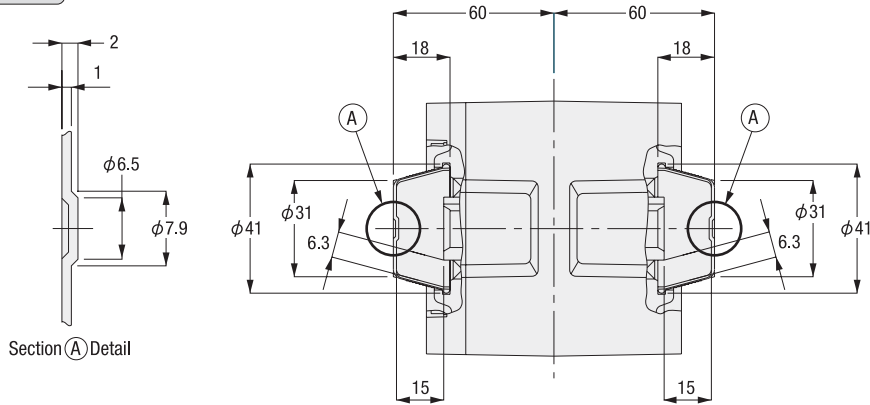

Frames 25–35

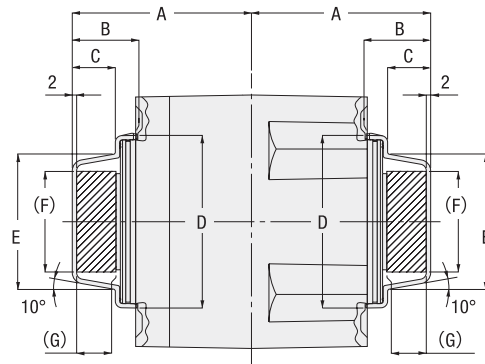

The shaded area is hollow. ()

Frame No.	A	B	C	D	E	F	G
25	79	29.5	19.7	φ70	φ53	φ37.5	18
30	82	19.5	19.7	φ79	φ62	φ46.5	18
35	95	33.5	23.7	φ89	φ72	φ55	22

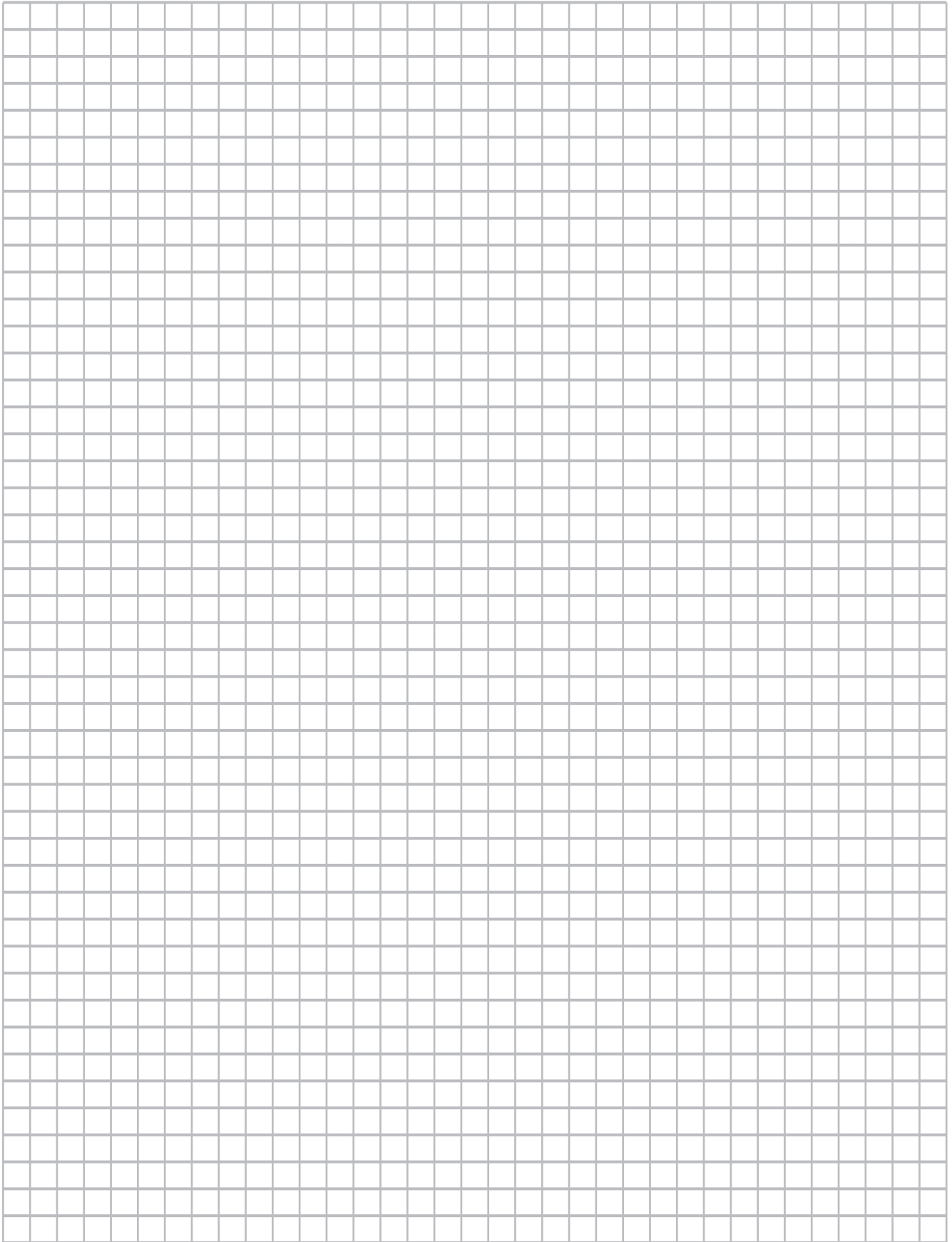

HOLLOW BORE ATTACHMENT AND REMOVAL

Attaching the Hollow Bore of the Reducer to the Drive Shaft

- ① Coat the drive shaft surface and bore surface with a lubricant (molybdenum disulfide) suitable to the atmosphere in which they are used and connect the reducer to the drive shaft.
- ② When used with uniform loads, a drive shaft tolerance of $h7$ is recommended. Additionally, when dealing with impact loads or large radial loads, make sure they fit each other tightly. The tolerance of the interior surface of the hollow bore is designed to be $H8$.
- ③ If the shafts are a tight fit, use a plastic hammer on the end of the hollow bore to insert it. When doing so, be sure not to hit the casing. If you make a jig like the one in the diagram below, drive shaft insertion will be easier.

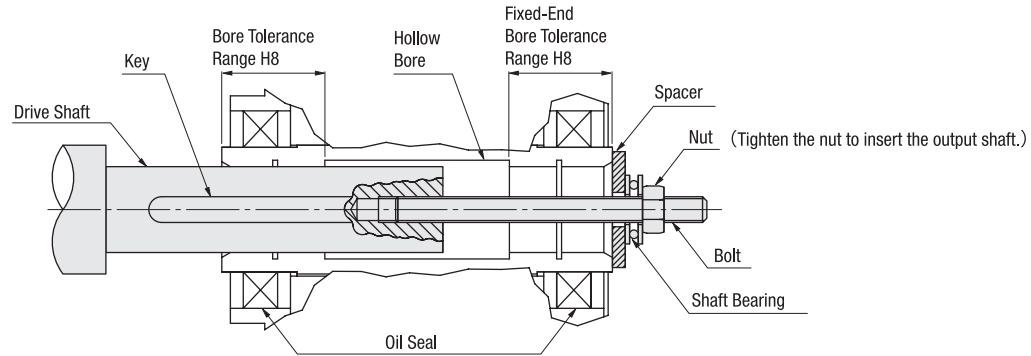

Figure 1

(Customers need to provide their own spacers, nuts, bolts, keys and shaft bearings.)

- ④ For the length of the turn-stop key for the drive shaft, tolerance range $H8$ for the bore on the fixed side is recommended. (The dimension for bore tolerance $H8$ corresponds to L_1 of the Detailed Dimension Chart for the Hollow Bore on p. T14.)
- ⑤ It is recommended that axial runout for the shaft be 0.05 mm or less at the shaft end. If major wobbling occurs during operation, it may have a negative effect on the reducer.

Connecting the Reducer to the Drive Shaft

- ① When there are steps on the drive shaft

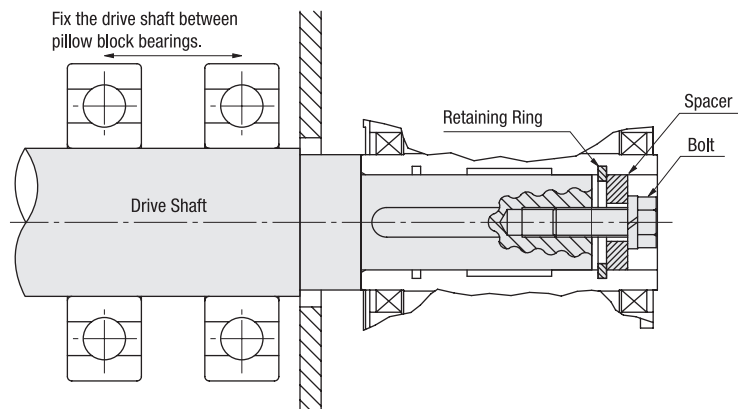

Figure 2: Attachment Using a Spacer and Retaining Ring

(Customers need to provide their own spacers, bolts, and retaining rings.)

(Note) Be careful when tightening the bolt, as tightening it too much can distort the shape of the retaining ring.

HOLLOW BORE ATTACHMENT AND REMOVAL

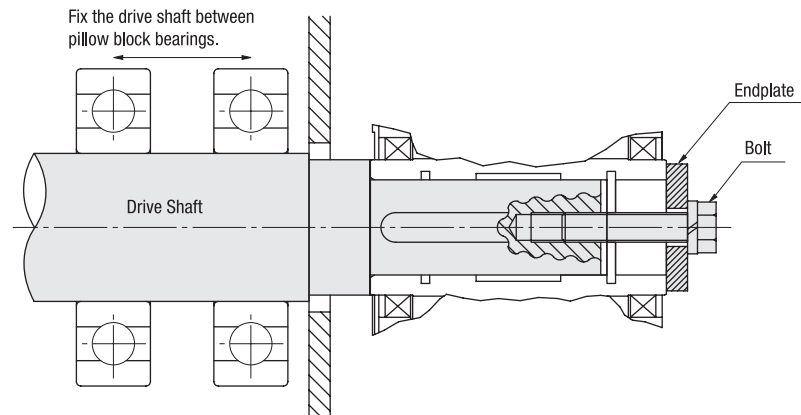

Figure 3: Attachment Using an Endplate
(Customers need to provide their own endplates and bolts.)

② When there are no steps on the drive shaft

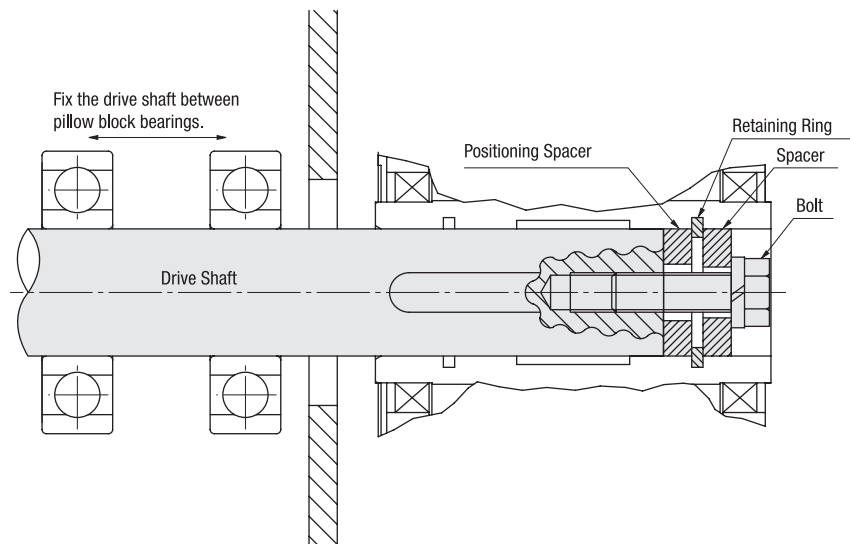
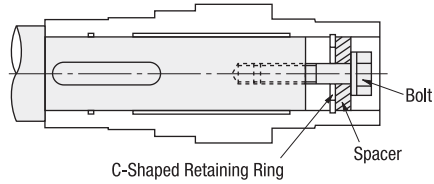

Figure 4: Attachment Using a Spacer and Retaining Ring
(Customers need to provide their own spacers, positioning spacers, bolts, and retaining rings.)

(Note) Make sure there is a gap between the outer diameter of the spacer and the bore diameter of the hollow bore. If the fit is too tight and the outer diameter of the spacer is inaccurate, burring and axial runout of the drive shaft and hollow bore can result. The positioning spacer is used to position the reducer. It is not required if you know the length of the drive shaft in advance. In addition, attaching the positioning spacer allows for smooth removal from the hollow bore. (Refer to Fig. 5, p. T20 for more on removal from the hollow bore.)

HOLLOW BORE ATTACHMENT AND REMOVAL

Recommended Sizes for the Fixing Elements of the Drive Shaft



Recommended Sizes for the Fixing Elements of the Drive Shaft (mm)

	Bolt Size	Spacer Dimensions			C-Shaped Retaining Ring for Holes
		Outer Diameter	Inner Diameter	Width	
VF3S15	M6	φ 14.5	φ 7	3	15
VF3S25	M6	φ 24.5	φ 7	4	25
VF3S30	M8	φ 29.5	φ 9	5	30
VF3S35	M10	φ 34.5	φ 11	5	35

Drive Shaft Length

Make sure the drive shaft reaches both ends of L1. (See figure at right.) However, look at the dimension leeway for spacers in the section titled "Removal from the Hollow Bore." For more details, refer to the detailed dimension charts for hollow bores and output shafts on p. T14.

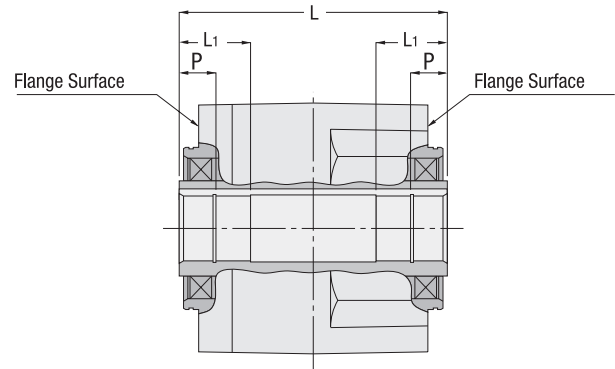

This diagram shows model VF3S (right angle hollow bore).

Drive Shaft Key Length

The length of the key should be at least 1.5 times the width of the hollow bore. Additionally, the key is inserted in such a position that at least half its length is in L1. (See figure at right.) For more details, refer to the detailed dimension charts for hollow bores and output shafts on p. T14.

Removal from the Hollow Bore

Make sure there is room to spare between the casing and the hollow bore. If you make and use a jig like the one below, drive shaft removal will be easier.

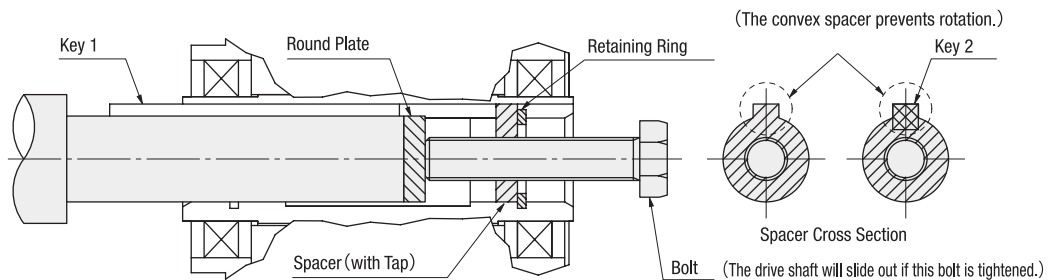

Figure 5

(Customers need to provide their own spacers, round plates, bolts and retaining ring keys.)

HOLLOW BORE ATTACHMENT AND REMOVAL

How to Install the Reducer

The Advantages and Disadvantages of Flange and Torque Arm Installation

	Advantages	Disadvantages
Flange Installation	<ul style="list-style-type: none"> • Can be installed directly on the device. • Saves space. 	<ul style="list-style-type: none"> • Centering with the application is required.
Torque Arm Installation	<ul style="list-style-type: none"> • Makes centering with the application easy. • Fastening to the application only requires one detent. 	<ul style="list-style-type: none"> • Requires a torque arm. • Requires space for installing a torque arm.

Hollow Bore and Flange Installation

When the hollow bore is installed directly to the flange of an application, it can cause motor burn-out or bearing damage if it is off-center, so be sure to center it properly. There is an installation guide, as shown in the diagram at right. The dimension tolerance for ϕA for the installation guide is h7 in the case of VF3S. The installation bolts are installed as shown in the diagram at right. Four bolts should be used.

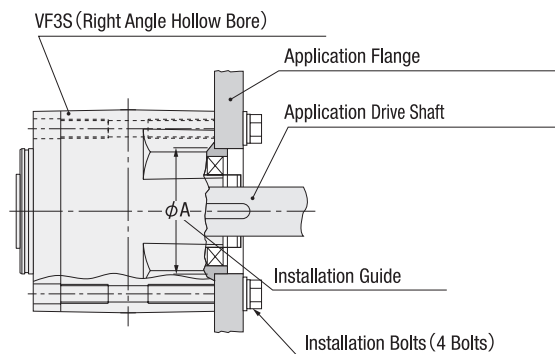

Detailed Diagram of Tapped Holes for VF3-Type Flange Mount Installation (Standard Specifications)

Right Angle Hollow Bore

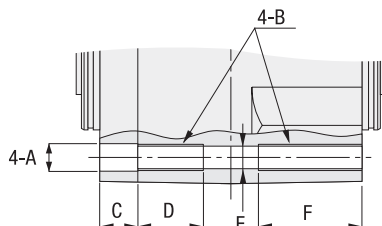

Frame No.	Reduction Ratio	Motor Power	A	B	C	D	E	F
15	1/10~1/160	0.1 kW	$\phi 10.5$	M10×P1.5	13	25	$\phi 8.6$	38
25	1/10~1/60	0.2 kW	$\phi 10.5$	M10×P1.5	14.5	25	$\phi 8.6$	39.5
30	1/10~1/60	0.4 kW	$\phi 10.5$	M10×P1.5	15.5	25	$\phi 8.6$	40.5
	1/80~1/240	0.2 kW	$\phi 12.5$	M12×P1.75	15.5	30	$\phi 10.6$	45.5
35	1/5~1/60	0.75 kW	$\phi 12.5$	M12×P1.75	18	30	$\phi 10.6$	48
	1/80~1/240	0.4 kW	$\phi 16.5$	M16×P2	18	40	$\phi 14$	58

(Note) When attaching the mounting bolts, it is recommended to have the engagement of the bolt with thread D or F be at least two times the screw size (bolt diameter).
(i.e. For an M10, 20 mm or more of thread engagement with D or F is recommended.)

Fastening the Reducer and Torque Arm

- 1 Because the torque arm sustains a reactive force from rotation, consideration needs to be given to impact loads particularly during startup and braking, and bolts and plates that are sufficiently strong must be used. It's best to use an optional torque arm. (See p. T23.)
- 2 To install the torque arm and reducer, fasten them using spring washers and flat washers with the installation bolts.

Bolt Size and Tightening Torque

Bolt Size	Tightening Torque N•m {kgf•m}
M8	13 { 1.3 }
M10	25 { 2.6 }
M12	44 { 4.5 }
M14	69 { 7.0 }
M16	108 { 11 }

How to Install the Torque Arm Detent

1 Oscillating Movement

Fasten the torque arm detent so there is no looseness or wobble. When doing this, center the detent hole with that of the application to make sure that no radial load (suspension load) is applied against the drive shaft and hollow shaft of the reducer. (See Fig. 6)

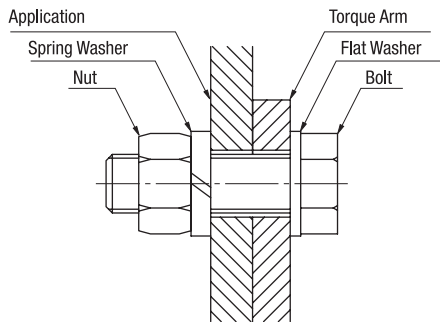
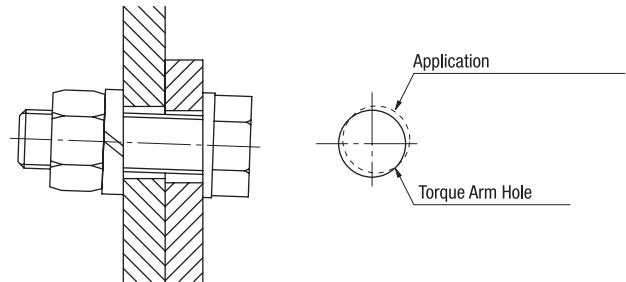

Figure 6: Fastening the Detent



Unnecessary force applied to the drive shaft and hollow bore can result in defects.

Bad Example

(Note) If looseness develops due to oscillating movement or start and stop frequency, start-up impact will be borne by the torque arm, causing the installation bolt to loosen, which can result in defects.

2 Unidirectional Movement

When start-up torque is not frequently applied, the torque arm can be used without a detent. However, it is still necessary to fasten the drive shaft to the reducer. Refer to figures 2–4 on pages T18–T19.

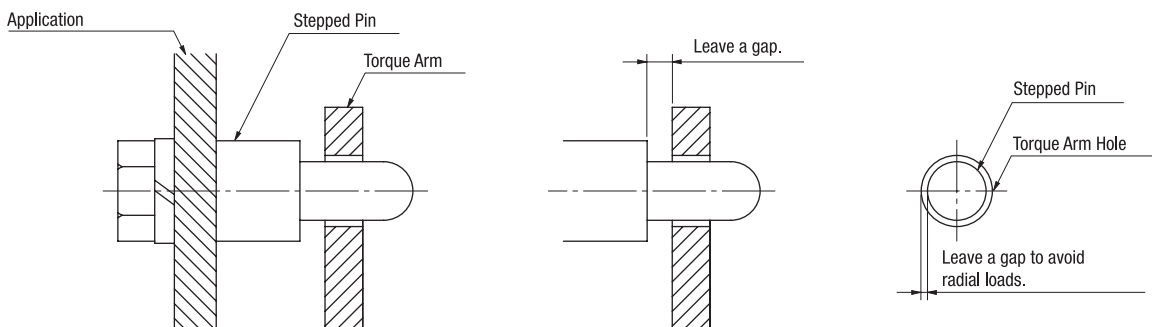
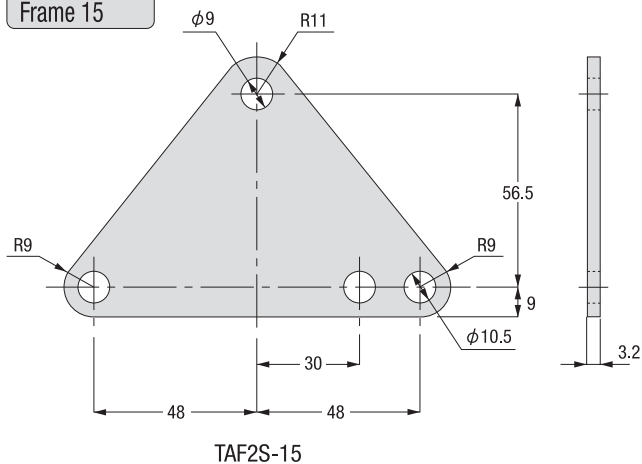

Figure 7: Example of Stepped Pin Usage

Torque Arm (Option)

Frame 15



TAF2S-15

Frames 25-35

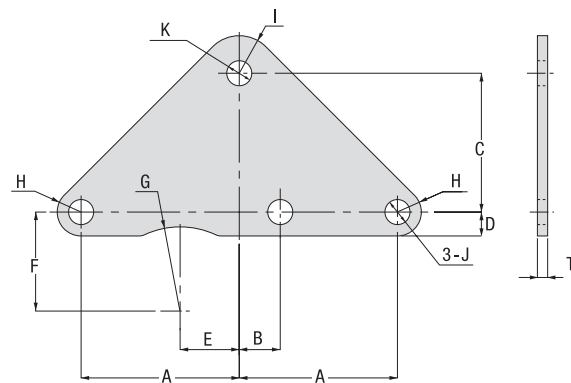

● Dimensions (mm)

Corresponding Frame No.	Part Number	Motor Power	Corresponding Reduction Ratio	A	B	C	D	E	F	G	H	I	J	K	T
25	TAF3S-25-2	200W	1/10~1/60	60	27	61	10.5	16.5	43.5	R37	R10.5	R15	φ11	φ9	3.2
30	TAF3S-30-2	400W	1/10~1/60	69.5	26.5	70	10.5	21.5	48	R41.5	R10.5	R15	φ11	φ11	4.5
	TAF3S-30-3	200W	1/80~1/240	78	14	70	12	32	46	R41.5	R12	R16.5	φ13.5	φ13.5	6
35	TAF3S-35-3	400W	1/80~1/240	97	11	94	15	43	54	R46.5	R15	R22.5	φ17.5	φ17.5	9

● Specifications

Corresponding Frame No.	Part Number	Motor Power	Corresponding Reduction Ratio	Weight (kg)	Material	Surface Treatment	Color
15	TAF2S-15	100W	1/10~1/160	0.1	SS41	Trivalent Chromate	White
25	TAF3S-25-2	200W	1/10~1/60	0.2	SS400		Surface Treatment Color (White)
30	TAF3S-30-2	400W	1/10~1/60	0.3			
	TAF3S-30-3	200W	1/80~1/240	0.4			
35	TAF3S-35-3	400W	1/80~1/240	1.2			

For delivery times, prices, and other details regarding torque arms, contact our sales office.

VF3S TORQUE ARM

Torque Arm Design

For customers wishing to make their own torque arms: if the torque arm is to be used as shown in Fig. 8, gap “r” between the output shaft center and the detent should be:

SI Units

$$r(\text{mm}) \geq \frac{\text{load torque (N} \cdot \text{m)} \times 1000}{\text{allowable O.H.L (N)} - 9.8 \times \text{reducer weight (kg)}}$$

Gravitational Metric System Units

$$r(\text{mm}) \geq \frac{\text{load torque (kgf} \cdot \text{m)} \times 1000}{\text{allowable O.H.L (kgf)} - \text{reducer weight (kgf)}}$$

If the torque arm is to be used as shown in Fig. 9, gap “r” between the output shaft center and the detent should be:

SI Units

$$r(\text{mm}) \geq \frac{\text{load torque (N} \cdot \text{m)} \times (A+M) \times 1000}{\{ \text{allowable O.H.L (N)} - 9.8 \times \text{reducer weight (kg)} \} \times (A+20)}$$

Gravitational Metric System Units

$$r(\text{mm}) \geq \frac{\text{load torque (kgf} \cdot \text{m)} \times (A+M) \times 1000}{\{ \text{allowable O.H.L (kgf)} - \text{reducer weight (kgf)} \} \times (A+20)}$$

(Note) Refer to the table below for A.

Frame No.	A (mm)
15	55
25	84.5
30	91
35	98

<Figure 8>

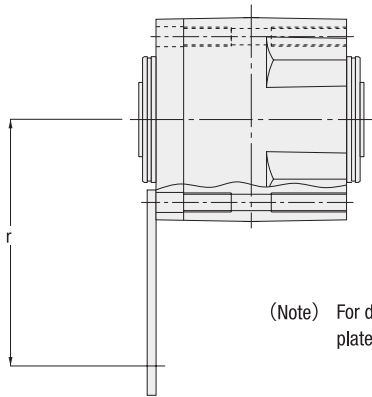

<Figure 9>

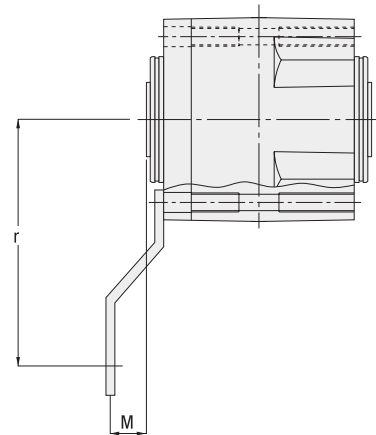

VF3S FRAME NUMBERS

VF3S Reducers include two different model formats with the same frame numbers.

1/5~1/60 2-Stage Reduction

1/80~1/240 3-Stage Reduction

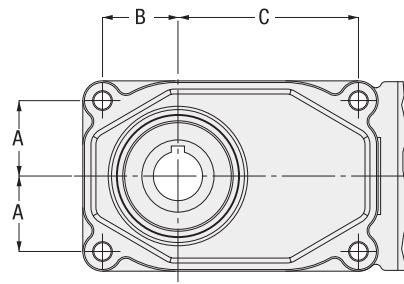
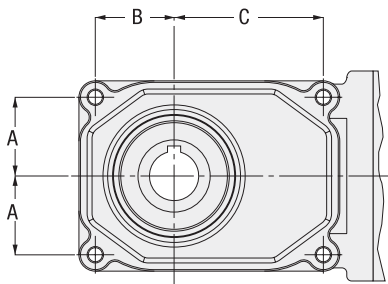

Frame No.	Reduction Ratio	Motor Power	A	B	C
25	1/10~1/60	200W	43.5	43.5	76.5
30	1/5~1/60	400W	48	48	91
	1/80~1/240	200W	46	46	110
35	1/80~1/240	400W	54	54	140

(Notes) 1. Frame 15 is the same for all reduction ratios.

VF3S Reducers have tapped holes (standard specifications) for flange mount installation. For more details, refer to p. T21.

CAUTIONS REGARDING USE

Installation Environment

Ambient Temperature	0°C–40°C
Ambient Humidity	85% or less
Altitude	1,000 m or lower
Environment	No corrosive gasses, flammable gasses or steam. Environment should be dust-free with good ventilation.
Installation Location	Indoors

Installation Surface

Devices with foot mounts or flange mounts should be fastened to a steady, flat, machine-processed surface using four bolts. The evenness of the surface should not vary by more than 0.3 mm. When mounting on a right angle hollow bore, refer to p. T21.

Installation Orientation

All models use grease lubricant, so there are no restrictions on installation orientation.

Installation Method

- ① An H7 fit is recommended for couplings, sprockets, pulleys and gears that connect to the reducer shaft.
- ② When making a direct link, make sure the reducer shaft and the application's shaft are aligned to be perfectly centered with each other.
- ③ To ensure that the reducer and application's shafts are both parallel when attaching chains and gears, position the device so that the line connecting the center of both gears is at a right angle to the shafts.
- ④ When connecting a coupling or the application to the output shaft, do not subject it to hard impacts using a hammer or similar tool. If the bearing is damaged, noisy operation and vibrations may result, causing further damage.

Cautions Regarding Operation

- ① Be sure only to operate the motor when load torque and moment of inertia J {GD²} · 0.H.L. fall within allowable parameters.
- ② Make sure to stop the motor completely before switching directions to avoid damage to the motor and machine.
- ③ The motor's built-in sensor should not be subjected to voltage tests of 12 volts or more.
- ④ The surface temperature of the motor should not exceed 90°C.

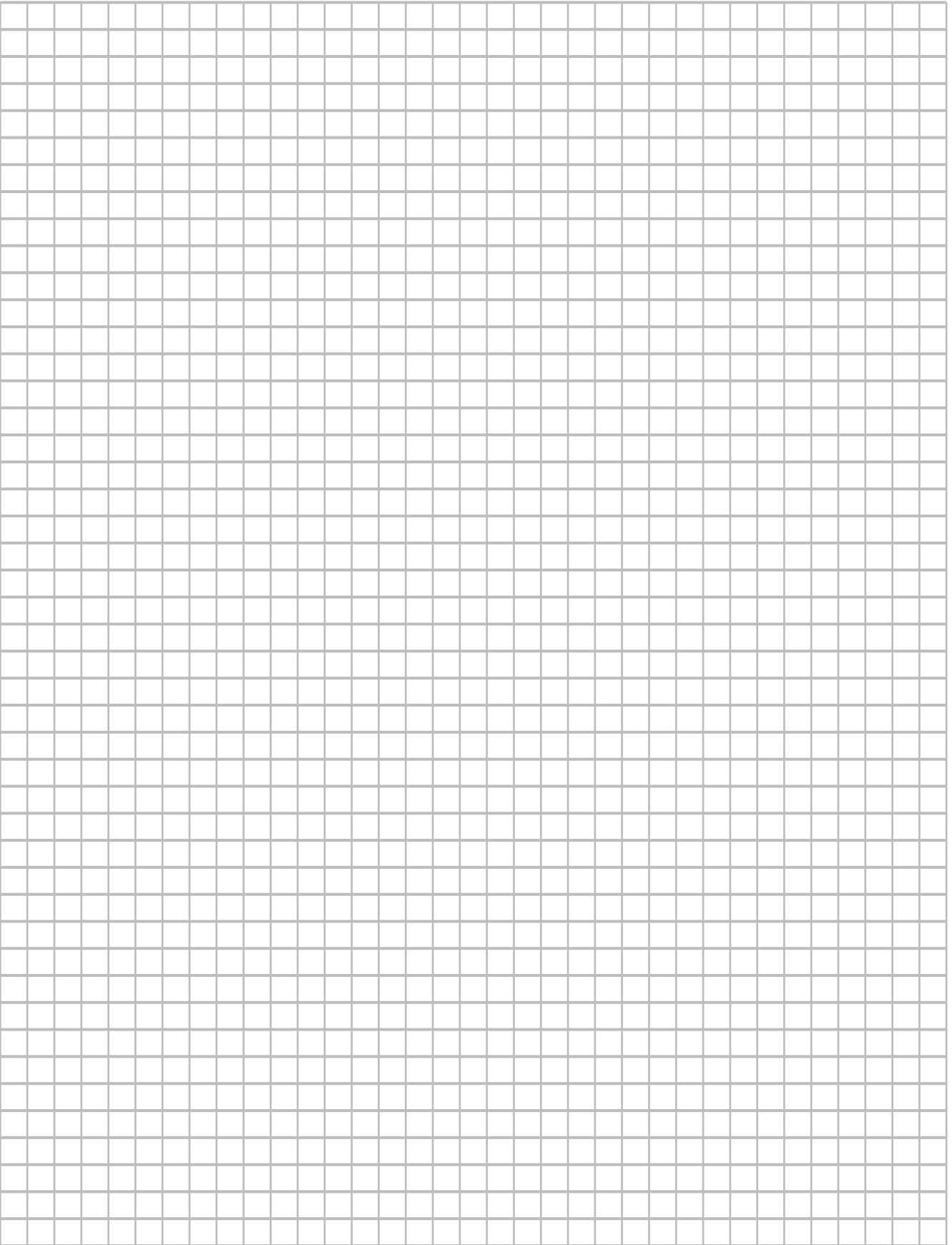

How to Order Models with a Tap

Motor Models

Series	Mounting Type	Motor Type	Frame No.	Shaft Arrangement		Nominal Reduction Ratio	Common Code	Output Power	Voltage	Common Code	Option	Option Description ¹
V	GL	C	12		-	30	N	50	L1	A	X	X=M5 x 0.8 x 12 Tap
V	HL	D	28	L	-	80	N	200	L4	A	X	X=M8 x 1.25 x 20 Tap

How to Order Models with an Optional Bore or Shaft Size

Motor Models

Series	Mounting Type	Motor Type	Frame No.	Shaft Arrangement		Nominal Reduction Ratio	Common Code	Output Power	Voltage	Common Code	Option	Option Description ¹
V	HL	D	28	L	-	80	N	200	L4	A	X	X=1.1250 Inch Shaft

- (Note) 1. Option descriptions should be included along with the main part number when placing an order or submitting a quote request.
 2. If you require an option other than the ones listed it will require a special order.
 3. Please contact our office for delivery times, pricing, and other details regarding these options.

Tapped Output Shafts

Units with frame sizes 18 to 32 come standard with a tap. Optional tapped output shafts are available with the dimensions given in the table below for 12 and 15 frame units. If a tap is required for these units, be sure to mention this when requesting a quote.

- (Notes) • In the table below, a circle means that the tapped output shaft will not add to the lead time. A triangle means that extra time will be required.



Shaft Diameter (Frame No.)	Size × Pitch × Effective Depth	VG (Parallel Shaft)	VH (Right Angle Shaft)		
			L-Shaft	R-Shaft	T-Shaft
12, 15	M 5×0.8 ×12ℓ	○	Not Applicable		
18	M 6×1.0 ×15ℓ	Standard	○	○	○
22, 28	M 8×1.25×20ℓ	Standard	○	○	△
32	M10×1.5 ×25ℓ	Standard	○	○	△

Hollow Bore / Output Shaft Diameters

VF3S models have optional bore sizes that can be ordered per the table below.

Frame No.	Standard or Option	D (H8)	Diameter Tolerance	W	T	G
F3S15	Standard	15 mm	+0.027/-0.000	5 mm	17.3 mm	1.15 mm
	Option	0.625 in	+0.0011/-0.0000	0.1875 in	0.71 in	0.039 in
F3S25	Standard	25 mm	+0.033/-0.000	8 mm	28.3 mm	1.35 mm
	Option	20 mm	+0.033/-0.000	6 mm	38.3 mm	1.15 mm
	Option	0.7500 in	+0.0013/-0.0000	0.1875 in	0.838 in	0.039 in
	Option	1.0000 in	+0.0013/-0.0000	0.2500 in	1.114 in	0.046 in
F3S30	Standard	30 mm	+0.039/-0.000	8 mm	33.3 mm	1.35 mm
	Option	20 mm	+0.033/-0.000	6 mm	43.3 mm	1.15 mm
	Option	25 mm	+0.033/-0.000	8 mm	43.3 mm	1.35 mm
	Option	1.0000 in	+0.0013/-0.0000	0.2500 in	1.114 in	0.046 in
	Option	1.2500 in	+0.0015/-0.0000	0.2500 in	1.366 in	0.056 in
F3S35	Standard	35 mm	+0.039/-0.000	10 mm	38.3 mm	1.75 mm
	Option	25 mm	+0.033/-0.000	8 mm	48.3 mm	1.35 mm
	Option	30 mm	+0.039/-0.000	8 mm	53.3 mm	1.35 mm
	Option	1.0000 in	+0.0013/-0.0000	0.2500 in	1.114 in	0.046 in
	Option	1.2500 in	+0.0015/-0.0000	0.2500 in	1.366 in	0.056 in
	Option	1.3750 in	+0.0015/-0.0000	0.3125 in	1.520 in	0.056 in
	Option	1.4375 in	+0.0015/-0.0000	0.3750 in	1.606 in	0.056 in

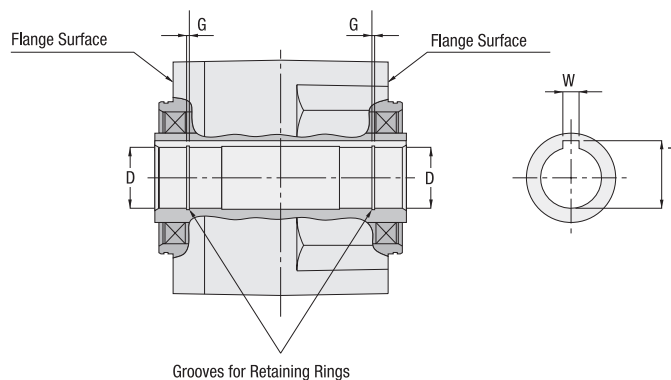

(Notes) • When using one of the hole diameters listed above, you must give proper consideration to tightness with the inserted drive shaft.

VG and VH models have optional shaft sizes that can be ordered per the table below.

Frame No.	Standard or Option	S	Diameter Tolerance	P	T	Q	M
15	Standard	15 mm	+0.000/-0.011	5 mm	5 mm	3 mm	24 mm
	Option	0.625 in	+0.0000/-0.0005	0.1875 in	0.1875 in	0.1085 in	0.97 in
18	Standard	18 mm	+0.000/-0.011	6 mm	6 mm	3.5 mm	27 mm
	Option	0.7500 in	+0.0000/-0.0005	0.1875 in	0.1875 in	0.1055 in	0.97 in
22	Standard	22 mm	+0.000/-0.013	6 mm	6 mm	3.5 mm	35 mm
	Option	0.8750 in	+0.0000/-0.0005	0.1875 in	0.1875 in	0.1035 in	1.57 in
28	Standard	28 mm	+0.000/-0.013	8 mm	7 mm	4 mm	40 mm
	Option	1.1250 in	+0.0000/-0.0005	0.2500 in	0.2500 in	0.139 in	1.77 in
32	Standard	32 mm	+0.000/-0.016	10 mm	8 mm	5 mm	50 mm
	Option	1.2500 in	+0.0000/-0.0005	0.2500 in	0.2500 in	0.138 in	2.17 in

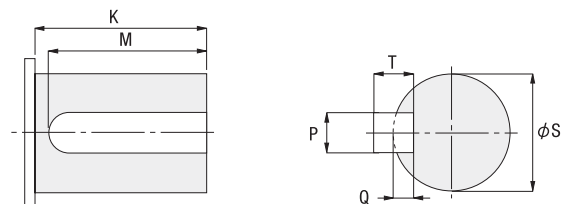

(Notes) • 12 and 15 Frame, 50W gearmotors cannot be ordered with an optional shaft size.
• Dimension K is the same between inch and metric shafts. See more detail on p. T15.