

Single Phase Gearmotors & NEMA Reducers

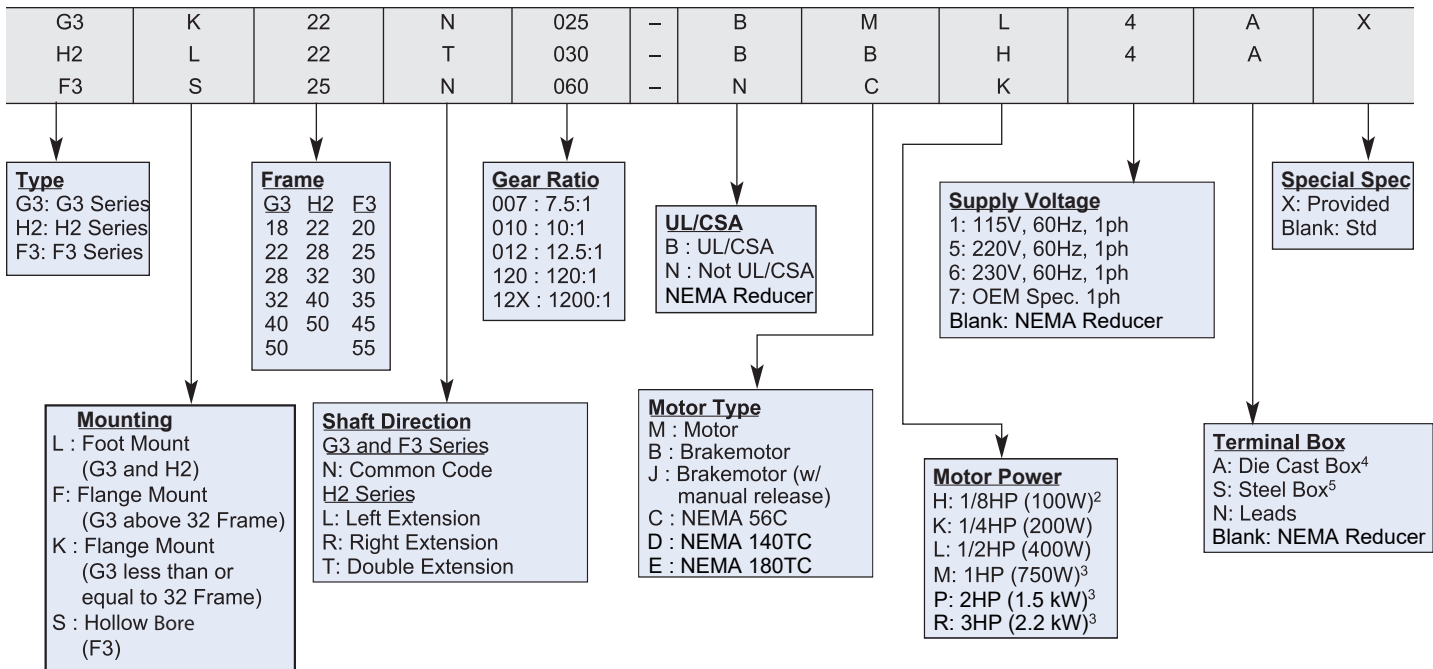

Three Phase-Inverter Duty Gearmotors

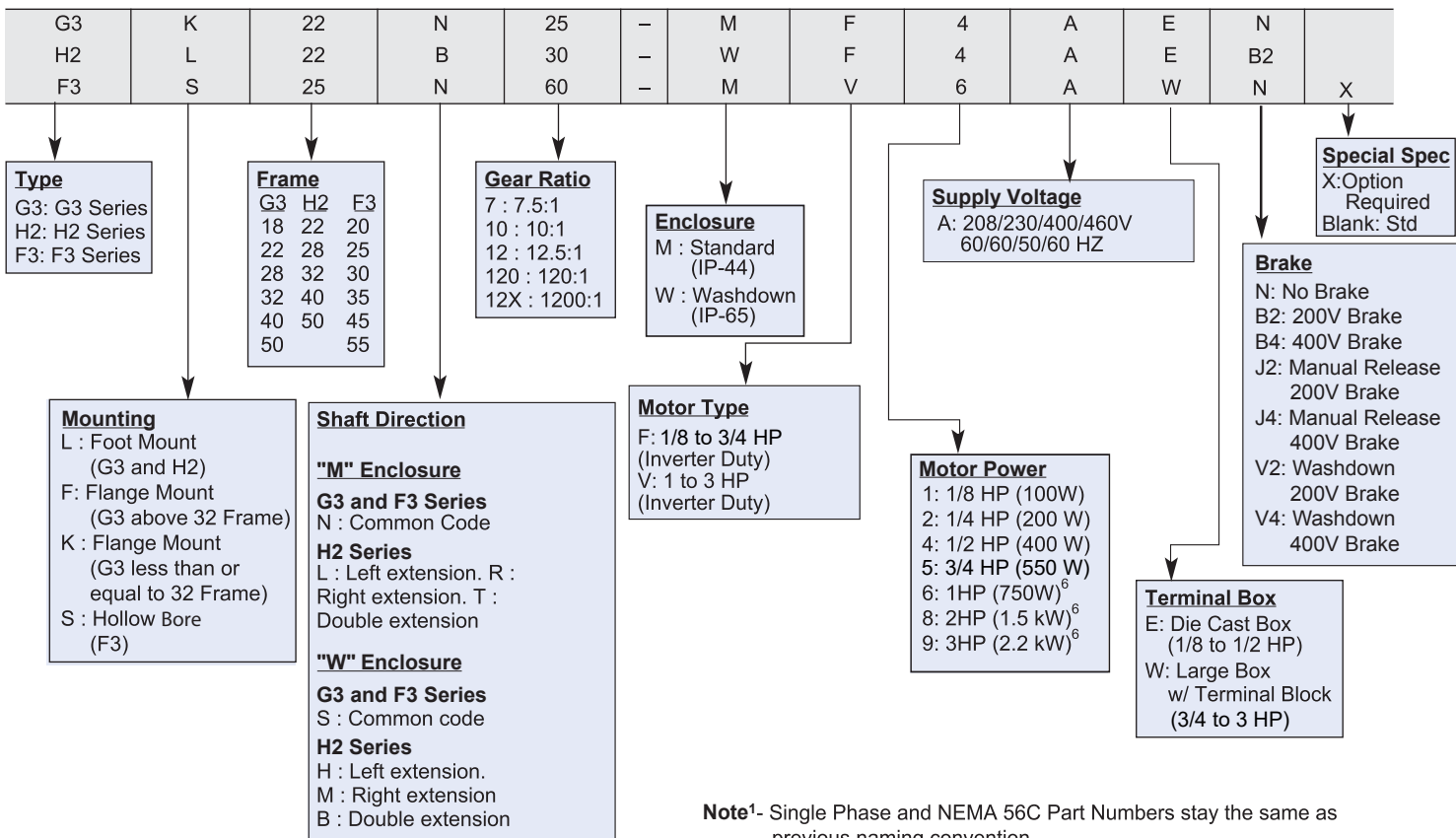

Note¹- Single Phase and NEMA 56C Part Numbers stay the same as previous naming convention

Note²- Not available in a 56C Reducer

Note³- Not available in a Single Phase Gearmotor

Note⁴- For 1/8 and 1/4HP Single Phase Models

Note⁵- For 1/2HP Single Phase Models

Note⁶- 1, 2, and 3 HP Motors meet IE3 Efficiency Standards