









G3 In-line Torque Table (in-lb) (Frame / Torque)

Ratio	RPM	1/8 HP	1/4 HP	1/2 HP	3/4 HP	1 HP	2 HP	3 HP
5	360	22.5	45	89	124	167	338	494
10	180	44	89	178	248	335	668	980
15	120	67	134	268	372	502	1006	1474
20	90	86.7	178	357	487	669	1335	1959
25	72	113	223	446	611	837	1673	2454
30	60	130	268	535	743	1004	2003	2939
40	45	173	346	691	947	1296	2592	3797
50	36	217	432	864	1186	1620	3234	4751
60	30	260	519	1037	1425	1944	3884	5696
80	22.5	346	691	1383	1903	2593	5176	7595
100	18	432	864	1728	2372	3241	6476	9537
120	15	519	1037	2074	2850	3889	7768	
160	11.2	691	1383	2765	3797	5185	10317	
200	9	864	1728	3457	4752	6481	10838	
300	6	1155	2311	4621	6345	8665		
375	4.8	1444	2888	5777	7938	10832		
450	4	1733	3466	6770	9540	10850		
600	3	2311	4621	9243				
750	2.4	2888	5777	10850				
900	2	3466	6770	10850				
1200	1.5	3819	6770	10850				

Foot Mount	Flange Mount	Description
		1/8 ~3 Hp 5:1~200:1 3 Ph Std 3 Ph IP-65 1 Ph Std Optional Brake
		1/8 ~1 Hp 300:1~1200:1 3 Ph Std 3 Ph IP-65 1 Ph Std Optional Brake
		1/4 ~1 Hp 5:1~200:1 NEMA 56C, 140TC,180TC

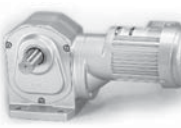

H2 Rt-Angle Torque Table (in-lb) (Frame / Torque)

Ratio	RPM	1/8 HP	1/4 HP	1/2 HP	3/4 HP	1 HP	2 HP	3 HP
5	360	21	42	85	115	159	321	468
10	180	42	85	169	230	317	633	928
15	120	63	127	254	354	476	954	1396
20	90	85	169	338	469	634	1266	1855
25	72	106	211	423	575	793	1587	2324
30	60	127	254	507	690	951	1899	2783
40	45	169	338	676	929	1268	2454	3563
50	36	211	423	845	1159	1585	3061	4491
60	30	254	507	1014	1398	1902	3676	5384
80	22.5	328	654	1308	1797	2452	4899	7187
100	18	410	817	1634	2248	3065	6121	9017
120	15	491	981	1961	2690	3677	7343	10751
160	11.2	655	1308	2615	3593	4903	9797	
200	9	819	1634	3269		6129	10838	
240	7.5	983	1961	3819	5390	6770	10838	
300	6	1069	2170	4227	5806	7926		
375	4.8	1336	2712	5284	7266	9908		
450	4	1603	3255	6341	8717	10850		
600	3	2113	4339	8455				
750	2.4	2642	5424	10568				
900	2	3170	6509	10850				
1200	1.5	3819	6770	10850				
1500	1.2	3818						

Foot Mount	Description
	1/8 ~3 Hp 5:1~240:1 3 Ph Std 3 Ph IP-65 1 Ph Std Optional Brake
	1/8 ~1 Hp 300:1~1500:1 3 Ph Std 3 Ph IP-65 1 Ph Std Optional Brake
	1/4 ~3 Hp 5:1~240:1 NEMA 56C, 140TC, 180TC

F3 Rt-Angle Hollow Bore Torque Table (in-lb) (Frame / Torque)

Ratio	RPM	1/8 HP	1/4 HP	1/2 HP	3/4 HP	1 HP	2 HP	3 HP
5	360	19	40	81	115	159	300	451
7.5	240	28	61	123	159	221	460	672
10	180	38	81	168	221	300	619	902
12.5	144	47	106	212	283	380	761	1115
15	120	57	123	238	336	460	920	1345
20	90	76	168	327	451	619	1221	1796
25	72	97	212	407	558	761	1531	2248
30	60	115	238	486	673	920	1841	2699
40	45	159	327	654	894	1221	2442	3593
50	36	194	407	814	1124	1531	3053	4496
60	30	221	486	982	1354	1841	3682	5390
80	22.5	283	628	1239	1708	2327	4655	6824
100	18	362	770	1548	2133	2903	5823	8532
120	15	433	929	1867	2567	3496	6983	10231
160	11.2	584	1239	2389	3416	4655	9284	
200	9	716	1548	2389	4257	4903	11187	
240	7.5	867	1628	2389	4903	4903	11187	

Shaft/Flange Mount	Description
	1/8 ~3 Hp 5:1~240:1 3 Ph Std 3 Ph IP-65 1 Ph Std Optional Brake
	1/4 ~3 Hp 5:1~240:1 NEMA 56C, 140TC, 180TC