

Part Numbers GTR Mini Series

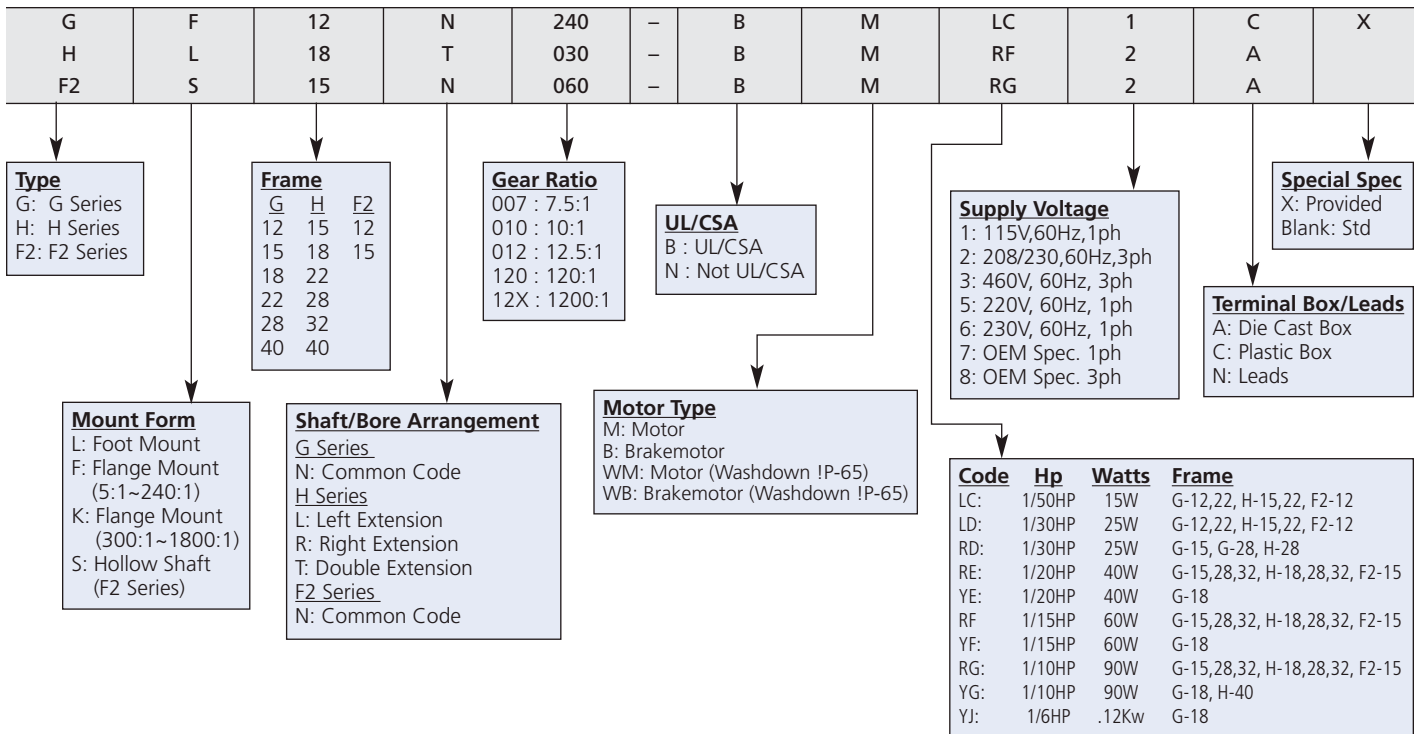

Other Products



GTR Mid Series, 1/8~3 Hp

Please contact Brother for a GTR Mid Series catalog or visit www.BrotherGearmotors.com

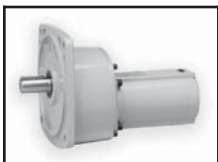

GTR Mini Series, 1/50~1/10 Hp, 300:1 to 1800:1, "GF" Series

Alternative IEC Output Flange with Circular Pilot and Mounting Holes

Please contact Brother for details or visit www.BrotherGearmotors.com