

## Cleaning (Caps, Wiper Blades and Print Heads)

The Wiper Cleaner needs to be replaced regularly. Keep the Print Head Cap and Wiper Blade clean when replacing the Wiper Cleaner. If not, the waste ink may drop on a T-shirt in printing or mis-firing may not be easily improved.

1. Select [ Maintenance ] from the menu by pressing Up/Down Buttons and press OK Button.
2. Select [ Maintenance Parts Exchange ] and press OK Button. The Platen will be loaded and the Wipers will be moved to the cleaning position. Follow the message and turn off the printer.
3. Open the Front Cover with both hands until it is locked with the stopper.

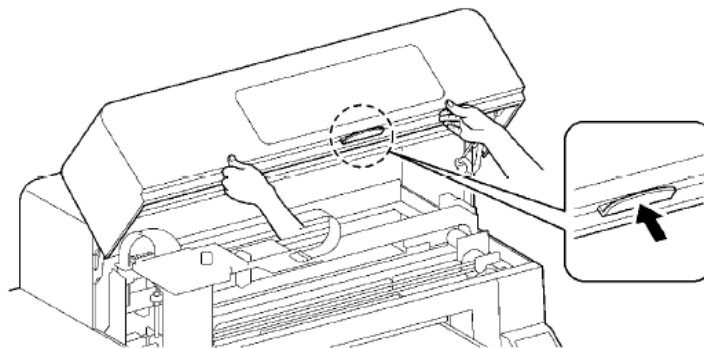

4. Cover your right hand with a plastic bag so that you can hold the used Wiper Cleaner safe and clean. Pick the right edge of the Wiper Cleaner and move slightly to the right (1-2 mm) by your right hand, the claw in the right will be released.

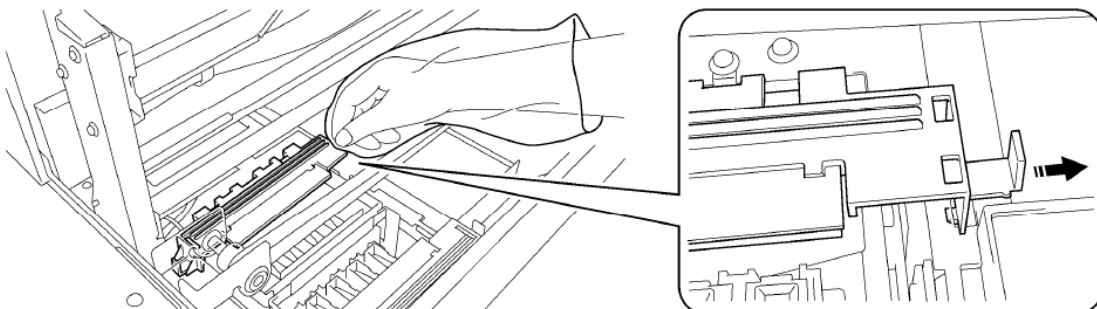

5. Move the Wiper Cleaner slightly to the left (1-2 mm) to release the claw in the left. Pay attention not to tilt the Wiper Cleaner or the waste ink may drop. Keep flat and move slowly.

*Note: Do not tilt the Wiper Cleaner, ink may get on your hands or clothing.*

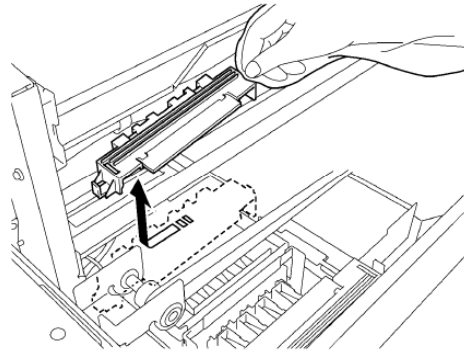

6. Pick the plastic bag on your right hand with your left hand, and wrap the Wiper Cleaner with the plastic bag.

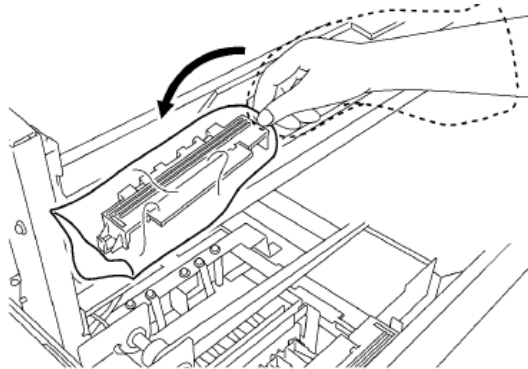

7. Remove the wrapped Wiper Cleaner carefully, not to drop waste ink and dispose of in accordance with local regulations.

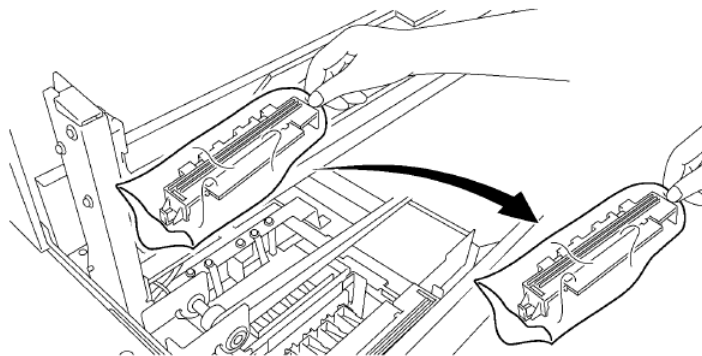

*<Note> Pay attention not to soil the Timing Belt and the other parts with waste ink.*

8. Prepare the Wiper Cleaner, which is in the carton of White, Cyan and Magenta (380 cc only) Ink Cartridge or in the Maintenance Cleaning Kit.

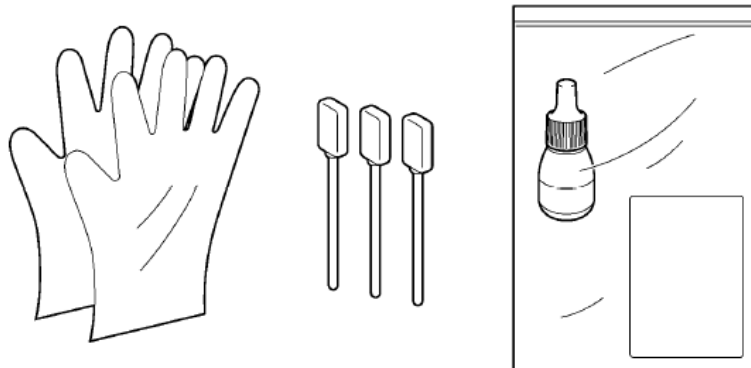

9. Wear the gloves, and wet both sides of a Clean Stick (green grip) with the Wash Liquid.

*<Note> Use only the Wash Liquid included wetting the Clean Stick; using other liquids will cause damage to the Print Heads.*

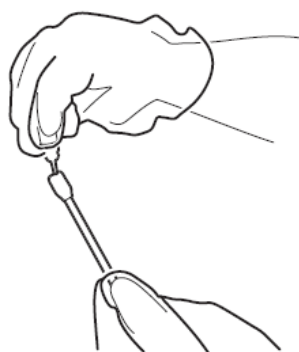

10. Use the one side of wet Clean Stick to clean the front side of the Wiper Blade.
11. Use the other side of the wet Clean Stick to clean the rear of the Wiper Blade. Do not wipe the White / Color with the same Clean Stick.

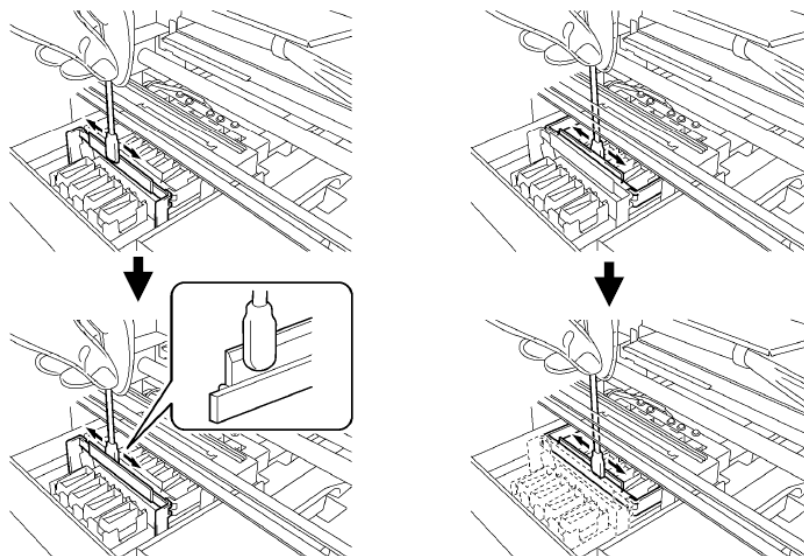

12. Wet other two Clean Sticks and use them to remove ink or dust from the Print Head Caps. Use one side of the Clean Stick to clean one Print Head Cap.

*Note: Do not use dry Clean Stick; it cannot clean ink or dust. It may damage the Print Head Caps. Wipe off the dirty ink of Clean Sticks with soft cloth if it is too dirty and wet with Wash Liquid.*

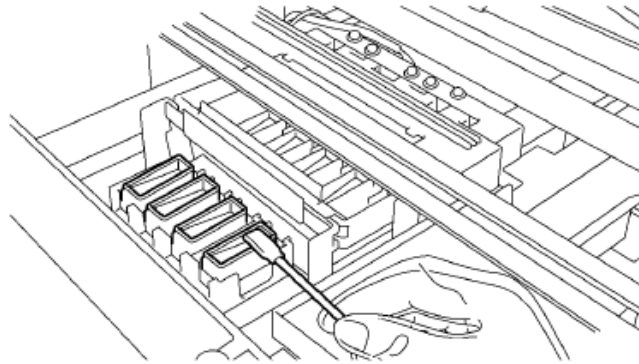

13. Mount the new Wiper Cleaner by following (6) to (4) in the previous pages.

*<Note> Do not give stress to the Timing Belt in mounting the Wiper Cleaner.*

*If your printer turns on with no errors, replacement of the Wiper Cleaner has been completed successfully.*

*If something irregular occurs, e.g. abnormal noise or error "No Wiper Cleaner (CMYK/White)", turn off your printer, and check if the Wiper Cleaner is correctly mounted.*

