

Table 1.3: Brake Data G3, H2, F3 Mid Type 1/8 to 3 Hp Three and Single Phase Standard

Horsepower	1/8 Hp	1/4 Hp	1/2 Hp	1 Hp	2 Hp	3 Hp	1/8 Hp	1/4 Hp	1/2 Hp
Voltage DC (average) (Vdc)	90 Vdc								
Motor	Power Off-Brake On, Spring Close								
Brake Type	Three Phase						Single Phase		
Static Friction Torque (in-lb)	8.67	17.35	34.70	65	130	191	8.67	17.35	34.70
Dynamic Friction Torque (in-lb)	6.90	13.90	27.79	52	104	152	6.90	13.90	27.79
Power (@ 75C) (W)	14	14	16	24	46	46	14	14	24
Current (at 75C) (A)	0.15	0.15	0.18	0.27	0.51	0.51	0.15	0.15	0.27
Allowable Total Work Emax (in-lb)	1.3x10 ⁹	1.3x10 ⁹	1.3x10 ⁹	3.47x10 ⁹	5.2x10 ⁹	5.2x10 ⁹	1.3x10 ⁹	1.3x10 ⁹	3.47x10 ⁹
Allowable Braking Frequency (times/minute)	10/min						6/min		

Fig. 1.10: G3, H2, F3 Mid Type 1/8 to 1/2 Hp Three Phase and Single Phase

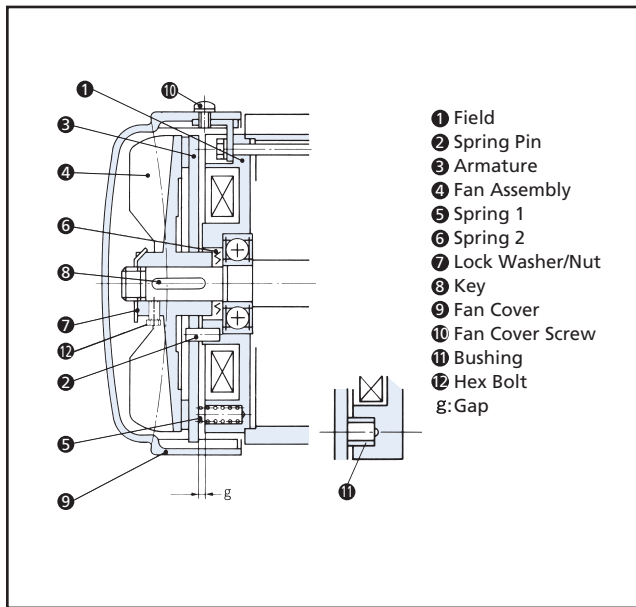

Fig. 1.11: G3, H2, F3 Mid Type 1 to 3 Hp Three Phase

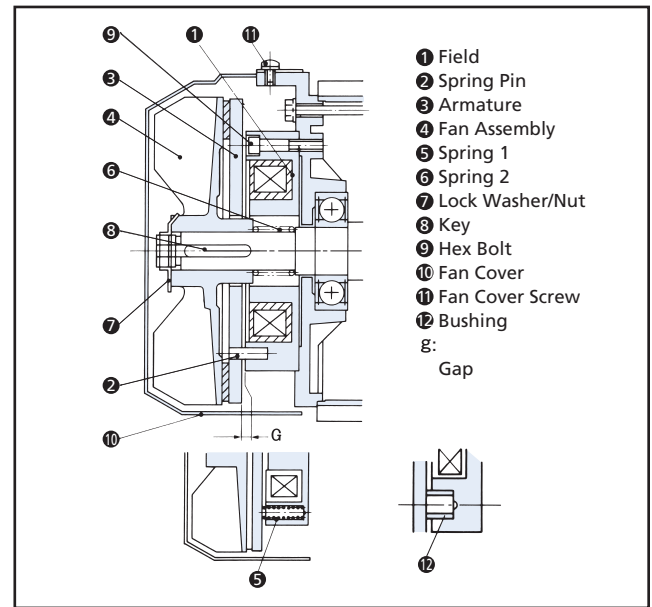
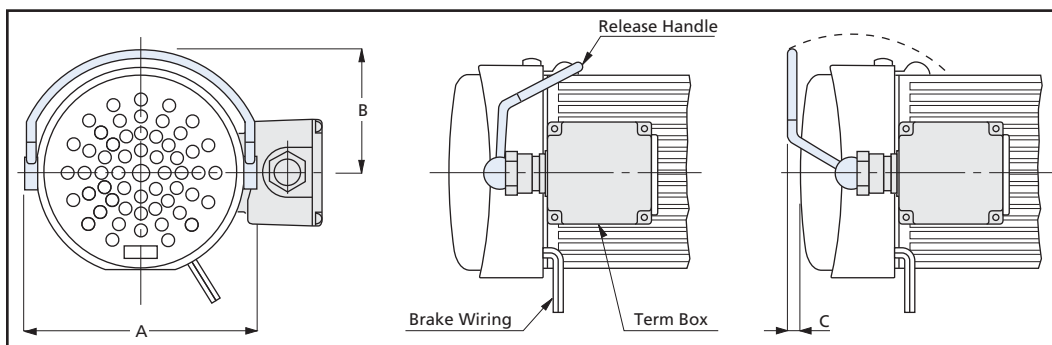

Table 1.4: Manual Release Dimensions

Dim (in)	Hp	1/8	1/4	1/2	1	2	3
A	6.14	6.14	6.14	6.14	7.09	8.35	8.35
B	3.27	3.27	3.27	3.27	4.02	4.88	4.88
C	0.32	0	0	0	0.08	0.24	0.24

Fig. 1.12: Manual Brake Release



Note: Manual Brake release is optional and must be specified on your order.

Table 1.5: Brake Data G3, H2, F3 Mid Type 1/8 to 3 Hp Three Phase IP-65

Horsepower	1/8 Hp	1/4 Hp	1/2 Hp	1 Hp	2 Hp	3 Hp
Brake Type	Power Off-Brake On, Spring Close					n/a
Static Friction Torque (in-lb)	8.67	17.35	34.70	65	n/a	n/a
Dynamic Friction Torque (in-lb)	6.90	13.90	27.79	52	n/a	n/a
Voltage DC (average) (Vdc)	90 Vdc					n/a
Power (@ 75C) (W)	10	16	18	22	n/a	n/a
Current (at 75C) (A)	0.11	0.18	0.20	0.25	n/a	n/a
Allowable Total Work Emax (in-lb)	1.3x10 ⁹	1.3x10 ⁹	1.3x10 ⁹	3.47x10 ⁹	n/a	n/a
Allowable Braking Frequency (times/minute)	10/min					n/a

Fig 1.13: 1/8 Hp IP-65 Brake

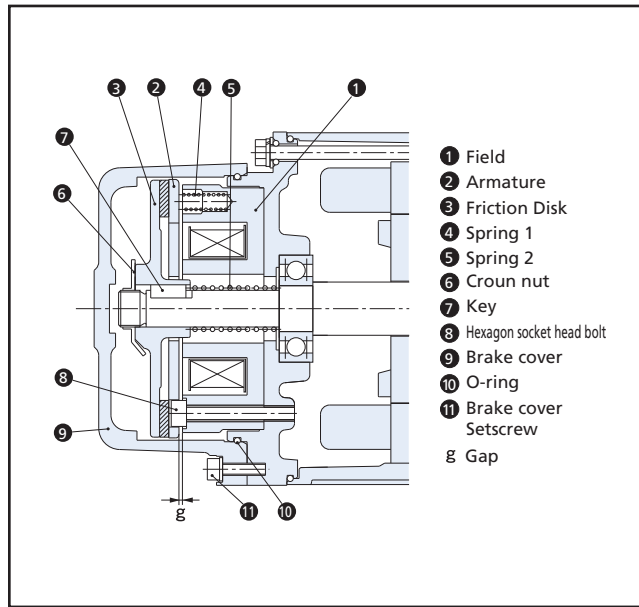
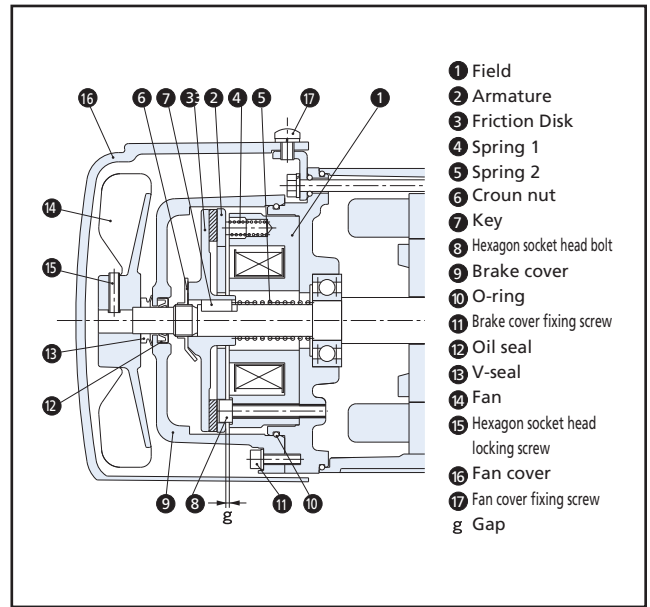

Fig 1.14: 1/4 to 3 Hp IP-65 Brake



Lubrication: NLGI 0 Grease w/ EP Additives (Grams)

Table 1.6A

G3 Frame	Gear Reduction Range		
	5:1~200:1	80:1~240:1	300:1~1500:1
18	65	n/a	n/a
22	130	n/a	n/a
28	210	250	n/a
32	350	400	390
40	580	680	630
50	1000	1150	1100

Table 1.6C

F3 Frame	Gear Reduction Range		
	5:1~60:1	80:1~240:1	300:1~1500:1
20	130	n/a	n/a
25	200	270	n/a
30	320	450	590
35	480	700	930
45	1070	1440	1780
50	2200	n/a	n/a
55	n/a	3800	4190

Table 1.6B

H2 Frame	Gear Reduction Range		
	5:1~200:1	300:1~450:1	600:1~1500:1
22	105	n/a	n/a
28	190	230	n/a
32	370	420	410
40, 1 Hp	500	700	550
40, 2 Hp	600	700	550
50	1200	1350	1300

Notes:

1. The standard grease is lithium based with extreme pressure additives. It is equivalent to NLGI 0 or NLGI 00.
2. MSDS for the grease are available. Please consult Brother or your Brother distributor.
3. If Food Grade grease is required, please use the common code "X" in your part number and specify H1 grease on your purchase order.
4. Food grade grease requires an upcharge from the basic price.

Fig. 1.15: Mid Type: 1/8, 1/4, 1/2, 1, 2, and 3 Hp

Type	115V, 220V, 230V Single Phase 1/8 Hp	115V, 220V, 230V Single Phase 1/4, 1/2 Hp	208/230V Three Phase 1/8, 1/4, 1/2 and 1, 2, 3 Hp
DC Switching Fast Response			
AC Switching (1) Normal Response			
AC Switching (2) Normal Response			

M: Motor Br: Brake S: Reversing switch C: Capacitor MS: Magnetic switch Z: R-C circuit (OP-CRM-2)

Fig. 1.16A Rectifier

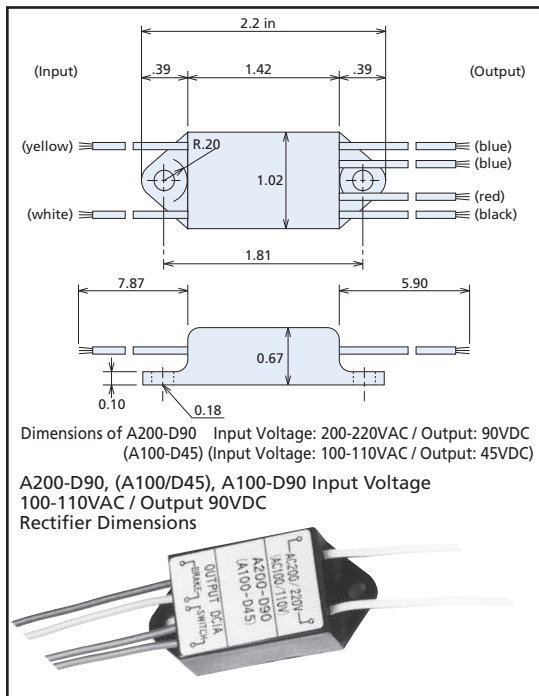

Fig. 1.16B Snubber

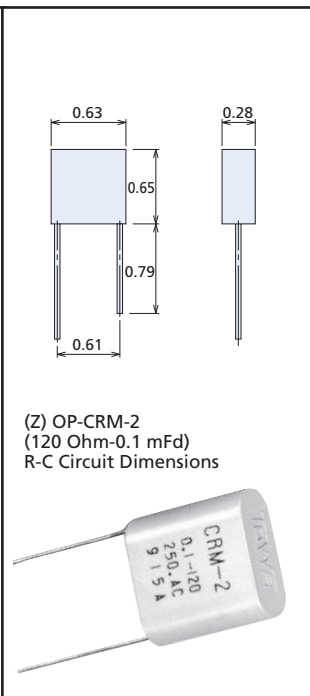
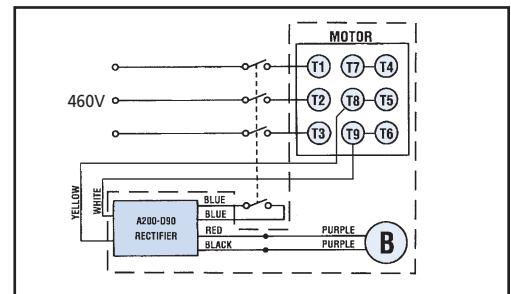

Fig. 1.17: 1/8 - 3 Hp 460V Wiring



* For Wiring with a VFD (Inverter) see page 17.