

# GTR MID Gearmotors

1/8 Hp ■ 1/4 Hp ■ 1/2Hp ■ 3/4Hp ■ 1 Hp ■ 2 Hp ■ 3 Hp

## Instruction Manual



G3 Series



H2 Series

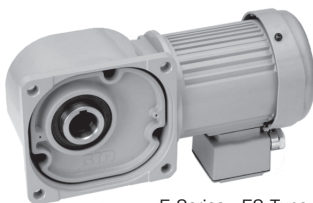

F Series • FS Type

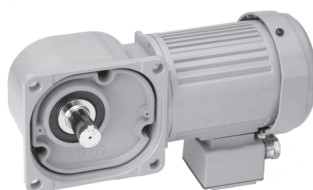

F Series • FF Type



F2 Series • F2S Type  
F3 Series • F3S Type



F2 Series • F2F Type  
F3 Series • F3F Type

## Safe Operation



- The Gearmotor should be operated by a skilled and qualified person. The contents of this Instruction Manual should be carefully read and understood before operating this product.
- This Instruction Manual should be accessible to the person who operates this product.
- This Instruction Manual should be kept in a convenient place for the operator's easy reference.

### Brother International Corporation Gearmotor Division

Address 200 Crossing Boulevard, Bridgewater, NJ 08807  
TEL 866-523-6283  
FAX 908-575-3743  
E-MAIL [gearmotors@brother.com](mailto:gearmotors@brother.com)  
WEB [www.BrotherGearmotors.com](http://www.BrotherGearmotors.com)

Thank you for your purchasing this product.

Potential injuries and/or damage caused by mishandling equipment are classified into two categories, "Danger" and "Caution". The definitions of the classifications are given below with the corresponding graphic symbols.

 <b>Danger</b>	<b>Mishandling the equipment may result in a dangerous situation and may lead to serious or fatal injury to personnel.</b>
 <b>Caution</b>	<b>Mishandling the equipment may result in a dangerous situation and may lead to medium to light injury or damage to the equipment.</b>

Please be aware that even items marked with "CAUTION" may cause fatal accidents. Therefore, it is important to follow the instructions for every item described.

 <b>Danger</b>
<ul style="list-style-type: none"><li>● Use an explosion-proof motor when any explosive or flammable gases are present. Failure to observe this warning may cause explosion, spark, fire, electric shock, physical injury, and/or damage to the equipment.</li><li>● People in charge of transportation, installation, wiring, operation, maintenance, and inspection of the equipment should have sufficient knowledge and technical skill to install electrical and mechanical products. Failure to observe this warning may cause explosion, spark, fire, electric shock, physical injury, and/or damage to the equipment.</li><li>● Do not repair or wire the equipment with the electric power on. Cut the power before working on this product. Failure to observe this warning may cause electric shock.</li><li>● If the equipment incorporating this gearmotor is used in a system for human transport, furnish it with sufficient protective devices for safety and follow any and all local or national codes. Failure to observe this warning may cause physical injury, death and/or damage to the equipment.</li><li>● If the equipment is to be used to drive an elevator, be sure to furnish it with safety devices to prevent the elevator from accidentally falling. Failure to observe this warning may cause physical injury and/or damage to the equipment.</li><li>● Be sure not to get water or oil/grease into the brake unit. Failure to observe this warning may cause brake failure by decreasing brake holding torque.</li><li>● Do not pour water on the motor of IP44. Failure to follow this warning may cause fire, electric shock, physical injury, and/or damage to the equipment.</li></ul>

 <b>Caution</b>
<ul style="list-style-type: none"><li>● Do not use this gearmotor under conditions other than specified on the nameplate or product specifications. Failure to observe this warning may cause electric shock, physical injury and/or damage to the equipment.</li><li>● Do not insert your fingers or any other object into the terminal box, lead wire exit, fan cover, or any other aperture of the gearmotor. Failure to observe this warning may result in electric shock, physical injury, fire and/or damage to the equipment.</li><li>● Do not use a damaged gearmotor. Failure to observe this warning may result in physical injury and/or fire.</li><li>● Do not remove the nameplate.</li><li>● The manufacturer will not warrant and will not be responsible for any product modified or repaired by the user.</li></ul>

## Contents

<b>1 Check When Unpacking</b> ....P.2	<b>7 Operation</b> .....P.22
<b>2 Transportation</b> .....P.2	<b>8 Inspection and Adjustment</b> ...P.23
<b>3 Installation</b> .....P.3	<b>9 Troubleshooting</b> .....P.27
<b>4 Connecting With Other Equipment</b> ...P.4	<b>10 Disposal</b> .....P.28
<b>5 Direction of Rotation</b> .....P.11	<b>11 UL/CSA/CE</b> .....P.29
<b>6 Wiring</b> .....P.12	<b>12 Standard Terms and Conditions of Sale</b> ..P.30

## 1 Check When Unpacking

When unpacking the carton, please check the following items. If you have any problems or questions, please contact the dealer from which the product was purchased or Brother International Corp sales office.

### **Caution**

Check whether the product is the product you ordered. Installing the wrong gearmotor on your equipment may cause physical injury and/or damage to the equipment.

- (1) The ordered product(s), the contents of the box or crate, and the rating indicated on the nameplate are correct.  
(Type, Reduction Ratio, RPM, Horsepower or Watts, Voltage, Frequency, etc.)
- (2) No accidental damage to the product during transportation has occurred.
- (3) Screws or nuts are not loose.
- (4) In case of a brake equipped gearmotor, be sure the rectifier is enclosed.
- (5) In case of a 1/8 Hp single-phase motor be sure the capacitor is enclosed.
- (6) In case of F or F3 series hollow bore/shaft mount type be sure the bore safety cap is enclosed.

## 2 Transportation

### **Danger**

When a product is lifted for transportation, be careful. If a product is dropped and lands on any part of your body it may cause serious injury.

## **Caution**

- Avoid dropping products during transport. When an eyebolt or eyeplate is provided on a gearmotor or reducer, confirm it is secure before using it. After installing the gearmotor or reducer in the equipment do not hoist the entire machine using the eyebolt or eyeplate. Failure to observe this warning may cause physical injury and/or damage to the equipment.
- Before lifting the product confirm its weight using the packing box, product catalog, or by weighing it. Use a lifting device that has enough capacity to handle the weight of the gearmotor. Failure to observe this warning may cause physical injury or damage the equipment.
- If the product is packed in a wooden crate, please do not use a forklift to lift it from the bottom. The crate is not designed for use with a forklift in that manner. If using a forklift, please use a belt to lift the wooden box from the top.

## 3 Installation

Proper installation of a product will ensure reliable service and maximum life.

## **Caution**

- Do not place any flammable object near the gearmotor. Failure to observe this warning may cause fire.
- Do not allow interference with the ventilation of the gearmotor. Be sure to observe the spacing requirements for adequate air flow around the gearmotor. In the case of a fan cooled model, do not block the vent holes on the fan cover. Failure to observe this warning may result in abnormal overheating and/or injury or fire.
- Do not step on a gearmotor. Do not use a gearmotor as a grip to hoist yourself onto a machine. Failure to observe this warning may cause physical injury.
- Do not touch the edge of the shaft of the gearmotor or the key groove of the bore with your bare hands. Failure to observe this warning may cause physical injury.
- Food machine regulations may prohibit the possibility of oil or grease getting into the food area. If this is the case, please use a drip pan to prevent lubrication from getting into the food area. Alternatively, please request that appropriate food grade lubricants are applied.
- Leaking oil may cause products to fail.
- There is possibility scatter the wear debris or iron powders. In case of installing to equipment which will have any issue due to contamination of foreign substance such as food equipment, please install preventive equipment. This could harm the products.
- Vibration resulting from improper installation of the gearmotor or from other sources should be under 0.5G.

### (1) Proper location for installation

Ambient Temperature: 14° to 104° F (-10°C to 40°C) [Note]

Ambient Humidity: Standard Motors: 85% max.

Water resistant IP-65 Motors: 100% max

Altitude: Sea level to 3280 feet (1,000m max.)

Environment: Standard Motors: Well ventilated free from vapor and dust.

Water resistant IP-65 Motors: Place from corrosive gas and explosive gas. Operation submersed in water or in the high-hydrostatic pressure is not permitted.

Note: In a hazardous environment where any explosive and flammable gases exist use an explosion-proof motor.

Installation Location: Standard Motors: Indoors

Water resistant IP-65 Motors: Indoors and Outdoors

[Note] Motor capacity S100 (capacitor operation motor) will be 0°C to 40°C

Target model : H2 series, F series and F3 series

Motor capacity : Single phase 100W

### (2) Direction of Installation

This product can be installed in any direction and any angle due to a grease lubrication system.

### (3) Method for Installation

#### a) Mounting a foot or flange type with a shaft.

- Secure the product with four bolts on a flat and machined surface free from vibration.
- Roughness of the mounting surface should be less than 0.3mm.

#### b) Mounting a hollow bore/shaft mount type.

- The driven shaft should be large enough and supported such that it can handle the weight of the gearmotor or reducer.
- Forces other than the turning or reactive force should not be imposed on the torque arm.
- For frequent start/stops or forward/reverse secure the torque arm with bolts to keep it axially secure.

**Tightening Torque for Torque Arm**

Fixing Hole Metric (mm)	Metric Bolt Size	Tightening Torque (N-m)	Fixing Hole Inch (in)	Inch Bolt Size	Tightening Torque (in-lb)
5.5	M5	2.9	0.20	3/16-18	25
6.5	M6	4.9	0.25	1/4-20	43
8.5	M8	13	0.33	5/16-18	115
11	M10	25	0.43	3/8-16	220
13	M12	44	0.51	7/16-14	390
15	M14	69	0.59	7/16-14	390
18	M16	108	0.71	5/8-11	955
22	M20	294	0.75	5/8-11	2600

### (4) Ventilation Around the Gearmotor

**Minimum Dimension "A" for Proper Ventilation** (mm)

Horsepower	Standard Motor 1 Phase, 3 phase		IP65 Motor 3 Phase	
	Motor	Brake Motor	Motor	Brake Motor
1/8 HP	64	64	64	64
1/4 HP	79	79	79	102
1/2 HP	79	79	79	116
3/4 HP 1HP*	79	79	79	137
2HP*	101	101	101	n/a
3HP*	101	101	101	n/a

\* The 3/4HP, 1HP, 2HP, and 3HP are not available in 1 Phase.

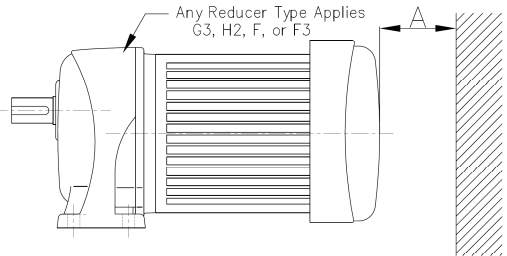

Note: The dimension "A" is the space required for ventilation and for easy removal of the fan or brake cover and adjustment of the brake gap "g" for brake equipped gearmotors. Gearmotors should be mounted to allow ventilation and free air flow around the entire motor diameter. Good ventilation prolongs product life.

## 4 Connecting With Other Equipment

### **Caution**

- When connecting the gearmotor to a load with a chain or belt, make sure of the shaft parallel alignment is precise. Make sure the belt/chain tension is properly adjusted and pulleys or sprockets are parallel.
- When direct coupling, make sure the concentric alignment of shafts is precise.
- Before operation, make sure the set screws for the sprockets, pulleys or coupling are securely tightened. Failure to observe this warning may cause serious injury and/or damage to the equipment.
- Safety guards should be furnished around rotating parts and securely in place before starting the equipment.
- Do not over tension chain or belts. Damage to the gearmotor may occur due to excessive overhung load.
- Avoid excessively rigid direct couplings as damage may occur to the bearings due to high overhung load.

## 1 Direct Connection

Connect the reducer to the other equipment precisely, so that the center of the shaft of both machines will be fully aligned.

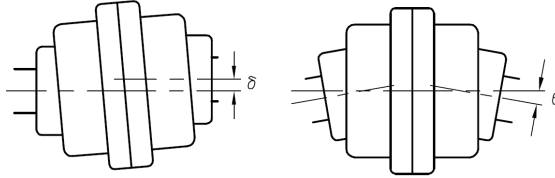

- The displacements  $\delta$  and  $\theta$  should be minimized as much as possible.
- The displacements  $\delta$  and  $\theta$  differ according to the type of coupling. They should be within the allowable value defined by the respective manufacturer.
- Reference: In case of coupling via chain,  $\delta$  should be within 2% of the roller chain pitch and  $\theta$  should be within 1°.

## 2 Attaching Chains, V-Belts, Gears, etc.

- (1) The center of the shaft of the reducer and that of the other equipment should be parallel.
- (2) The tension of Chains or V-Belts must be perpendicular to the center of the shaft.
- (3) Excessive tensioning of the chain or V-belt may result in damage to the bearings of the shaft.
- (4) If the chain is too loose (or slack), shock loading will occur when the drive shaft starts rotation.

This can result in damage to the reducer and/or the equipment. Therefore, adjust the tension of the chain properly.

### Proper Installation

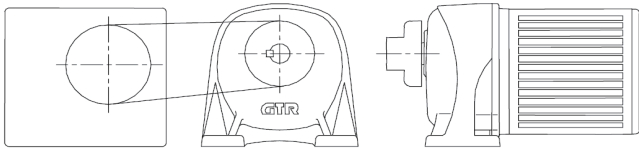

- The tension of V-belt and chain are properly set.
- The pulley and sprocket are properly positioned on the gearmotor shaft. The chain/V-belt is as close to the gearmotor output shaft bearing as possible. This minimizes overhung load and promotes longer bearing life.

### Improper Installation

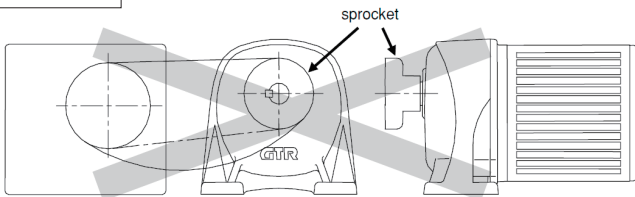

- The Chain is too loose.
- The sprocket is applied to the shaft improperly. The chain or V-belt is set too far from the gearmotor output shaft bearing. This may lead to excessive overhung load (OHL) and shortens bearing life.

### 3 Attaching/Detaching a Driven Shaft to/from F or F3 Type Hollow Shaft

#### ●Attaching a Driven Shaft to the Reducer Hollow Shaft

- (1) Apply an extreme pressure agent such as molybdenum disulfide on the surface of driven shaft and the bore of the hollow shaft to avoid seizing.
- (2) If the load is uniform (low impact) a loose fit is recommended for the tolerance of driven shaft.
- (3) If a shock load or heavy radial load will be applied to the shaft, the fit should be tighter.
- (4) If the fit is tight tap on the end of the hollow drive shaft gently with a plastic or wooden hammer. Do not hit the gear casing with the hammer.
- (5) If the fit is extremely tight, smooth insertion can be achieved if you prepare a jig as shown in the figure below.
- (6) The length of the driven shaft and the fixing key should be positioned within the space where the bore tolerance is tight (The key should not be seated in the central relief area where the bore is larger).

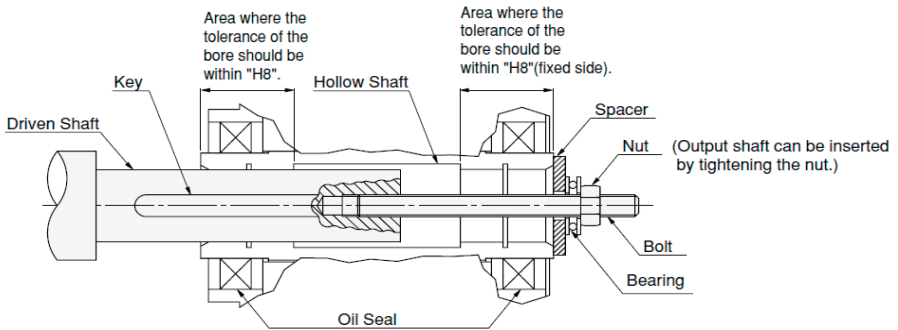

Figure-1

(Spacer, nut, bolt, key and jig parts are not supplied by Brother)

#### ●Connecting Reducer with Driven Shaft

##### ① Driven shaft with a shoulder

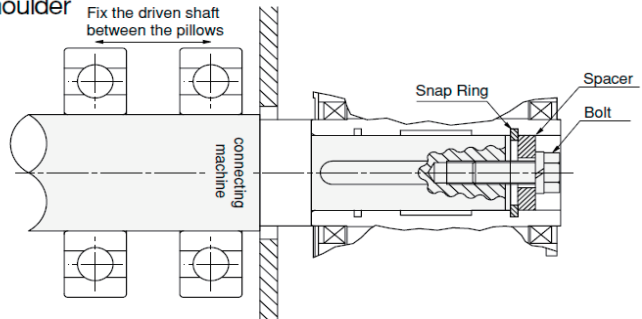

Figure-2 Fixing by spacer and snap ring

(Spacer, nut, bolt, key and jig parts are not supplied by Brother)

(Note: Excessive tightening of the bolt may cause the deformation of the snap ring.)

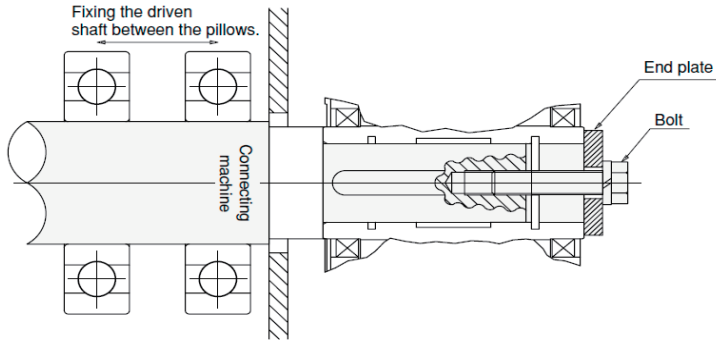

Figure-3 Fixing by End plate  
(End plate and bolt parts are not supplied by Brother)

**⚠ Danger**

A plastic bore cover is supplied with each FS, F2S, or F3S type unit to cover the exposed rotating bore. If you cannot secure the safety cover supplied, please prepare a cover yourself. Failure to cover the exposed rotating bore may result in damage to the equipment or injury.

② Driven shaft without a shoulder

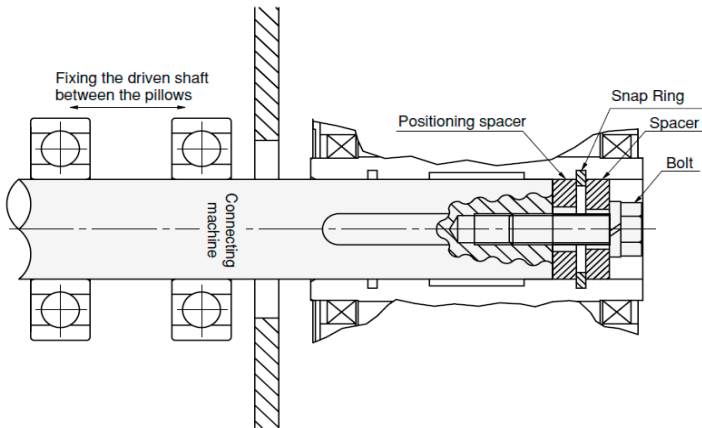

Figure-4 Fixing by spacer and snap ring  
(Spacer, positioning spacer, bolt and snap ring are not supplied by Brother)

Note) The positioning spacer should not have a tight fit. It should have a loose fit and be concentric such that it does not interfere with the I.D. of the bore as it rotates. Excessive tightness or inaccuracy of the spacer's diameter may be a cause of rubbing interference with the bore. The positioning spacer is useful when the resulting position of the driven shaft is not known. In case the length of the driven shaft is precisely known, the positioning spacer is not necessary. A properly applied positioning spacer promotes easier removal of the shaft from the bore.



## ● Recommended Size for Securing Parts

### Inch Dimension Bore

Bore (in)	Bolt		Spacer		
	Internal	External	O.D. (in)	I.D. (in)	T (in)
0.7500	1/4-20X0.75	1/4-20X1.25	0.73	0.28	0.125
1.0000	1/4-20X0.75	1/4-20X1.25	0.98	0.28	0.125
1.2500	5/16-18X0.75	5/16-18X1.5	1.23	0.35	0.188
1.4375	3/8-16X1.25	3/8-16X1.75	1.42	0.43	0.188
1.6875	3/8-16X1.25	3/8-16X2	1.67	0.43	0.250
1.9375	7/16-14X1.25	7/16-14X2.5	1.92	0.51	0.250
2.0000	7/16-14X1.25	7/16-14X2.5	1.98	0.51	0.250

### Metric Dimension Bore

Bore (mm)	Bolt		Spacer		
	Internal	External	O.D. (mm)	I.D. (mm)	T (mm)
20	M6X16	M6X30	19.5	7	3
25	M6X16	M6X30	24.5	7	4
30	M8X20	M8X40	29.5	9	5
35	M10X25	M10X40	34.5	11	5
45	M10X25	M10X50	44.5	11	5
50	M12X30	M12X60	49.5	13	6
55	M12X30	M12X60	54.5	13	6

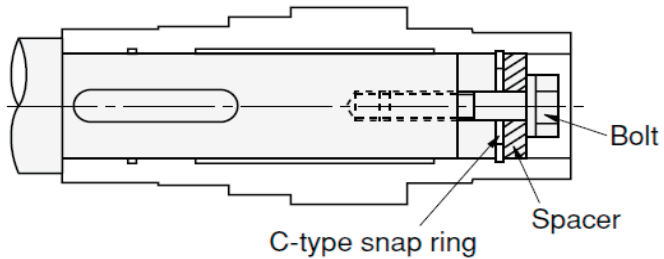

Figure- 5 Recommended Size of Securing Parts

# Recommended Dimensions of the Shaft from the Shoulder

## Inch Dimension Bore

Bore Diameter (Inch)	Shaft (Inch Dimension)						
	O.D. (in)	L1 (in)	L2 (in)	L3 (in)	L4 (in)	Key (in)	Tap T
0.7500	0.7500 in +0.0/-0.0008	0.945	3.125	1.125	0.1875	0.1875	1/4-20X0.50
1.0000	1.0000 in +0.0/-0.0008	1.063	3.938	1.500	0.2500	0.2500	1/4-20X0.50
1.2500	1.2500 in +0.0/-0.0010	1.299	4.000	1.875	0.2500	0.2500	5/16-18X0.63
1.2500	1.2500 in +0.0/-0.0010	1.496	4.500	1.875	0.2500	0.2500	5/16-18X0.63
1.3750	1.3750 in +0.0/-0.0010	1.969	5.375	2.063	0.3125	0.3125	3/8-16X0.75
1.5000	1.5000 in +0.0/-0.0010	2.165	5.375	2.250	0.3750	0.3750	3/8-16X0.75
2.0000	2.0000 in +0.0/-0.0012	2.402	7.125	3.000	0.5000	0.5000	7/16-14X1.0

## Metric Dimension Bore

Bore Diameter (Metric)	Shaft (Metric Dimension)						
	O.D. (mm)	L1 (mm)	L2 (mm)	L3 (mm)	L4 (mm)	Key (mm)	Tap T
20	20h <sub>7</sub>	24	80	30	6	6	M6X12
25	25h <sub>7</sub>	27	100	37.5	8	8	M6X12
30	30h <sub>7</sub>	33	102	45	8	8	M8X16
35	35h <sub>7</sub>	38	117	52.5	10	10	M10X20
45	45h <sub>7</sub>	50	137	67.5	14	14	M10X20
50	50h <sub>7</sub>	55	138	75	14	14	M12X24
55	55h <sub>7</sub>	61	182	82.5	16	16	M12X24

Note: Refer to the product catalog for Dimensions L and P.

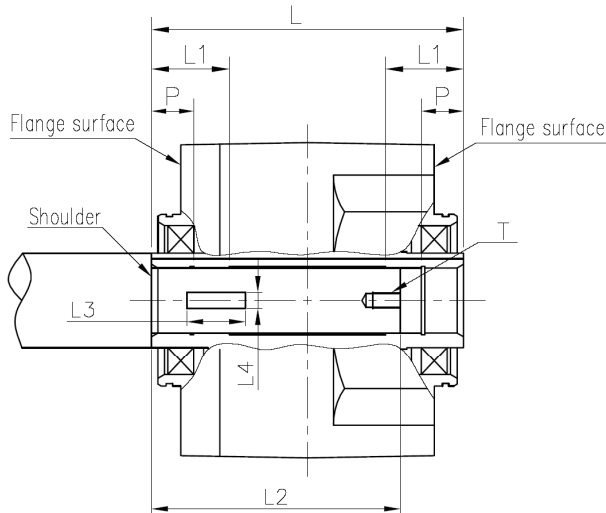

Figure-6 Recommended Dimensions of the Driven Shaft

## Designing your Own Shaft

The usable key length "L3" should be greater than 1.5X the diameter of the driven shaft.

The Key should be engaged with at least half of the length L1.

The minimum length of shaft engaged inside the bore is approximately  $(L - L1) + ((L1 - P)/2)$ .

For dimensions L and P refer to the product catalog, the www or request a drawing from Brother or your Brother distributor.

The recommended dimension L2 is not essential. If your application requires a different length or if you prefer a different method of securing the shaft, it may be acceptable for your application.

## Removing the Shaft from the Hollow Bore.

Avoid applying excessive force to the casing and/or the hollow shaft. Smooth detachment can be obtained by using a jig as shown in the figure below.

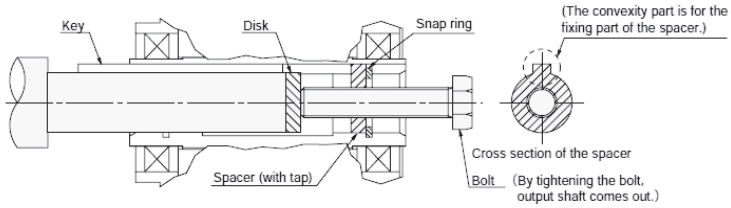
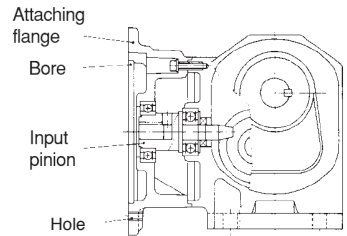

Figure-7 Jig for Removing the Shaft  
(Spacer w/ tap, disk, bolt and snap ring are not supplied by Brother)

## Attaching a Motor to a NEMA C-Face Reducer

### ●Attaching Procedure

- (1) Confirm the key is securely inserted in the key slot of the motor input shaft.
- (2) Align the keyway of the motor with the keyway of the reducer input bore. Gently insert the shaft into the reducer bore.
- (3) Confirm the motor shaft is securely inserted with the key fully engaged.
- (4) Secure the motor to the reducer using 4 flange bolts. (bolts not provided by Brother)



### ●Cautions when Attaching the Motor

- (1) Wipe off any rust and dust and apply an anti-seizing agent to the motor shaft.
- (2) When inserting the motor shaft, do not hit the motor or reducer with a hammer, nor forcibly insert the motor shaft.
- (3) Take advantage of the tightening force of the bolts to fully insert the shaft if required. Failure to observe this warning may cause damage to the bearing and/or abnormal noise.
- (4) Observe the motor weight limit guidelines shown in the Table.

### ●Motor Mass Limit Guideline

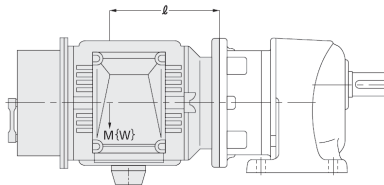

$l$  (in): Length from reducer flange to center of motor  
 $W$ (lb): Weight of the motor in lbs.

Horsepower (4 Pole, Induction motor)	$l \times W = M$
1/4 Hp	$M < 240$ in-lb
1/2 Hp	$M < 275$ in-lb
1 Hp	$M < 300$ in-lb
2 Hp	$M < 730$ in-lb
3 Hp	$M < 820$ in-lb

- (1) The limit of vibration that a gear reducer can withstand is 0.5G. If the vibration is greater than 0.5G, or if the motor mass limit is above the "M" limitation, the casing of the reducer and/or the reducer flange may be damaged. The motor may fall off the reducer and cause injury or damage to the equipment. The motor should be supported by a separate device supplied by the user for safety.
- (2) Before using other manufacturer's motors with our reducer, you should carefully read this Instruction Manual and understand the contents. Failure of a reducer caused by poor installation will not be warranted.

# 5 Direction of Rotation

## G3 Series

1/8 Hp		1/4 Hp, 1/2 Hp, 3/4 Hp, 1 Hp, 2 Hp, 3 Hp	
5:1 to 50:1	Same Direction	5:1 to 30:1	Same Direction
60:1 to 200:1	Counter Direction	40:1 to 200:1	Counter Direction
300:1 to 1200:1	Same Direction	300:1 to 1200:1	Same Direction

## H2 Series

1/8Hp, 1/4Hp:	5:1~60:1 and 600:1~1500:1	1/8Hp, 1/4Hp:	80:1~450:1
1/2Hp, 3/4Hp, 1Hp:	5:1~60:1 and 300:1~1500:1	1/2Hp, 3/4Hp, 1Hp:	80:1~240:1
2Hp, 3Hp:	5:1~30:1	2Hp, 3Hp:	40:1~240:1

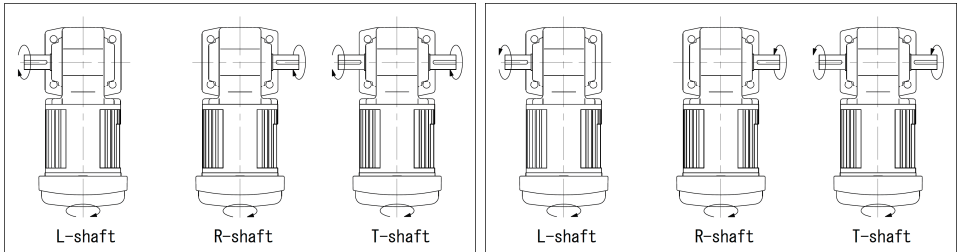

## F Series

1/8Hp, 1/4Hp, 1/2Hp, 1 Hp:	5:1~60:1 and 300:1~1500:1	1/8Hp, 1/4Hp, 1/2Hp, 1 Hp:	80:1~240:1
2Hp, 3Hp:	5:1~30:1	2Hp, 3Hp:	40:1~240:1

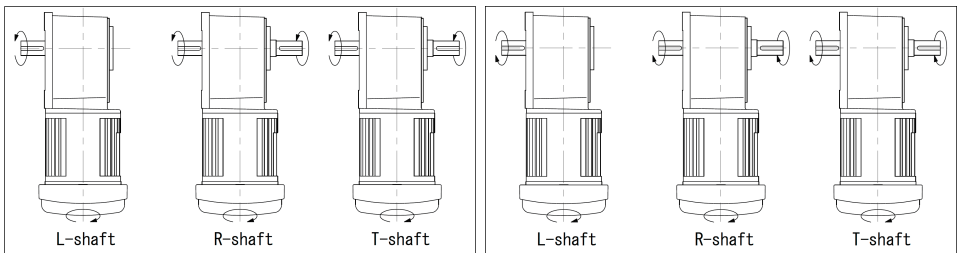

### F3 Series

1/8Hp: 5:1~60:1 and 300:1~1500:1

1/4Hp: 5:1~60:1 and 300:1~1200:1

1/2Hp: 5:1~60:1 and 300:1~600:1

3/4Hp, 1Hp: 5:1~60:1 and 300:1

2Hp, 3Hp: 5:1~60:1

1/8Hp, 1/4Hp, 1/2Hp, 3/4Hp, 1Hp, 2Hp: 80:1~240:1

3Hp: 80:1~120:1

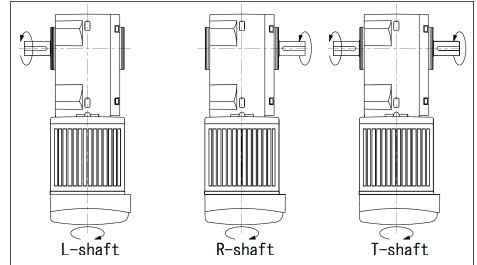
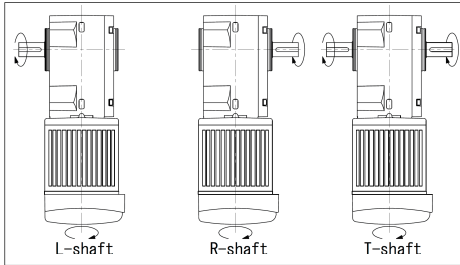

## 6 Wiring

### 1 Direct Connection

#### **Danger**

- When connecting power to the machine, follow the instructions shown on the connection diagram in the terminal box or in this Instruction Manual. Failure to observe this warning may cause electric shock or fire.
- Do not bend, pull, or tuck motor cables or lead wires forcibly. Failure to observe this warning may cause electric shock.
- Be sure to ground the earth terminal, lead wire, or lug. Failure to observe this warning may cause electric shock.
- Be sure to use the power source specified on the name plate. Failure to observe this warning may cause the motor to burnout and/or fire.
- Avoid exposing the power rectifier or capacitor to water. Failure to observe this warning may cause electric shock, damage to the equipment, or fire.

## **Caution**

- 1/8 Hp single-phase motors have a thermal protector built in. If you suspect the thermal protector has tripped, switch off the power to the gearmotor and/or the machine before attempting any inspection.
- 1/8 Hp single phase motors trip temperature is  $120^{\circ}\text{C}\pm 5^{\circ}\text{C}$ , Reset temperature: under  $105^{\circ}\text{C}$ . The gearmotor will be hot if the thermal has tripped. Do not touch it with your bare hand as this will cause a burn injury.
- Do not touch the terminals or un-insulated wire connections when inspecting the insulation resistance. Failure to observe this warning may cause electric shock.
- Wires should be connected properly using the specified electrical standard or safety code. Failure to observe this warning may cause electric shock, fire or physical injury.
- Three phase motors are not equipped with thermal protective devices. Other protective devices such as a circuit breaker, fuse, or thermal relay are recommended. If "CE" is required, a thermal relay certified for use in Europe should be used. The thermal set value should be the same as the current value specified in the name plate. Failure to observe this warning may cause damage to the equipment, electric shock, fire or physical injury.
- When operating a gearmotor not connected to a load, remove the key from the output shaft. Failure to observe this warning may cause physical injury.
- Check the direction of rotation before connecting the gearmotor to the machine's load. Rotation in the wrong direction may cause physical injury and/or damage to the equipment.
- If a 460V class inverter is used to drive the motor, use a control filter or a reactor with the inverter. Breakdown of motor insulation due to repetitive and/or extreme voltage spikes caused by normal operation of the inverter may cause damage to the equipment or fire.
- 1/8 Hp single phase motors use a continuous running type capacitor. Do not substitute a starting capacitor intended for intermittent duty use. A starting type capacitor will fail when used with a permanent split capacitor motor. Use of a starting capacitor may cause damage to the equipment or failure of the capacitor. For replacement capacitors, please consult Brother or your Brother Distributor.
- Do not damage the vinyl coating of the capacitor. Damage may cause electric shock.
- Voltage drop in the wiring should be kept above 2%. Excessive length of wiring may cause a severe voltage drop. Voltage drop reduces starting capacity and may result in the load not starting.
- When reversing either a three phase or a single phase gearmotor be sure to fully stop rotation before starting in the reverse direction. Failure to completely stop before reversing may cause physical injury and/or damage to the equipment.
- Reversing a 1/8 Hp single phase PSC motor without completely stopping first may result in the motor not reversing and running in the same direction. This may cause physical injury and/or damage to the equipment.
- When using a gearmotor with a brake do not energize the brake coil continuously while the motor is not running. The brake coil of totally enclosed, fan cooled motors may rely on the motor fan for cooling. Continuous operation without the effect of the fan may cause the brake coil to burn out and/or fire.
- Totally enclosed, non-ventilated, brake-equipped motors do not rely on the fan for cooling. However, continuously energizing the coil without motor operation may still cause damage.
- If a gearmotor with a brake is used as a lift or hoist; DC Switching wiring should be used. Failure to use DC Switching may result in the lift or hoist falling and causing damage to the equipment or physical injury.

## Special Notes About Wiring

- (1) As the rectifier unit contains diodes, improper wiring may cause fatal short-circuiting and breakage of the unit. So, special care should be taken for wiring.
- (2) In case DC Switch is adopted, DC110V<DC220V>, contact rated DC13 class is recommended in order to cut off the inductive load (DC coil). Please contact us for details.  
\* The capacity in the parenthesis < > is the one at 400V with brake (yellow lead wire).
- (3) The direction of rotation of the output shaft varies according to the speed reduction ratio of the gear head. Therefore, be sure to confirm the speed reduction ratio before wiring.
- (4) The voltage between the capacitor terminals of the single-phase motor will become nearly twice as much as that in the power source of the motor. Therefore be sure to insulate wires at the terminals for safety.

## Special Notes About Grounding

- ① Ground should be connected to the provided ground terminal, lead wire, or lug.
- ② The cross-section of the earth wire should be AWG18 (0.87mm<sup>2</sup>) minimum for 1/8 Hp, 1/4 Hp, or 1/2 Hp motors.
- ③ The cross-section of the earth wire should be AWG16 (1.25mm<sup>2</sup>) minimum for 3/4Hp, 1Hp, 2 Hp, or 3 Hp motors.
- ④ The earth wire should be longer than the lead wire of the power source of the motor.

## 2 Wiring a Gearmotor

For standard gearmotors, the wiring described below is recommended. The direction of rotation referenced is as viewed from the back of the motor. Counter clockwise is the forward direction for 3-phase motors. Clockwise is the forward direction for single-phase motors.

### Three Phase Motors Lead Wire Type : 1/8 Hp, 1/4 Hp, 1/2 Hp

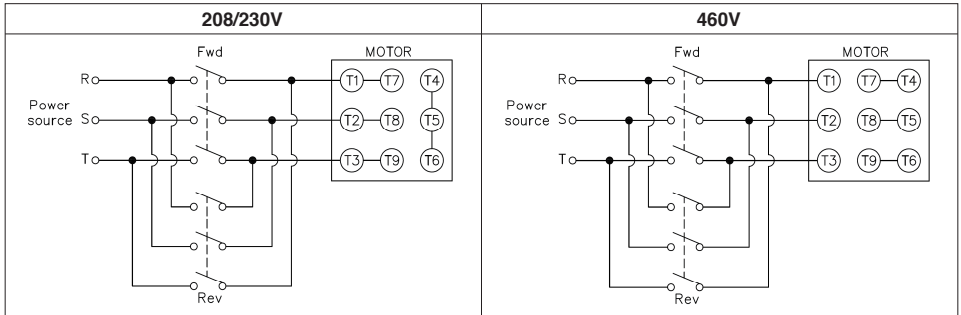

### Terminal Box Type : 3/4 Hp, 1 Hp, 2 Hp, 3 Hp

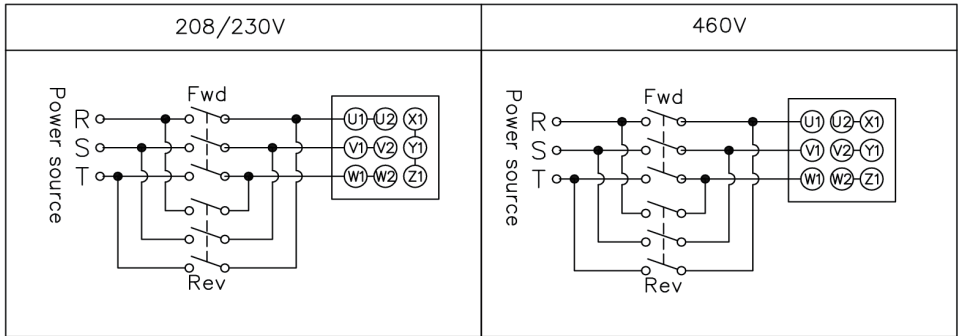

●Precautions for Terminal box/base.

- (1) Please do not remove terminal box/base.  
If the direction of the lead wire outlet needs to be changed, please consult Brother.
- (2) Please use the included nut and short bar for wiring.  
Set the fastening torque for the nut at 1.2~1.5N·m {11~13in-lb} .
- (3) There is a rubber sheet for insulation on the terminal box lid.  
Do not remove. May cause short circuit and/or electrocution.
- (4) The fastening torque for W-type boxes is set at 1.8~2.5N·m {16~22in-lb} .

### Single Phase Motors: 1/8 Hp (Permanent Split Capacitor Type)

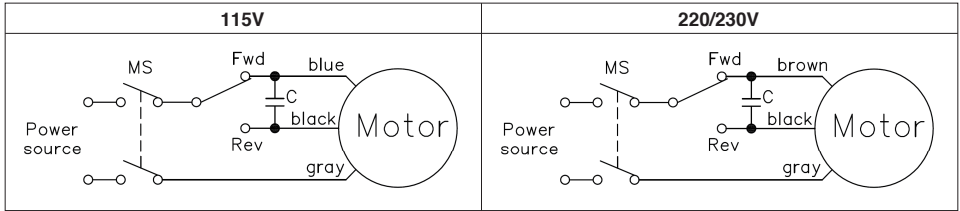

### Capacitor “C” used with PSC Type Motor

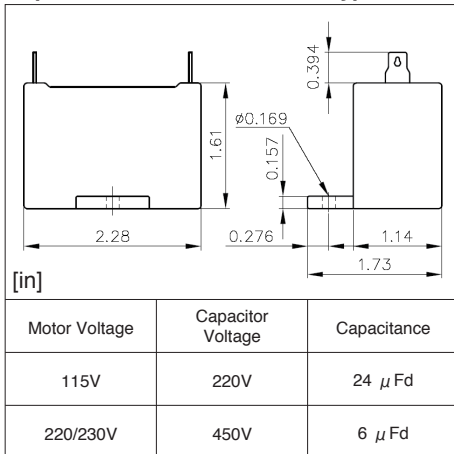

- 1/8 Hp single phase motors are permanent split capacitor (PSC) type motors. The starting torque of a PSC motor is 80%~85%
- PSC motors use a capacitor that remains in the circuit permanently. The capacitor needs to be mounted separately by the User.
- Be careful not to substitute an intermittent duty “starting capacitor” for use with a PSC motor. Consult brother if you are unsure.
- The capacitor Voltage is 2X that of the Motor Voltage because the voltage across the capacitor terminals will become nearly 2X that of the input voltage.



## Single Phase Motors: 1/4 Hp, 1/2 Hp (Capacitor Start type)

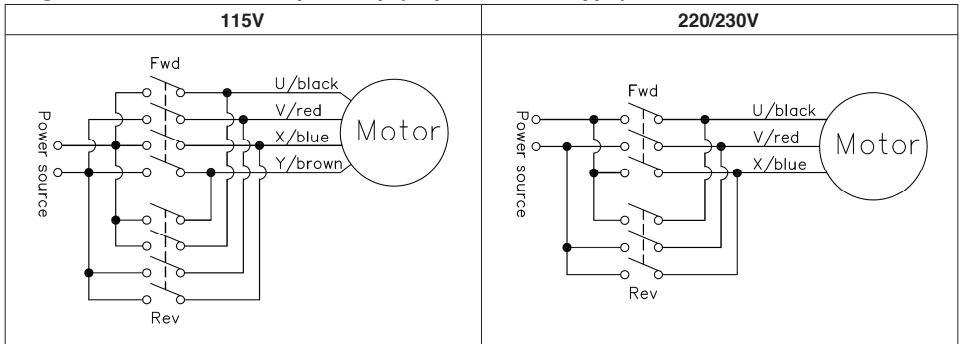

### 3 Wiring a Gearmotor with a Brake

- (1) If a gearmotor is used in the applications where quick braking is required, such as lift, "DC Switching" wiring should be employed.
- (2) In case of "DC Switching" wiring, it is recommended to insert the surge suppressor in between the connecting points. (Varistor voltage are 423~517V at 200V brake and 820~1,000V at 400V brake.)
- (3) The brake voltages are DC90V for 200V brake (blue lead wire) and DC180V brake for 400V brake (yellow lead wire).
- (4) In case DC switch is adopted, DC110V <DC220V>, contact rated DC13 class is recommended in order to cut off the inductive load (DC coil). Please contact us for details.  
\* The capacity in the parenthesis < > is the one at 400V with brake (yellow lead wire).
- (5) As the rectifier unit contains diodes, improper wiring may cause fatal short-circuiting and breakage of the unit. So, special care should be taken for wiring.
- (6) When operating the machine with inverter, refer to the "Cautions for operation with an inverter".
- (7) When wiring for 460V (no inverter/VFD) the 220/230V AC voltage to power the rectifier can be tapped off the motor coil. Please see the wiring diagrams for details. (Caution: do not tap the coil voltage to power a brake coil if an inverter (VFD) is used.)

## Brake Lag Time [sec]

### Standard Type

Type	Motor Type		
	Three Phase: 208/230/460V 1/8Hp, 1/4Hp, 1/2Hp, 3/4Hp, 1Hp	Three Phase 208/230/460V 2Hp, 3Hp	Single Phase 115V, 220/230V 1/8Hp, 1/4Hp, 1/2Hp
(1) DC Switching	0.005~0.015	0.005~0.02	0.005~0.015
(2) AC Switching(A)	0.03~0.10	0.05~0.15	0.03~0.10
(3) AC Switching(B)	0.10~0.20	0.20~0.40	0.10~0.20

### Water-Resist Type

Type	Motor Type
	Three Phase: 208/230/460V 1/8Hp, 1/4Hp, 1/2Hp, 3/4Hp, 1Hp
(1) DC Switching	0.005~0.015
(2) AC Switching(A)	0.03~0.13
(3) AC Switching(B)	0.10~0.30

## Brake Equipped Single Phase Motor: 1/8 Hp, Permanent Split Capacitor Type

	115V	220/230V
<b>DC Switching</b>		
<b>AC Switching(A)</b>	<p>The "blue" to "blue" in the rectifier corresponds to the short circuit.</p>	<p>The "blue" to "blue" in the rectifier corresponds to the short circuit.</p>
<b>AC Switching(B)</b>	<p>The "blue" to "blue" in the rectifier corresponds to the short circuit.</p>	<p>The "blue" to "blue" in the rectifier corresponds to the short circuit.</p>

MS:Electro-Magnetic Switch    C:Capacitor    -N-:Surge Suppressor (option)

## Brake Equipped Single Phase Motor: 1/4 Hp, 1/2 Hp, Capacitor Start type

	115V	220/230V
<b>DC Switching</b>		
<b>AC Switching(A)</b>	<p>The "blue" to "blue" in the rectifier corresponds to the short circuit.</p>	<p>The "blue" to "blue" in the rectifier corresponds to the short circuit.</p>
<b>AC Switching(B)</b>	<p>The "blue" to "blue" in the rectifier corresponds to the short circuit.</p>	<p>The "blue" to "blue" in the rectifier corresponds to the short circuit.</p>

-N-:Surge Suppressor (option)

# Brake Equipped Three Phase: 1/8 Hp, 1/4 Hp, 1/2 Hp, 3/4 Hp, 1 Hp, 2 Hp, 3 Hp

	208/230V	460V	Double Voltage (400V with Brake) ※ Brake (yellow lead wire)
DC Switching			
AC Switching(A)	<p>The "blue" to "blue" in the rectifier corresponds to the short circuit.</p>	<p>The "blue" to "blue" in the rectifier corresponds to the short circuit.</p>	<p>The "blue" to "blue" in the rectifier corresponds to the short circuit.</p>
AC Switching(B)	<p>The "blue" to "blue" in the rectifier corresponds to the short circuit.</p>	<p>The "blue" to "blue" in the rectifier corresponds to the short circuit.</p>	<p>The "blue" to "blue" in the rectifier corresponds to the short circuit.</p>

-N-: Surge Suppressor (option)

- Products with 9 leads and with capacities of 3/4Hp~3Hp will have a terminal box. The prints on the terminal will be different from the lead wire type, so please refer to the diagram below when wiring.

Lead Wire Type (1/8Hp, 1/4Hp, 1/2Hp)	Terminal Box Type (3/4Hp, 1Hp, 2Hp, 3Hp)

Note: If an inverter (VFD) is used, the brake rectifier cannot be powered using the output side of the inverter. Please see the special inverter (VFD) wiring diagrams. The above diagrams are not suitable.

## Info regarding stud type terminal box with integrated rectifier (custom-made)

	A: 208, 230V/60Hz L: 200, 200, 220V/50, 60, 60Hz	A: 460V/60Hz, 400V/50Hz ※400V with Brake
AC Switching(B)	<p>※Terminal B1 and B2 aren't used for AC Switching(B).</p>	<p>※Terminal B1 and B2 aren't used for AC Switching(B).</p>
DC Switching	<p>※Terminal B1 and B2 are the rectifier's DC Switching.</p>	<p>※Terminal B1 and B2 are the rectifier's DC Switching.</p>
AC Switching(A)	<p>※Terminal B1 and B2 are the rectifier's input.</p>	<p>※Terminal B1 and B2 are the rectifier's input.</p>

-N:-Surge Suppressor (option)

(Note) Please read “ 3 Wiring a Gearmotor with a Brake.”

### 4 Cautions for Operation with an Inverter (VFD)

- (1) Higher temperature rise, noise and vibration than that from the general power source will be observed. Especially, low speed rotation which naturally reduce the fan effect, may cause abnormal rise of temperature. (More than 80°C at the surface of the motor)
- (2) When driving a gearmotor equipped with a brake, the brake may malfunction due to voltage drop caused by normal operation of the inverter (VFD) if the rectifier is powered by the output side of the inverter (VFD). To avoid this, it is imperative to bypass the inverter when wiring the brake. See the special wiring diagrams for use with inverters (VFD) in this manual.
- (3) When using inverter in the 400V class motor, consult with inverter manufacturer concerning the micro surge voltage.
- (4) When using a 460V inverter with a brake, do not tap the motor windings to power the rectifier (T8-T5, T9-T6). Due to voltage drop caused by normal operation of the inverter (VFD), power from tapping the coil wires is not reliable and will result in brake failure. The rectifier (A200-D90) must be powered with a separate 200~230V 1 phase source. Alternatively, if the input power source is 115V, please consult brother for the purchase of a rectifier that accepts 115VAC and has an output of 90VDC (Ref P/N: A100-D90[A100-D45] rectifier). The A200-D90[A100-D45] rectifier is not suitable for 115V power.

## Wiring a Brake Equipped Gearmotor with an Inverter (VFD)

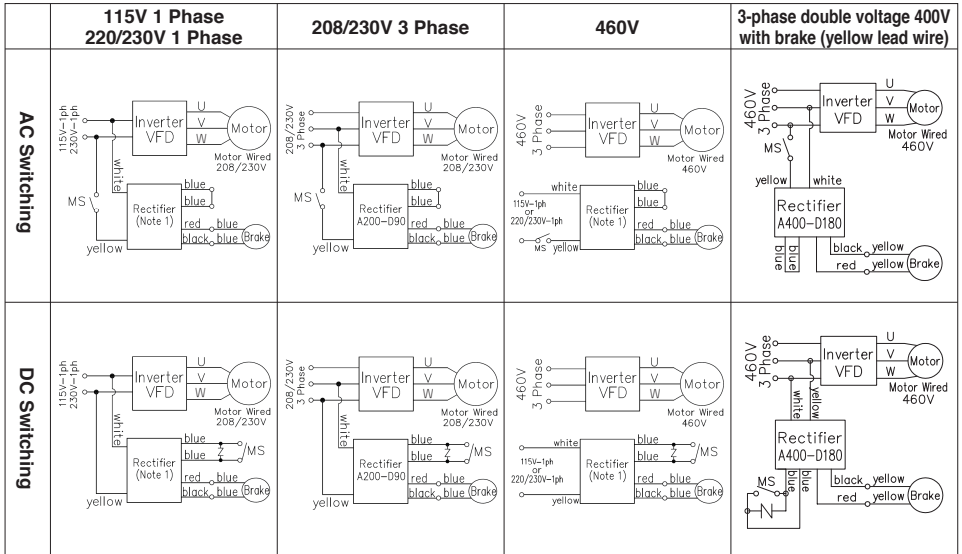

Note 1 : If the input power is 115V 1 phase, use Rectifier A100-D90. If the input power is 220/230V, use Rectifier A200-D90. (Input power to the brake is 90vdc)

MS: Magnetic Switch

Z: Surge Suppressor.

## Data of Inverter Motor with Allen Bradley (Power Flex 4)

Below is understanding of Limit curve when Allen Bradley Inverter (Power Flex 4) is used along with our gearmotor

When Frequency reaches 60Hz, load factor (%) is equal to the Output shaft torque 100% as defined in the catalogue

Based on Inverter features change, so in case if you use other inverters apart from Allen Bradley (Power Flex 4), Please contact our customer care for more information

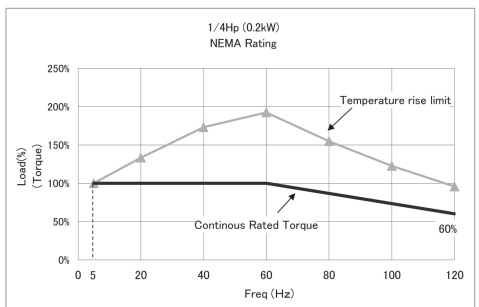
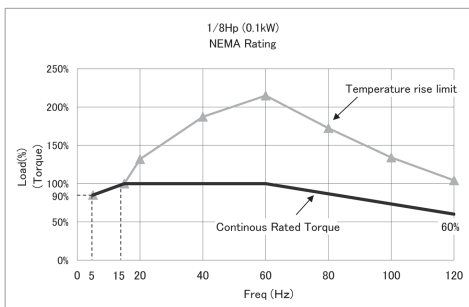

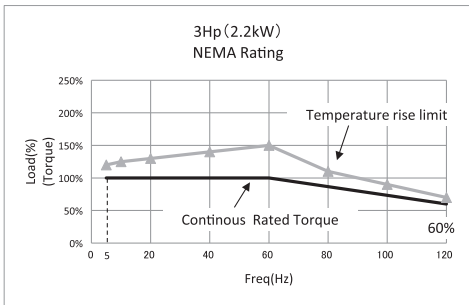
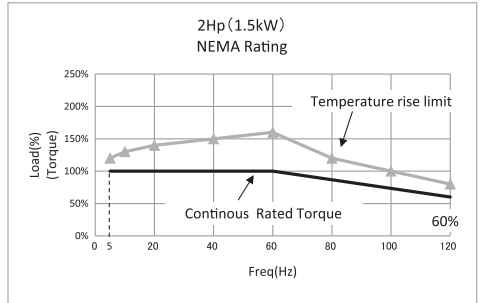
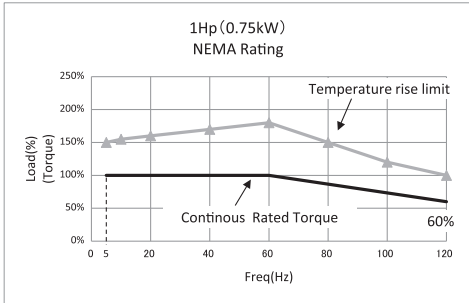
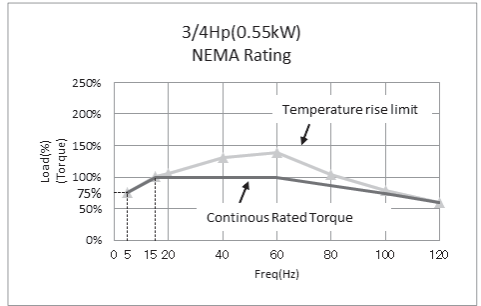
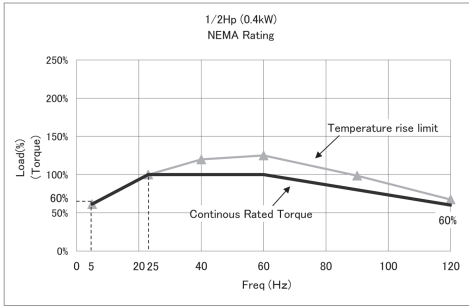

Remarks	Capacity						
	1/8Hp	1/4Hp	1/2Hp	3/4Hp	1Hp	2Hp	3Hp
① Freq (Hz)	5	5	5	5	5	5	5
① Torque (%)	90%	100%	60%	75%	100%	100%	100%
② Freq (Hz)	15	5	25	15	5	5	5
② Torque (%)	100%	100%	100%	100%	100%	100%	100%
③ Freq (Hz)	60	60	60	60	60	60	60
③ Torque (%)	100%	100%	100%	100%	100%	100%	100%
④ Freq (Hz)	120	120	120	120	120	120	120
④ Torque (%)	60%	60%	60%	60%	60%	60%	60%

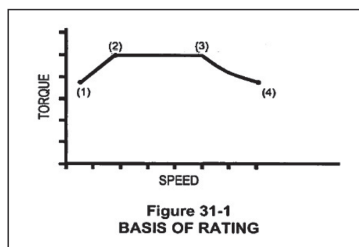

**NOTES**

- 1 = Torque at minimum speed based on temperature considerations and voltage boost
- 2 = Lowest speed of the constant torque range based on temperature considerations
- 3 = Base rating point at upper end of constant torque range
- 4 = Maximum operating speed based on constant horsepower and any limitation on rotational speed
- 5 = 3/4 Hp data is base on the use of 1 Hp Allen Bradley (Power Flex 4) inverter

## 7 Operation

### **Danger**

- Do not operate the gearmotor with the terminal box cover opened. Failure to observe this warning may cause electric shock.
- Do not approach or touch rotating parts such as a shaft while the machine is running. Failure to observe this warning may cause physical injury.
- If power loss occurs; switch off the power supply to the machine. Unexpected recovery of electric service may cause a sudden start of the gearmotor and cause physical injury and/or damage to the equipment.

### **Caution**

- The gearmotor may become hot during operation. Do not touch it with your bare hands. Failure to observe this warning may cause burn injury.
- When a gearmotor is running abnormal, stop it immediately. Failure to observe this warning may cause electric shock, physical injury or fire.
- Do not overload a gearmotor. Failure to observe this warning may cause physical injury and/or damage to the equipment.
- Do not touch any current-carrying part of the capacitor used for a single-phase motor until it has been discharged completely. Failure to observe this warning may cause electric shock.
- When reversing the direction of a single-phase motor, it must come to a complete rest before starting rotation in the opposite direction. If a single phase motor does not come to a complete stop before reversing, the direction of rotation may not change. Failure to stop the motor completely before reversing may cause physical injury or damage to the machine.
- Do not stop or stall a motor forcibly. It may cause damage to the machine.
- If a 1/8 Hp single phase, permanent split capacitor (PSC) motor is stalled forcibly, the motor may spontaneously rotate in the opposite direction. This may cause damage to the equipment or physical injury.

#### **1 Check these issues before turning the power switch on:**

- (1) Wiring and connections are done properly to required codes.
- (2) Fuses and thermal relays of proper capacity are used.
- (3) Installation and the connection with the machine is properly done.
- (4) The earth terminal, lead wire, or lug is properly grounded.

[Note] When using a water-resistant IP-65 motor in the circumstance where water may be persistently present during operation, it is recommended to use ground fault circuit interrupter for safety.

#### **2 Check these issues during the initial test run:**

- (1) Confirm the direction of rotation for 1~2 seconds by starting the motor in the unloaded condition. If you find improper rotational direction, change the wiring.
- (2) Test run the gearmotor with the machine in an unloaded condition. When no defect is observed, add load gradually and eventually start operation under the full load.

#### **3 Check these issues during operation:**

- (1) Confirm there is no abnormal noise and/or vibration. Stop operation of the gearmotor immediately if abnormal noise or vibration occurs. Failure to observe this warning may cause physical injury and/or damage to the equipment.
- (2) Confirm the surface temperature of the gear case and motor frame does not exceed 176F (80°C). Do not touch the surface of the gearmotor with your bare hands. Failure to observe this warning may cause a burn injury.

## 8 Inspection and Adjustment

### **Danger**

- When inspecting and/or adjusting the machine while it is in operation, do not touch rotating parts such as a shaft. Failure to observe this warning may cause physical injury.
- Do not attempt to disassemble the gearmotor while it is in operation. Lubricant may blow-out and cause a burn injury. Opening the motor may cause electric shock.
- If the gearmotor is enclosed inside the equipment and you need to inspect it, be sure to immobilize the gearmotor drive shaft and the machine drive shaft prior to inspection. Also, confirm the equipment is sufficiently cooled down before attempting any inspection.
- During any inspection, please have support personnel outside the machine to watch safety conditions. If lubricant has spilled it can be very slippery, please use caution. Failure to observe this warning may cause physical injury.
- Do not operate the equipment with safety guards off. Failure to observe this warning may cause physical injury.

#### [ Inspection and Maintenance of Brake Parts ]

- Do not operate the equipment with the manual release lever of a brake disengaged. Failure to observe this warning may cause damage to the equipment, physical injury, or death.
- Before starting the equipment, make sure the brake is functioning properly. Turn the switch on and off and listen for the “click” of the brake. Failure to observe this warning may cause malfunction of the machine, loss of brake function resulting in damage to the equipment, physical injury, or death.
- Do not operate the equipment without the fan cover ( or brake cover ) installed after inspection and adjustment of brake gap. Failure to observe this warning may cause wind-in and physical injury.
- Do not release the brake while the equipment is operating. Failure to observe this warning may cause the machine to run out of control, damage the equipment and result in physical injury or death.

### **Caution**

- When measuring the insulation resistance do not touch the terminals. Failure to observe this warning may cause electric shock.
- The surface of a gearmotor may be very hot. Do not touch it with your bare hands. Failure to observe this warning may cause burn injury.
- When abnormal operation is observed; diagnose the fault according to the instruction manual. Do not operate the machine until the cause of the fault is found and proper measures are taken to correct the matter.
- When measuring the insulation resistance of an explosion-proof type motor, confirm that there is no gas, vapor, or other explosive substance around the unit. Failure to observe this warning may cause an explosion or ignition.
- Repairing, disassembling and reassembling of the equipment should be done only by an experienced technician. Failure to observe this warning may cause electric shock, physical injury or fire.
- Improper disassembly of the gearmotor voids the warranty.



**1 Daily Inspection: Following items should be inspected every few days.**

Inspection item	Interval	Details of Inspection
Load Current	Ammeter	Compare it to the full load current on nameplate.
Noise	Human Ear Detection Rod	No abnormal rumbling, grinding, clicking, or ticking sound
Vibration	Touch (please wear a protective gloves)	No abnormal vibration on gear case or motor.
Surface Temperature	Thermometer	Less then 176°F (80°C)
Grease Leakage	Visual	No lubricant leaking from the casing joints, rotor fan extension, terminal box, lead wire grommet, cord exit, or output shaft seal.

**2 Periodic Inspections: (In case of operating 8 hours a day)**

Inspection item	Interval	Details of Inspection
Fixing Bolt	6 months	Check to see if the bolt is loose. Retighten if required.
Chain or V-belt	6 months	Check tension (loose or tight) and adjust to proper tension.
Insulation Resistance of Motor	6 months	More than 1MΩ when insulation resistors is 500V.
Brake Gap	1 Year or 1~1.5 Million Cycles	Check if the gap is within the allowable limit. Refer to next Page. Adjust as instructed.
Brake Friction Disk	1 Year	Check the thickness of the friction disk. Replace if the disk is less than 1.5 mm. Consult Brother or your brother dealer for a replacement friction disk.

**3 Brake Gap “g” Adjustment for a Brake Equipped Gearmotor**

⚠	Danger
<p>1 When adjusting the gap disconnect the motor from the power source. Failure to observe this warning may cause physical injury.</p> <p>2 After inspection and adjustment of the gap, be sure to confirm the brake functions properly. Failure to observe this warning may cause an accident or allow the machine to run out of control.</p> <p>3 After inspection and adjustment of the gap, do not operate the motor with the fan cover (or brake cover) open. Failure to observe this warning may cause physical injury.</p>	

**Note: Brake Gap “g” Adjustment**

After operation for an extended period of time, the friction disk of the brake wears and the gap (g) increases. When the gap clearance becomes too large the armature cannot function and the brake will become ineffective or fail. Continuous usage of a brake when the gap is out of specification causes excessive temperature rise in the brake coil and will lead to coil failure. For safe operation, the brake gap should be inspected every 12 months or 1~1.5 Million cycles.

**Standard Motor:**

**Procedure for Brake Gap “g” Adjustment**

- ① Remove fan cover.
- ② Lift the tooth of the castellated nut from the securing slot. Also, loosen the set screw for single phase motors.
- ③ Press down the friction disk and tighten the castellated nut by hand until it is firmly locked.
- ④ Then, turn back the nut to the loosening direction at about 100°~180°. In the event of the castellated nut is removed, be sure to attach it in the right direction. (Refer to the figure on the right, which shows the attaching direction of the castellated nut.) And confirm if the gap clearance is proper, by using gap gauge.
- ⑤ Press the tooth of the castellated nut into the nearest slot on the friction disk. For single phase motors, secure setscrew as well.
- ⑥ Install the fan cover.

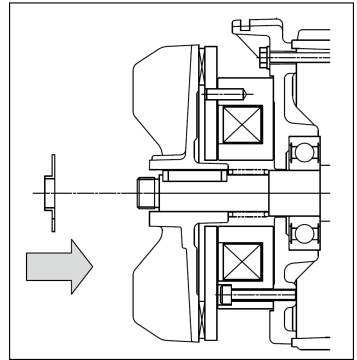

Attaching direction of the castellated nut.

[Note] Do not allow grease or dust to adhere to the friction disc. Failure to observe this warning will cause a decrease in braking performance.

**Motor: 1/8 Hp, 1/4 Hp, 1/2 Hp, 3/4 Hp, 1 Hp**

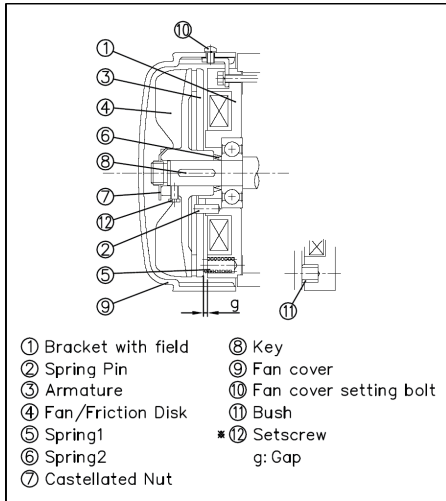

**Motor: 2 Hp, 3 Hp**

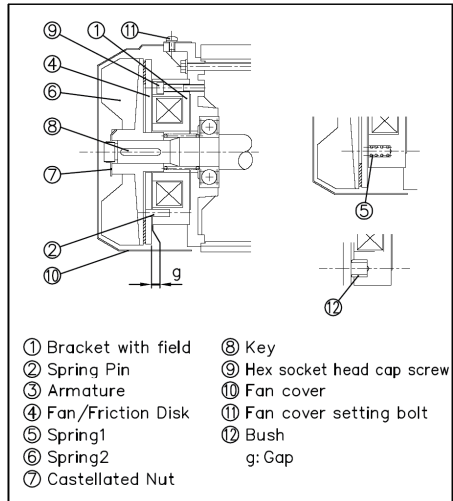

Set Screw ⑫ is only for 1 phase motors

**Gap “g” Data: Standard Motors**

Motor Horsepower / Type		Allowable Gap “g” (mm)	Proper Gap “g” (mm)
Three Phase	Single Phase		
1/8 Hp, 1/4 Hp	1/8 Hp, 1/4 Hp	less than 2.3	1.9 +/- 0.1
1/2 Hp	n/a	less than 1.8	1.4 +/- 0.1
3/4 Hp, 1 Hp	1/2 Hp	less than 2.4	2.0 +/- 0.1
2 Hp, 3 Hp	n/a	less than 1.0	0.4 +/- 0.1

**Water resistant IP-65 Motor:  
Procedure for Brake Gap “g” Adjustment**

- ① Remove the fan cover in the case of a fan cooled model. Then, remove the fan. Then, remove the brake cover. In the case of a 1/8 Hp non-vented unit (no fan), start by removing the brake cover.
- ② Lift the tooth of the castellated nut from the securing slot.
- ③ Press down on the friction disk and tighten the castellated nut by hand until it is firmly locked.
- ④ Then, turn back the nut to the loosening direction at about  $100^{\circ} \sim 180^{\circ}$ . In the event of the castellated nut is removed, be sure to attach it in the right direction. (Refer to the figure on the right, which shows the attaching direction of the castellated nut.) And confirm if the gap clearance is proper, by using gap gauge.
- ⑤ Press the tooth of the castellated nut into the nearest slot on the friction disk.
- ⑥ Install the brake cover. Check if there is any damage in the “o” ring of the brake cover before installation. If damage exists, replace it with new one.
- ⑦ Replace the brake cover after confirming the grease is properly applied in the oil seal. (Add grease if it is not sufficient.) (An oil seal is used with 1/4~1Hp.)
- ⑧ Check if there is any damage to the lip part of V seal. (If damage exist, replace it with new one). Also check if the grease is properly applied on the inside of lip part. (Apply grease if it is not sufficient.) Set up the lip part toward the brake cover side. (1/4~1Hp)
- ⑨ Replace the fan with hex socket head setting bolt. (1/4~1Hp)
- ⑩ Replace the fan cover. (1/4~1Hp)

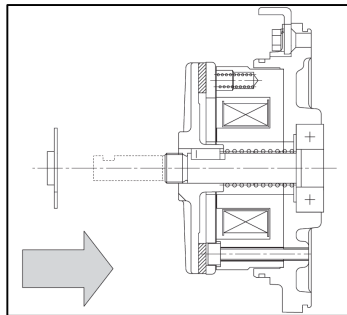

Attaching direction of the castellated nut.

[Note] Do not allow grease or dust to adhere to the friction disc. Failure to observe this warning will cause a decrease in braking performance.

**Motor: 1/8 Hp**

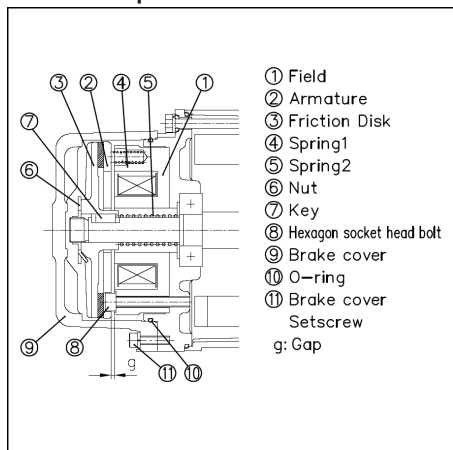

**Motor: 1/4 Hp, 1/2 Hp, 3/4 Hp, 1 Hp**

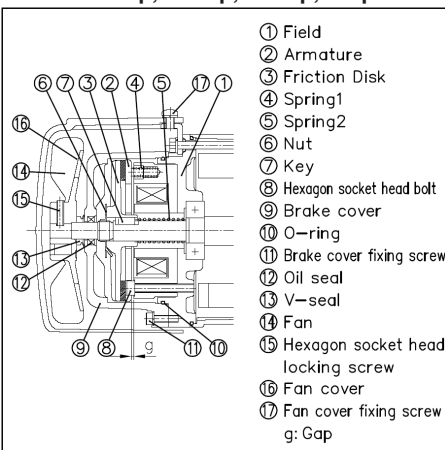

**Gap “g” Data: water resistant IP-65 Motors**

Three Phase Motor Horsepower	Allowable Gap “g” (mm)	Proper Gap “g” (mm)
1/8 Hp	less than 0.8	0.30 +/- 0.1
1/4 Hp, 1/2 Hp	less than 0.7	0.30 +/- 0.1
3/4 Hp, 1 Hp	less than 0.9	0.30 +/- 0.1

## 4 Warning Label

A warning label is attached to a gearmotor equipped with a brake that has a manual release lever. If the label peels off or becomes hard to read, contact Brother or your brother distributor for a replacement label.

## 5 Grease, Oil seal and O-Ring

- (1) All of our gearmotors employ grease lubrication. They are filled with a determined quantity of lubricant before shipping from our factory.
- (2) Replacement or refill of the lubricant is not necessary. However, replacing it once every 10,000 hours may help prolong the life of the reducer. If you need to replace the lubricant, be sure to use factory authorized grease and consider using our facility in the USA.
- (3) Our machines are protected from grease leakage by an oil seal and/or o-ring. While our sealing is reliable, it is recommended to protect the machine with an oil pan for safety. (Grease leakage may be observed when the machine is in trouble or at the end of a long life.)
- (4) The life of the oil seal will vary according to the condition of use. Therefore replacement under severe conditions may be needed within 10,000 hours of use. If you need to replace the oil seal, be sure to use a factory authorized part. Repair service from the factory is available as well.

# 9 Troubleshooting

## 1 Trouble Shooting a Gearmotor (no brake)

Trouble	Cause	Trouble Shooting
Motor Does Not Run, in the Unloaded Condition	Failure of Power Supply	Check the Power Source
	Bad Wire Connections	Check the Electric Circuit
	Failed Contact Switch	Repair / Replace the Relay
	Disconnected Stator Coil	Repair at Auth Facility
	3-phase Motor Running 1-phase	Check the Terminal Voltage
	Capacitor Not Connected (1/8 Hp 1 Phase)	Connect the Capacitor
	Governor Switch Malfunction(1/4, 1/2 Hp 1 Phase)	Repair at Auth Facility
	Broken Gear, Shaft, Bearing	Repair at Auth Facility
Motor Does Not Run in the Loaded Condition	Voltage Drop	Check the Length of Wire
	Worn Out Gear	Repair at Auth Facility
	Overload Tripped	Reduce the Load
Abnormal Temperature	Overload Tripped	Reduce the Load
	High Frequency of Starts/Stops	Reduce the Freq of Starts/Stops
	Damage to Bearings	Repair at Auth Facility
	Overvoltage or Undervoltage	Check the Voltage
Abnormal Noise	Defective Bearing or Worn Out Gear	Repair at Auth Facility
	Intermittent Noise-damaged Gear or Foreign Substance in the Gearbox	Repair at Auth Facility
Excessive Vibration	Worn Out Gear or Bearing	Repair at Auth Facility
	Improper Installation or Loose Bolts	Tighten the Bolts
Grease Leakage	Loose Bolts, Nuts, or Screws	Tighten the Bolts, Nuts, or Screws
	Damaged Oil seal	Repair at Auth Facility

## 2 Trouble Shooting a Gearmotor with a Brake

Trouble	Cause	Trouble Shooting
Brake Does Not Work	Incorrect Wiring	Check the Wiring
	Damaged Switch or Rectifier	Replace/Repair
Hold Torque Inadequate Brake Takes Too Long to Activate	Foreign Substance or Oil on Friction Disk	Remove Foreign Substance and/or Clean off the Oil
	Friction Disk Worn out (Thickness Less than 1.5 mm 1/17 in)	Replace the Friction Disk
	Excessive Load Inertia	Reduce the Load Inertia
	AC Switching Used	Change to DC Switching
Motor Does Not Run Motor Overheats, Trips Thermal Abnormal Brake Noise	Wiring Incorrect	Correct the Wiring
	Brake Gap "g" Too Large	Adjust the Brake Gap or Replace Friction Disk.
	Rectifier Failed	Replace the Rectifier
	Brake Coils Disconnected or Shorted	Replace the Coil
	Damaged Contact Switch	Repair or Replace the Switch
Excessive Temperature	High Frequency of Braking (Stops/Min)	Reduce the Brake Frequency (Fewer Stops/Min)
	Excessive Load or Load Inertia	Reduce the Load or Load Inertia

## 3 Parts for Replacement/Repair

Contact Brother or your Brother distributor for the replacement brake parts. Please note that we will not warrant any defect caused by improper replacement or repair completed by the user.

## 10 Disposal



### Caution

Gearmotors and lubricant should be disposed of as general industrial waste.

# 11 UL/CSA/CE

## 1 UL/CSA Information

Hp Range Phase	Voltage	UL Standard	UL File No.
1/8 Hp Single Phase	115V 60Hz 220V 60Hz 230V 60Hz	UL1004-1 : Standard for Safety, Rotating Electrical Machines-General Requirement  UL1004-3 : Standard for Safety, Thermally Protected Motors	E153713
1/4Hp, 1/2 Hp Single Phase	115V 60Hz 220V 60Hz 230V 60Hz	UL1004-1 : Standard for Safety, Rotating Electrical Machines-General Requirement	E172017
1/8 Hp ~ 3 Hp Three Phase	208V/230V/460V 60Hz	UL1004-1 : Standard for Safety, Rotating Electrical Machines-General Requirement	E172017

Brother Gearmotors have the UL Component Recognition mark on the nameplate.  
Brother Gearmotors have the cUL Component Recognition for Canada mark on the nameplate.

## 2 CE Information

Hp Range Phase	Voltage	Standards
1/8 Hp ~ 1/2 Hp Single Phase	115V 60Hz 220V 60Hz 230V 60Hz	EU Directive: 2014/35/EU (Low Voltage Directive)  EN Standard: EN60034-1 (Regulations on Motors in General)
1/8 Hp ~ 3 Hp Three Phase	208V/230V/460V 60Hz	

Brother Gearmotors have the “CE” mark on the nameplate.  
Please consult Brother for Technical File Information or a Formal Declaration of Conformity.

# 12 Standard Terms and Conditions of Sale

## General

These standard Terms and Conditions of Sale shall be incorporated into any contract between Purchaser and Brother International Corporation (hereafter Brother) and shall apply to all purchase orders issued by Purchaser. Unless specifically provided herein or in a separate written agreement duly executed by Brother, the quotation and this form constitute the entire agreement between Brother and Purchaser and no other terms or conditions oral or written shall be of any effect. All orders, whether placed pursuant to a quotation or not, are accepted only upon express condition that purchaser agrees to the Terms and Conditions as specified herein.

## Price and Delivery Terms

Price and delivery terms are F.O.B. Brothers nearest U.S. facility and do not include sales, use, excise, or any other taxes. Our responsibility ceases when delivery is made to the transportation company and any claims for loss or damage in transit must be handled by the Purchaser with the carrier.

## Packing

No charge is made for standard boxing for domestic shipments. Purchaser will be quoted and charged separately for export or special packing requirements.

## Payment Terms

To Purchasers with credit standing satisfactory to Brother, terms of payment are cash in full, net 30 days. If at any time Brother deems that by reason of financial condition of the Purchaser or otherwise, the continuance of production or shipments is not justified, Brother may revoke its extension of credit, enforce any security interest(s) created hereby on all goods furnished by Brother to the Purchaser and otherwise secure itself as to Purchasers performance of its obligation.

## Cancellation

Changes, suspension or cancellation of any order by Purchaser may be made only upon written approval of an authorized officer of Brother.

## Warranty

All Brother gearmotor product are warranted against defects in materials and workmanship for a period of 2 years from the date of manufacture. This constitutes Brother's only warranty in connection with this sale, and is in lieu of all other warranties expressed or implied, written or oral. There are no implied warranties of merchantability or fitness for a particular purpose that apply to this sale. If performance guarantees are requested, they should be requested in writing. Full consideration will be given to such requests when complete details of the proposed application are included.

## Limitation of Remedy

Brother will repair or replace, at brother's option, F.O.B. Brother's factory, freight prepaid, any Brother gearmotor proved defective in materials or workmanship if immediate written notice of claim is made to Brother by Purchaser within 2 years from the date of manufacture. It is agreed that such repair or replacement is the exclusive remedy available from Brother. Under no circumstances shall Brother be liable to anyone for any special, incidental or consequential damages, whether the result of negligence or otherwise.

## Warranty Exclusions

The Warranty of Brother gearmotor products does not cover and Brother makes no warranty with respect to:

1. Failures not reported in writing to Brother within the warranty period of 2 years after the date of manufacture.
2. Failures or damages due to miss-application, abuse, improper installation or abnormal conditions of temperature, humidity, dirt or corrosive matter.
3. Failures due to operation, either intentional or otherwise, above rated capacities or in an otherwise improper manner.
4. Product which has in any way been tampered with or altered by anyone other than an authorized representative of Brother.
5. Expenses incurred by the Purchaser in an attempt to repair or rework an allegedly defective product.
6. Product damaged in shipment or otherwise without the fault of Brother.

## Returns

No product will be accepted for return unless authorized in writing with a returned merchandise authorization (RMA) number assigned. Any returned goods must be returned with transportation charges prepaid.

## Regulatory Laws and/or Standards

It is the Purchaser's obligation to install and operate all Brother gearmotor products in conformance with all applicable national or local laws and safety codes.

## Patents

Brother represents that its gearmotors are designed and manufactured such that they do not infringe on any United States Patent(s), and that Brother will, at its expense, defend any claim charging such infringement and will save Purchaser harmless from any adverse judgements resulting there from. Purchaser agrees to give Brother, prompt written notice of any claim of infringement and to turn over to Brother the complete control of any litigation involving such claims including the right to settle such claims. This indemnity does not apply to Products which are incorporated by the Purchaser into Products which are changed to infringe a Patent or to Product which is used by Purchaser in performance of a method or process which is charged to infringe a Patent.

## Law

These Standard terms and Conditions of Sale shall be interpreted in accordance with the Laws of the State of New Jersey.

## Severability

If any of the terms and Conditions shown here are determined to be invalid, illegal, or unenforceable the remainder of these Terms and Conditions shall remain in full force and effect.

**BROTHER INTERNATIONAL CORPORATION  
GEARMOTOR DIVISION**

200 Crossing Boulevard, Bridgewater, NJ 08807

Phone: 866-523-6283 Fax: 908-575-3743

E-mail: [garmotors@brother.com](mailto:garmotors@brother.com) , [www.BrotherGearmotors.com](http://www.BrotherGearmotors.com)