

BAS-326H-484 BAS-326H-484 SF

取扱説明書・基本編
Basic Operation Manual
使用说明书・基本篇
Manual básico de operación

ダイレクトドライブ プログラム式電子ミシン<全回転3倍がま仕様>

この説明書を読んでから、製品をご使用ください。

この説明書は、必要なときにすぐに取り出せる場所に、保管してください。

- * この「取扱説明書・基本編」には、ミシンの操作までの基本的な内容が記述されています。お手入れや標準調整など、更に詳しい内容は、「ダウンロード版」の取扱説明書をご覧ください。

DIRECT DRIVE PROGRAMMABLE ELECTRONIC PATTERN SEWER <TREBLE HOOK>

Please read this manual before using the machine.

Please keep this manual within easy reach for quick reference.

- * This basic operation manual describes basic operations including sewing machine operations. For cleaning, standard adjustments and more details, please refer to the instruction manual contained in the download version of the Instruction Manual.

直接駆動式

程序电脑花式机<三倍大旋梭>

在使用缝纫机之前请先阅读本使用说明书。

请将本使用说明书放在便于查阅的地方保管。

- * 本「使用说明书・基本篇」，主要记述了有关缝纫机操作的基本内容。保养、标准调整等详细内容，请浏览下载版的使用说明书。

MOTOR INCORPORADO AL EJE MÁQUINA ELECTRÓNICA DE ÁREA PROGRAMABLE <GARFIO MEDIO>

Por favor lea este manual antes de usar la máquina.

Por favor guarde este manual al alcance de la mano para una rápida referencia.

- * Este manual básico de operación describe las operaciones básicas de la máquina de coser. Para limpiar, realizar ajustes estándar y otros detalles, consulte el manual de instrucciones de la versión de descarga.

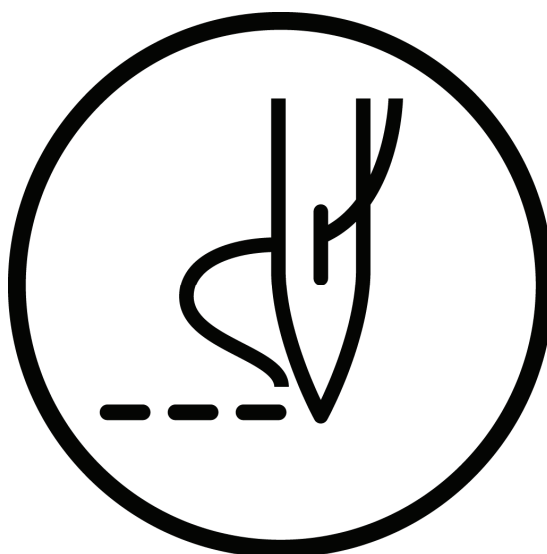

brother

BAS-326H-484 **BAS-326H-484 SF**

DIRECT DRIVE
PROGRAMMABLE ELECTRONIC PATTERN SEWER
<TREBLE HOOK>

Thank you very much for buying a BROTHER sewing machine. Before using your new machine, please read the safety instructions below and the explanations given in the instruction manual.

With industrial sewing machines, it is normal to carry out work while positioned directly in front of moving parts such as the needle and thread take-up lever, and consequently there is always a danger of injury that can be caused by these parts. Follow the instructions from training personnel and instructors regarding safe and correct operation before operating the machine so that you will know how to use it correctly.



SAFETY INSTRUCTIONS

[1] Safety indications and their meanings

This instruction manual and the indications and symbols that are used on the machine itself are provided in order to ensure safe operation of this machine and to prevent accidents and injury to yourself or other people.

The meanings of these indications and symbols are given below.

Indications

 DANGER	The instructions which follow this term indicate situations where failure to follow the instructions will result in death or serious injury.
 WARNING	The instructions which follow this term indicate situations where failure to follow the instructions could result in death or serious injury.
 CAUTION	The instructions which follow this term indicate situations where failure to follow the instructions may result in minor or moderate injury.

Symbols



..... This symbol (\triangle) indicates something that you should be careful of. The picture inside the triangle indicates the nature of the caution that must be taken.
(For example, the symbol at left means "beware of injury".)



..... This symbol (\circ) indicates something that you must not do.



..... This symbol (\bullet) indicates something that you must do. The picture inside the circle indicates the nature of the thing that must be done.
(For example, the symbol at left means "you must make the ground connection".)

[2] Notes on safety

DANGER



Wait at least 5 minutes after turning off the power switch and disconnecting the power cord from the wall outlet before opening the control box cover. Touching areas where high voltages are present can result in severe injury.

WARNING



Do not allow any liquids to get onto this sewing machine, otherwise fire, electric shocks or operating problems may occur.



If any liquid gets inside the sewing machine (machine head or control box), immediately turn off the power and disconnect the power plug from the electrical outlet, and then contact the place of purchase or a qualified technician.

CAUTION

Environmental requirements



Use the sewing machine in an area which is free from sources of strong electrical noise such as electrical line noise or static electric noise.

Sources of strong electrical noise may cause problems with correct operation.



Any fluctuations in the power supply voltage should be within $\pm 10\%$ of the rated voltage for the machine. Voltage fluctuations which are greater than this may cause problems with correct operation.



The power supply capacity should be greater than the requirements for the sewing machine's power consumption.

Insufficient power supply capacity may cause problems with correct operation.



Do not connect anything to the USB port other than the USB memory. If this is not observed, problems with operation may result.



The pneumatic delivery capability should be greater than the requirements for the sewing machine's total air consumption.

Insufficient pneumatic delivery capability may cause problems with correct operation.



The ambient temperature should be within the range of 5°C to 35°C during use.

Temperatures which are lower or higher than this may cause problems with correct operation.



The relative humidity should be within the range of 45% to 85% during use, and no dew formation should occur in any devices.

Excessively dry or humid environments and dew formation may cause problems with correct operation.



In the event of an electrical storm, turn off the power and disconnect the power cord from the wall outlet. Lightning may cause problems with correct operation.

Installation



Machine installation should only be carried out by a qualified technician.



Contact your Brother dealer or a qualified electrician for any electrical work that may need to be done.



The sewing machine weighs approximately 88 kg. The installation should be carried out by three or more people.



Do not connect the power cord until installation is complete. If the foot switch is depressed by mistake, the sewing machine might start operating and injury could result.



Hold the machine head with both hands when tilting it back or returning it to its original position.

Furthermore, do not apply excessive force when tilting back the machine head. The sewing machine may become unbalanced and fall down, and serious injury or damage to the sewing machine may result.



Be sure to connect the ground. If the ground connection is not secure, you run a high risk of receiving a serious electric shock, and problems with correct operation may also occur.



All cords should be secured at least 25 mm away from any moving parts. Furthermore, do not excessively bend the cords or secure them too firmly with staples, otherwise there is the danger that fire or electric shocks could occur.



Install the safety covers to the machine head and motor.



If using a work table which has casters, the casters should be secured in such a way so that they cannot move.













Be sure to wear protective goggles and gloves when handling the lubricating oil and grease, so that they do not get into your eyes or onto your skin. If the oil and grease get into your eyes or onto your skin, inflammation can result.

Furthermore, do not drink or eat the lubricating oil or grease. They may cause diarrhea or vomiting.



Keep the oil out of the reach of children.

CAUTION









Sewing

-  To prevent problems, do not use objects with sharp points to operate the LCD panel.
-  This sewing machine should only be used by operators who have received the necessary training in safe use beforehand.
-  The sewing machine should not be used for any applications other than sewing.
-  Be sure to wear protective goggles when using the machine.
If goggles are not worn, there is the danger that if a needle breaks, parts of the broken needle may enter your eyes and injury may result.
-  Turn off the power switch at the following times. If the foot switch is depressed by mistake, the sewing machine might start operating and injury could result.
 - When replacing the bobbin and needle
 - When not using the machine and when leaving the machine unattended
-  If using a work table which has casters, the casters should be secured in such a way so that they cannot move.
-  Attach all safety devices before using the sewing machine. If the machine is used without these devices attached, injury may result.
-  Do not touch any of the moving parts or press any objects against the machine while sewing, as this may result in personal injury or damage to the machine.
-  If an error occurs in machine operation, or if abnormal noises or smells are noticed, immediately turn off the power switch. Then contact your nearest Brother dealer or a qualified technician.
-  If the machine develops a problem, contact your nearest Brother dealer or a qualified technician.

Cleaning

-  Turn off the power switch before carrying out cleaning. If the foot switch is depressed by mistake, the sewing machine might start operating and injury could result.
-  Be sure to wear protective goggles and gloves when handling the lubricating oil and grease, so that they do not get into your eyes or onto your skin. If the oil and grease get into your eyes or onto your skin, inflammation can result.
Furthermore, do not drink or eat the lubricating oil or grease. They may cause diarrhea or vomiting.
Keep the oil out of the reach of children.

Maintenance and inspection

-  Maintenance and inspection of the sewing machine should only be carried out by a qualified technician.
-  Ask your Brother dealer or a qualified electrician to carry out any maintenance and inspection of the electrical system.
-  Turn off the power switch and disconnect the power cord before carrying out the following operations. If the foot switch is depressed by mistake, the sewing machine might start operating and injury could result.
 - Inspection, adjustment and maintenance
 - Replacing consumable parts such as the rotary hook
-  Disconnect the air hoses from the air supply and wait for the needle on the pressure gauge to drop to "0" before carrying out inspection, adjustment and repair of any parts which use the pneumatic equipment.
-  Hold the machine head with both hands when tilting it back or returning it to its original position.
Furthermore, do not apply excessive force when tilting back the machine head. The sewing machine may become unbalanced and fall down, and serious injury or damage to the sewing machine may result.
-  If the power switch needs to be left on when carrying out some adjustment, be extremely careful to observe all safety precautions.
-  When replacing parts and installing optional accessories, be sure to use only genuine Brother parts.
Brother will not be held responsible for any accidents or problems resulting from the use of non-genuine parts.
-  If any safety devices have been removed, be absolutely sure to re-install them to their original positions and check that they operate correctly before using the machine.
-  To prevent accidents and problems, do not modify the machine yourself.
Brother will not be held responsible for any accidents or problems resulting from modifications made to the machine.

[3] Warning labels

The following warning labels appear on the sewing machine.

Please follow the instructions on the labels at all times when using the machine. If the labels have been removed or are difficult to read, please contact your nearest Brother dealer.

1		▲ 危険		▲ 危険	
		高電圧部分にふれて、大けがをすることがある。 電源を切り、5分たってからカバーをはずすこと。		触摸高压电部分，会导致受伤。 在切断电源5分钟后，再开启盖罩。	
	▲ DANGER	▲ GEFAHR	▲ DANGER	▲ PELIGRO	
	Hazardous voltage will cause injury. Turn off main switch and wait 5 minutes before opening this cover.	Hochspannung verletzungsgefahr! Bitte schalten sie den hauptschalter aus und warten sie 5 minuten, bevor sie diese abdeckung öffnen.	Un voltage non adapte provoque des blessures. Eteindre l'interrupteur et attendre 5 minutes avant d'ouvrir le capot.	Un voltaje inadecuado puede provocar las heridas. Apagar el interruptor principal y esperar 5 minutos antes de abrir esta cubierta.	

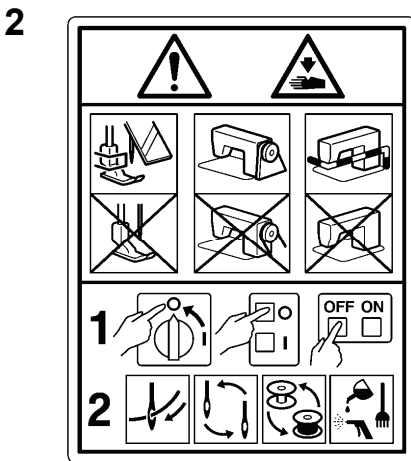



CAUTION
Moving parts may cause injury.

Operate with safety devices* installed.

*Safety devices
Devices such as eye guard, finger guard, thread take-up cover, side cover, rear cover, solenoid cover, inner cover, outer cover, fixed cover and gas spring support cover

Turn off the power before carrying out operations such as threading, changing the needle, bobbin, knives or hook, cleaning and adjusting.

3  Be careful not to get your hand caught when tilting back the machine head and returning it to its original position.

4  Be sure to connect the ground. If the ground connection is not secure, you run a high risk of receiving a serious electric shock, and problems with correct operation may also occur.

5  Direction of operation

6  Be careful to avoid injury from moving parts.

7  Do not hold, otherwise problems with operation or injury may occur.

8

brother
Lubricating Oil for Machining

▲ CAUTION

Lubricating oil may cause inflammation to eye and skin.
Wear protective glasses and gloves.

Swallowing oil can cause diarrhoea and vomiting.
Do not swallow.

Keep away from children.
FIRST AID
Eye contact :
-Rinse with plenty of cold water.
-Seek medical help.
Skin contact :
-Wash with soap and water.
If swallowed :
-Seek medical help immediately.

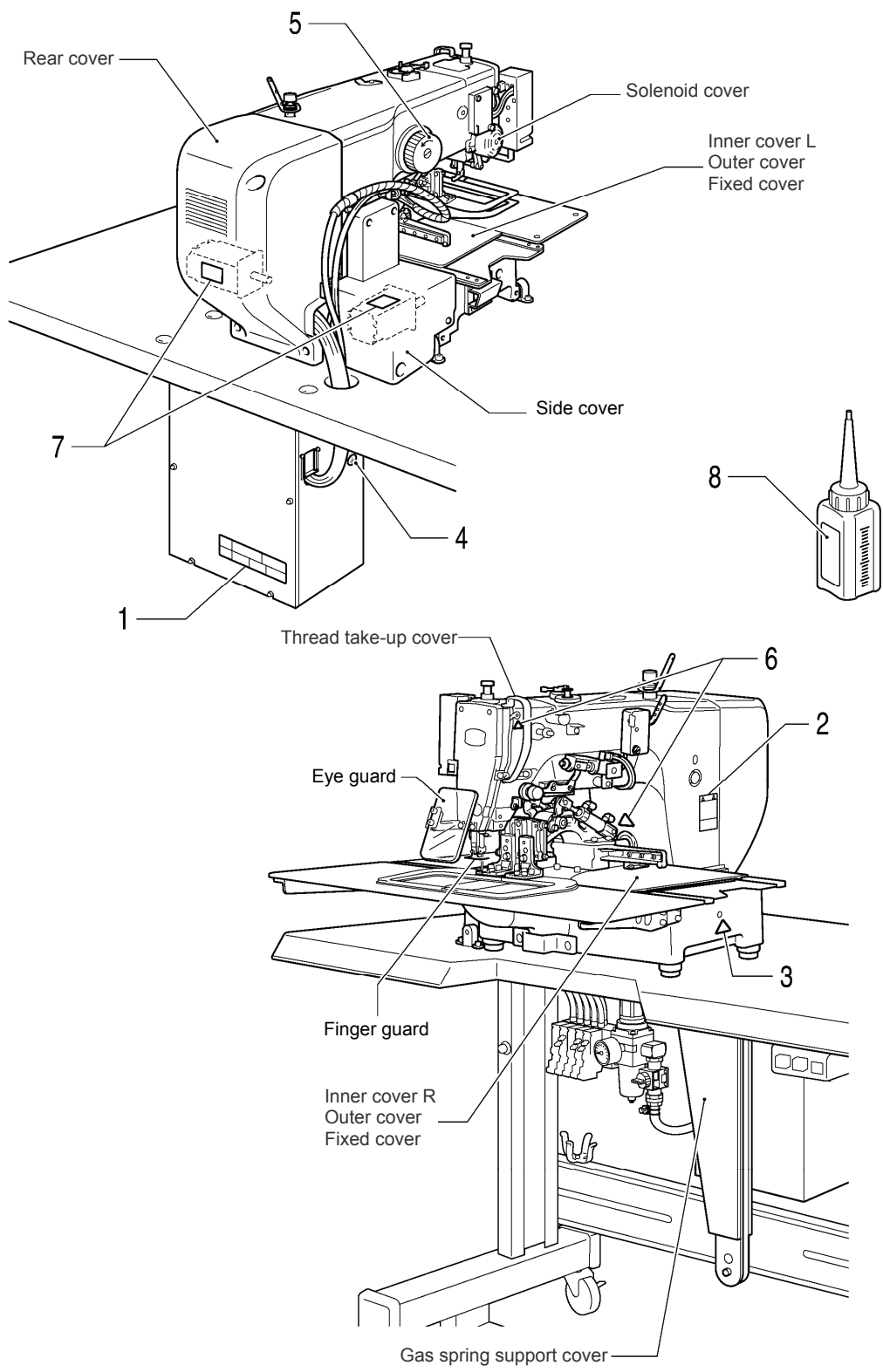

3687B

CONTENTS

1. NAMES OF MAJOR PARTS	1	5. USING THE OPERATION PANEL	
2. USEFUL FUNCTIONS FOR		(BASIC OPERATIONS)	30
OPTIMUM SEWING.....	2	5-1. Name and function of each LCD panel item	30
3. INSTALLATION	3	5-1-1. Main names and functions	30
3-1. Table processing diagram	3	5-1-2. Home screen.....	30
3-2. Installing the control box.....	4	5-1-3. Sewing operation screen	31
3-3. Installing the oil pan.....	4	5-2. Parameter setting method.....	32
3-4. Installing the machine head.....	5	5-3. Copying programs.....	35
3-5. Installing the LCD panel	8	5-4. Checking the sewing pattern.....	36
3-6. Installing the two-pedal foot switch	9	5-5. Setting the intermittent presser foot lift amount	
3-7. Connecting the cords.....	9	(BAS-326H-484 SF specifications only)	37
3-8. Connecting the ground wire.....	13	6. USING STORAGE MEDIA	39
3-9. Connecting the power cord.....	14	6-1. Notes on handling	39
3-10. Installing the cotton stand.....	17	6-2. Importing and exporting data	39
3-11. Installing the pneumatic unit.....	18	6-3. Importing items of sewing data separately	41
3-12. Adjusting the speed controller	19	7. SEWING	42
3-13. Installing the eye guard	20	7-1. Sewing	42
3-14. Installing the side cover and rear cover.....	20	7-2. Using the STOP switch	43
3-15. Lubrication	21		
3-16. Installing the machine head fixing bolt	22		
3-17. Checking the machine head switch.....	22		
4. PREPARATION BEFORE SEWING.....	23		
4-1. Installing the needle.....	23		
4-2. Threading the upper thread	24		
4-3. Winding the lower thread.....	26		
4-4. Installing the bobbin case	27		
4-5. Installing the anti-spin spring	28		
4-6. Thread tension.....	28		
4-6-1. Lower thread tension.....	28		
4-6-2. Upper thread tension	29		
4-7. Starting up	29		

1. NAMES OF MAJOR PARTS

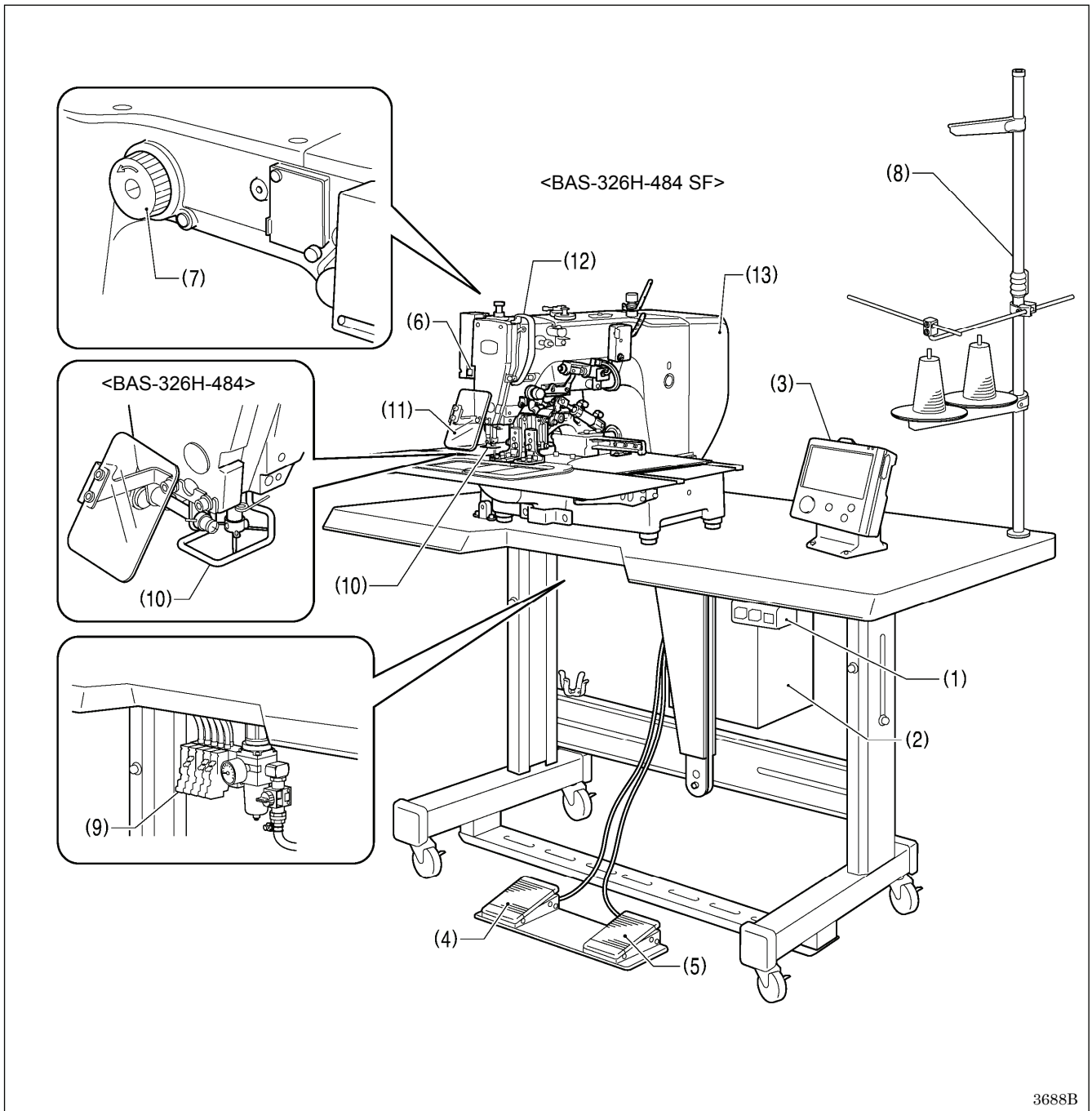

3688B

- (1) Power switch
- (2) Control box
- (3) LCD panel
- (4) Work clamp switch
- (5) Start switch
- (6) STOP switch
- (7) Pulley
- (8) Cotton stand
- (9) Solenoid valve

- Safety devices:**
- (10) Finger guard
 - (11) Eye guard
 - (12) Thread take-up cover
 - (13) Rear cover

2. USEFUL FUNCTIONS FOR OPTIMUM SEWING

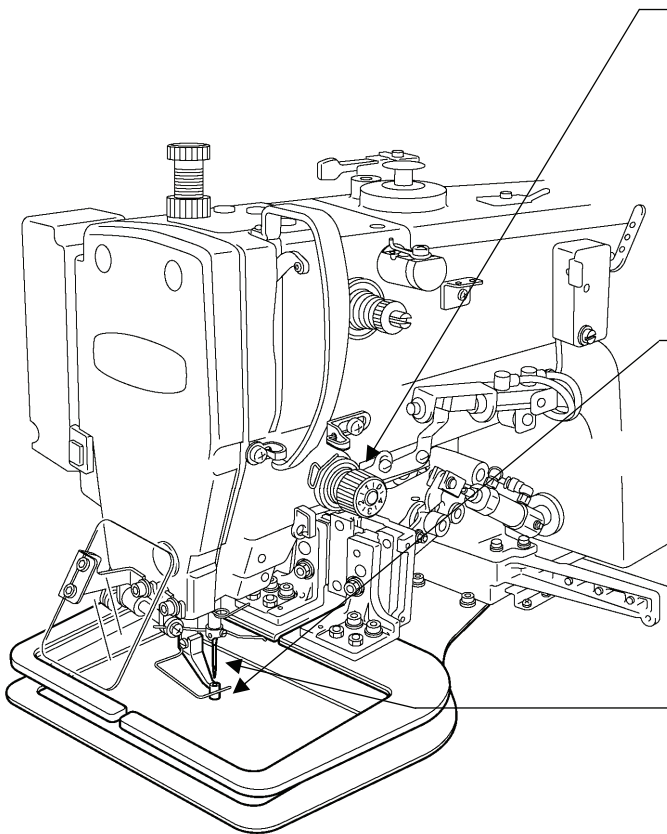

3689B

Easy threading in threading mode

➔ Page 24-25

When using threading mode for threading, the tension discs will open so that the thread can be threaded more easily.

Furthermore, threading mode is safe because the sewing machine will not start even when the start switch is depressed.

Intermittent presser foot height can be set easily using the LCD panel

➔ Page 37-38

The height of the intermittent presser foot can be set simply by entering a numeric value at the LCD panel, without the need for tools.

Furthermore, you can set the desired intermittent presser foot height separately for each sewing program.

Slow start pattern setting is easy









➔ Page 34

This is used to stop the thread from pulling out at the sewing start, and at times when skipped stitches might easily occur.

The starting-up speed at the sewing start can be adjusted easily.

3. INSTALLATION

⚠ CAUTION

-  Machine installation should only be carried out by a qualified technician.
-  Contact your Brother dealer or a qualified electrician for any electrical work that may need to be done.
-  The sewing machine head weighs approximately 88kg. The installation should be carried out by three or more people.
-  Do not connect the power cord until installation is complete.
If the foot switch is depressed by mistake, the sewing machine might start operating and injury could result.
-  Hold the machine head with both hands when tilting it back or returning it to its original position.
Furthermore, do not apply excessive force when tilting back the machine head. The sewing machine may become unbalanced and fall down, and serious injury or damage to the sewing machine may result.
-  All cords should be secured at least 25 mm away from any moving parts. Furthermore, do not excessively bend the cords or secure them too firmly staples, otherwise there is the danger that fire or electric shocks could occur.
-  Be sure to connect the ground. If the ground connection is not secure, you run a high risk of receiving a serious electric shock, and problems with correct operation may also occur.
-  Install the safety covers to the machine head and motor.

3-1. Table processing diagram

- The thickness of the table should be at least 40 mm, and it should be strong enough to bear the weight and vibration of the sewing machine.
- Check that the control box is at least 10 mm away from the leg. If the control box and the leg are too close together, it may result in incorrect sewing machine operation.

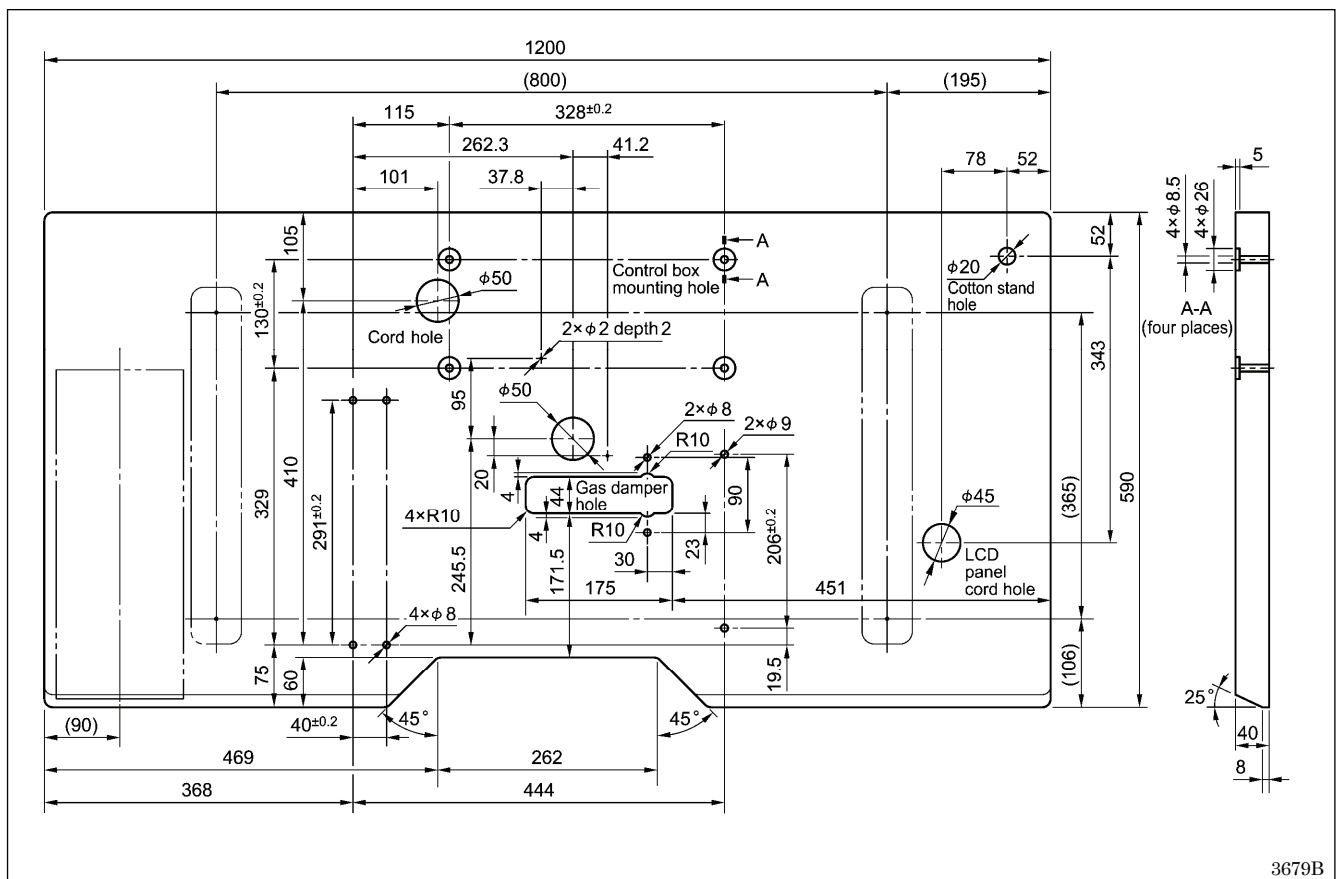

3. INSTALLATION

3-2. Installing the control box

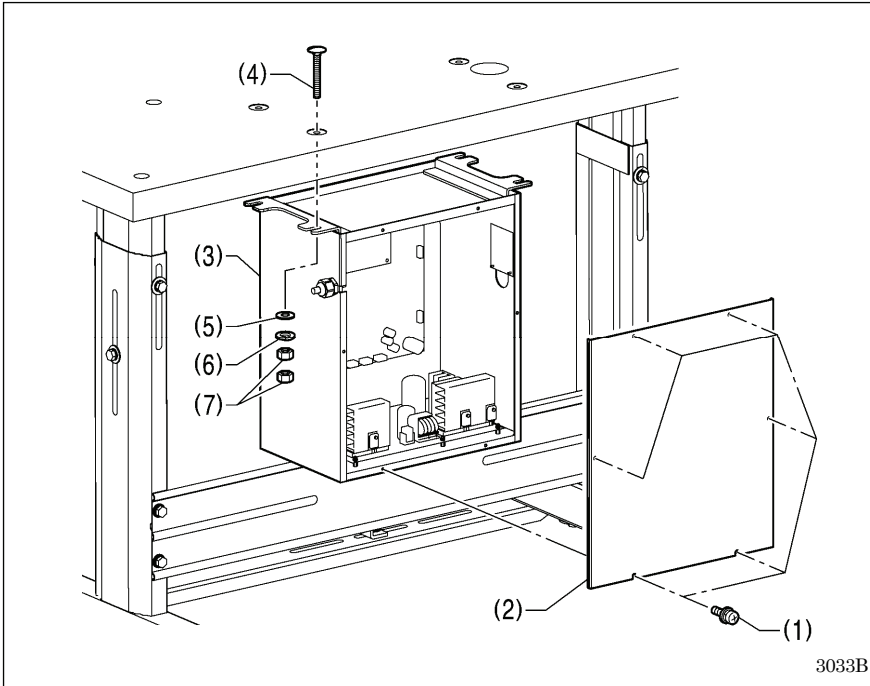

Remove the six screws (1), and then remove the control box cover (2).

- (3) Control box
- (4) Bolts [4 pcs.]
- (5) Plain washers [4 pcs.]
- (6) Spring washers [4 pcs.]
- (7) Nuts [8 pcs.]

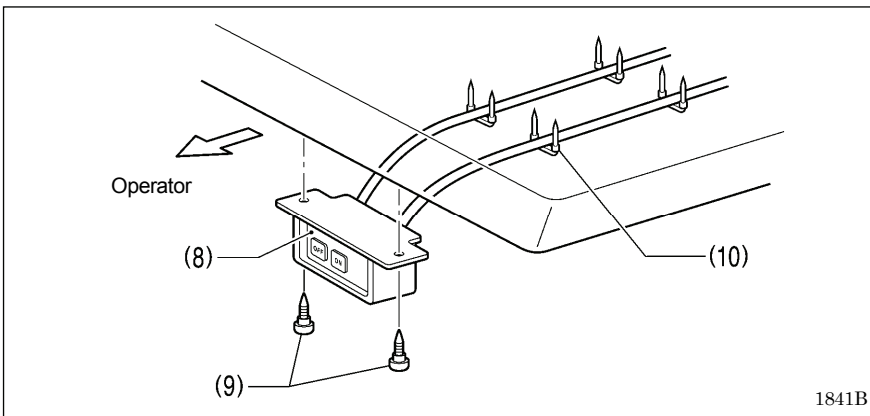

- (8) Power switch
- (9) Wood screws [2 pcs.]
- (10) Staples [4 pcs.]

3-3. Installing the oil pan

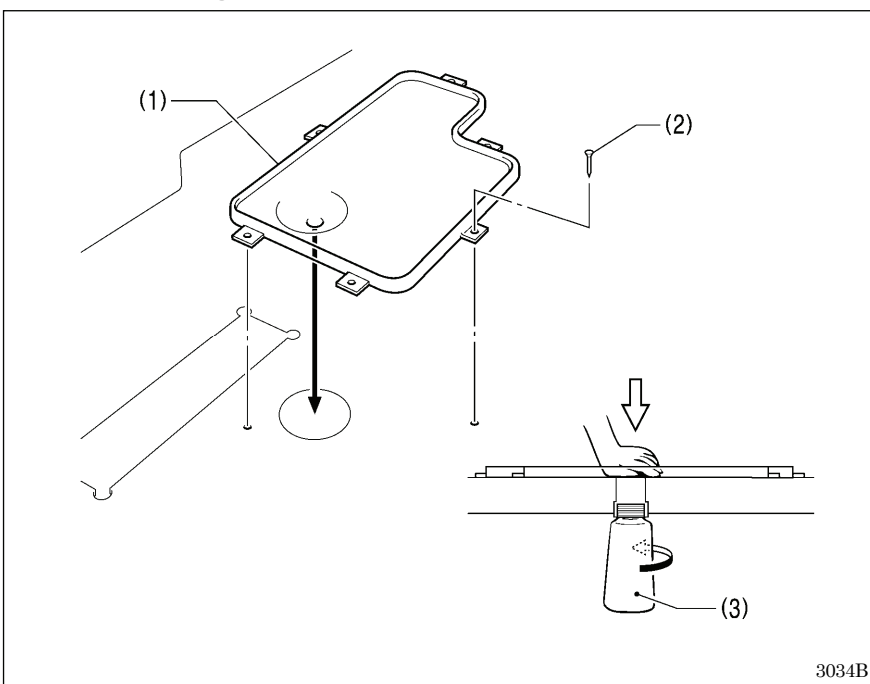

- (1) Oil pan
- (2) Nails [6 pcs.]
- (3) Waste oil tank

3-4. Installing the machine head

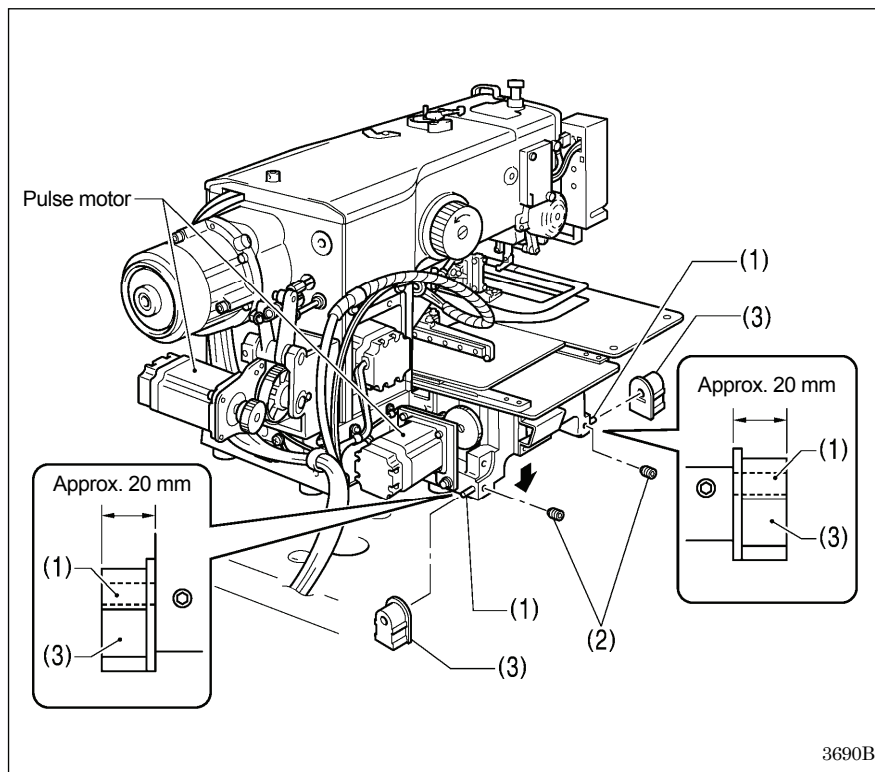

- (1) Pins [2 pcs.]
- (2) Set screws [2 pcs.]
- (3) Hinge rubber assemblies [2 pcs.]

Place the machine head gently on top of the oil pan.

NOTE:

- Be careful not to get the cords clamped between the machine head and the oil pan.
- When holding the machine head, do not hold it by the pulse motor. This may cause problems with operation of the pulse motor.

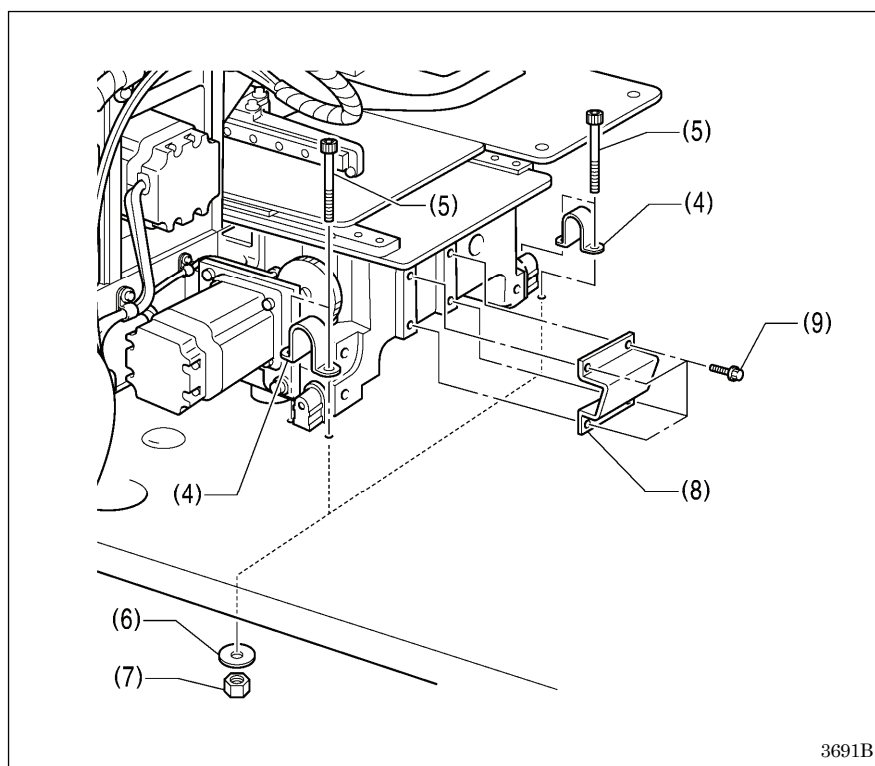

- (4) Hinge holders [2 pcs.]
- (5) Bolts [4 pcs.]
- (6) Plain washers [4 pcs.]
- (7) Nuts [4 pcs.]
- (8) Head rest
- (9) Bolts with washer [4 pcs.]

3. INSTALLATION

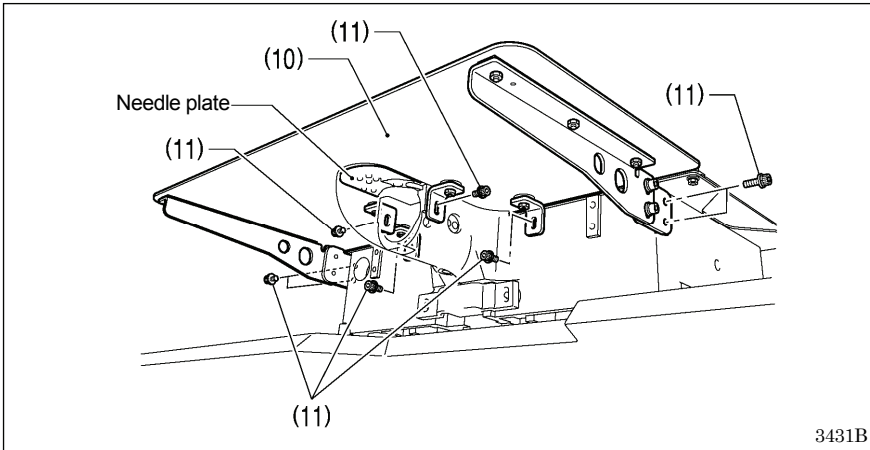

- (10) Auxiliary plate
- (11) Bolts with washer [8 pcs.]

Loosen the eight bolts with washer (11), and adjust so that the auxiliary plate (10) is 0 to 0.5 mm above the needle plate.

NOTE:

- Install the auxiliary plate (10) so that it is horizontal.
If the auxiliary plate (10) is lower than the needle plate, the feed plate may get caught on the needle plate.

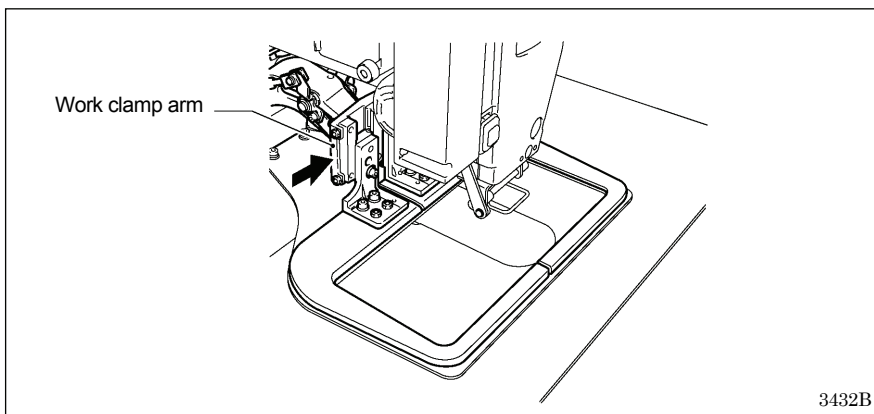

Move the work clamp arm all the way to the right when looking from the front of the sewing machine (the direction of the arrow in the illustration), and then gently tilt back the machine head.

NOTE:

- Three or more people should tilt back the machine head, and it should be tilted gently while being held with both hands.
- Be careful not to clamp any items such as screwdrivers under the cushion when tilting back the machine head.

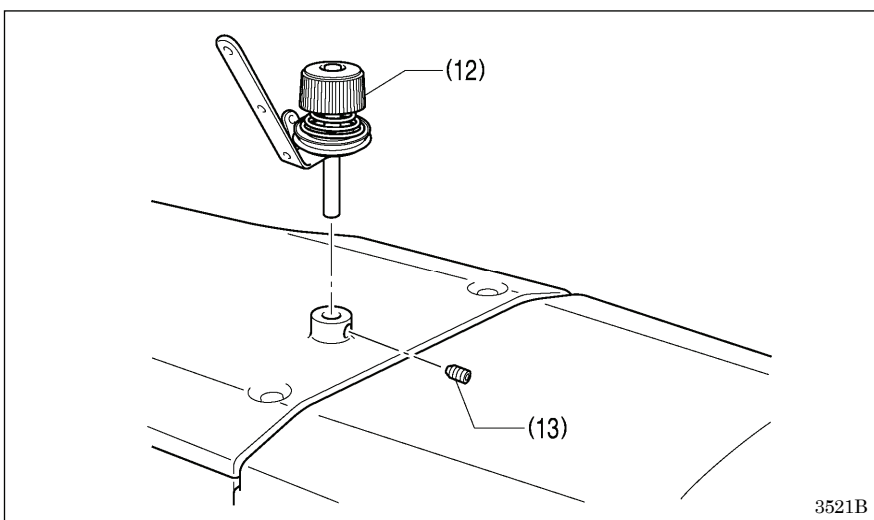

- (12) Bobbin winder tension assembly
- (13) Set screw [1 pc.]

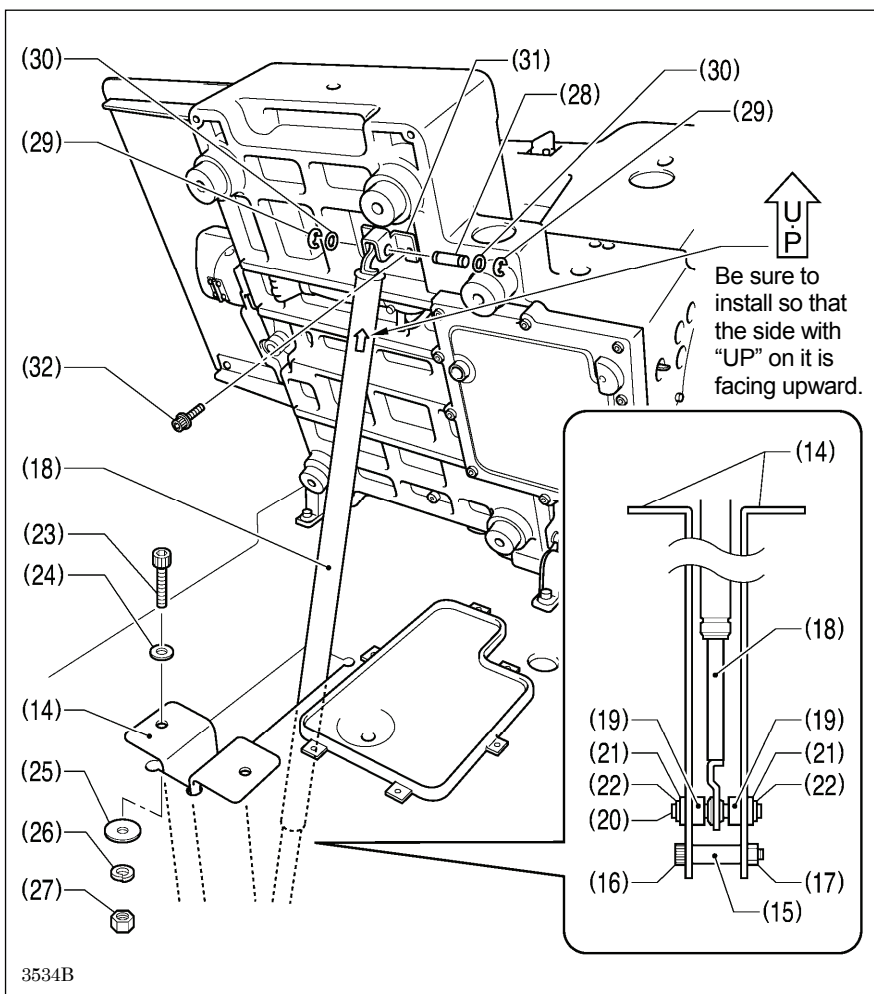

- (14) Gas spring holders [2 pcs.]
- (15) Spacer
- (16) Bolt
- (17) Nut
- (18) Gas spring
- (19) Shaft collars [2 pcs.]
- (20) Gas spring shaft D
- (21) Plain washers [2 pcs.]
- (22) Retaining rings E [2 pcs.]
- (23) Bolts [2 pcs.]
- (24) Plain washers (medium) [2 pcs.]
- (25) Plain washers (large) [2 pcs.]
- (26) Spring washers [2 pcs.]
- (27) Nuts [2 pcs.]
- (28) Gas spring shaft U
- (29) Retaining rings E [2 pcs.]
- (30) Plain washers (small) [2 pcs.]
- (31) Absorber setting plate
- (32) Bolts with washer [2 pcs.]

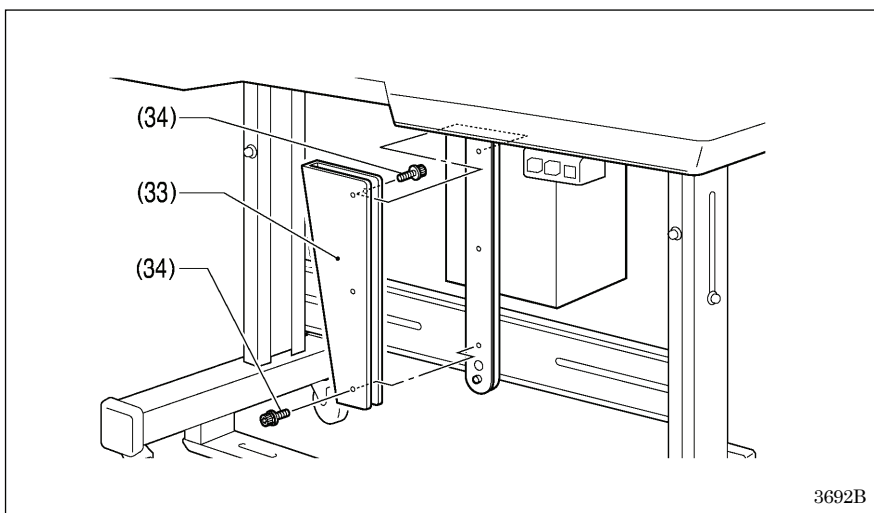

- (33) Gas spring support cover
- (34) Bolts with washer [6 pcs.]

3. INSTALLATION

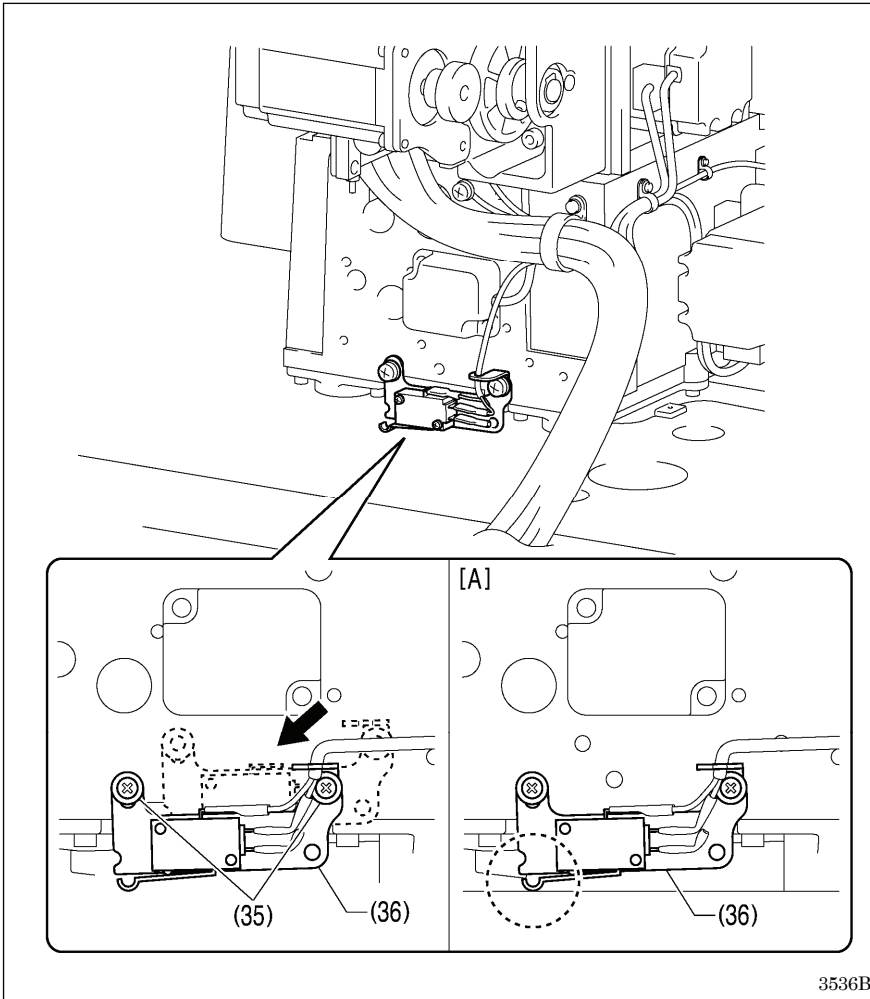

Gently return the machine head to its original position.

1. Remove the two screws (35), and then temporarily remove the machine head switch assembly (36).
2. Use the two screws (35) which were removed to install the machine head switch assembly (36) in the position shown in the illustration.
3. Check that the machine head switch as turned on as shown in figure [A].

* If the machine head switch is not turned on, adjust the installation position while referring to “3-17. Checking the machine head switch”.

3-5. Installing the LCD panel

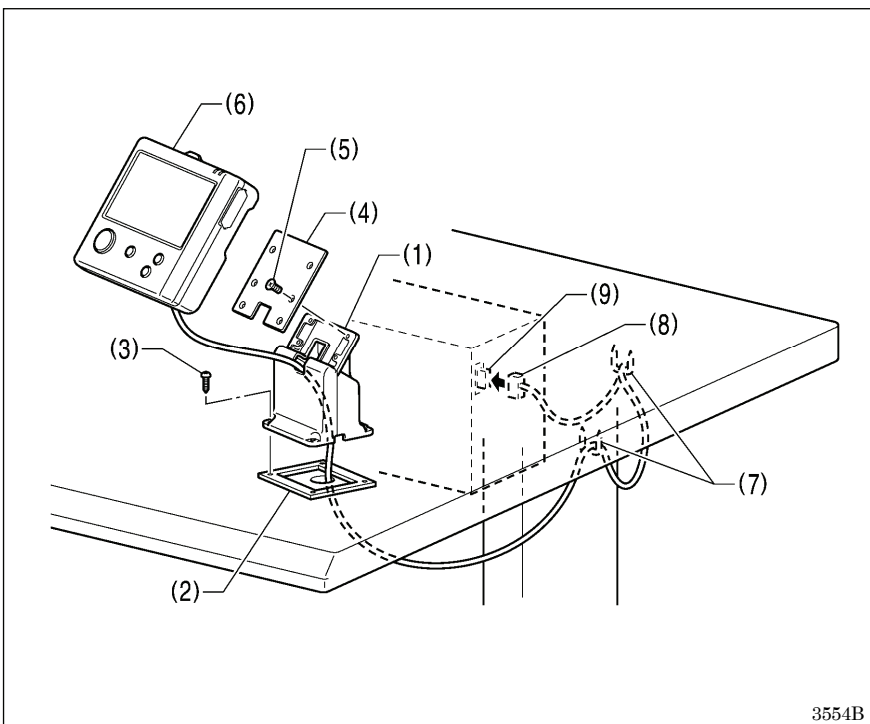

- (1) Cradle
- (2) Rubber cushion
- (3) Wood screws [4 pcs.]
- (4) Setting plate
- (5) Flat screws [4 pcs.]
- (6) LCD panel
- (7) Staples [2 pcs.]

• Pass the cord of the LCD panel (8) through the table hole, and then insert it into the (PANEL) connector (9) on the side of the control box.

• Tighten the four wood screws (3) so that the thickness of the rubber cushion (2) is 5 mm.

3-6. Installing the two-pedal foot switch

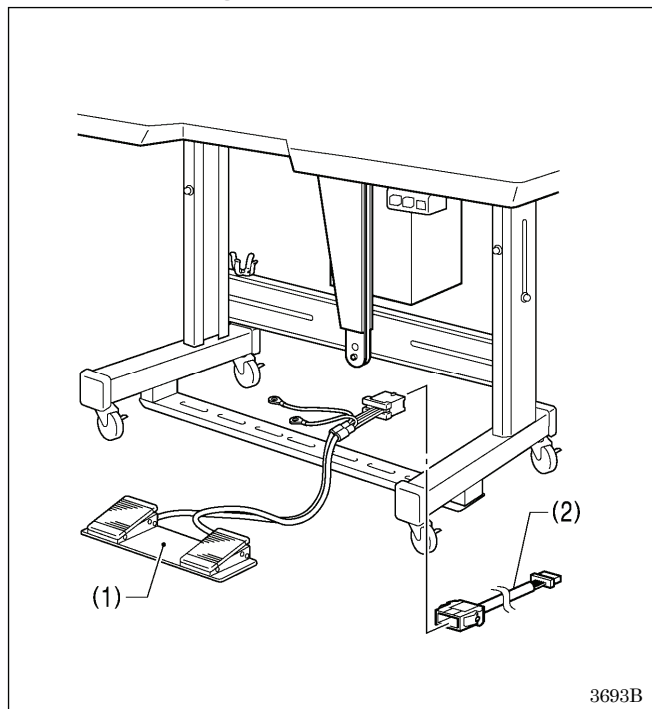

- (1) Two-pedal foot switch
- (2) Conversion harness

Connect the connector for the two-pedal foot switch (1) to the conversion harness (2). Insert the conversion harness (2) into the P15 (PEDAL) connector on the main P.C. board. (Refer to "3-7. Connecting the cords".)

* Be sure to make the ground connection. (Refer to "3-8. Connecting the ground wire".)

<Two-pedal foot switch operating method>

When the work clamp switch (left) is depressed, both work clamps are lowered, and when the start switch (right) is depressed, the sewing machine starts sewing.

* The work clamp lowering method can be changed using memory switch No. 002. (Refer to "2-2. List of memory switch settings" in the "LCD Panel/Operation Panel" Instruction Manual.) (*1)

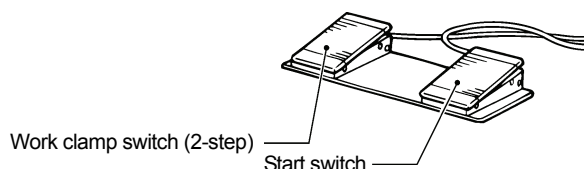

4923Q

3-7. Connecting the cords

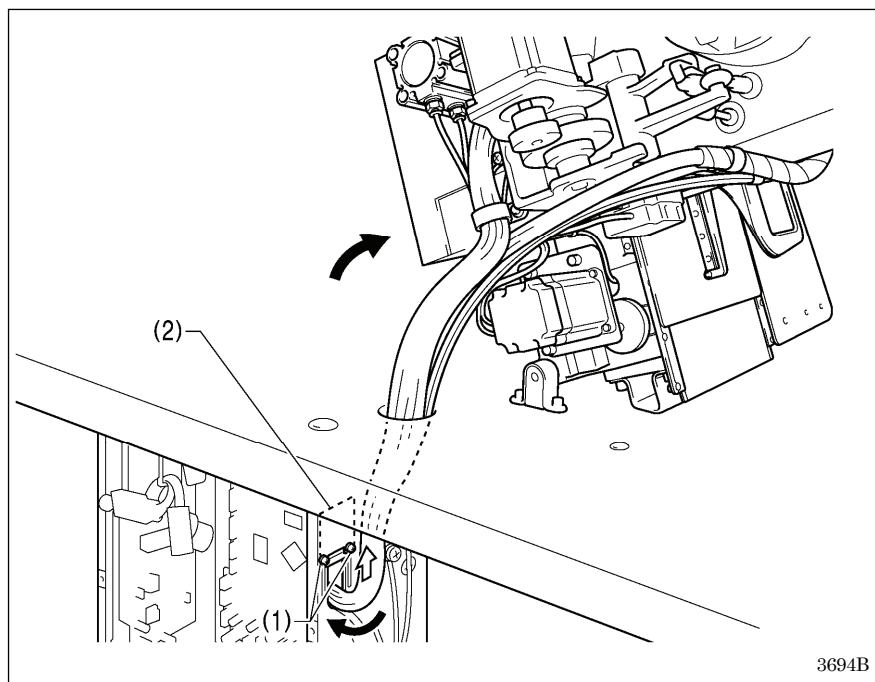

1. Gently tilt back the machine head.
2. Pass the cord bundle through the hole in the work table.
3. Loosen the two screws (1), and then open the cord presser plate (2) in the direction of the white arrow and pass the cord bundle through the opening.
4. Securely connect the connectors as indicated in the table below. (Refer to the next page.)

NOTE:

- Check that the connector is facing the correct way, and then insert it firmly until it locks into place.
- Secure the cables with cable ties and cord clamps, while being careful not to pull on the connector.

3694B

(*1) Please download the "LCD Panel/Operation Panel" Instruction Manual from our web site.

3. INSTALLATION

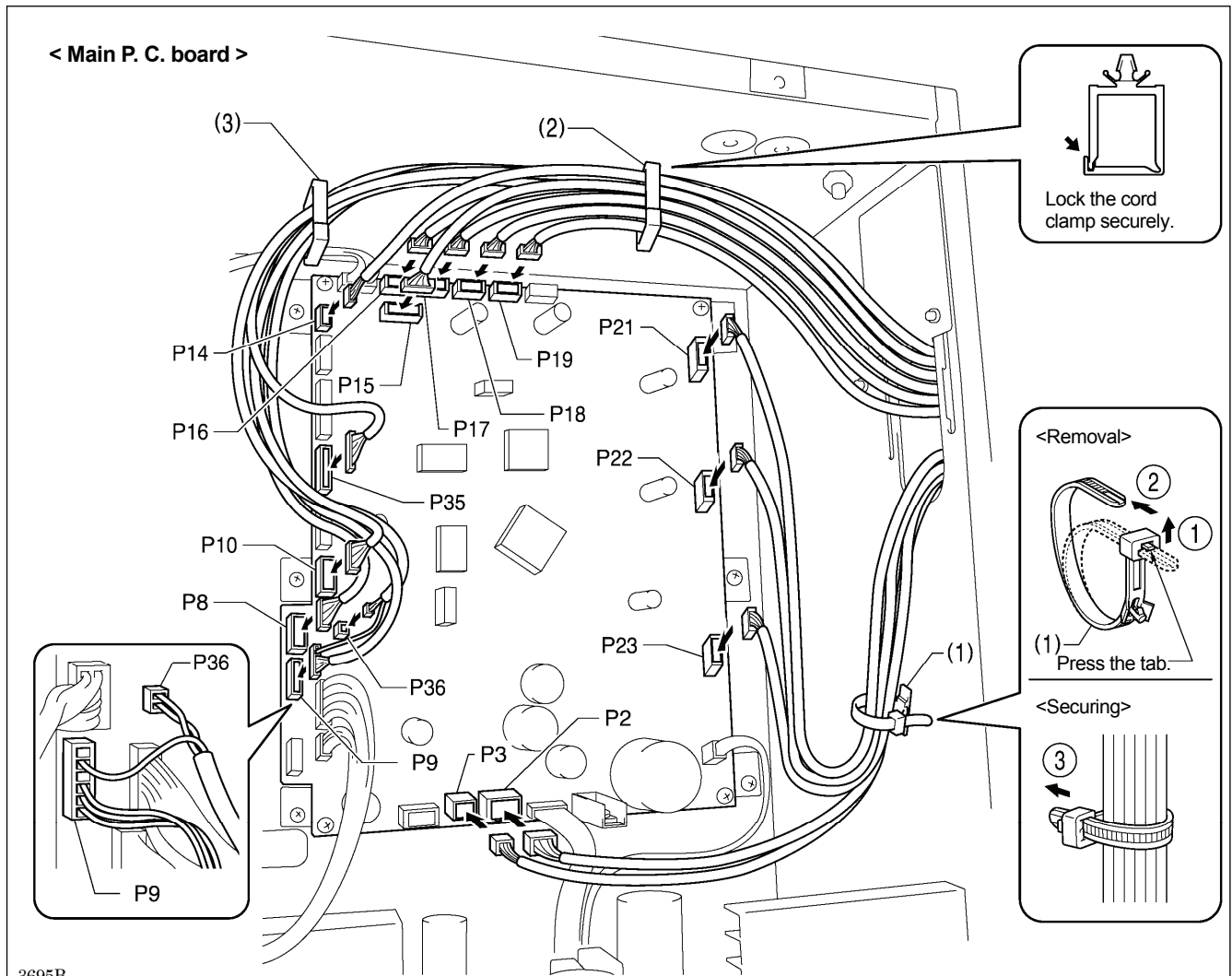

3695B

Connectors	Connection location on main P. C. board	Cord clamps / cable ties
X pulse motor encoder [5-pin] White	P17 (X-ENC)	(2)
Y pulse motor encoder [5-pin] Blue	P18 (Y-ENC)	(2)
Intermittent presser foot pulse motor encoder [5-pin] Black *1	P19 (P-ENC)	(2)
Machine head switch [3-pin]	P14 (HEAD-SW)	(2)
Conversion harness (two-pedal foot switch) [7-pin] White	P15 (PEDAL)	(2)
Machine head memory [6-pin]	P16 (HEAD-M)	(2)
Thread trimmer solenoid [6-pin]	P2 (SOL1)	(1)
Tension release solenoid [4-pin]	P3 (SOL2)	(1)
X pulse motor [4-pin] White	P21 (XPM)	(1)
Y pulse motor [4-pin] Blue	P22 (YPM)	(1)
Intermittent presser foot pulse motor [4-pin] Black *1	P23 (PPM)	(1)
Home position sensor [12-pin] White	P8 (SENSOR1)	(2) (3)
STOP switch [6-pin] White	P9 (HEAD)	(2) (3)
Valve harness [12-pin]	P35 (EX-OUT1)	(2) (3)
Upper thread breakage detector [2-pin] White	P36, P9(HEAD)	(2) (3)
Thread trimming cylinder sensor harness [16-pin]	P10 (EX-IN1)	(2) (3)

NOTE: Route the X, Y and lintermittent presser foot pulse motor harnesses so that they do not touch the power supply P.C. board at the bottom of the control box.

*1: Only applicable to -484 SF specifications.

< Motor P. C. board >

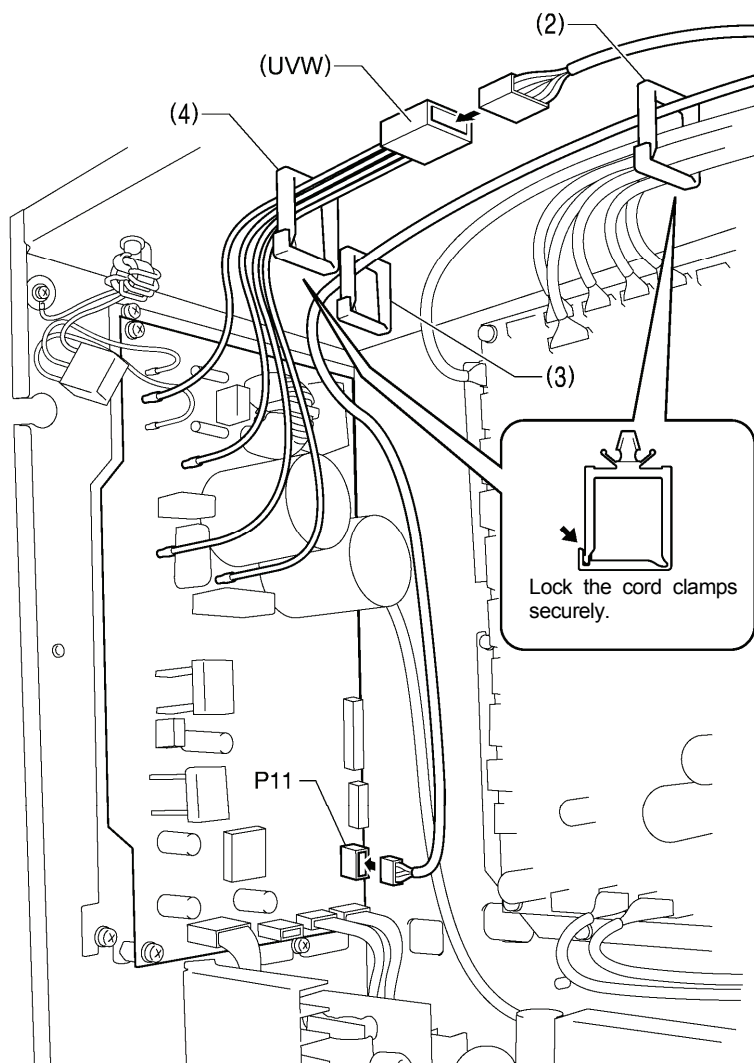

3537B

Connectors	Connection location on motor P. C. board	Cord clamps
Upper shaft motor [4-pin]	(UVW)	(4)
Synchronizer [10-pin]	P11 (SYNC)	(2) (3)

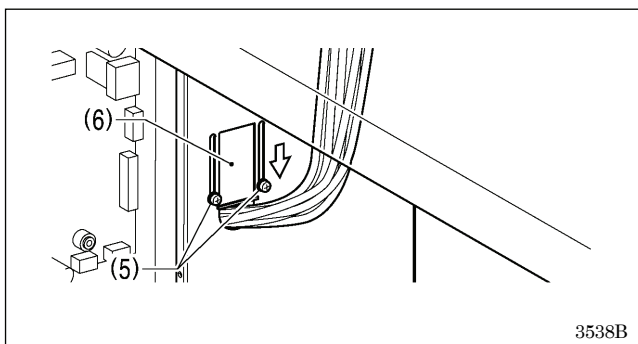

5. Close the cord presser plate (6) in the direction of the white arrow, and secure it by tightening the two screws (5).

NOTE:

Close the cord presser plate (6) securely so that no foreign objects, insects or small animals can get inside the control box.

6. Check that the cords do not get pulled, and then gently return the machine head to its original position.

3. INSTALLATION

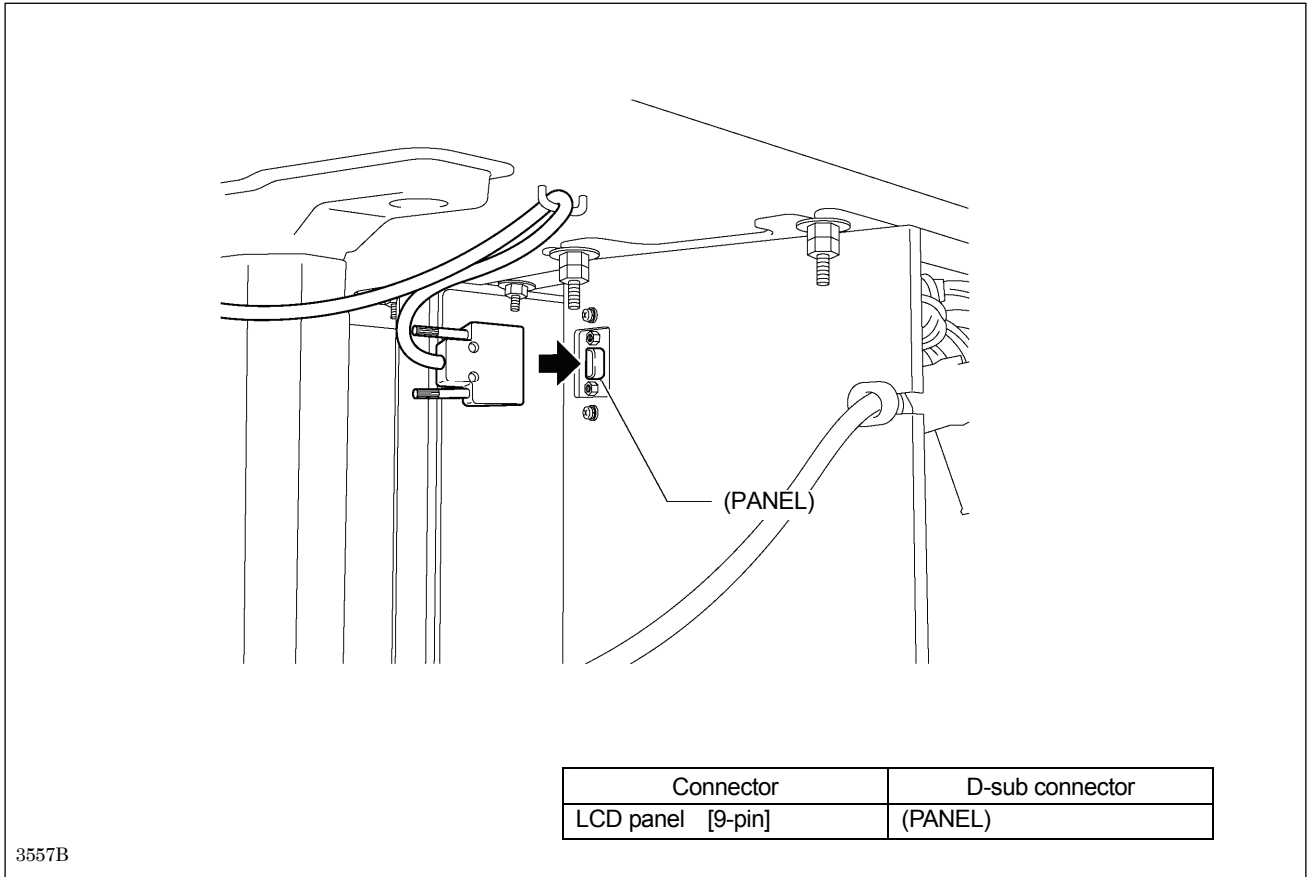

3-8. Connecting the ground wire

⚠ CAUTION



Be sure to connect the ground. If the ground connection is not secure, you run a high risk of receiving a serious electric shock, and problems with correct operation may also occur.

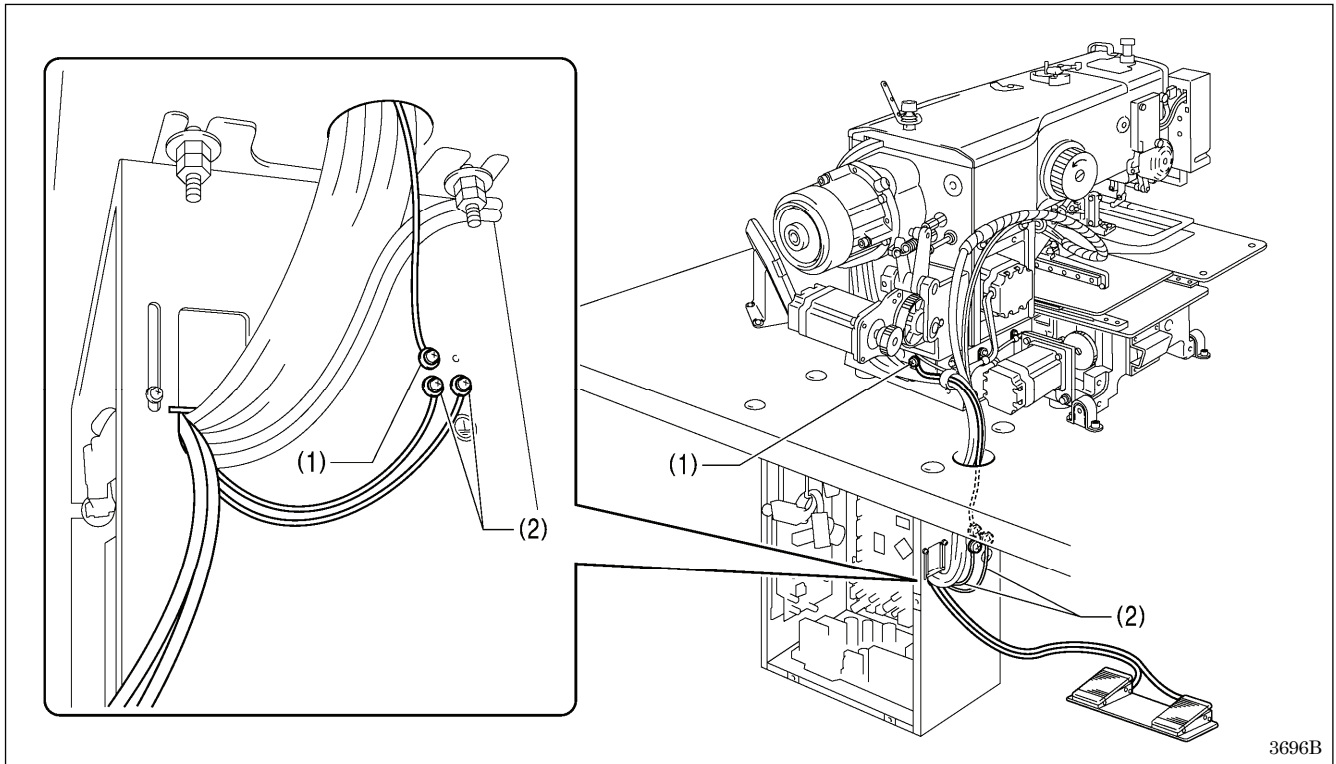

- (1) Ground wire from the machine head
 (2) Ground wires from two-pedal foot switch harnesses (2 wires)

- Tighten the control box cover with the six screws. Check that the cords are not clamped by the cover at this time.

NOTE: Make sure that the ground connections are secure in order to ensure safety.

3-9. Connecting the power cord

! CAUTION



Be sure to connect the ground. If the ground connection is not secure, you run a high risk of receiving a serious electric shock, and problems with correct operation may also occur.

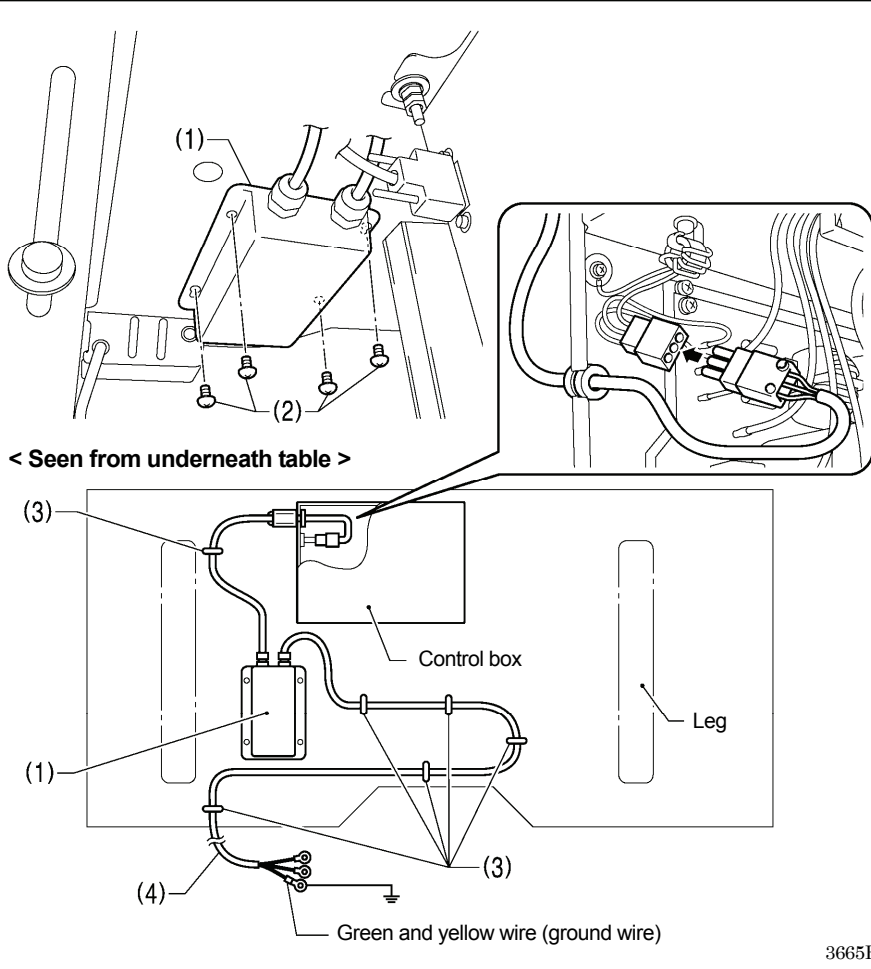

Connect cords that match the voltage specifications.

< EU specifications >

- (1) Filter box
- (2) Screws [4 pcs.]
- (3) Staples [6 pcs.]
- (4) Power cord

1. Attach an appropriate switch and cable to the power cord (4). (The green and yellow wire is the ground wire.)
2. Insert the power plug into a properly-grounded electrical outlet.

NOTE:

- Take care when tapping in the staples (3) to make sure that they do not pierce the cords.
- Do not use extension cords, otherwise machine operation problems may result.

3665B

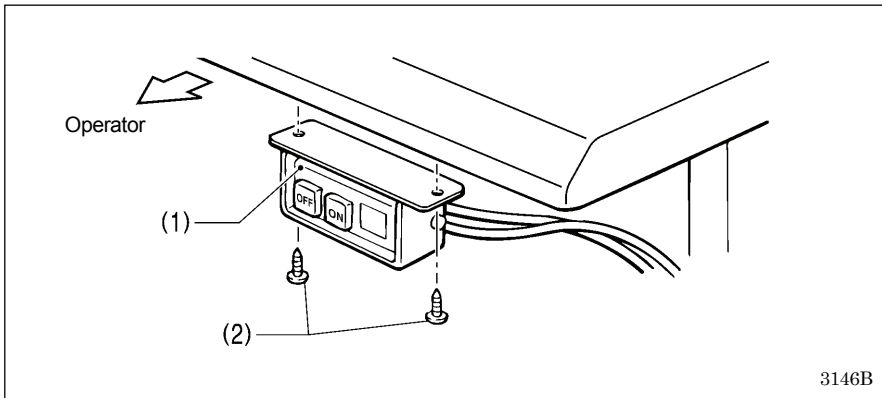

<200 V system >

- (1) Power switch
- (2) Wood screws [2 pcs.]

3146B

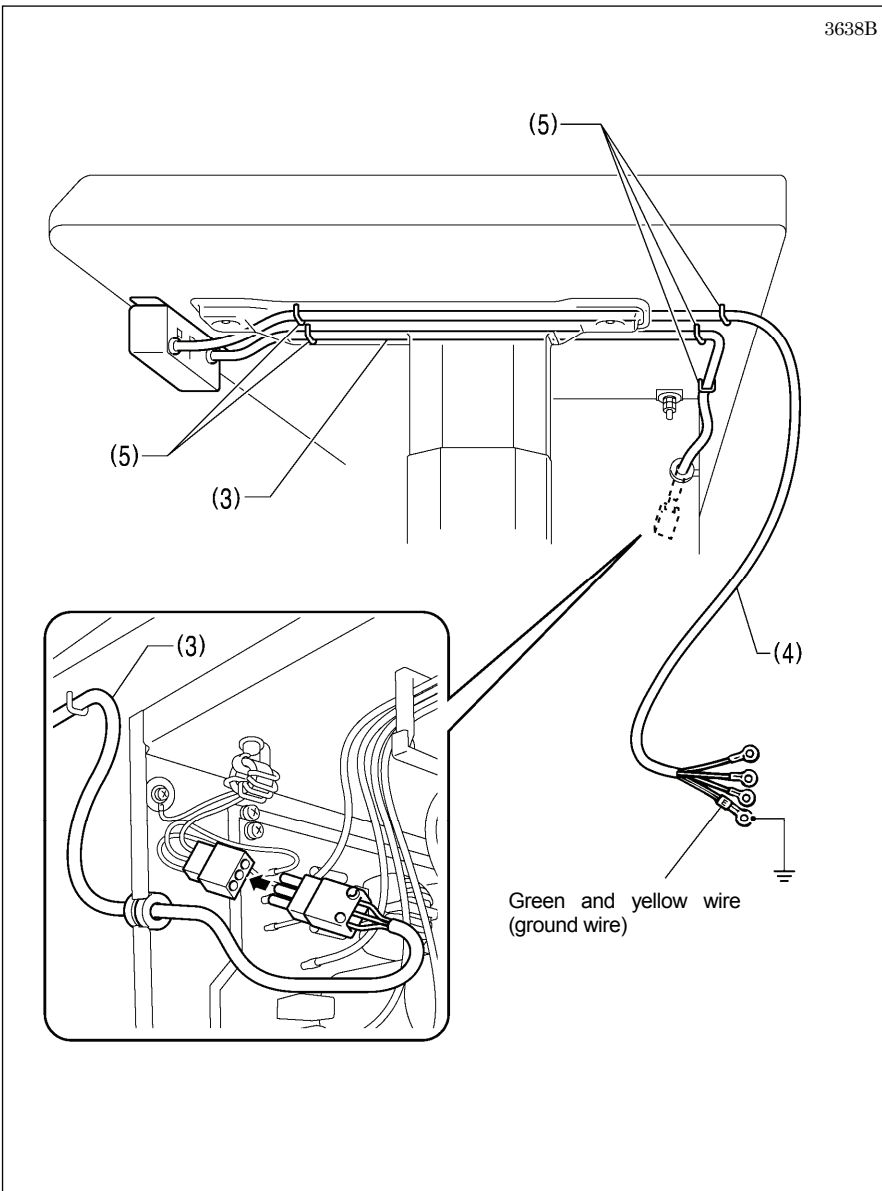

3638B

- (3) 3-pin power supply connector
- (4) Power cord
- (5) Staples [5 pcs.]

1. Attach an appropriate plug to the power cord (4). (The green and yellow wire is the ground wire.)
2. Insert the power plug into a properly-grounded electrical outlet.

NOTE:

- Take care when tapping in the staples (5) to make sure that they do not pierce the cords.
 - Do not use extension cords, otherwise machine operation problems may result.
3. Use the six screws to tighten the cover of the control box. Check that none of the cords are being clamped by the cover at this time.

3. INSTALLATION

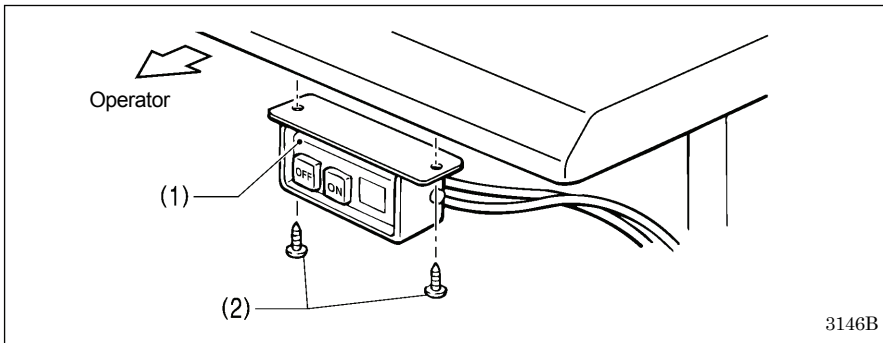

<100 V / 400 V system >

- (1) Power switch
- (2) Wood screws [2 pcs.]

3146B

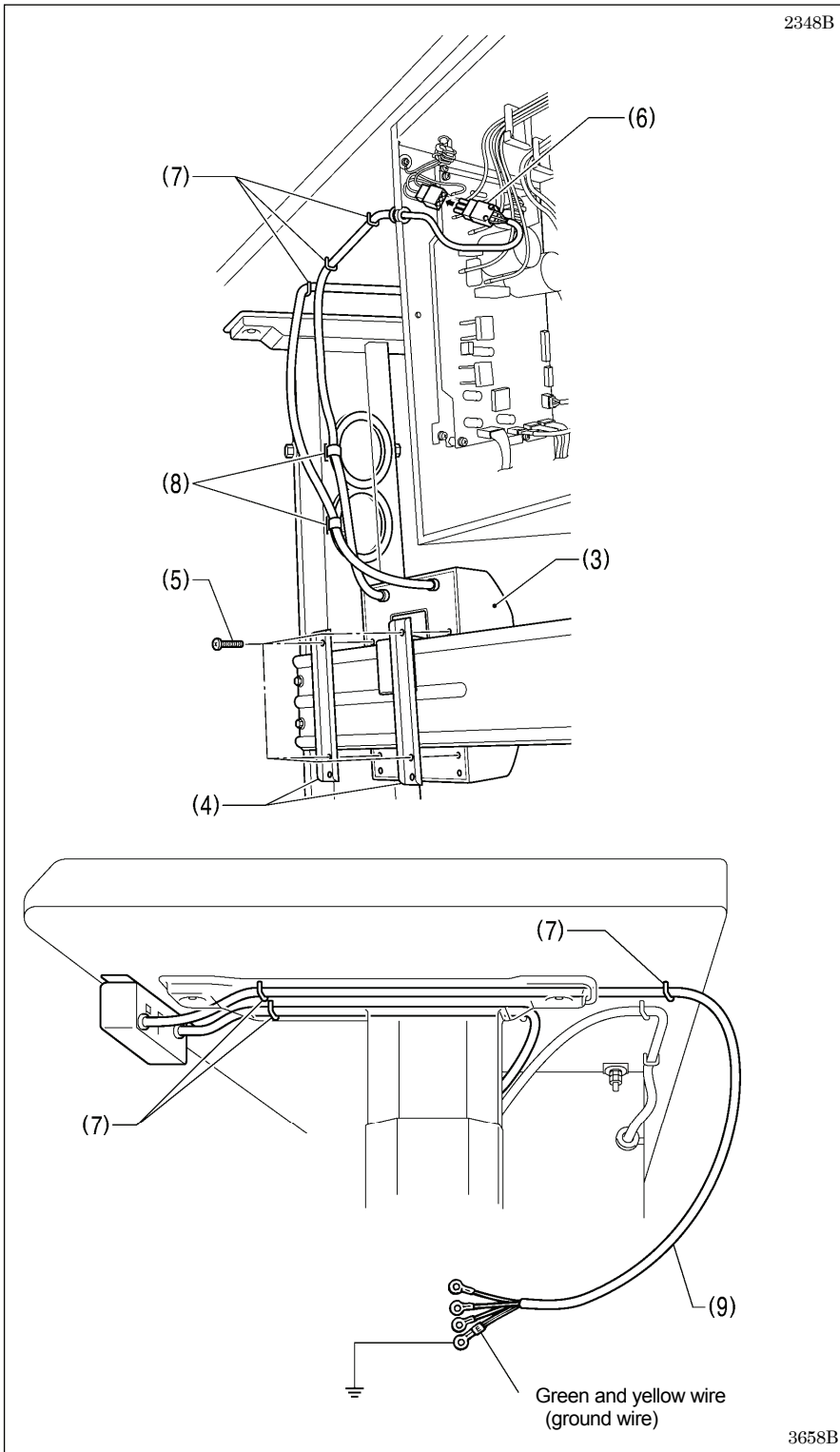

2348B

- (3) Transformer box
- (4) Transformer box plates [2 pcs.]
- (5) Screws [with washer] [4 pcs.]
- (6) 3-pin power supply connector
- (7) Staples [6 pcs.]
- (8) Cord clamps [2 pcs.]
- (9) Power cord

1. Attach an appropriate plug to the power cord (9). (The green and yellow wire is the ground wire.)
2. Insert the power plug into a properly-grounded electrical outlet.

* The inside of the control box uses single-phase power.

NOTE:

- If the ground connection is not secure, electric shocks, operating errors or damage to electronic components such as P.C. boards may occur.
- Take care when tapping in the staples (7) to make sure that they do not pierce the cords.
- Do not use extension cords, otherwise machine operation problems may result.

3. Use the six screws to tighten the cover of the control box. Check that none of the cords are being clamped by the cover at this time.

3658B

3-10. Installing the cotton stand

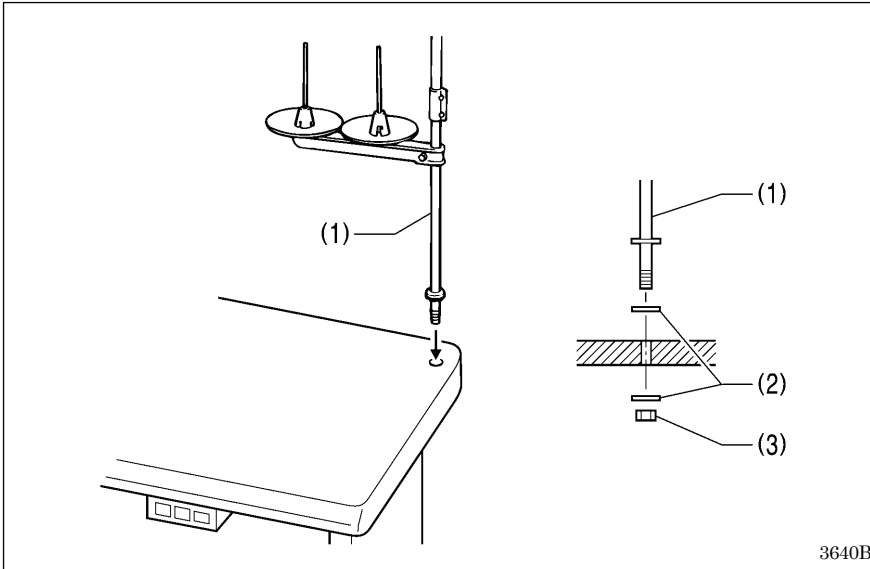

(1) Cotton stand

NOTE:

Securely tighten the nut (3) so that the two washers (2) are securely clamped so that the cotton stand (1) does not move.

3-11. Installing the pneumatic unit

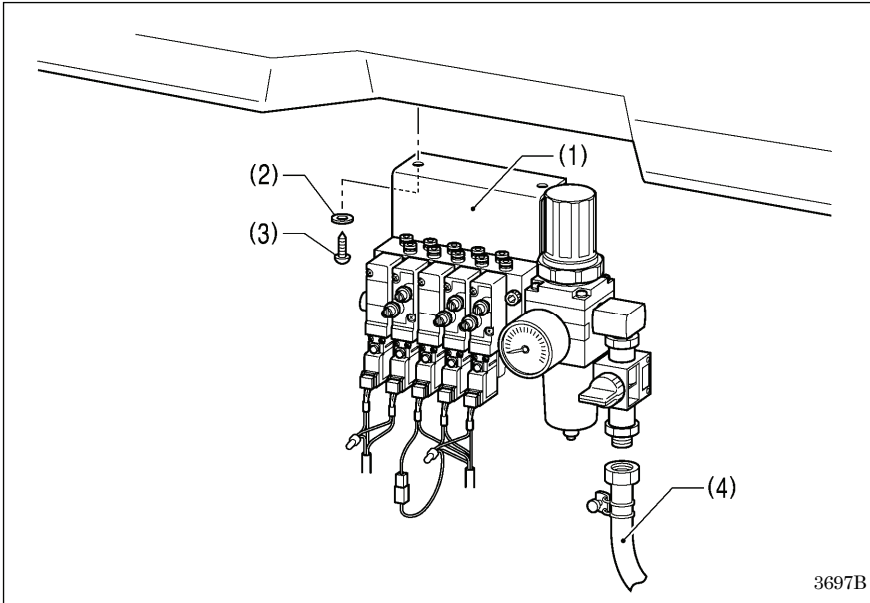

1. Install the pneumatic unit underneath the work table.

- (1) Solenoid valve assembly
- (2) Washers [2 pcs.]
- (3) Wood screws [2 pcs.]
- (4) Rubber hose

NOTE:

Make sure that the pneumatic unit does not touch the control box or the work table leg.

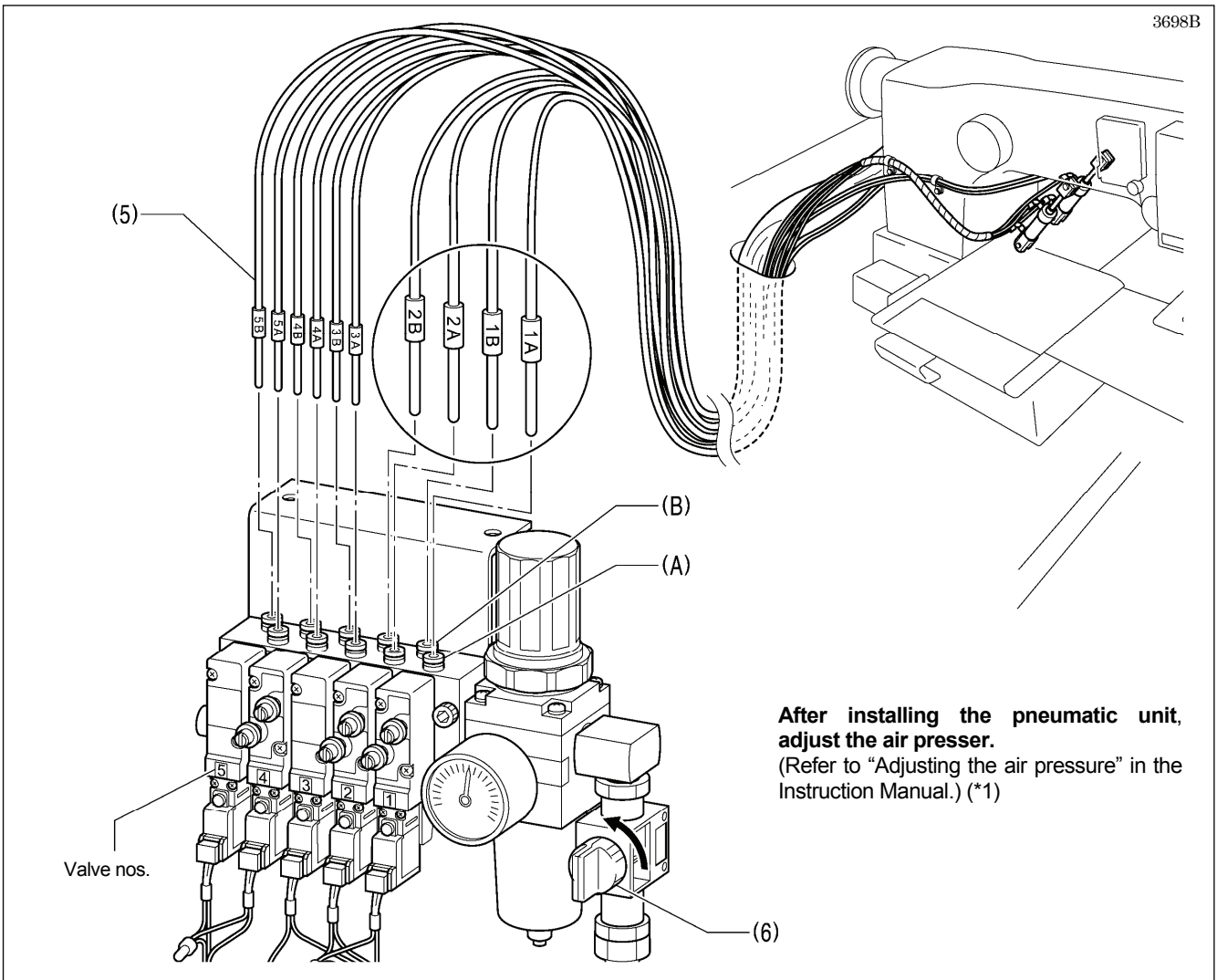

After installing the pneumatic unit, adjust the air presser.

(Refer to "Adjusting the air pressure" in the Instruction Manual.) (*1)

2. Connect each of the air tubes (5) to the valves so that all of the numbers match respectively.

The air tubes (5) marked with an A connect to the front valve connections (A), and those marked with B connect to the rear connections (B).

3. Open the air cock (6).

(*1) Please download the Instruction Manual for the sewing machine from our web site.

3-12. Adjusting the speed controller

<Adjusting the lifting and lowering speed for the work clamps>

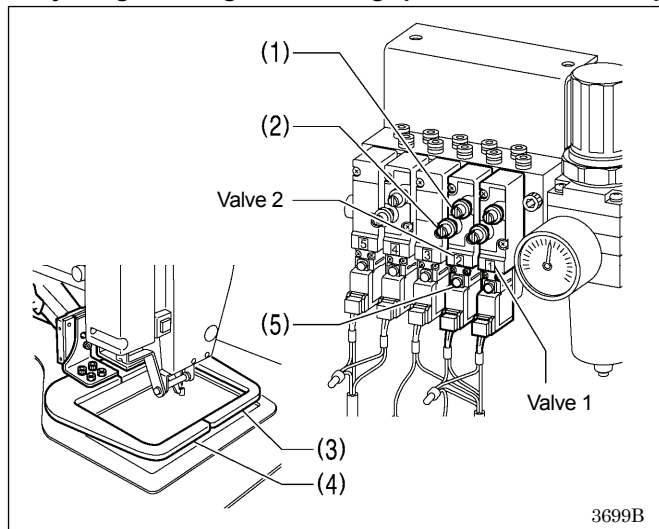

You can adjust the lifting and lowering speed for the work clamps using the knobs (1) and (2) on valves 1 and 2.

Valve 1 adjusts the right work clamp (3), and valve 2 adjusts the left work clamp (4).

The knobs (1) and (2) should be adjusted so that the left and right work clamps operate at the same speed.

- When the upper knob (1) is tightened, the lifting speed becomes slower. When it is loosened, the lifting speed becomes faster.
- When the lower knob (2) is tightened, the lowering speed becomes slower. When it is loosened, the lowering speed becomes faster.

You can operate the work clamps when the power is turned off by pressing the manual buttons (5).

<Adjusting the thread take-up lever operating speed>

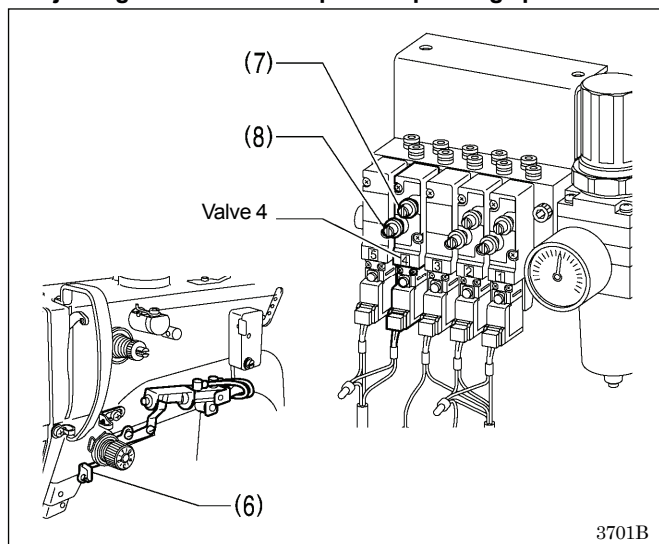

Valve 4 is used for adjusting the operating speed of the thread take-up lever (6).

To use, fully tighten both the upper and lower knobs (7) and (8), and then loosen them both by 6 turns.

NOTE:

If the knobs (7) and (8) are tightened more than the settings mentioned above, the upper thread trailing length may not be maintained correctly.

3-13. Installing the eye guard

⚠ CAUTION



Attach all safety devices before using the sewing machine.
If the machine is used without these devices attached, injury may result.

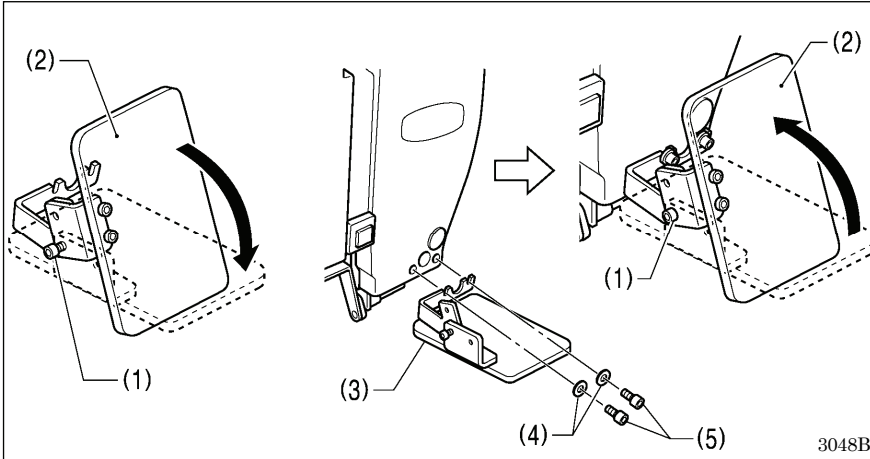

- (1) Bolt (loosen)
- (2) Eye guard (tilt forward)
- (3) Eye guard assembly
- (4) Plain washers [2 pcs.]
- (5) Bolts [2 pcs.]

After installing the eye guard assembly (3), return the eye guard (2) to its original angle, and then tighten the bolt (1) to secure it in place.

3-14. Installing the side cover and rear cover

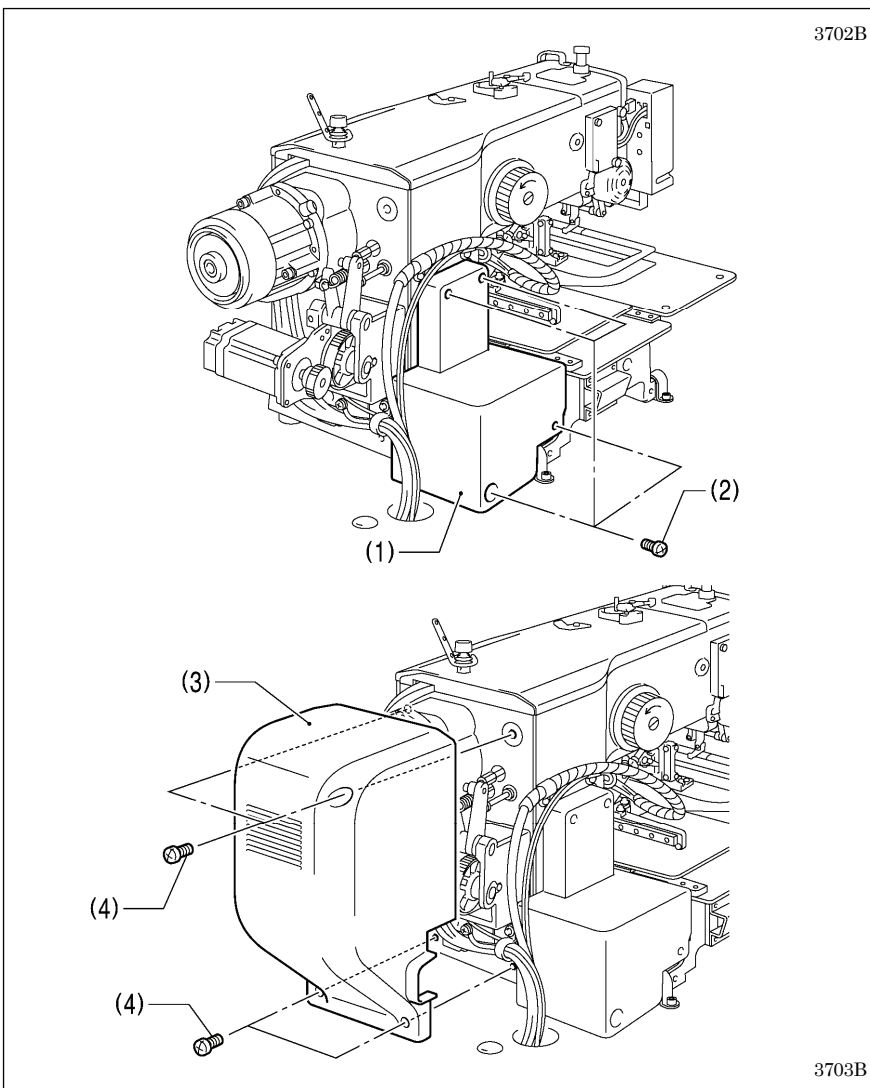

- (1) Side cover
- (2) Screws [4 pcs.]
- (3) Rear cover
- (4) Screws [4 pcs.]

NOTE:

Be careful not to clamp the cords when installing the side cover and the rear cover.

3-15. Lubrication

 **CAUTION**

Do not connect the power cord until lubrication is complete.
If the foot switch is depressed by mistake, the sewing machine might start operating and injury could result.



Be sure to wear protective goggles and gloves when handling the lubricating oil and grease, so that they do not get into your eyes or onto your skin. If the oil and grease get into your eyes or onto your skin, inflammation can result. Furthermore, do not drink or eat the lubricating oil or grease. They may cause diarrhea or vomiting. Keep the oil out of the reach of children.

The sewing machine should always be lubricated and the oil supply replenished before it is used for the first time, and also after long periods of non-use.

Use only the lubricating oil <JX Nippon Oil & Energy Corporation Sewing Lube N10; VG10> specified by Brother.

* If this type of lubricating oil is difficult to obtain, the recommended oil to use is <Exxon Mobil EssoTex SM10; VG10>.

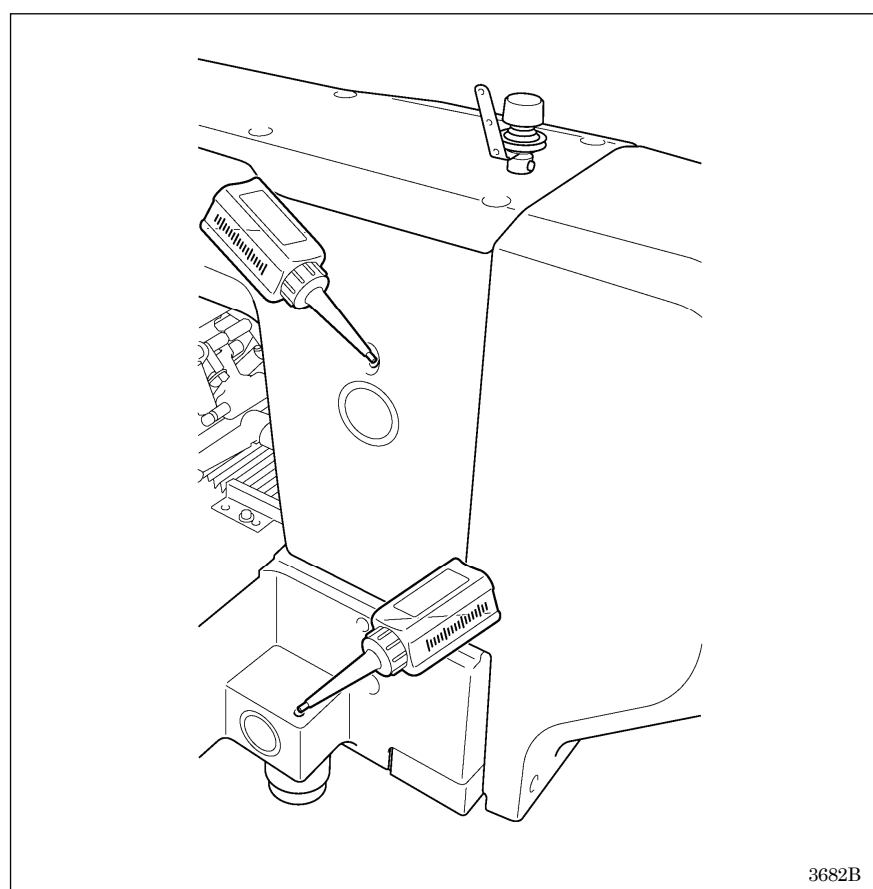

1. Fill the arm-side oil tank with oil.
2. Fill the bed-side oil tank with oil.

NOTE:

Be sure to fill the machine with oil when the oil level is down to about one-third full in the oil sight glass. If the oil drops below the one-third level, there is the danger that the machine may seize during operation.

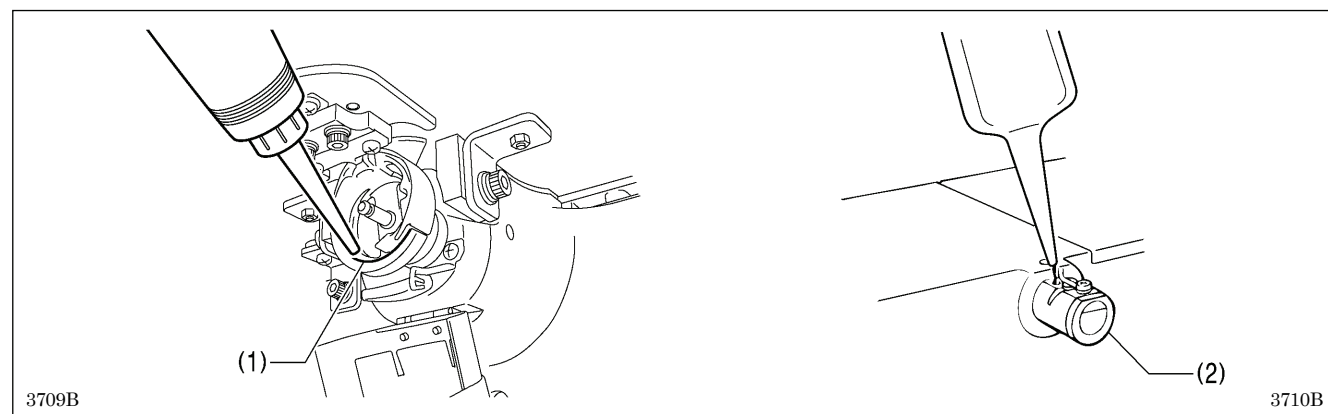

3. Remove the bobbin case and add 2-3 drops of oil to the sliding parts (1) of the outer rotary hook and inner hook.
4. If using the needle cooler (2), fill it with optional silicon oil (100 mm²/s). (Refer to "4-2. Threading the upper thread".)

3-16. Installing the machine head fixing bolt

When transporting the sewing machine, secure the machine head to the table with the machine head fixing bolts.

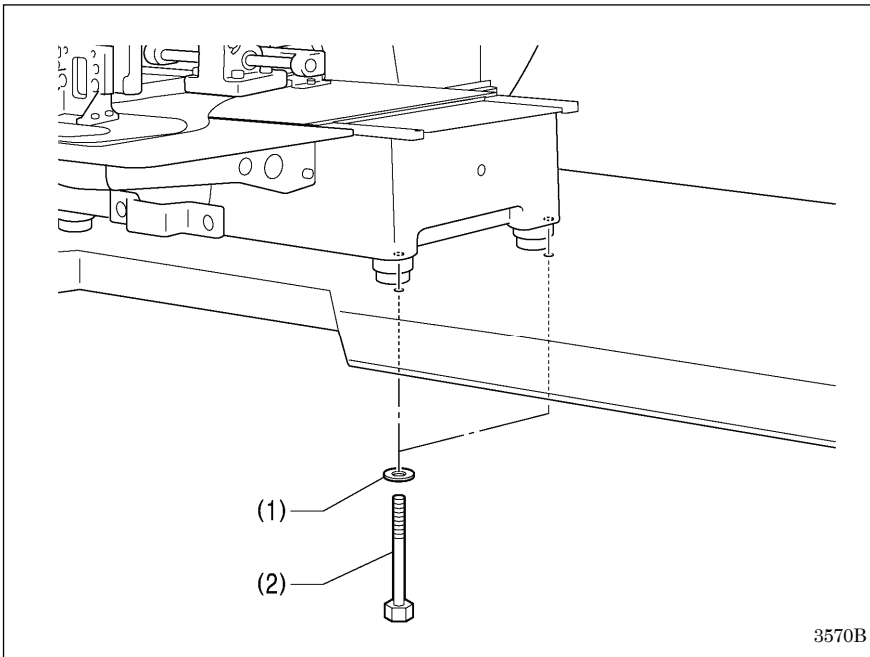

- (1) Plain washers [2 pcs.]
- (2) Machine head fixing bolts [2 pcs.]

NOTE:

When operating the sewing machine, remove the machine head fixing bolts.

3-17. Checking the machine head switch

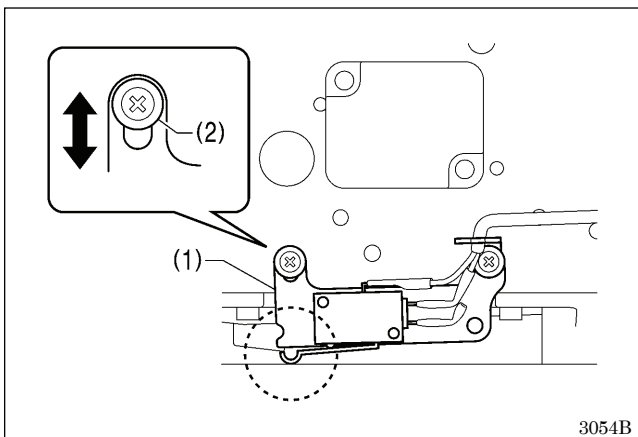

- 1. Turn on the power.
- 2. Check that no error numbers appear.

<If error [E050], [E051] or [E055] is displayed>

If the machine head switch (1) is not turned on, error [E050], [E051] or [E055] will occur.

Use the screw (2) to adjust the installation position of the machine head switch as shown in the illustration.

4. PREPARATION BEFORE SEWING

4-1. Installing the needle

CAUTION



Turn off the power switch before installing the needle.

If the foot switch is depressed by mistake, the sewing machine might start operating and injury could result.

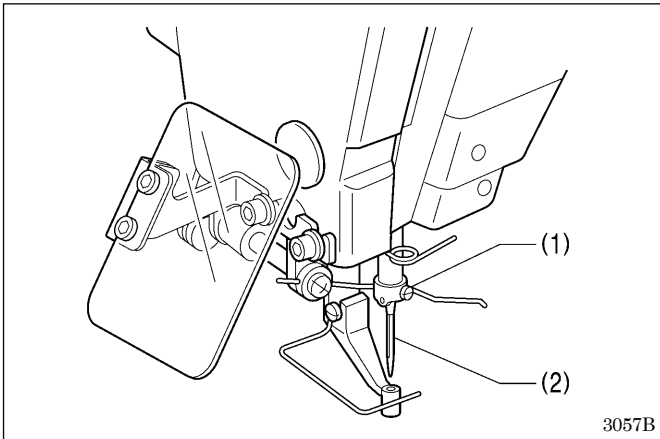

1. Loosen the set screw (1).
2. Insert the needle (2) in a straight line as far as it will go, making sure that the long groove on the needle is at the front, and then securely tighten the set screw (1).

4-2. Threading the upper thread

Thread the upper thread correctly as shown in the illustration below.

- * When using threading mode for threading, the tension discs (1) will open so that the thread can be threaded more easily. Refer to <Threading mode> (P.25)

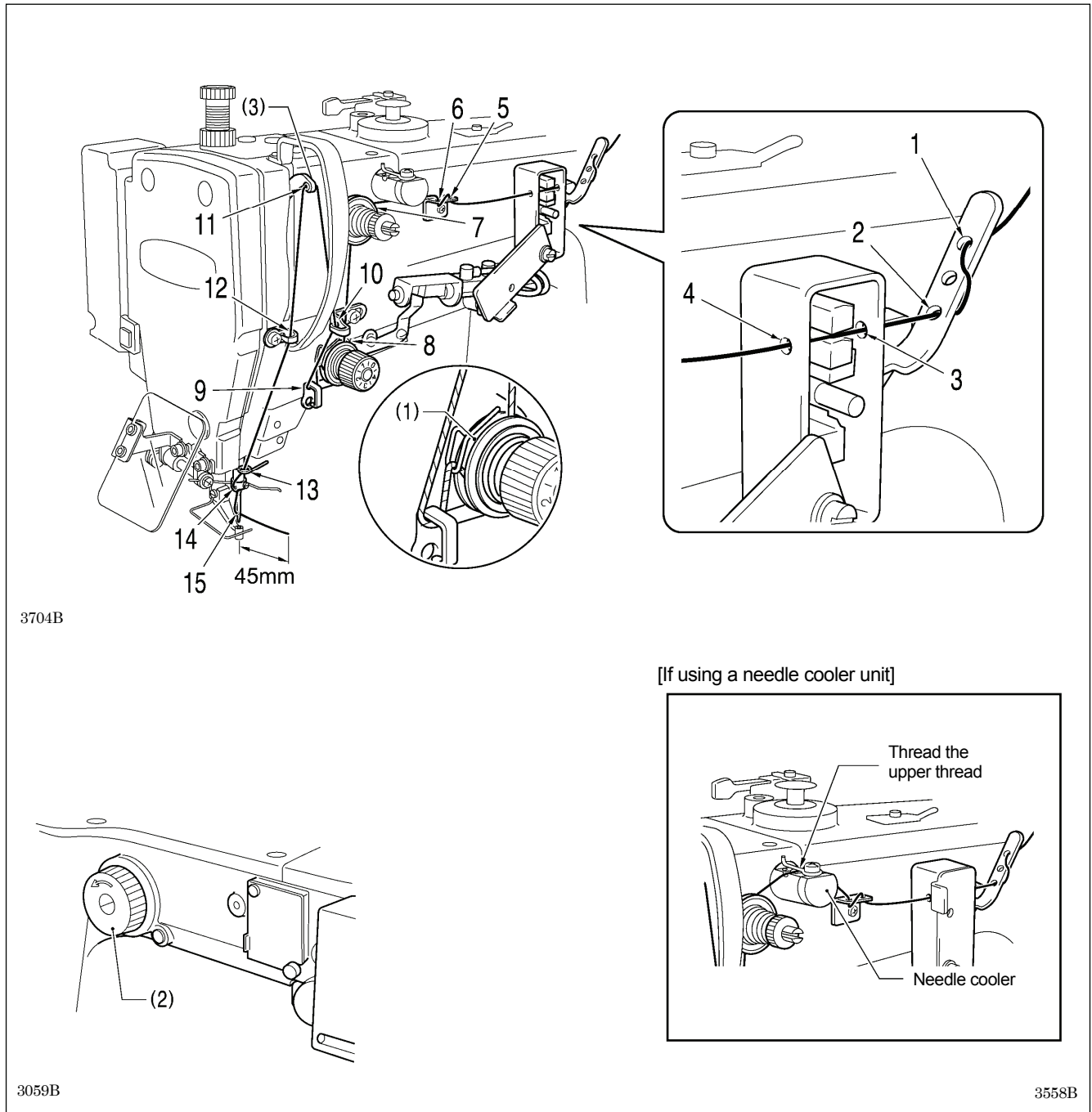





- Turn the machine pulley (2) and raise the thread take-up (3) to its highest position before threading the upper thread. (This will make threading easier and it will prevent the thread from coming out at the sewing start.)
- When threading the thread through the needle, allow a distance of approximately 45 mm between the needle hole and the end of the thread. If it is too long, the thread may become tangled, and if it is too short, the thread may pull out at the sewing start.
- If you would like to adjust the sensitivity of the thread breakage sensor, refer to "Adjusting the sensitivity of the thread breakage sensor" in the Instruction Manual. (*1)

(*1) Please download the Instruction Manual for the sewing machine from our web site.

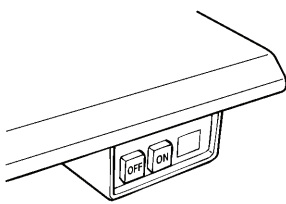
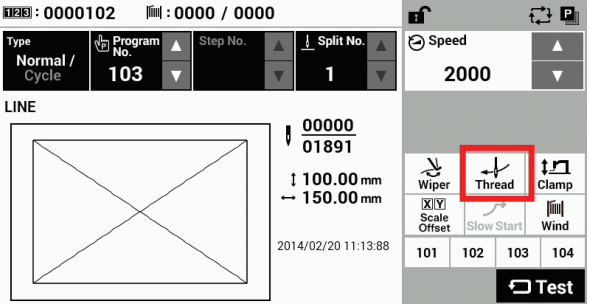
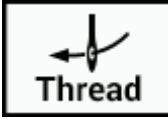
<Threading mode>

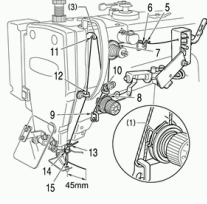
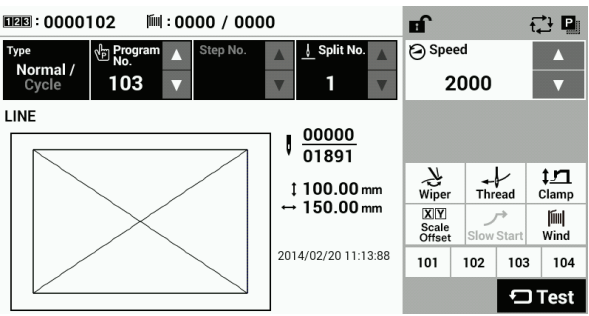
Threading mode is safe because the sewing machine will not start even when the start switch is depressed.

1		<p>Turn on the power.</p>
2	<div style="display: flex; justify-content: space-between;"> <div style="width: 45%;">  </div> <div style="width: 50%; padding-left: 10px;"> <p>Touch the Thread key on the screen.</p> <div style="text-align: center; margin-bottom: 10px;">  </div> <ul style="list-style-type: none"> The work clamps (and the intermittent presser foot *1) will drop. The tension discs (1) will open. </div> </div> <div style="text-align: center; margin: 10px 0;">  </div> <div style="border: 1px solid black; padding: 5px;"> <p>Threading</p>  <ol style="list-style-type: none"> 1. Turn the machine pulley (2) and raise the thread take-up (3) to its highest position before threading the upper thread. (This will make threading easier and it will prevent the thread from coming out at the sewing start.) 2. When threading the thread through the needle, allow a distance of approximately 45 mm between the needle hole and the end of the thread. 3. Touch the OK key to return to the previous screen. <div style="text-align: right; margin-top: 5px;"> OK </div> </div>	
3	<p>Threading the thread.</p>	
4	<p>Ending threading mode</p> <p>The display will return to the previous screen.</p> 	<p>Touch the OK key on the screen.</p> <div style="text-align: center; margin-bottom: 10px;">  </div> <ul style="list-style-type: none"> The work clamps (and the intermittent presser foot *1) will return to where it was before threading mode was started.

*1: The intermittent presser foot is only applicable to -484 SF specifications.

4-3. Winding the lower thread

CAUTION

 Do not touch any of the moving parts or press any objects against the machine while winding the lower thread, as this may result in personal injury or damage to the machine.

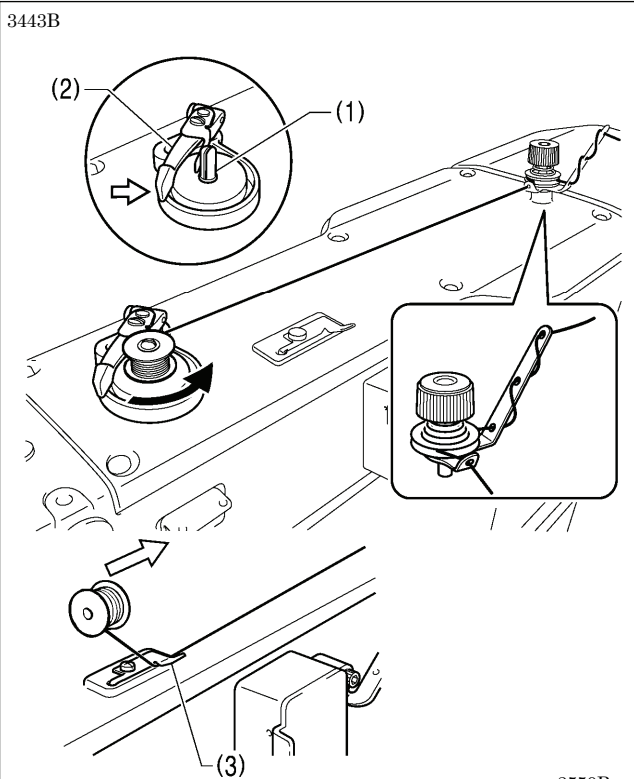

1. Place the bobbin onto the bobbin winder shaft (1).
2. Thread the thread as shown in the illustration, wind the thread around the bobbin several times, and then press the bobbin presser arm (2).
3. Turn on the power.
4. Lower the work clamps (and the intermittent presser foot) before depressing the start switch. Home position detection will be carried out.
5. Touch the Wind key (4) on the screen.
6. The display will switch to the thread winding mode screen.
7. Check that the needle does not touch the work clamps (and the intermittent presser foot), and then lower the work clamps (and the intermittent presser foot) before depressing the start switch.
8. Keep depressing the start switch until the lower thread stops being wound onto the bobbin.
9. Once winding of the set amount of lower thread (80 - 90% of the bobbin capacity) is completed, the bobbin presser arm (2) will return automatically.
10. Remove the bobbin, hook the thread onto the knife (3), and then pull the bobbin in the direction of the arrow to cut the thread.
11. Touch the OK key (5) to return to the previous screen.



3550B

123 : 0000102 0000 / 0000

Type	Program No.	Step No.	Split No.	Speed
Normal / Cycle	103		1	2000

LINE

00000
01891

↑ 100.00 mm
← 150.00 mm

2014/02/20 11:13:88

Wiper	Thread	Clamp
Scale Offset	Slow Start	Wind
101	102	103
Test		



(4)

Wind

1. Place the bobbin onto the bobbin winder shaft (1).
2. Thread the thread as shown in the illustration, wind the thread around the bobbin several times, and then press the bobbin presser arm (2).
3. Check that the needle does not touch the work clamp, and then lower the work clamp before depressing the start switch.
4. Keep depressing the start switch until the lower thread stops being wound onto the bobbin.

1/2

(5) OK

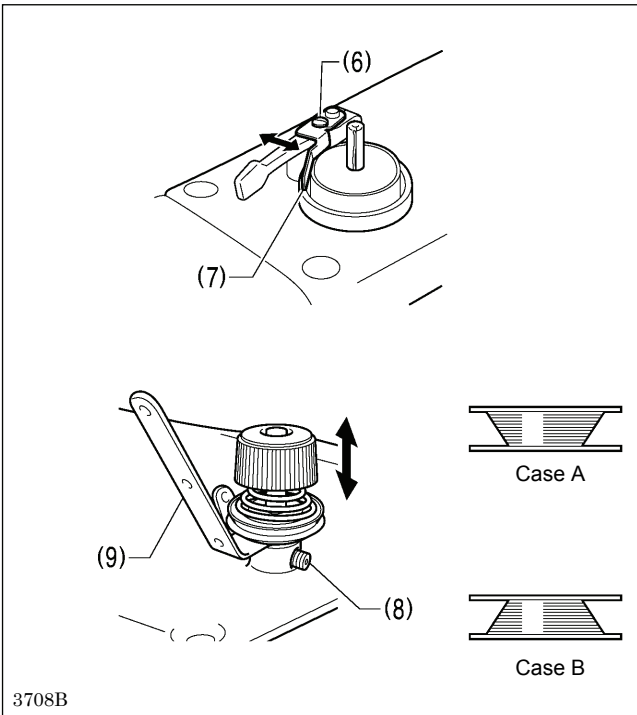

Adjusting the bobbin winding amount
Loosen the screw (6) and move the bobbin presser (7).

If the thread winds onto the bobbin unevenly
Loosen the set screw (8) and move the bobbin winder tension assembly (9) up and down to adjust.

* For case A, move the bobbin winder tension assembly (9) down, and for case B, move it upward.

3708B

4-4. Installing the bobbin case

⚠ CAUTION



Turn off the power switch before installing the bobbin case.

If the foot switch is depressed by mistake, the sewing machine might start operating and injury could result.

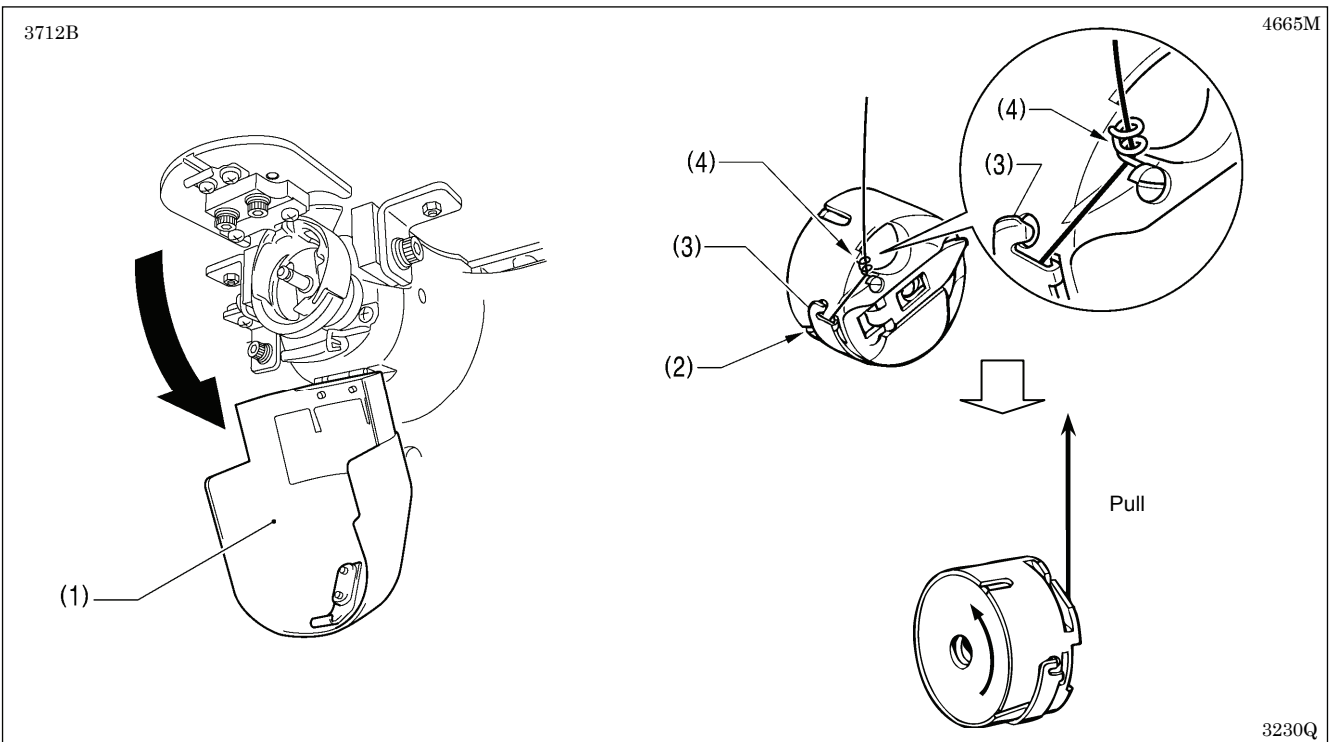

1. Pull the hook cover (1) downward to open it.
2. While holding the bobbin so that the thread winds to the left, insert the bobbin into the bobbin case.
3. Pass the thread through the thread slot (2), pass it underneath the spring (3), and then pass it through the thread guide (4), leaving a trailing-out length of about 30 mm.
4. Hold the latch on the bobbin case and insert the bobbin case into the rotary hook.

4-5. Installing the anti-spin spring

If the following situations occur, operation can be improved by using an anti-spin spring.

- The lower thread becomes tangled inside the bobbin case
- Uneven thread tightening occurs at the sewing start

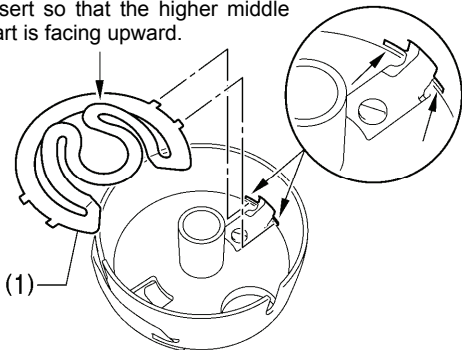
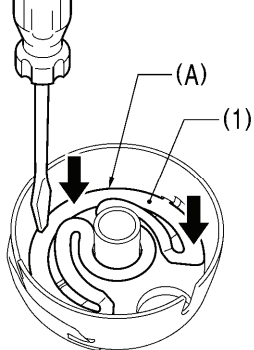
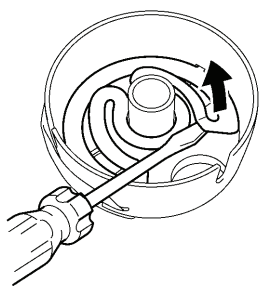
<p>Installation</p> <p>1. While inserting the projections on the anti-spin spring (1) into the grooves of the bobbin case, insert the anti-spin spring (1). Insert so that the higher middle part is facing upward.</p>  <p>2. Push the anti-spin spring (1) to insert it securely so that it does not lift up above the inside edge (A) of the bobbin case.</p> 	<p>Removal</p> <p>Use the tip of a screwdriver or similar to remove as shown in the illustration.</p> 
4715M	4716M

4-6. Thread tension

[Thread tension reference]

Upper thread	#4 or similar
Lower thread	#4 or similar
Upper thread tension (N)	2.5 – 3.0
Lower thread tension (N)	1.0 – 1.5
Pre-tension (N)	0.3 – 0.6
Needle	DP x 17 #25
Normal sewing speed	1,300 sti/min

4-6-1. Lower thread tension

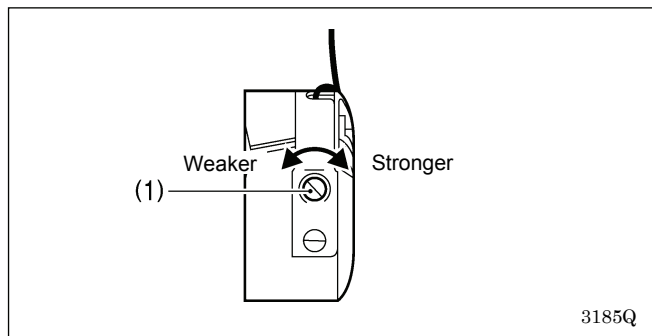

Adjust the lower thread tension by turning the adjusting screw (1).

4-6-2. Upper thread tension

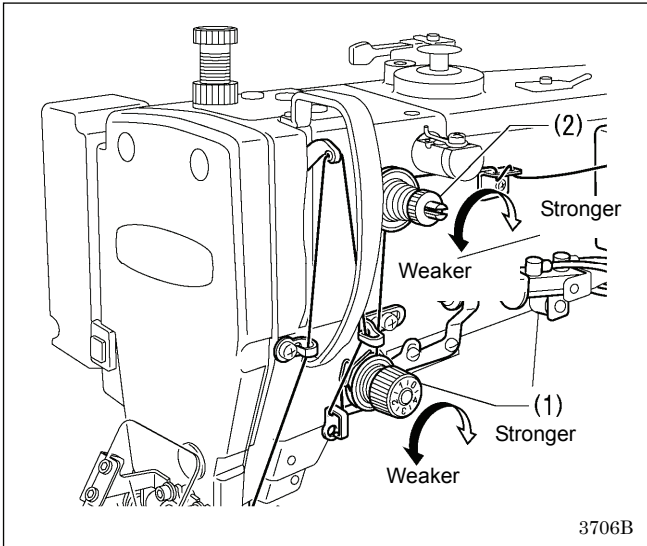

1. Turn the tension nut (1) (main tension) to adjust the tension as appropriate for the material being sewn.
2. Use the tension nut (2) (sub tension) to adjust so that the upper thread trailing length after thread trimming is about 45 mm.

4-7. Starting up

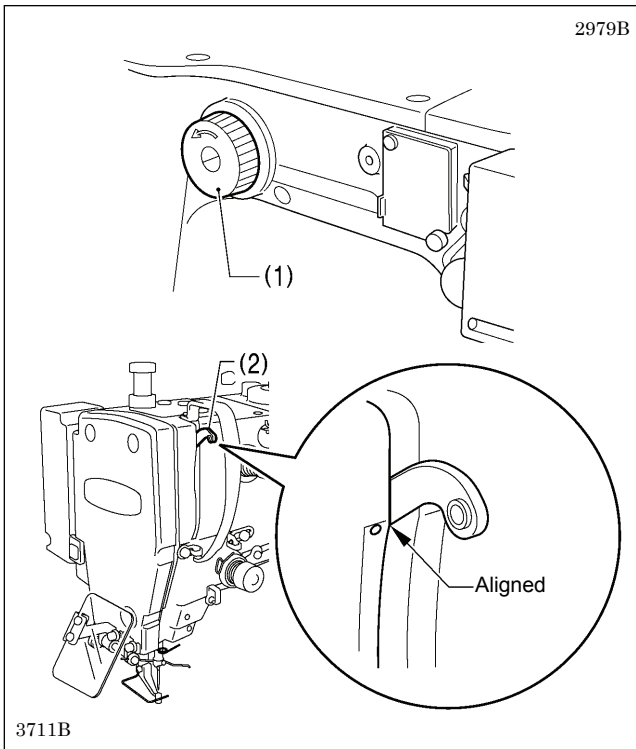

Before turning on the power, check that the needle bar is at the needle up stop position.

Turn the pulley (1) in the direction of the arrow until the ridge at the bottom of the thread take-up (2) is aligned with the index mark.

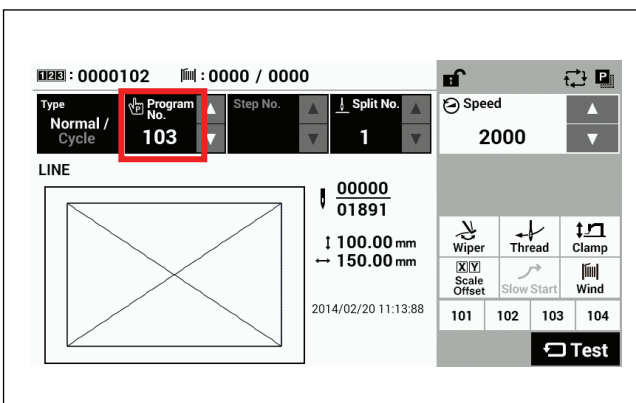

Turn on the power.

If a program has been registered, the program number and a preview of the sewing pattern will be displayed.

No programs are registered at the time of shipment from the factory, and so "----" is displayed as the program number (No.).

For details on the sewing data reading method, refer to "6. USING STORAGE MEDIA".

5. USING THE LCD PANEL (BASIC OPERATIONS)

⚠ CAUTION



To prevent problems, do not use objects with sharp points to operate the LCD panel.

5-1. Name and function of each LCD panel item

5-1-1. Main names and functions

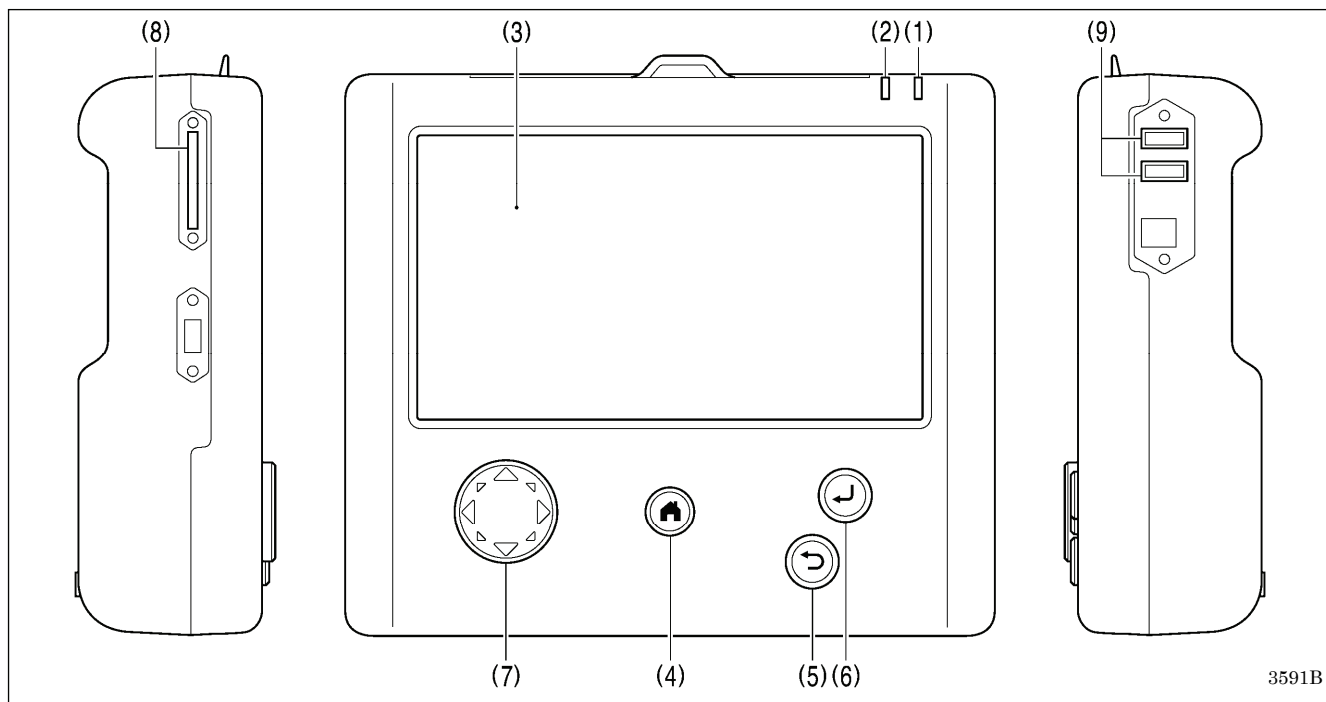

(1) Power indicator	Illuminates when the power is turned on.
(2) Caution indicator	Illuminates when an error occurs.
(3) LCD/touch panel	This displays messages and touch keys (icons).
(4) HOME key	This key is used to return to the home screen. At the home screen, hold down (for 2 seconds or more) to switch to sleep mode*.
(5) BACK key	This key is used for operations such as returning to the previous step and canceling settings.
(6) ENTER key	This key is used for operations such as confirming settings.
(7) JOG key	This key is used when programming sewing data.
(8) SD card slot	Insert an SD card.
(9) USB port×2	Connect a USB memory or other device.

* The screen will turn off and the sewing machine cannot be operated. Press the HOME key once more to cancel sleep mode.

5-1-2. Home screen

Press the HOME key to display the [home screen].

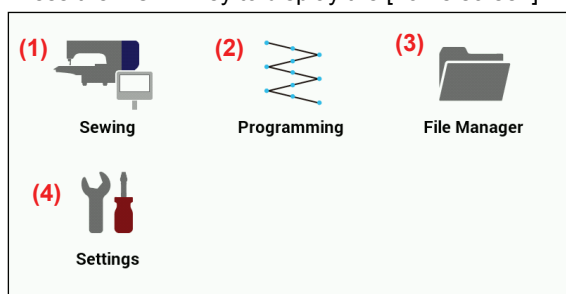

(1) Sewing key	Touch to switch to the [sewing operation screen].
(2) Programming key	Touch to switch to the [programming screen].
(3) File Manager key	Touch to switch to the [file manager screen].
(4) Settings key	Touch to switch to the [setting menu screen].

5-1-3. Sewing operation screen

- When the power is turned on while the LCD panel is connected to the sewing machine, this screen is displayed automatically.
- If any other screen is being displayed, touch the sewing key in the home screen to display this screen.

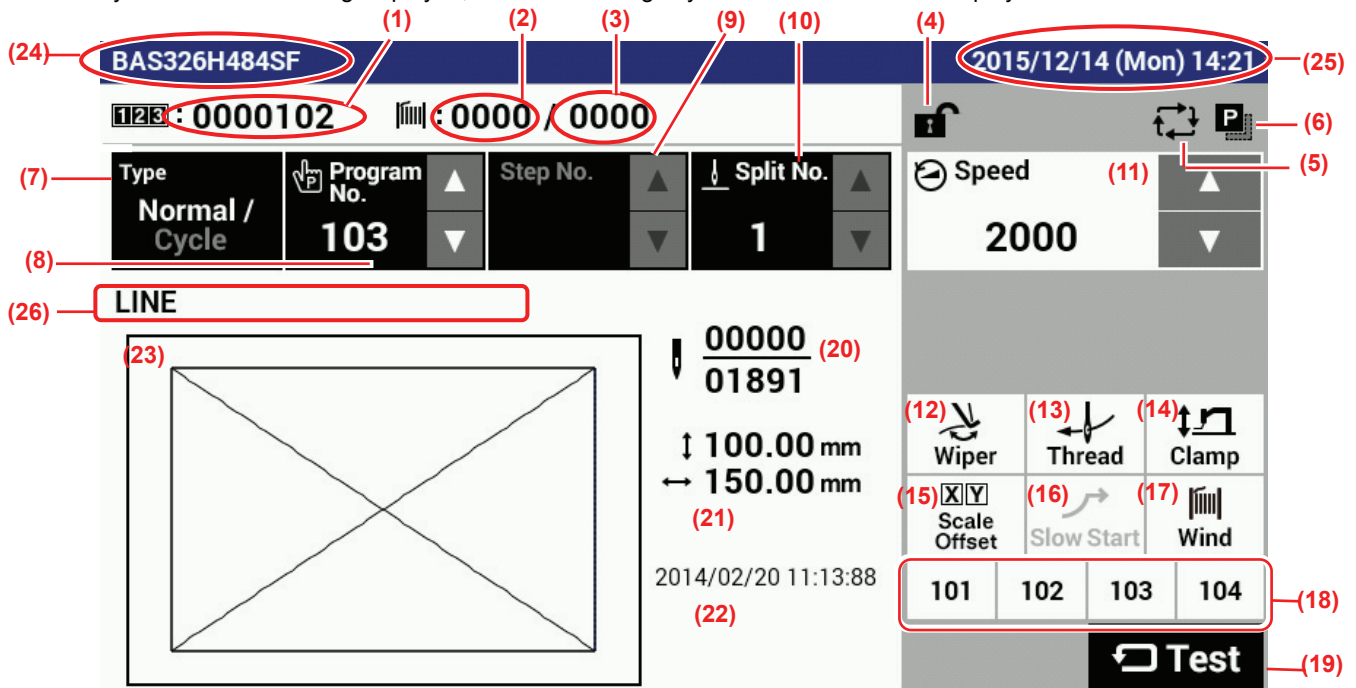

(1) Production counter key	This shows the production counter value. If you keep pressing this key, the display switches to the setting menu screen.
(2) Lower thread counter key	This shows the lower thread counter value. If you keep pressing this key, the display switches to the setting menu screen.
(3) Lower thread setting key	Displays the lower thread setting value. If you keep pressing this key, the display switches to the setting menu screen.
(4) Screen lock key	Touch this key to switch the home screen between locked and unlocked.
(5) Cycle program key	Touch to switch to the cycle program editing screen.
(6) Copy key	Touch to switch to the sewing program copying screen.
(7) Type key	Touch to switch the program type.
(8) Program No. keys	Touch to display/select the current program number.
(9) Step No. keys	Touch to display/select the current step number.
(10) Split No. keys	Touch to display/select the current split number.
(11) Tension keys	Touch to display/select the digital tension value.
(12) Wiper key	Touch to switch the thread wiper on/off.
(13) Thread key	Touch to switch to the threading screen.
(14) Clamp key	Touch to switch to the Adjust Clamp Height setting screen.
(15) Scale Offset key	Touch to switch to the Scale/Offset setting screen.
(16) Slow Start key	Touch to switch to the Slow Start setting screen.
(17) Wind key	Touch to switch to the thread winding screen.
(18) Direct selection keys	You can register normal/cycle program numbers into each of these keys. When you touch a key, the program assigned to that key is selected.
(19) Test key	Touch to switch to test mode.
(20) Current stitch number / Total number of stitches	Shows the current stitch number and the total number of stitches.
(21) Sewing area size	Shows the size of the sewing data area.
(22) Sewing data information	Shows information about the sewing data.
(23) Preview	Shows a preview of the sewing data.
(24) Model name	Shows the model name and specifications.
(25) Date and time	Shows the current date and time.
(26) Comments	Shows comments about the sewing data.

5-2. Parameter setting method

Parameter settings are made at the [sewing operation screen].

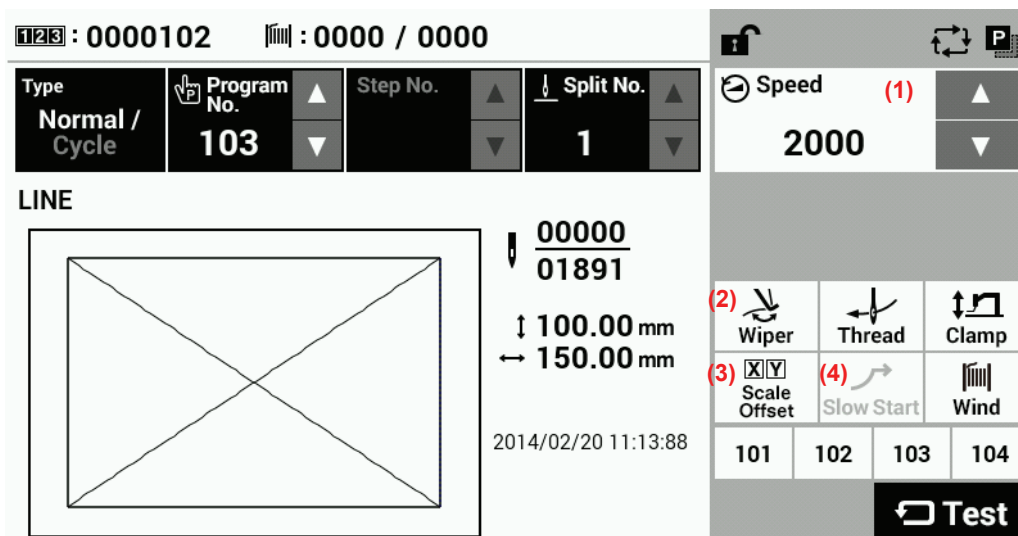

Sewing speed

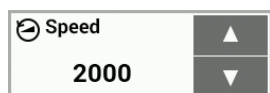

Use the Speed Δ and ∇ keys (1) to make the setting.

- Setting range: 200 sti/min - 2,200 sti/min 100 sti/min units Initial value: 2,000 sti/min

Thread wiping



Touch the Wiper key (2) to turn the wiper on or off. (The initial setting value is off.)
When the setting is on, the key is displayed in blue.

X/Y-scale, X/Y-offset



Touch the Scale Offset key (3) to display the Scale/Offset setting screen.

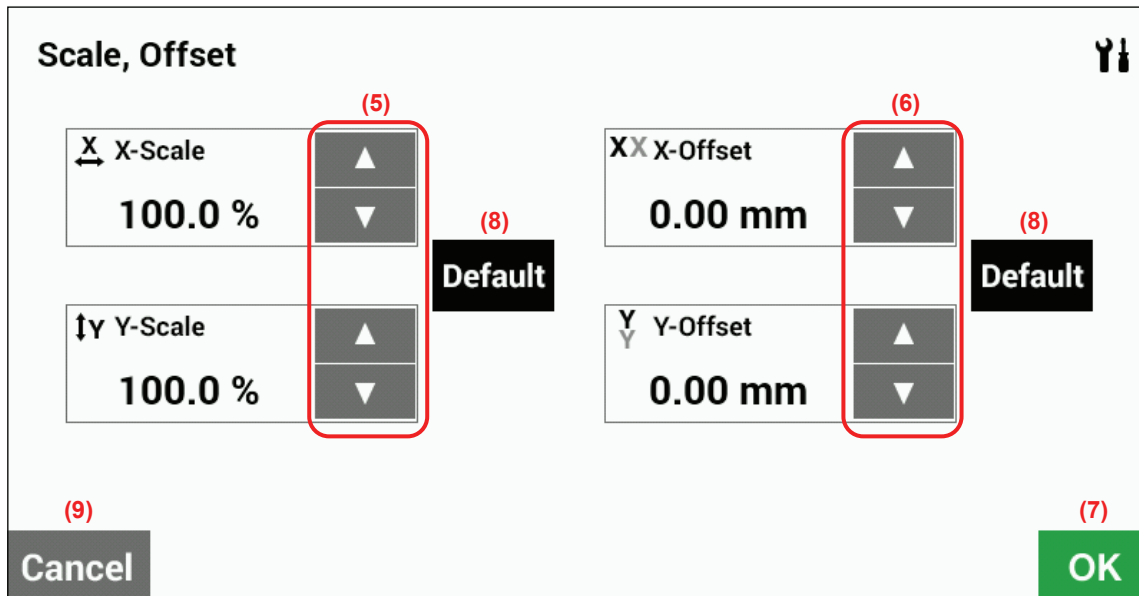

- X-Scale, Y-Scale (5) 0 - 400%, 0.1% units
Limited by available sewing area.
- X-Offset, Y-Offset (6) 0 - (size of sewing machine sewing area) mm, 0.05 mm units
When activating the offset, first lower the work clamps (and the intermittent presser foot) and depress the start switch to carry out home position detection.
- Touch the OK key (7) to confirm the setting and return to the previous screen.
- Touch the Default key (8) to return the setting to the initial value.
Initial values: X/Y-scale = 100%, X/Y-offset = 0 mm
- Touch the Cancel key (9) to return to the previous screen without changing the setting.

5. USING THE LCD PANEL (BASIC OPERATIONS)

Slow start pattern



Set memory switch No. 100 to "ON" and then touch the Slow Start key (4) to display the slow start setting screen.

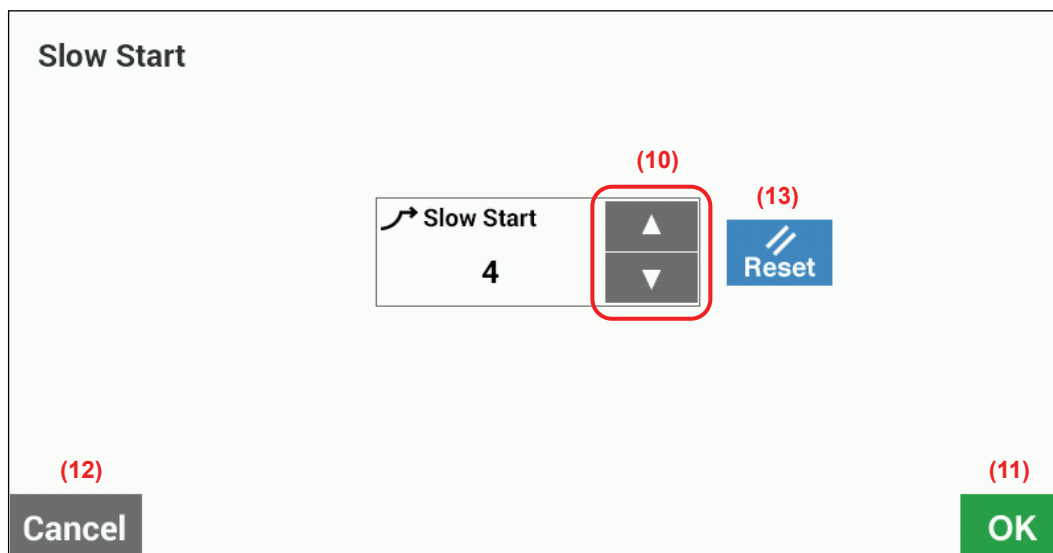

- Touch the Δ or ∇ key (10) to adjust the starting-up speed at the sewing start.
- Touch the OK key (11) to confirm, or touch the Cancel key (12) to return to the [sewing operation screen] without changing the setting.
- Touch the Reset key (13) to return the setting to the initial value.
 - * The smaller the number, the slower the start.
 - * This is used to stop the thread from pulling out at the sewing start, and at times when skipped stitches might easily occur.

Lo	1	2	3	4	5	6	7	8	9
Sewing speed for 1st stitch	200	200	300	400	400	400	400	600	800
Sewing speed for 2nd stitch	200	300	400	400	500	600	800	1000	1200
Sewing speed for 3rd stitch	300	400	500	600	800	1000	1200	1600	*1
Sewing speed for 4th stitch	500	600	700	900	1200	1400	*1	*1	*1

*1 Sewing will be carried out at the sewing speed which is set by the parameters.

- * For details on the sewing data reading method, refer to "6. USING STORAGE MEDIA".
- * When memory switch No. 400 is set to ON, the X-scale, Y-scale, sewing speed and intermittent presser foot height can be recorded separately for each program number.
- * When memory switch No. 100 and No. 400 are set to ON, slow start patterns can be recorded separately for each program number.
- * For details on memory switches, refer to "2-1. Memory switch setting method" in the "LCD Panel/Operation Panel" Instruction Manual. (*1).

(*1) Please download the "LCD Panel/Operation Panel" Instruction Manual from our web site.

5-3. Copying programs

[Sewing operation screen]

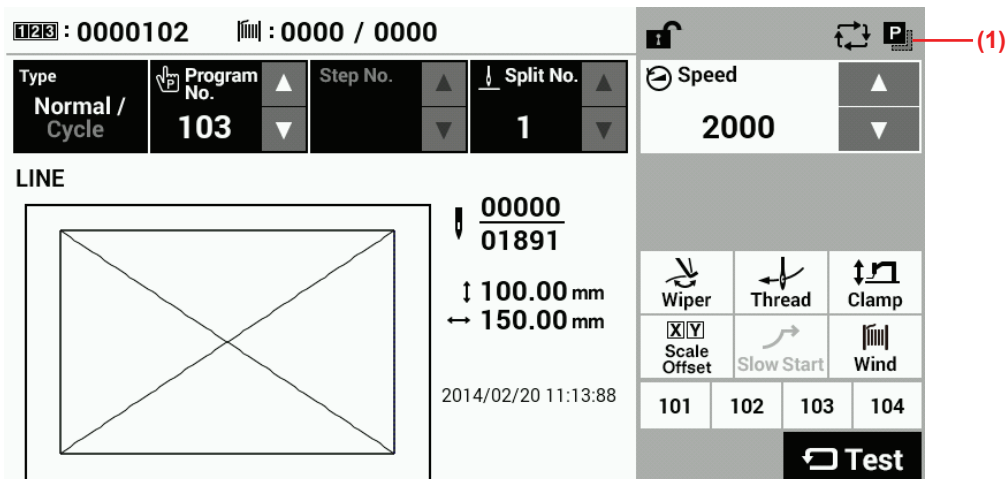

Touch the Copy key (1) to switch to the [program copy screen].

[Program copy screen]

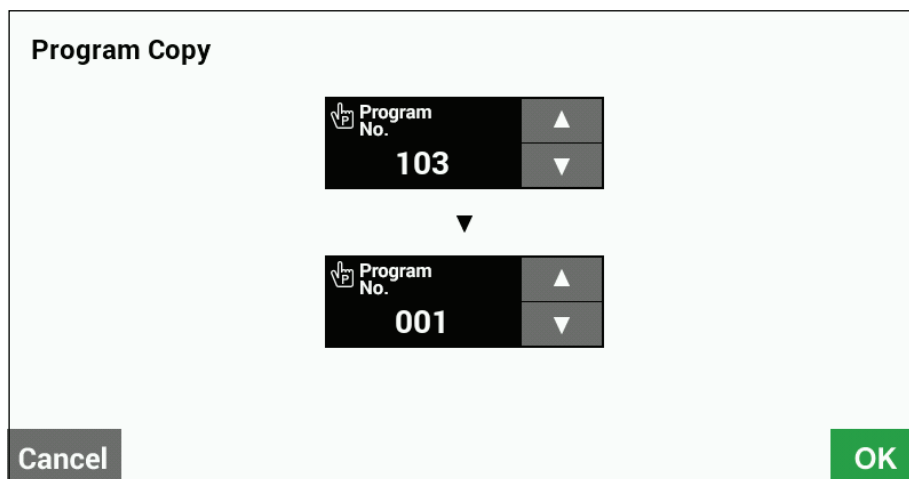

Select the copy source program No. and the copy destination program No.

Touch the OK key to carry out copying. After copying, the display will return to the previous screen.

Touch the Cancel key to return to the previous screen without copying.

5-4. Checking the sewing pattern

Use test feed mode to operate the feed mechanism in order to check the needle movement.
Check that the needle hole does not come out from the frame of the work clamps.

1



The Test key is displayed in blue.

[Sewing operation screen]

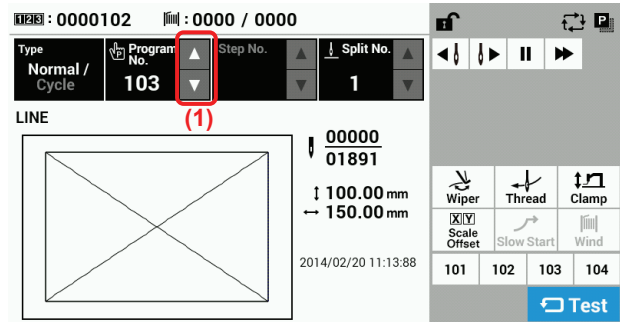

1. Touch the Test key at the [sewing operation screen].
2. Touch the Δ or ∇ key (1) to set the program number that you would like to check.
3. Lower the work clamps (and the intermittent presser foot) before depressing the start switch.
Home position detection will be carried out.

2

Continuous test feed

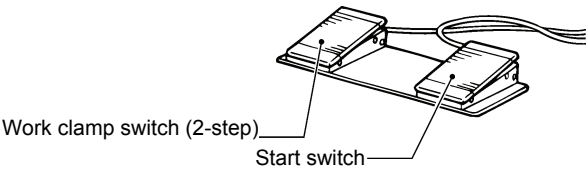

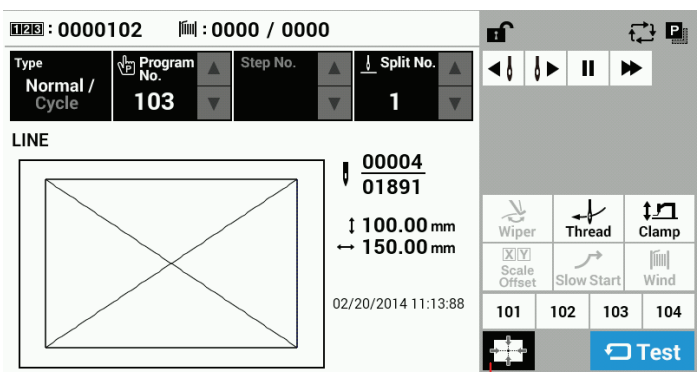

Work clamp switch (2-step)

Start switch

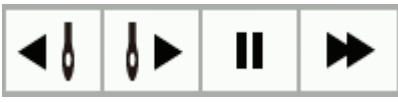

Single stitch check



1. If you lower the work clamps (and the intermittent presser foot) and then depress the start switch, the feed mechanism starts moving continuously one stitch at a time.
(The stitch number display will be decremented by one stitch at a time.)
2. When the feed reaches the end of the pattern, it stops.
 - If you would like to stop the feeding operation, touch the Continuous feed stop key. 
 - Touch the Move to sewing start key (2) to return to the sewing start.



Touch to move back by one stitch.



Touch to move forward by one stitch.



Fast-forward

4923Q

36

BAS-326H-484, BAS-326H-484 SF

5-5. Setting the intermittent presser foot lift amount (BAS-326H-484 SF specifications only)

The settings for the intermittent presser foot lift amount can be changed at the [sewing operation screen].

[Sewing operation screen]

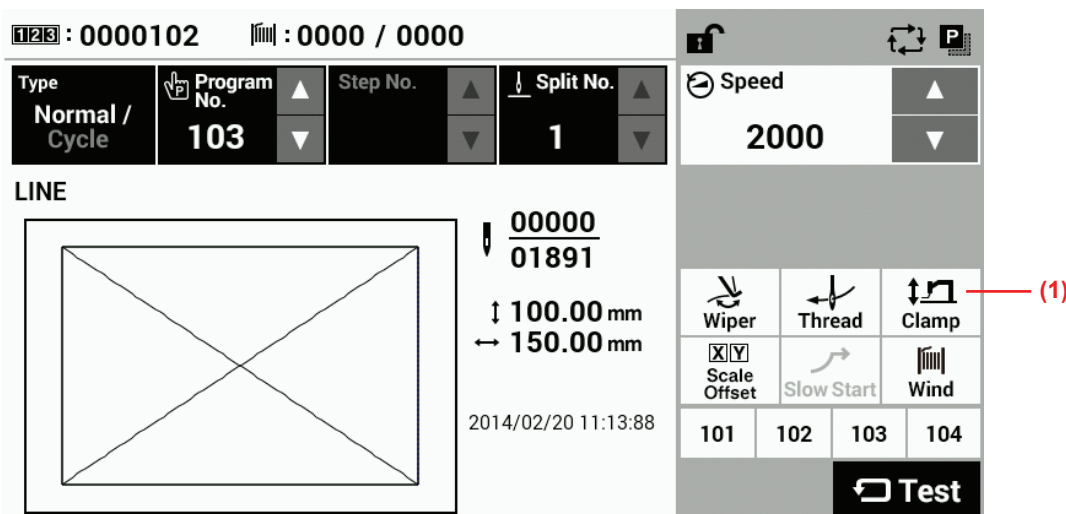

Touch the Clamp key (1) to display the Adjust Clamp Height setting screen.

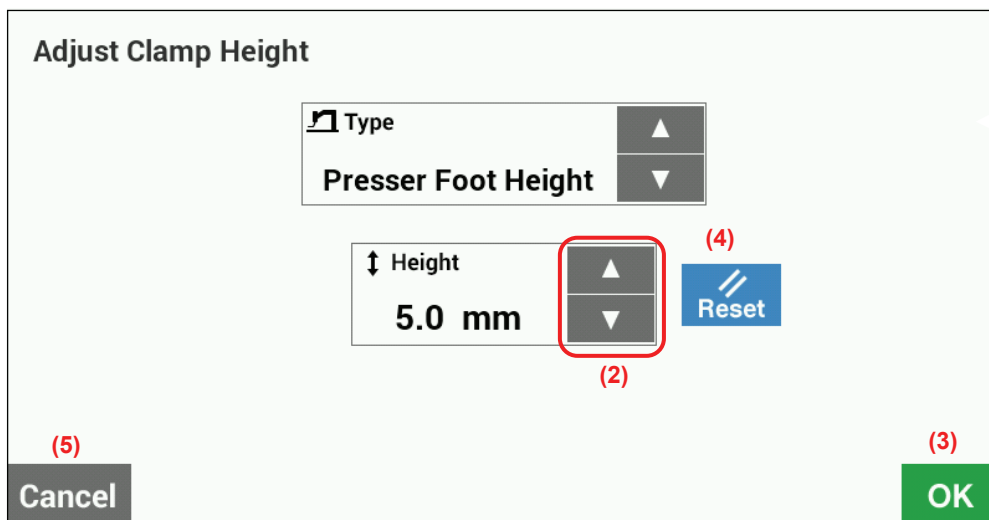

- Intermittent presser foot height setting
 - If you use the Height keys (2) to change the Height value, the sewing machine's intermittent presser foot will move.
(setting range: 0.0 - 10.0 initial value: 5.0)
 - Touch the OK key (3) to confirm, or touch the Cancel key (5) to return to the [sewing operation screen] without changing the setting.
 - Touch the Reset key (4) to return the value which currently appears in the display to the value which was first displayed when you switched to the setting screen. The sewing machine's intermittent presser foot will operate according to this value.

Intermittent presser foot operation

① **Intermittent presser foot lift amount**
 ② **Intermittent presser foot height**
 The settings can be made by the above operations.
 However, set the intermittent presser foot height to a higher setting than the intermittent presser foot stroke.
 * If it is set smaller, the intermittent presser foot will come into contact with the needle plate.
 ③ **Intermittent presser foot stroke**
 Refer to "Adjusting the intermittent presser foot (-484 SF specifications only)" in the Instruction Manual when making the adjustment. (*1)

3713B

(*1) Please download the Instruction Manual for the sewing machine from our web site.

6. USING STORAGE MEDIA

⚠ CAUTION



Do not connect anything to the USB port other than the USB memory. If this is not observed, problems with operation may result.
To prevent problems, do not use objects with sharp points to operate the LCD panel.

6-1. Notes on handling



[SD]

- Compatible cards: SD (max. 2 GB), SDHC (max. 32 GB)
- Compatible file formats: FAT16, FAT32

[USB Memory]

- Compatible file formats: FAT16, FAT32
- Max. size: 32 GB

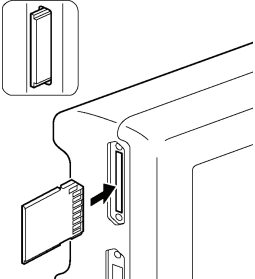
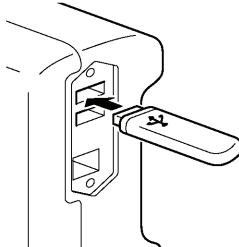
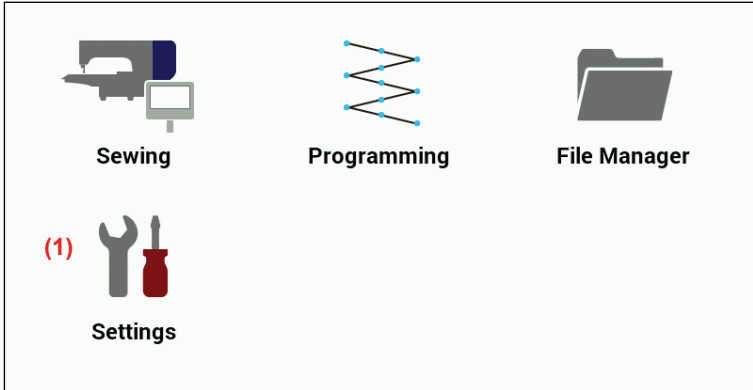
6-2. Importing and exporting data

1	<div style="display: flex; justify-content: space-around;"> <div style="text-align: center;"> <p>SD card slot</p>  </div> <div style="text-align: center;"> <p>USB port</p>  </div> </div>	<p>Insert an SD card or USB memory.</p> <p>NOTE:</p> <ul style="list-style-type: none"> • Make sure that the media is facing the correct way when inserting it. • Always be sure to keep the cover closed except when inserting and removing the media, otherwise dust may get inside and cause problems with operation. <p style="text-align: right;">3592B 3593B</p>
2	<p>[Home screen]</p>  <p>[Setting menu screen]</p> 	<ul style="list-style-type: none"> • Press the HOME key to switch to the [home screen]. • Touch the Settings key (1) to switch to the [setting menu screen]. <ul style="list-style-type: none"> • If you select "Data Management" > "Import (Storage Media to Panel)", the display switches to the [import screen]. If you select "Data Management" > "Export (Panel to Storage Media)", it switches to the [export screen].

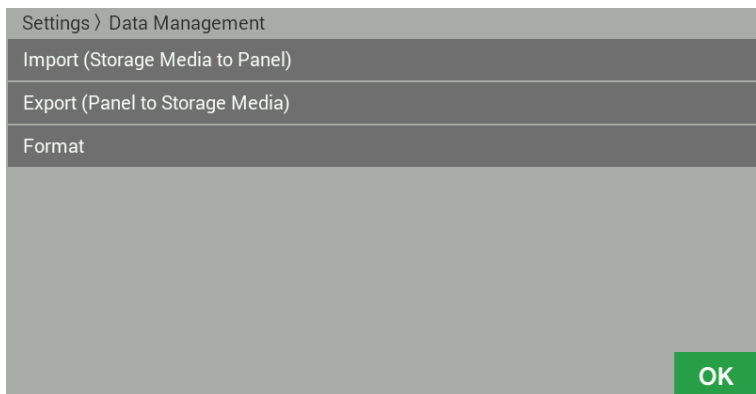

3

Select the items to be imported or exported, and then touch the OK key (2).

[Import screen]

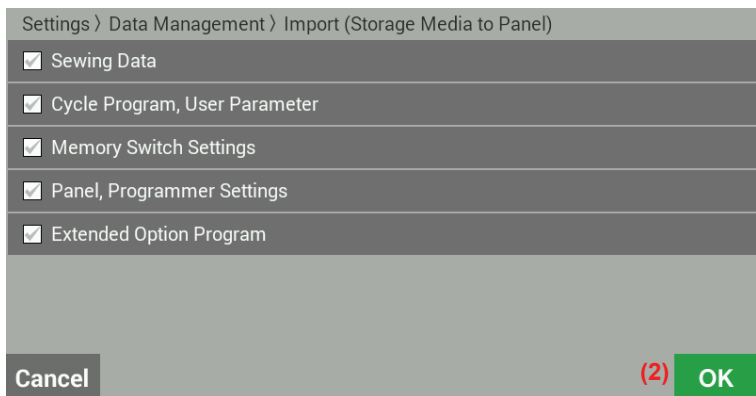

[Items to import]

- Sewing Data
- Cycle Program, User Parameter
- Memory Switch Settings
- Panel, Programmer Settings
- Extended Option Program

* To select and import only part of the sewing data, refer to the procedure in 6-3.

[Export screen]

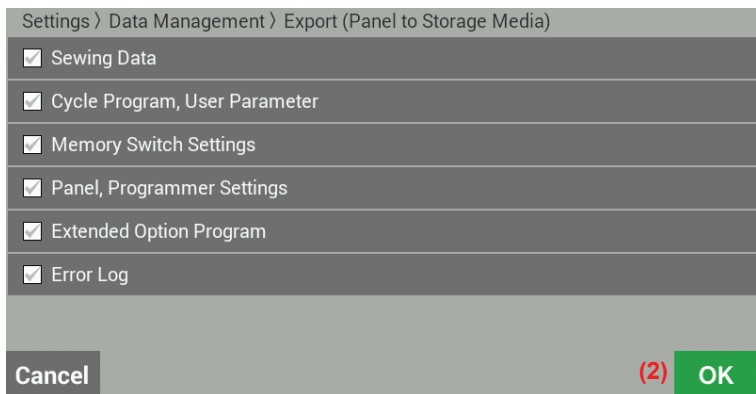



[Items to export]

- Sewing Data
- Cycle Program, User Parameter
- Memory Switch Settings
- Panel, Programmer Settings
- Extended Option Program
- Error Log

6-3. Importing items of sewing data separately

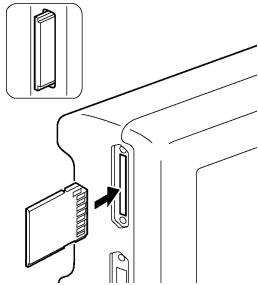
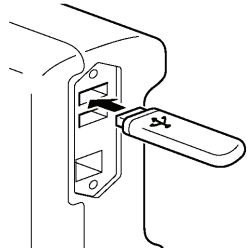
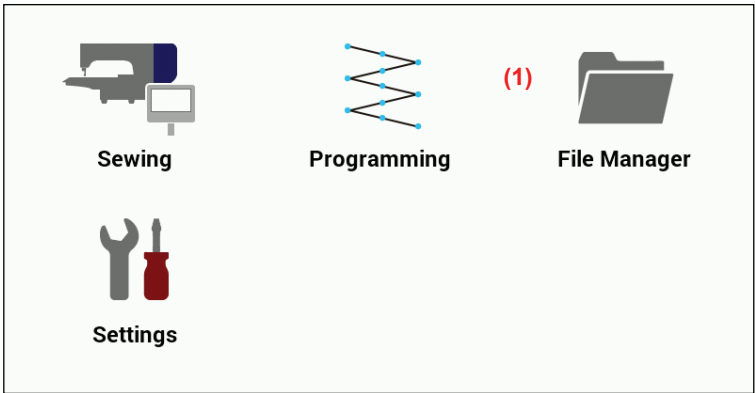
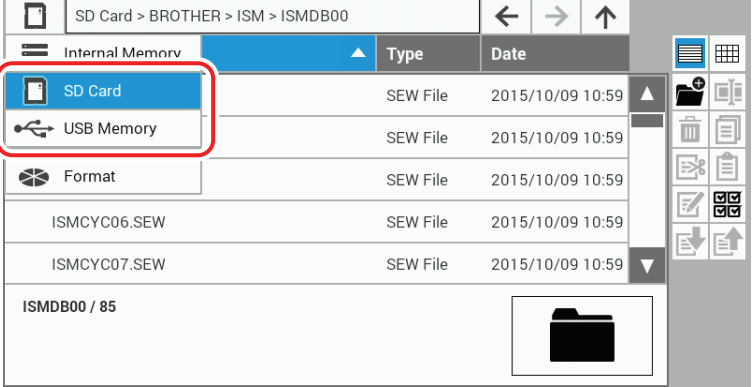
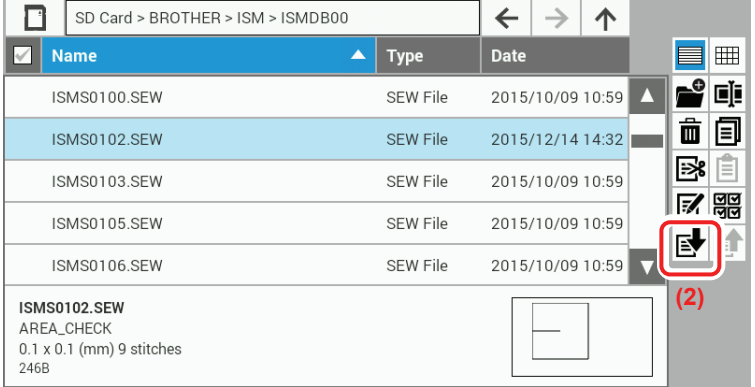
If you would like to import sewing data separately, do it from the [file manager screen]. Folders are not specified.

<p>1</p>	<div style="display: flex; justify-content: space-around;"> <div style="text-align: center;"> <p>SD card slot</p>  </div> <div style="text-align: center;"> <p>USB port</p>  </div> </div>	<p>Insert an SD card or USB memory.</p> <p>NOTE:</p> <ul style="list-style-type: none"> • Make sure that the media is facing the correct way when inserting it. • Always be sure to keep the cover closed except when inserting and removing the media, otherwise dust may get inside and cause problems with operation. <p style="text-align: right;">3592B 3593B</p>
<p>2</p>	<p>[Home screen]</p>  <p>[File manager screen]</p> 	<ul style="list-style-type: none"> • Press the HOME key to switch to the [home screen]. • If you touch the File manager key (1), the display will switch to the [file manager screen]. • Touch the media key in the top-left corner to select "SD Card" or "USB Memory". The display will switch to the respective main folder.
<p>3</p>		<ul style="list-style-type: none"> • Select the files to be imported and then touch the import key (2). * If you would like to select multiple files, you can select files in multiple select mode.  <p>Touch to switch between multiple select and single select mode.</p>

* For details on other functions, please contact the place of purchase.

7. SEWING

! WARNING



Do not allow any liquids to get onto this sewing machine, otherwise fire, electric shocks or operating problems may occur.



If any liquid gets inside the sewing machine (machine head or control box), immediately turn off the power and disconnect the power plug from the electrical outlet, and then contact the place of purchase or a qualified technician.

! CAUTION



Turn off the power switch at the following times.

If the foot switch is depressed by mistake, the sewing machine might start operating and injury could result.

- When replacing the bobbin and needle
- When not using the machine and when leaving the machine unattended



Do not touch any of the moving parts or press any objects against the machine while sewing, as this may result in personal injury or damage to the machine.

7-1. Sewing

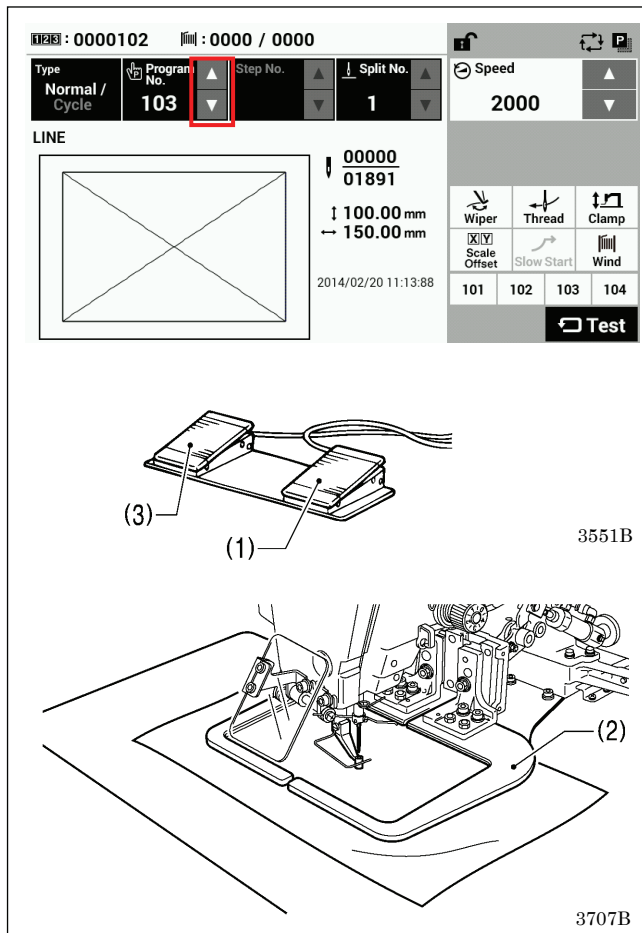

1. Turn on the power.
2. Touch the Δ or ∇ key to select the number for the program to be sewn.
* For details on reading sewing data from SD cards and USB memory devices, refer to "6-3. Importing items of sewing data separately".
3. Lower the work clamps (2) and depress the start switch (1).
Home position detection will be carried out.
4. Place the materials under the work clamps (2).
5. Depress the work clamp switch (3).
The work clamps (2) will be lowered.
6. Depress the start switch (1).
The sewing machine will start sewing.
7. After sewing is completed, the thread trimmer will operate. And then the work clamps (2) will be raised.

Use work clamps which will hold the material securely so that it does not slip. If the material slips when using the standard work clamps and feed plate, process them so that the material does not slip.

7-2. Using the STOP switch

If you press the emergency stop switch (1) to during actual sewing, an error dialog box will be displayed and the sewing machine will immediately stop.

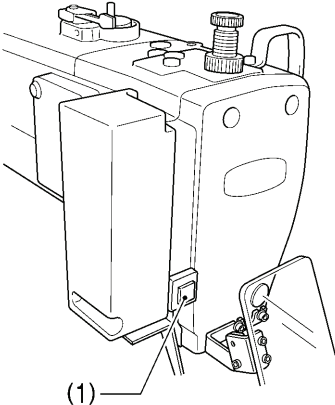

3111B

! E011

The STOP switch was pressed. Press the RESET key to clear the error. You can touch the keys on the LCD panel to move the feed in order to continue sewing. (Subcode = 1)

(2) 



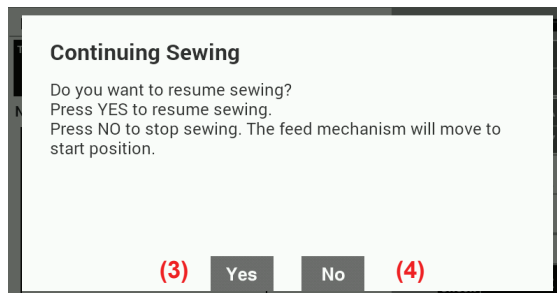

<Clearing>

1. Touch the Reset key (2).
 - The thread will be trimmed, and then the error dialog box on the screen will disappear and the buzzer will stop.
2. A dialog box asking you to confirm if you want to continue sewing will be displayed.

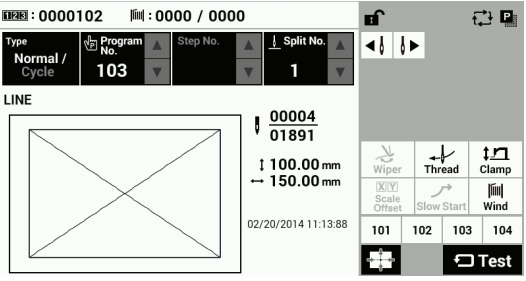
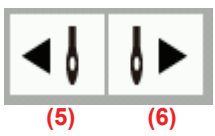

<Continuing sewing from a stopping point>

If the thread breaks or the lower thread runs out during sewing, you can then continue sewing from the point where the thread broke or ran out.

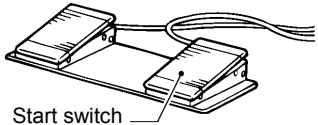
1		<p>Touch "Yes" (3) to switch to the resewing standby screen.</p>
2		<p>Touch the  keys (5) and (6) on the screen to return to the position where sewing is to be resumed.</p> <p>When you touch the  key (5), the feed will move backward by 1 stitch, and when you touch the  key (6), the feed will move forward by 1 stitch.</p>
3	 <p>Start switch</p>	<p>Depress the start switch. The sewing machine will start operating and sewing will start.</p>

3655B

<Returning to the sewing start position without continuing sewing>

If you do not wish to continue sewing, touch "No" (4).

- After home position detection is carried out, the mechanism will return to the sewing start position.



お手入れや標準調整など、更に詳しい内容は、「取扱説明書」をご覧ください。
取扱説明書、パーツブック、押え板加工図、送り板加工図は、弊社 Web サイトからダウンロードしてください。

For cleaning, standard adjustments and more details, please refer to the download version of the Instruction Manual.
Download the Instruction Manual, Parts Book, work clamp processing diagram and feed plate processing diagram from our web site.

保养、标准调整等详细内容、请浏览下载版的使用说明书。
使用说明书、零部件手册、压脚板加工图、送布板加工图请从本公司网站下载。

Para limpiar, realizar ajustes estándar y otros detalles, consulte el manual de instrucciones de la versión de descarga.
Descargue el manual de instrucciones, el libro de partes, el diagrama de procesamiento del prensor del tejido y el diagrama de procesamiento de la placa de alimentación desde nuestro sitio en Internet.

日本 / Japan / 日本 / Japón URL: <http://www.brother.co.jp/product/ism/index.htm>

中国 / China / 中国 / China URL: <http://www.brother.cn/cn/ism/ism.html>

アジア / Asia / 亚洲 / Asia URL: http://www.brother.com/as_oc/ism/

南北アメリカ / Americas / 美洲 / América URL: <http://www.brother-usa.com/Support/>

ヨーロッパ、中東、アフリカ /
Europe, Middle East and Africa /
欧洲、中东和非洲 /
Europa, Oriente Próximo y África URL: <http://www.brother-industrial.com/>

- * 製品改良のため、本書の内容の一部がお買い上げの製品と異なる場合がありますのでご了承ください。
- * Please note that the contents of this manual may differ slightly from the actual product purchased as a result of product improvements.
- * 请注意: 由于产品改进, 本手册内容可能会与实际购买的产品略有出入。
- * Tenga en cuenta que como resultado de mejoras en el producto el contenido de este manual puede variar ligeramente del producto que ha comprado.

ブラザー工業株式会社 <http://www.brother.co.jp/>
〒448-0803 刈谷市野田町北地蔵山1番地5 TEL: 0566-95-0085
BROTHER INDUSTRIES, LTD. <http://www.brother.com/>
1-5, Kitajizoyama, Noda-cho, Kariya 448-0803, Japan. Phone : 81-566-95-0088

© 2015 Brother Industries, Ltd. All Rights Reserved.

BAS-326H-484, BAS-326H-484 SF
SB6873-001
2015.12. B (1)

This is the original instructions.
Este es el original de las instrucciones.



SB6873001
使用说明书