



Brother Industries, Ltd.
15-1, Naeshiro-cho, Mizuho-ku, Nagoya 467-8561, Japan

Thank you for choosing Brother. Your support is important to us and we value your business. Your Brother product is engineered and manufactured to the highest standards to deliver reliable performance, day-in and day-out.

Please read the Product Safety Guide on page 20 before you set up your machine. Then, please return to this page of the Quick Setup Guide for the correct setup and installation procedure.

 WARNING	WARNING indicates a potentially hazardous situation which, if not avoided, could result in death or serious injuries.
 CAUTION	CAUTION indicates a potentially hazardous situation which, if not avoided, may result in minor or moderate injuries.
IMPORTANT	IMPORTANT indicates a potentially hazardous situation which, if not avoided, may result in damage to property or loss of product functionality.
NOTE	Notes tell you how you should respond to a situation that may arise or give tips about how the operation works with other features.



NOTE

Unless otherwise specified, illustrations in this guide show the ADS-1500W.

1

Unpack the machine and check the components

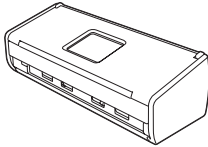
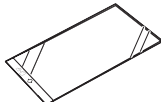
■ The components included in the box may differ depending on your country.

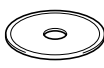
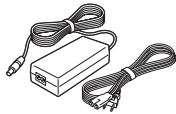
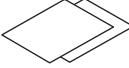
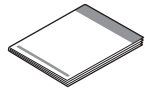
	 Receipt Carrier Sheet for BR-Receipts (USA only)	 USB Interface Cable	 DVD-ROM
 AC adapter	 Product Registration Sheet (USA only) Warranty Card	 Quick Setup Guide	

You can download the *User's Guide* and *Network User's Guide* for your model from the Brother Solutions Center at <http://solutions.brother.com/>. If your computer does not have a DVD-ROM drive, the supplied DVD-ROM does not contain drivers for your operating system, or you want to download manuals and utilities, visit your model page at <http://solutions.brother.com/>.

WARNING

- This product was packaged in a plastic bag. To avoid suffocation, keep plastic bags away from babies and children. Do not use the bag in cribs, beds, carriages, or play pens. The bag is not a toy.
- Use only the AC adapter supplied with this product.

NOTE

- We recommend saving the original packaging in case you must ship your machine.
- Use the supplied USB cable if you want to connect the machine to a computer.

a Remove the protective tape and film covering the machine and the LCD or Control Panel.

b Make sure you have all the components.

2

Connect the AC adapter

NOTE

DO NOT connect the USB cable yet.

- a** Connect the AC adapter.

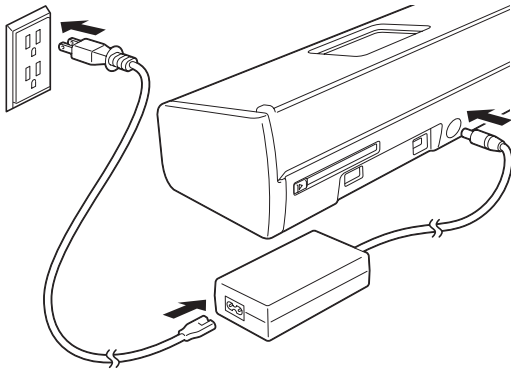

- b** Open the Top Cover **1** and push the flap of the Top Cover **2** firmly back until it clicks.

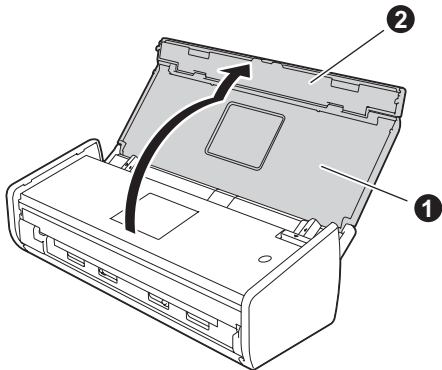

3

Choose your connection type

These installation instructions are for Windows® XP Home, XP Professional, Windows Vista®, Windows® 7, Windows® 8, and Mac OS X v10.6.8, 10.7.x and 10.8.x.

If your computer does not have a DVD-ROM drive or the supplied DVD-ROM does not contain drivers for your operating system, or you want to download manuals and utilities, visit your model page at <http://solutions.brother.com/>. Some software applications included on the DVD-ROM may not be available as a download.

NOTE

Windows® 8 users: If the Brother manuals are in PDF format, use Adobe® Reader® to open them. If Adobe® Reader® is installed on your computer but you cannot open the files in Adobe® Reader®, change the file association for PDF (see *How to open a PDF file in Adobe® Reader® (Windows® 8)* on page 19).

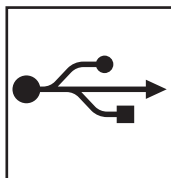
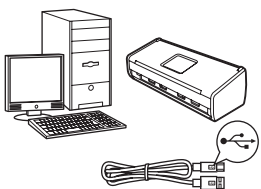

For USB interface cable

Windows®, go to page 4
Macintosh, go to page 6

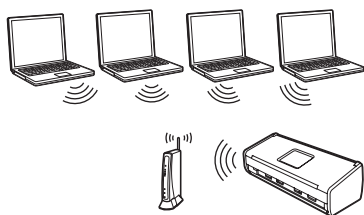

For Wireless Network

Windows® and Macintosh,
go to page 7



For Windows® USB interface users

(Windows® XP Home/XP Professional/Windows Vista®/Windows® 7/Windows® 8)

4 Before you install

Make sure that your computer and machine are ON.

NOTE

- DO NOT connect the USB cable yet.
- If there are any programs running, close them.
- The screens may differ depending on your operating system.
- The DVD-ROM includes Nuance™ PaperPort™ 12SE. This software supports Windows® XP Home (SP3 or greater), XP Professional (SP3 or greater), Windows Vista® (SP2 or greater), Windows® 7 and Windows® 8. Update to the latest Windows® Service Pack before installing MFL-Pro Suite.

5 Install MFL-Pro Suite

- a** Put the DVD-ROM into your DVD-ROM drive. If the model name screen appears, choose your machine. If the language screen appears, choose your language.

NOTE

- If the Brother screen does not appear automatically, go to **Computer (My Computer)**.
(For Windows® 8: click the  (File Explorer) icon on the taskbar, and then go to **Computer**.)
- Double-click the DVD-ROM icon, and then double-click **start.exe**.

- b** Click **Install MFL-Pro Suite**, and then click **Yes** if you accept the license agreements.

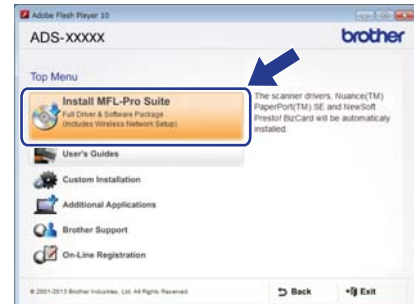

NOTE

For Windows Vista®, Windows® 7 and Windows® 8, when the User Account Control screen appears, click **Allow** or **Yes**.

- c** Choose **Local Connection (USB)**, and then click **Next**.

NOTE

If the **Windows Security** screen appears, select the check box and click **Install** to complete the installation correctly.

- d** Follow the on-screen instructions until the **Plug in the USB cable** screen appears, and then click **Next**.





6 Connect the USB cable

- a Connect the USB cable to the USB port marked with a  symbol on the back of your machine. Connect the other end of the cable to your computer.

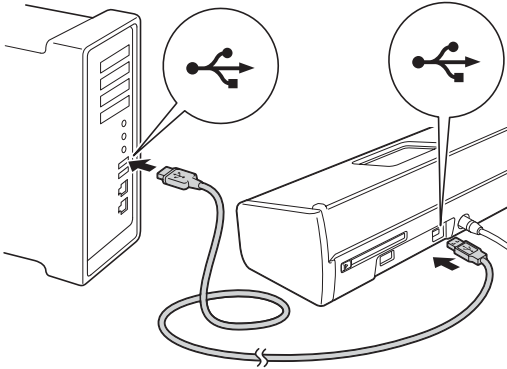

- b The installation will continue automatically. The installation screens appear one after another.

NOTE



DO NOT cancel any of the screens during the installation. It may take a few seconds for all screens to appear.

- c When the **On-Line Registration** screen is displayed, make your selection and follow the on-screen instructions.

7 Finish and restart

- a Click **Finish** to restart your computer.

NOTE

- If an error message appears during the software installation, do one of the following:
 - Windows® XP, Windows Vista® and Windows® 7 users: Run the **Installation Diagnostics** located in  (**Start**) > **All Programs** > **Brother** > **ADS-XXXXX** (where XXXXX is your model name).
 - Windows® 8 users: To run the **Installation Diagnostics**, double-click  (**Brother Utilities**) on the desktop, and then click the drop-down list and select your model name (if not already selected). Click **Tools** in the left navigation bar.
- Depending on your security settings, a Windows® Security or antivirus software window may appear when using the machine or its software. Please allow or permit the window to continue.

- b The following screens will appear:
 - When the **Software Update Setting** screen appears, choose the software update setting you want and click **OK**.
 - When the Brother Product Research and Support Program screen appears, select your preference and follow the on-screen instructions.

NOTE

Internet access is required for the software update and the Brother Product Research and Support Program.

Finish

The installation is now complete and it is time to do a test scan. See *Test Scan (scan to PDF)* on page 18.

To install optional applications:

Now go to

Page 16



For Macintosh USB interface users

(Mac OS X v10.6.8/10.7.x/10.8.x)

4 Before you install

Make sure your machine is connected to the power and your Macintosh is ON.

NOTE

For Mac OS X v10.6.0 to 10.6.7 users, upgrade to Mac OS X v10.6.8 - 10.8.x.

5 Connect the USB cable

NOTE

- DO NOT connect the machine to a USB port on a keyboard or a non-powered USB hub.
- Connect the machine directly to your Macintosh.

a Connect the USB cable to the USB port marked with a  symbol on the back of your machine. Connect the other end of the cable to your computer.

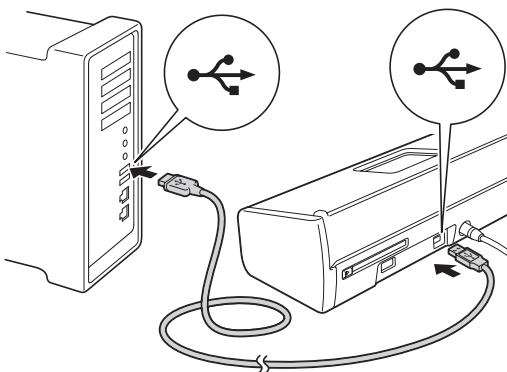

6 Install MFL-Pro Suite

- a** Put the DVD-ROM into your DVD-ROM drive.
- b** Double-click the **Start Here OSX** icon to install. If the model name screen appears, choose your machine.



- c** Choose **Local Connection (USB)**, and then click **Next**. Follow the on-screen instructions.
- d** After the installation, the Brother software will search for the Brother device. This will take a few moments to complete.
- e** Choose your machine from the list, and then click **Next**.

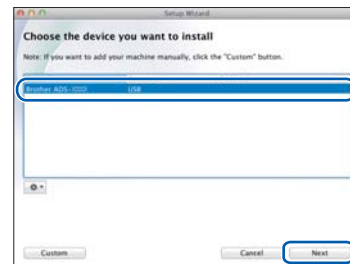

Finish The installation is now complete and it is time to do a test scan. See **Test Scan (scan to PDF)** on page 18.

To install optional applications:

Now go to

Page 17



For wireless network interface users

4 Choose your wireless setup method

The following instructions will offer two methods for setting up your Brother machine on a wireless network. If you want to scan using your mobile devices only and your wireless access point/router supports automatic wireless (one-push) setup (WPS or AOSS™), select method **b**. Otherwise, select method **a**.

a Setup using the DVD-ROM and a USB cable (Windows® and Macintosh)

- We recommend using a computer wirelessly connected to your network for this method.
- You will need to use a USB cable temporarily during configuration.

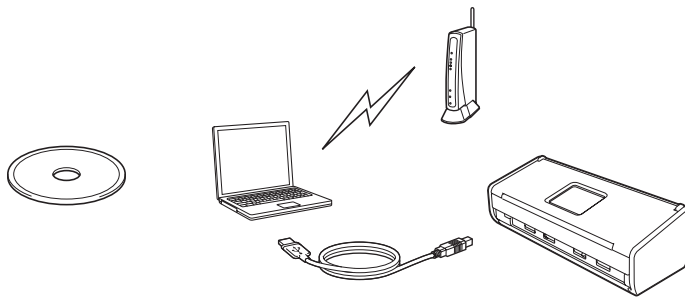

Now go to

page 8

b One-push setup using WPS or AOSS™ (mobile devices)

- Use this method if your wireless access point/router supports automatic wireless (one-push) setup (WPS or AOSS™).
- If you want to scan using your computer, use method **a**.

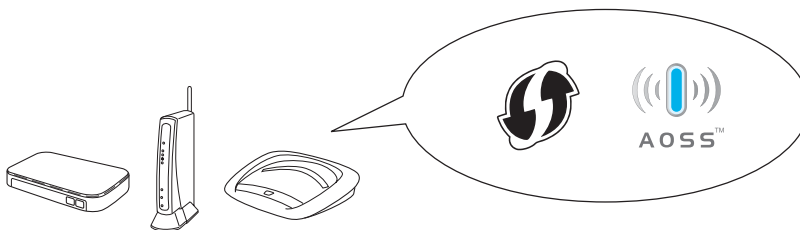

Now go to

page 11



5 Setup using the DVD-ROM and USB cable (Windows® and Macintosh)

For Macintosh Users:

For Macintosh installation, insert the DVD-ROM into your DVD-ROM drive and double-click **Start Here OSX**. Select **Wireless installation** and follow the **Wireless Device Setup** instructions on your computer screen. When setup is complete, go to step **g** on page 10.

For Windows® Users:

- a** Put the DVD-ROM into your DVD-ROM drive. If the model name screen appears, choose your machine. If the language screen appears, choose your language.

NOTE

- If the Brother screen does not appear automatically, go to **Computer (My Computer)**.
(For Windows® 8: click the  (**File Explorer**) icon on the taskbar, and then go to **Computer**.)
- Double-click the DVD-ROM icon, and then double-click **start.exe**.

- b** Click **Install MFL-Pro Suite** and click **Yes** if you accept the license agreements.



NOTE

- For Windows Vista®, Windows® 7 and Windows® 8, when the User Account Control screen appears, click **Allow** or **Yes**.
- Click **Yes** if you accept the license agreements.

- c** Choose **Wireless Network Connection**, and then click **Next**.
- d** When the **Firewall/AntiVirus detected** screen appears, choose **Change the Firewall port settings to enable network connection and continue with the installation. (Recommended)** and click **Next**.

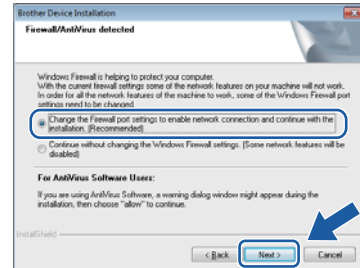

- e** Follow the on-screen instructions to set up the Brother machine.
- f** Your machine will now try to connect to your wireless network. It may take a few minutes.

-  **Wireless setup is now complete.**
The **Wi-Fi light**  on the **Control Panel** lights up, indicating that the machine's **Network I/F is set to WLAN**.

To install MFL-Pro Suite

For Windows® users:

Now go to

Step g on page 9

For Macintosh users:

Now go to

Step g on page 10



- g** Choose your machine from the list, and then click **Next**.

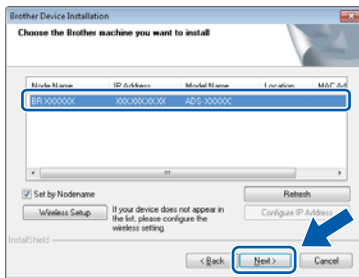

NOTE

- If your machine is not found over the network, confirm your settings by following the on-screen instructions.
- If you are using WEP and the WiFi light  on the Control Panel lights up (for ADS-1000W) or the LCD displays *Connected* (for ADS-1500W) but your machine is not found on the network, make sure you entered the WEP key correctly. The WEP key is case-sensitive.

- h** The installation of the Brother drivers will automatically start. The installation screens appear one after another.

NOTE

- DO NOT cancel any of the screens during the installation. It may take a few seconds for all screens to appear.
- If the **Windows Security** screen appears, select the check box and click **Install** to complete the installation correctly.

- i** When the **On-Line Registration** screen is displayed, make your selection and follow the on-screen instructions.

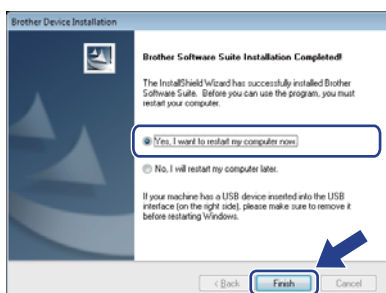

6 Finish and restart

- a** Click **Finish** to restart your computer.





NOTE

If an error message appears during the software installation, do one of the following:

- Windows® XP, Windows Vista® and Windows® 7 users: Run the **Installation Diagnostics** located in  (**Start**) > **All Programs** > **Brother** > **ADS-XXXXX** (where XXXXX is your model name).
- Windows® 8 users: To run the **Installation Diagnostics**, double-click  (**Brother Utilities**) on the desktop, and then click the drop-down list and select your model name (if not already selected). Click **Tools** in the left navigation bar.

- b** The following screens will appear:
- When the **Software Update Setting** screen appears, choose the software update setting you want and click **OK**.
 - When the Brother Product Research and Support Program starts up, follow the on-screen instructions.

NOTE

- Internet access is required for the software update and the Brother Product Research and Support Program.
- When you install MFL-Pro Suite, Brother Help will also be installed automatically. Launch Brother Help  by clicking  in the system tray. Click  to access the Brother Solutions Center.

Finish

The installation is now complete and it is time to do a test scan. See **Test Scan (scan to PDF)** on page 18.

To install optional applications:

Now go to

Page 16



- g** Choose your machine from the list, and then click **Next**.

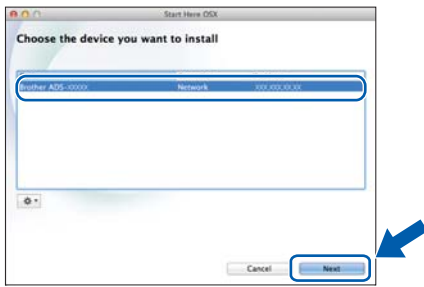

NOTE

If your wireless settings fail, the **Wireless Device Setup Wizard** screen appears. Follow the on-screen instructions to complete the wireless configuration.



- h** The installation of the Brother drivers will automatically start. Please wait for the software to install.

NOTE

- (ADS-1000W)
You can find your machine's MAC Address (Ethernet Address) in **Network Status** from the **Network** tab, and IP address in **TCP/IP (Wireless)** in **Wireless** from the Network tab, in Web Based Management. See *How to Configure the Machine Settings Using Web Based Management (Web Browser)* in the *Network User's Guide*.

(ADS-1500W)

You can display your machine's MAC Address (Ethernet Address) and IP Address using the machine's LCD. To find the MAC Address, press (Settings) > Network > WLAN > MAC Address. To find the IP Address, press (Settings) > Network > WLAN > TCP/IP > IP Address.

- If the **Setup Network "Scan to" name** screen appears, type a name for your Macintosh (up to 15 characters), and then click **Next**.



The name you type will appear in the **Destination** drop-down list in **Scan to Network Device** from the **Scan** tab in Web Based Management (ADS-1000W only)(see *Save Scanned Documents on Your Computer* in the *User's Guide*) or on the LCD of the machine (ADS-1500W only) when you choose a scan option. For more information, see *Scan from the Control Panel of the Machine* in the *User's Guide*.

Finish

The installation is now complete and it is time to do a test scan. See *Test Scan (scan to PDF)* on page 18.

To install optional applications:

Now go to



5 One-push setup using WPS or AOSS™ (mobile devices)

(ADS-1000W)

- a Confirm that your wireless access point/router has the WPS or AOSS™ symbol as shown below.



- b Place the Brother machine within range of your WPS or AOSS™ access point/router. The range may differ depending on your environment. Refer to the instructions provided with your access point/router.

- c Press the WPS or AOSS™ button on your wireless access point/router (for more information, see the instructions provided with your wireless access point/router).

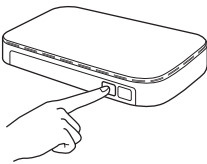

- d Using a small, pointed object, press the AOSS/WPS button on the back of the machine for less than two seconds.

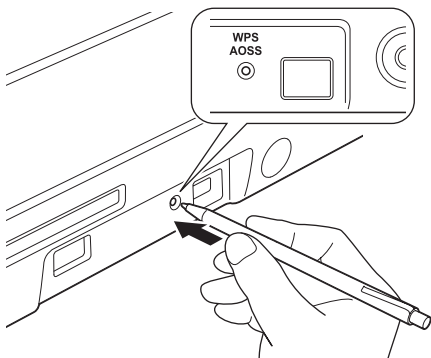

NOTE

- If you do not press the AOSS/WPS button on the back of the machine soon after pressing the WPS or AOSS™ button on your wireless access point/router, the connection may fail.
- If your wireless access point/router supports WPS and you want to configure your machine using the PIN (Personal Identification Number) Method, see *Configuration using the PIN Method of WPS (Wi-Fi Protected Setup)* in the *Network User's Guide*.

- e This feature will automatically detect which mode (WPS or AOSS™) your wireless access point/router uses and try to connect to your wireless network.

- f If your wireless device is connected successfully, the Wi-Fi light  on the Control Panel will light up. If the connection failed, the LEDs blink to indicate an error status. Make a note of the error status, see *Troubleshooting* on page 13, and then correct the error.

OK! **Wireless setup is now complete.**
The Wi-Fi light  on the Control Panel lights up, indicating that the machine's Network I/F is set to WLAN.

NOTE

- Connect your mobile device to a wireless access point/router using a Wi-Fi connection.
- Download and install Brother iPrint&Scan (Android™/iOS/Windows® Phone) from your mobile device's application download site.
- To download the User's Guide for the application you are using (Brother iPrint&Scan), visit the Brother Solutions Center at <http://solutions.brother.com/> and click Manuals on your model's page.



(ADS-1500W)

- a** Confirm that your wireless access point/router has the WPS or AOSS™ symbol as shown below.



- b** Place the Brother machine within range of your WPS or AOSS™ access point/router. The range may differ depending on your environment. Refer to the instructions provided with your access point/router.

- c** On the machine's Control Panel, press  (Settings) > Network > WLAN > WPS/AOSS.

When **Enable WLAN?** is displayed, press **Yes** to accept.

NOTE

- If you do not start WPS/AOSS from the machine's Control Panel soon after pressing the WPS or AOSS™ button on your wireless access point/router, the connection may fail.
- If your wireless access point/router supports WPS and you want to configure your machine using the PIN (Personal Identification Number) Method, see *Configuration using the PIN Method of WPS (Wi-Fi Protected Setup)* in the *Network User's Guide*.

- d** When the LCD instructs you to start WPS or AOSS™, press the WPS or AOSS™ button on your wireless access point/router (for more information, see the instructions provided with your wireless access point/router).

Press **OK** on your machine.

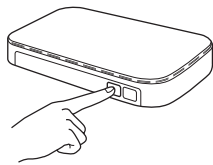

- e** This feature will automatically detect which mode (WPS or AOSS™) your wireless access point/router uses and try to connect to your wireless network.

f

If your wireless device is connected successfully, the LCD will display the message **Connected** until you press **OK**. If the connection failed, the LCD will display an error code. Make a note of the error code, see *Troubleshooting* on page 13, and then correct the error.



Wireless setup is now complete.

The **Wi-Fi light**  on the **Control Panel** lights up, indicating that the machine's **Network I/F is set to WLAN**.

NOTE

- Connect your mobile device to a wireless access point/router using a Wi-Fi connection.
- Download and install Brother iPrint&Scan (Android™/iOS/Windows® Phone) from your mobile device's application download site.
- To download the User's Guide for the application you are using (Brother iPrint&Scan), visit the Brother Solutions Center at <http://solutions.brother.com/> and click **Manuals** on your model's page.



Troubleshooting

If you need assistance during setup and want to contact Brother Customer Service, make sure you have your SSID (Network Name) and Network Key ready. We cannot assist you in locating this information.

How can I find the wireless security information (SSID and Network Key*)

- 1) Check documentation provided with your wireless access point/router.
- 2) The default SSID could be the manufacturer's name or the model name.
- 3) If you do not know the security information, please consult the router manufacturer, your system administrator, or your Internet provider.

- * The Network Key may also be described as the Password, Security Key, or Encryption Key.
- * If the WLAN access point/router is not broadcasting the SSID, the SSID will not automatically be detected. You must manually enter the SSID name. See *Configuring your machine when the SSID is not broadcasting* in the *Network User's Guide*.

Error Status/Error Codes

If the LED indicators (on the ADS-1000W) or the LCD (on the ADS-1500W) indicate an error, locate the error status or code in the tables that follow and use the recommended solution to correct the error.

	The LED is on.
	The LED is blinking.

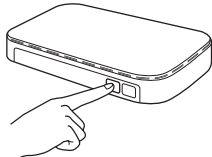
ADS-1000W Error Status	Recommended Solutions
	<p>The machine cannot detect a wireless access point/router that has WPS or AOSS™ enabled.</p> <p>To configure your wireless settings using WPS or AOSS™, you must configure both your machine and the wireless access point/router. Confirm that your wireless access point/router supports WPS or AOSS™, and start from step 5 on page 11 again.</p> <p>If you do not know how to operate your wireless access point/router using WPS or AOSS™, see the documentation provided with your wireless access point/router, ask the manufacturer of your wireless access point/router, or ask your system administrator.</p> 
	<p>Two or more wireless access points that have WPS or AOSS™, enabled are detected.</p> <p>Confirm that only one wireless access point/router within range has the WPS or AOSS™ method active and try again.</p> <p>Try starting from step 5 on page 11 again after a few minutes in order to avoid interference from other access points.</p>



ADS-1500W Error Code	Recommended Solutions												
TS-01	<p>The wireless setting is not activated.</p> <p>Turn the wireless setting to ON:</p> <ol style="list-style-type: none"> 1. On your machine, press  (Settings) > Network > WLAN > Setup Wizard. 2. When <code>Enable WLAN?</code> is displayed, press <code>Yes</code>. This will start the wireless setup wizard. 												
TS-02	<p>The wireless access point/router cannot be detected.</p> <ol style="list-style-type: none"> 1. Check the following: <ul style="list-style-type: none"> - Make sure that the wireless access point/router is powered on. - Move your machine to an obstruction-free area, or closer to the wireless access point/router. - Temporarily place your machine within about 3.3 feet (one meter) from the wireless access point when you are configuring the wireless settings. - If your wireless access point/router is using MAC address filtering, confirm the MAC address of the Brother machine is allowed in the filter. 2. If you manually entered the SSID and security information (SSID/authentication method/encryption method/Network Key), the information may be incorrect. <p>Confirm the SSID and security information and re-enter the correct information as necessary. See <i>How can I find the wireless security information (SSID and Network Key*)</i> on page 13.</p>												
TS-03	<p>The wireless network and security setting you entered may be incorrect.</p> <p>Confirm the wireless network settings. See <i>How can I find the wireless security information (SSID and Network Key*)</i> on page 13.</p> <p>Confirm that the entered or selected SSID/authentication method/encryption method/UserID/Userpass are correct.</p>												
TS-04	<p>The Authentication/Encryption methods used by the selected wireless access point/router are not supported by your machine.</p> <p>For infrastructure mode, change the authentication and encryption methods of the wireless access point/router. Your machine supports the following authentication methods:</p> <table border="1" data-bbox="440 1487 1198 1751"> <thead> <tr> <th>Authentication Method</th> <th>Encryption Method</th> </tr> </thead> <tbody> <tr> <td rowspan="2">WPA-Personal</td> <td>TKIP</td> </tr> <tr> <td>AES</td> </tr> <tr> <td>WPA2-Personal</td> <td>AES</td> </tr> <tr> <td rowspan="2">Open</td> <td>WEP</td> </tr> <tr> <td>None (without encryption)</td> </tr> <tr> <td>Shared key</td> <td>WEP</td> </tr> </tbody> </table> <p>If your problem is not solved, the SSID or network settings you entered may be incorrect. Reconfirm the wireless network settings. See <i>How can I find the wireless security information (SSID and Network Key*)</i> on page 13.</p> <p>For ad-hoc mode, change the authentication and encryption methods of your computer for the wireless setting. Your machine supports Open authentication method only, with optional WEP encryption.</p>	Authentication Method	Encryption Method	WPA-Personal	TKIP	AES	WPA2-Personal	AES	Open	WEP	None (without encryption)	Shared key	WEP
Authentication Method	Encryption Method												
WPA-Personal	TKIP												
	AES												
WPA2-Personal	AES												
Open	WEP												
	None (without encryption)												
Shared key	WEP												

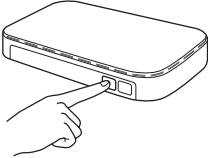

ADS-1500W Error Code	Recommended Solutions
TS-05	<p>The security information (SSID/Network Key) is incorrect.</p> <p>Confirm the SSID and security information (Network Key). See <i>How can I find the wireless security information (SSID and Network Key*)</i> on page 13.</p> <p>If your router uses WEP encryption, enter the key used as the first WEP key. Your Brother machine supports the use of the first WEP key only.</p>
TS-06	<p>The wireless security information (Authentication method/Encryption method/Network Key) is incorrect.</p> <p>Confirm the wireless security information (Authentication method/Encryption method/Network Key) using the Authentication Method table in error TS-04. See <i>How can I find the wireless security information (SSID and Network Key*)</i> on page 13.</p> <p>If your router uses WEP encryption, enter the key used as the first WEP key. Your Brother machine supports the use of the first WEP key only.</p>
TS-07	<p>The machine cannot detect a wireless access point/router that has WPS or AOSS™ enabled.</p> <p>To configure your wireless settings using WPS or AOSS™, you must operate both your machine and the wireless access point/router. Confirm that your wireless access point/router supports WPS or AOSS™, and try starting step 5 on page 11 again.</p> <p>If you do not know how to operate your wireless access point/router using WPS or AOSS™, see the documentation provided with your wireless access point/router, ask the manufacturer of your wireless access point/router, or ask your network administrator.</p> 
TS-08	<p>Two or more wireless access points that have WPS or AOSS™, enabled are detected.</p> <p>Confirm that only one wireless access point/router within range has the WPS or AOSS™ method active and try again.</p> <p>To avoid interference from other access points, after a few minutes, try again starting from step 5 on page 11.</p>
TS-20	<p>The machine is still trying to connect to your wireless network. Please wait a few minutes, and then check the WLAN status.</p>

Install Optional Applications

1 Install optional applications (Windows® users)

BR-Receipts (USA only)

Brother's BR-Receipts application processes receipts by taking information from your scanned images and categorizing it. You can generate reports to view and track categorized expenses.

Nuance PDF Converter Professional 8 (ADS-1500W only)

Nuance PDF Converter Professional 8 offers a variety of features for handling PDF files. It can unlock and open PDF files for viewing, editing, annotation and re-assembly.

Enter the Nuance serial number that is shown on the MFL-Pro Suite DVD-ROM sleeve when installing Nuance PDF Converter Professional 8.

a Reinsert the DVD-ROM or double-clicking the **start.exe** program. If the model name screen appears, choose your machine. If the language screen appears, choose your language.

b The DVD-ROM **Top Menu** will appear. Click **Additional Applications**.

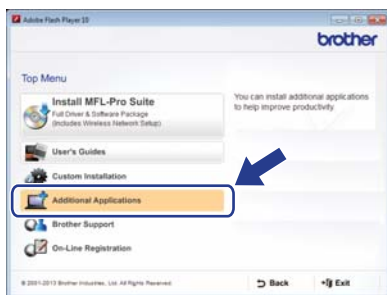





c Click the button for the application you want to install. (These applications available may differ depending on your country.)



d When installation is complete, click **Back** to go back to the **Additional Applications** screen and install other applications.

To exit, click **Exit**.

NOTE

- To start BR-Receipts, do one of the following:
 - Windows® XP, Windows Vista® and Windows® 7 users: Click  (**Start**) > **All Programs** > **Brother** > **BR-Receipts**.
 - Windows® 8 users: Double-click  (**Brother Utilities**) on the desktop, and then click  (**BR-Receipts**).
- To start Nuance PDF Converter Professional 8, do one of the following:
 - Windows® XP, Windows Vista® and Windows® 7 users: Click  (**Start**) > **All Programs** > **Nuance PDF Converter Professional 8** > **PDF Converter Professional**.
 - Windows® 8 users: Move your mouse to the lower right corner of your desktop. When the menu bar appears, click **Start** and then click  (**PDF Converter Professional**).

Finish

The installation is now complete.

Install Optional Applications

1 Install optional applications (Macintosh users)

BR-Receipts (USA only)

Brother's BR-Receipts application processes receipts by taking information from your scanned images and categorizing it. You can generate reports to view and track categorized expenses.

Presto! PageManager

Presto! PageManager adds Optical Character Recognition (OCR) capability to Brother ControlCenter2. OCR allows you to scan a document and convert its contents to text, so that you can edit the text using the word processing application of your choice. You can scan, share and organize photos and documents using Presto! PageManager.

- a** Double-click the **Brother Support** icon to install. The **Brother Support** window will appear.



- b** Click the button for the application you want to install. (These applications available may differ depending on your country.)

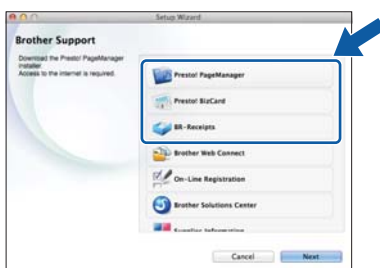

Finish

The installation is now complete.

1 Load your document

- a** Lift the Document Support Arms ①.

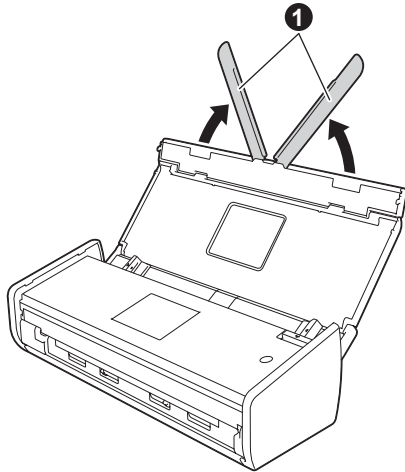

- b** Place your document, face down, top edge first in the document feeder between the Guides until you feel it touch the inside of the machine gently.

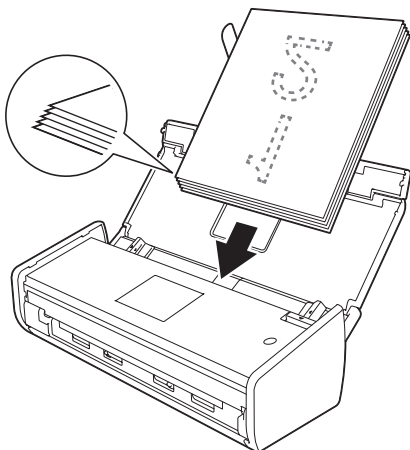

NOTE

When you load multiple documents, position the documents so that the leading edges are aligned at a slight angle in the feed direction.

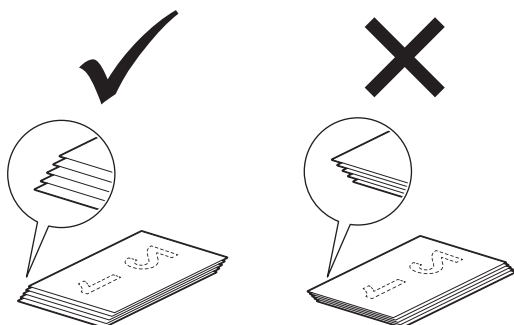

For Windows® users:

Now go to

Step 2 on page 18

For Macintosh users:

Now go to



Step 2 on page 19

2 Scan using ControlCenter4 (Windows®)

- a** Click the  (ControlCenter4) icon in the system tray, and then select **Open** from the menu.

NOTE

If the  icon is not displayed in the system tray, do one of the following:

- Windows® XP, Windows Vista® and Windows® 7 users: Click  (**Start**) > **All Programs** > **Brother** > **ADS-XXXXX** > **ControlCenter4** (where XXXXX is your model name).
- Windows® 8 users: Double-click  (**Brother Utilities**) on the desktop, and then click  (**ControlCenter4**).

- b** Select **Home Mode** in the mode dialog box. The **ControlCenter4** window appears.

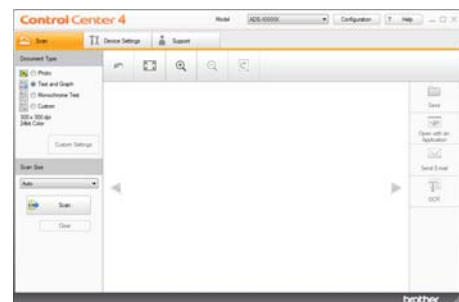

- c** Click  (**Scan**). The machine starts to feed and scan your document.

- d** Click  (**Save**). The **Save** dialog box appears.

Test Scan (scan to PDF)

- e Click **OK**. The scanned data will be saved in PDF format.

Finish

The test scan is now complete.

NOTE

(ADS-1000W only)

If you set up the machine using a Wireless Network connection and want to start scanning using Scan to FTP, Scan to PC (Network Connect) or WS Scan, see *Scan from the Control Panel of the Machine* in the *User's Guide* to configure the scan settings from the machine's Control Panel.



How to open a PDF file in Adobe Reader® (Windows® 8)

- a Move your mouse to the lower right corner of your desktop. When the menu bar appears, click **Settings**, and then click **Control Panel**.
- b Click **Programs**, click **Default Programs**, and then click **Associate a file type or protocol with a program**.
- c Select **.pdf**, and then click the **Change program...** button.
- d Click **Adobe Reader**. The icon next to **.pdf** changes to the 'Adobe Reader' icon.
Adobe® Reader® is now the default application for reading .pdf files until you change this file association.

2 Scan using ControlCenter2 (Macintosh)

- a Click the  (ControlCenter2) icon in the Dock. The **ControlCenter2** window appears.

NOTE

If the  icon is not displayed in the Dock, click **Go** from the **Finder** bar, **Applications**, **Brother**, and then double-click the  icon. The  (ControlCenter2) icon will appear in the Dock.

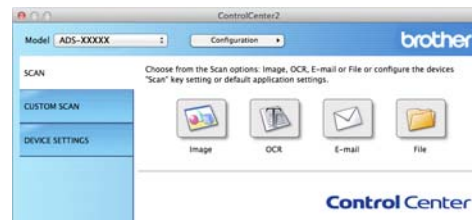

- b Click  (**File**).
- c Click **Start Scanning**. The machine starts to feed and scan your document.
The scanned data is saved in PDF format.

Finish

The test scan is now complete.

NOTE

(ADS-1000W only)

If you set up the machine using a Wireless Network connection and want to start scanning using Scan to FTP, Scan to PC (Network Connect) or WS Scan, see *Scan from the Control Panel of the Machine* in the *User's Guide* to configure the scan settings from the Control Panel.

Symbols and conventions used in the documentation

The following symbols and conventions are used throughout the documentation.

WARNING

WARNING indicates a potentially hazardous situation which, if not avoided, could result in death or serious injuries.

CAUTION

CAUTION indicates a potentially hazardous situation which, if not avoided, may result in minor or moderate injuries.

IMPORTANT

IMPORTANT indicates a potentially hazardous situation which, if not avoided, may result in damage to property or loss of product functionality.

NOTE

Notes tell you how you should respond to a situation that may arise or give tips about how the operation works with other features.



Prohibition icons indicate actions that must not be performed.



This icon indicates that flammable sprays may not be used.



This icon indicates that organic solvents such as alcohol and liquids may not be used.



Electrical Hazard icons alert you to possible electrical shock.



Fire Hazard icons alert you to the possibility of fire.



Unplug icons indicate that you should unplug the machine.

Bold

Bold typeface identifies specific keys on the machine's control panel or on the computer screen.

Italics

Italicized typeface emphasizes an important point or refers you to a related topic.

(ADS-1500W
only)

Text in Courier New font identifies messages on the LCD of the machine.

`Courier New`

Follow all warnings and instructions marked on the machine.

NOTE

The illustrations in this guide show the ADS-1500W.

Compilation and Publication

Under the supervision of Brother Industries, Ltd., this manual has been compiled and published, covering the latest product descriptions and specifications.

The contents of this manual and the specifications of this product are subject to change without notice.

Brother reserves the right to make changes without notice in the specifications and materials contained herein and shall not be responsible for any damages (including consequential) caused by reliance on the materials presented, including but not limited to typographical and other errors relating to the publication.

Choosing a location

Put your machine and AC adapter (hereinafter collectively referred to as “the unit”) on a flat, level, stable surface that is free of vibration and shocks, such as a desk. Choose a location where the temperature remains between 41°F and 95°F (5°C and 35°C) and the humidity is between 20% to 80% (without condensation).

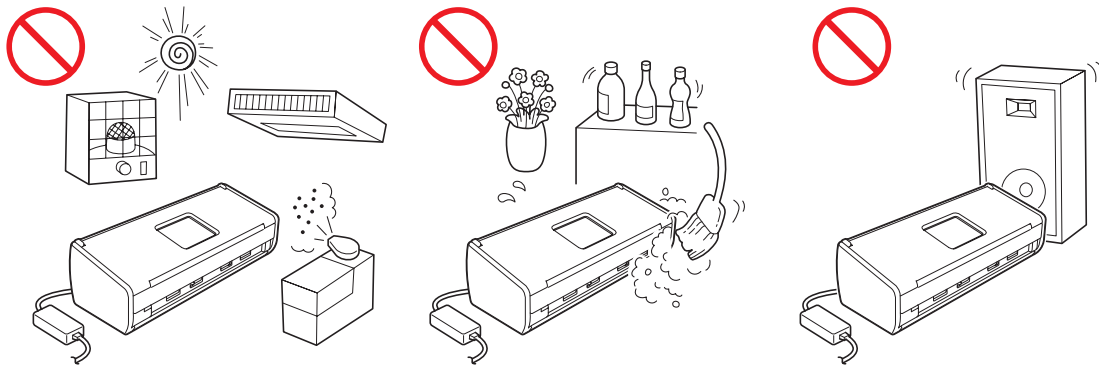

WARNING



DO NOT expose the unit to direct sunlight, excessive heat, open flames, corrosive gasses, moisture or dust.

DO NOT place the unit on a carpet or rug, as this will expose it to dust. Doing so may create a risk of an electrical short or fire. It may also damage the unit and/or render it inoperable.



DO NOT place the unit near heaters, air conditioners, electric fans, refrigerators, radiators, or water. Doing so may create the risk of a short circuit or fire should water come into contact with the unit (including condensation from heating, air conditioning, and/or ventilation equipment that may be sufficient to create a short circuit or fire).



DO NOT place the unit near chemicals or in a place where chemicals could be spilled on it. Should chemicals come into contact with the unit, there may be a risk of fire or electric shock. In particular, organic solvents or liquids such as benzene, paint thinner, polish remover, or deodorizer may melt or dissolve the plastic cover and/or cables, resulting in a risk of fire or electric shock. These or other chemicals may also cause the unit to malfunction or become discolored.



The product should be placed so as not to come into contact with any wall or other device. Otherwise, it could create a risk of overheating and/or fire.

Instead:

- Place the unit on a solid surface, never on a bed, sofa, rug, or other similar soft surface.
- Do not place the unit in a “built-in” installation unless adequate ventilation is provided.

CAUTION

Avoid placing the unit in a high-traffic area. If you must place it in a high-traffic area, ensure that the unit is in a safe location where it cannot be accidentally knocked-over, which could cause injury to you and serious damage to the unit.

Ensure that cables and cords leading to the unit are secured so as not to pose a tripping hazard.

DO NOT place the unit on an unstable or tilted cart, stand, table or on any tilted/slanted surface. The machine is heavy and may fall, causing injury to you and serious damage to the unit.

Make sure that no part of the unit protrudes from the desk or stand where the unit is located. Make sure that the unit is located on a flat, level, and stable surface free from vibration. Failure to observe these precautions could cause the unit to fall, causing injury to you and serious damage to the unit.

IMPORTANT

- DO NOT place your machine next to sources of interference, such as speakers or the base units of non-Brother cordless telephones. Doing so may interfere with the operation of the machine’s electronic components.
- DO NOT connect the unit to an AC power outlet controlled by wall switches or automatic timers. Disruption of power can delete information from the machine’s memory, and repeated cycling of the power can damage the unit.

To use the unit safely

WARNING

ELECTRICAL HAZARDS

Failure to follow the warnings in this section may create the risk of an electrical shock. In addition, you could create an electrical short, which may create the risk of a fire.



There are high-voltage electrodes inside the unit. Before you access the inside of the machine, including for routine maintenance such as cleaning, make sure you have unplugged the power cord from the AC power outlet.

DO NOT push objects of any kind into the unit through slots or openings in the cabinet, as they may touch dangerous voltage points or short out parts.

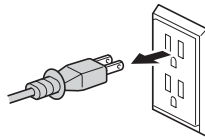

DO NOT continue using the unit if it has been dropped or the cabinet has been damaged. Instead, unplug the unit from the power outlet and contact Brother Authorized Service Personnel.



The unit should be connected to an AC power source within the range indicated on *Specifications* in the *User's Guide*. **DO NOT** connect it to a DC power source or inverter. Doing this might cause an electrical shock or a risk of fire. If you are not sure what kind of power source you have, contact a qualified electrician.



If water, other liquids, or metal objects get inside the unit, immediately unplug the unit from the AC power outlet and contact Brother Authorized Service Personnel.



Power Cord Safety:

- Use only the power cord supplied with this product.
- **DO NOT** allow anything to rest on the power cord.
- **DO NOT** place the unit where people can walk on the cord.
- **DO NOT** place the unit in a position where the cord is stretched or strain is otherwise put on the cord, as it may become worn or frayed.
- **DO NOT** use the unit or handle the cord if the cord has become worn or frayed. If unplugging the unit, **DO NOT** touch the damaged/frayed part.
- Brother strongly recommends that you **DO NOT** use any type of extension cord.

AC Adapter Safety



Only use the supplied AC adapter with the unit. Only plug the AC adapter into a power outlet with voltage that is within the range indicated on *Specifications* in the *User's Guide*. Failure to do so may result in injury to yourself or others, or damage to the machine or other property. Brother does not assume any responsibility for any damage resulting from using an AC adapter other than the one specified.



DO NOT use a damaged AC adapter.



DO NOT place heavy objects on, damage, or modify the AC adapter.



DO NOT forcibly bend the cord of the AC adapter.



DO NOT forcibly pull the cord of the AC adapter.



DO NOT drop, hit, or otherwise damage the AC adapter.



DO NOT touch the unit during a thunderstorm when the AC adapter is plugged in. There may be a remote risk of electric shock from lightning when the machine is used during a thunderstorm.



When disconnecting the AC adapter from the machine or from the power outlet, always hold the connector, not the cable, and pull firmly. Failure to do so may result in exposed or broken power cord wires and/or create a risk of fire, or electric shock.



Make sure that one end of the power cord is firmly plugged into a standard power outlet and the other end is firmly plugged into the adapter block. Do not use an outlet that is loose. If the power cord is not completely plugged into the power outlet and adapter block, the adapter may become hot and/or catch fire.

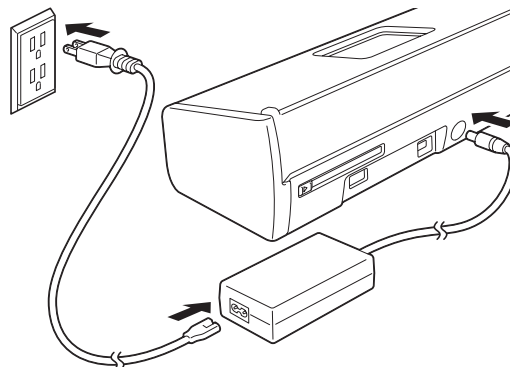

Product Safety Guide



DO NOT exceed the rated input or output of the AC adapter.



DO NOT connect the supplied AC adapter to other products.

This product was packaged in a plastic bag. To avoid suffocation, keep this plastic bag away from babies and children. Do not use the bag in cribs, beds, carriages or play pens. The bag is not a toy.

FIRE HAZARDS

Failure to follow the warnings in this section may create the risk of a fire.



DO NOT use flammable substances, any type of spray or an organic solvent/liquid that contains alcohol or ammonia to clean the inside or outside of the unit. Doing this may cause a risk of fire or electrical shock.



Do not disassemble or modify the unit, otherwise fire or electric shock may result. If the unit requires repair, contact Brother Authorized Service Personnel.



If the unit becomes hot, releases smoke, or generates any strong smells, immediately unplug the unit from the power outlet and call Brother Customer Service.



DO NOT touch the AC adapter or handle the plug with wet hands.

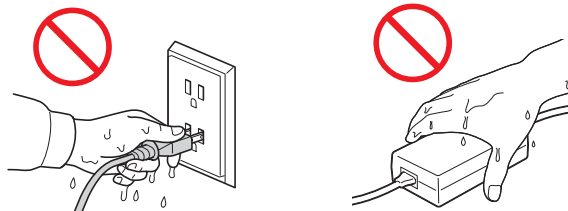

Product Safety Guide

⚠ CAUTION

DO NOT sit or stand on the unit or use it for any purpose beyond its intended purpose.

Wait until pages have exited the machine before picking them out. Otherwise, you could cause injury to your fingers by trapping them in a roller.

DO NOT put your hands on the edge of the machine. Doing this may cause injury to your fingers by pinching them.

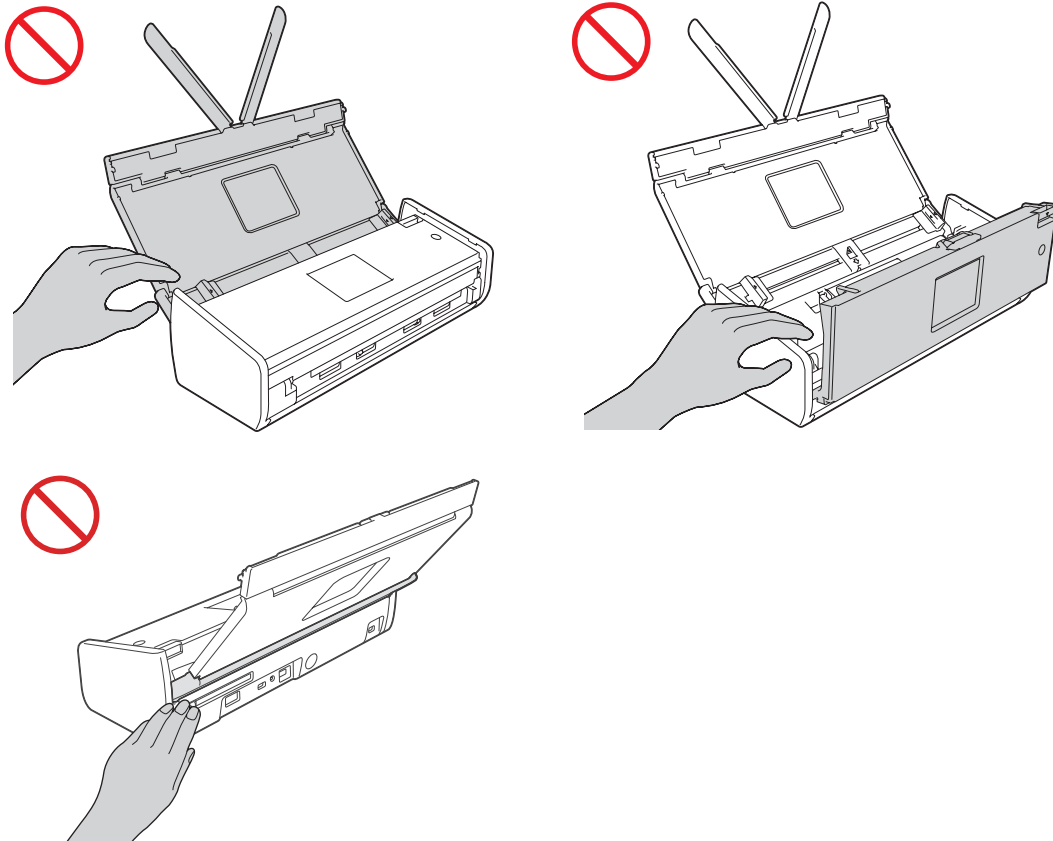

DO NOT touch the shaded area shown below when the top cover is open. Doing this may cause injury to your fingers by pinching them.

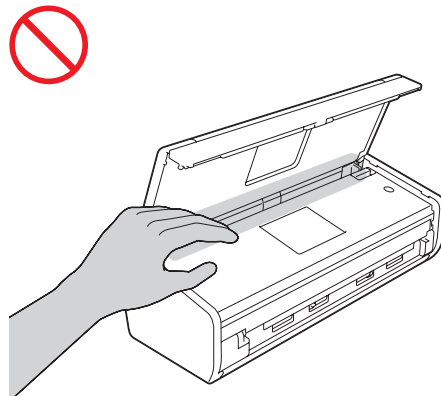

Product Safety Guide

DO NOT carry the machine by holding the top cover. Doing this may cause the machine to slip out of your hands. Only carry the machine by placing your hands under the entire machine.

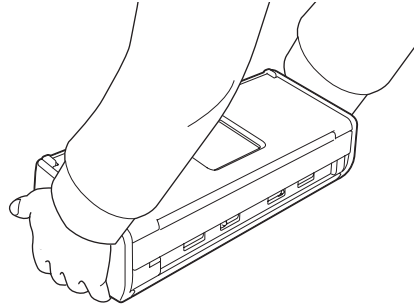
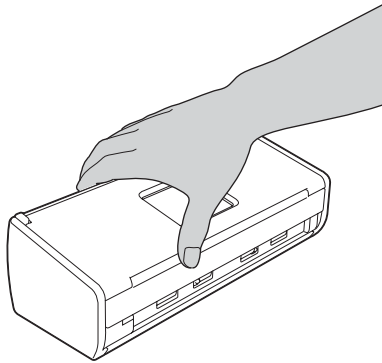

Be careful of the projections on the machine. Otherwise, injury could result.

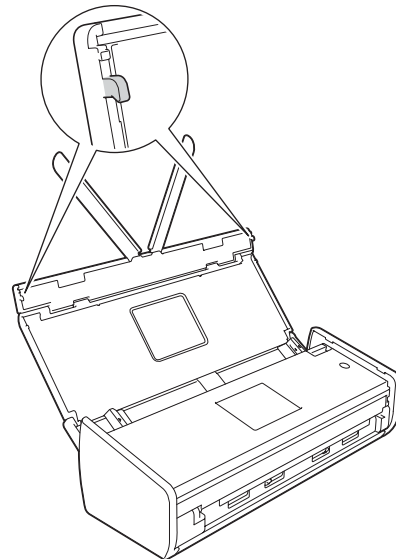
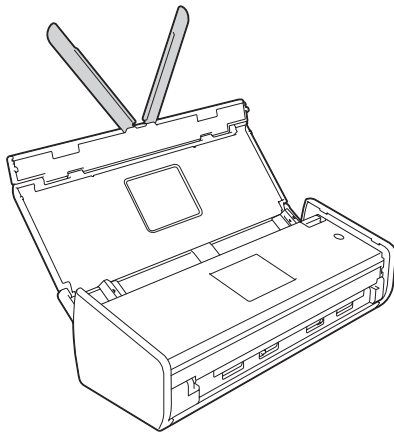

If you do not intend to use the unit for an extended period of time, disconnect the AC adapter from the power outlet.

DO NOT swing the AC adapter around or play with it. Doing so may result in injury to yourself or others.

Use caution when operating the machine to prevent clothing (particularly sleeves, neckties, etc.), hair, or accessories from being drawn into the machine, otherwise injury may result. In the event that an object is drawn into the machine, immediately disconnect the unit from the power source.

IMPORTANT

- Be careful when touching the Separation Pad and its surrounding area in the machine. Otherwise, you could cause serious damage to the machine.

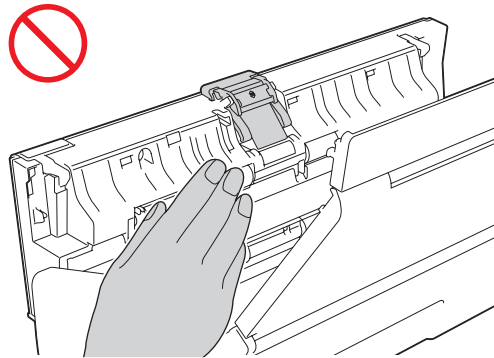

- Disruption of power can wipe out information in the machine's memory.
- DO NOT put objects on top of the unit.
- If the machine does not operate normally when the operating instructions are followed, adjust only those controls that are covered by the operating instructions. Improper adjustment of other controls may result in damage or minor exposure to electromagnetic waves and will often require extensive work by a qualified technician to restore the machine to normal operation.
- A distinct change in the machine's performance may indicate a need for service.
- (ADS-1500W only)
DO NOT touch the Touchscreen immediately after plugging in the power cord or turning on the machine. Doing this may cause an error.

Important safety instructions

DO NOT attempt to service the unit yourself because opening or removing covers may expose you to dangerous voltage points and other risks and may void your warranty. Refer all servicing to a Brother Authorized Service Center. For the location of your nearest Brother Authorized Service Center, please call:

In USA: 1-877-BROTHER (1-877-276-8437)

In Canada: 1-877-BROTHER

Regulation

WARNING

This product must be installed near an AC power outlet that is easily accessible. In case of an emergency, you must unplug the power cord from the AC power outlet to shut off the power completely.

IMPORTANT

- Brother cannot accept any financial or other responsibilities that may be the result of your use of this information, including direct, special or consequential damages. There are no warranties extended or granted by this document.
- This machine has been certified to comply with FCC standards, which are applied to the USA only.

Federal Communications Commission (FCC) Declaration of Conformity (USA only)

Responsible Party: Brother International Corporation
200 Crossing Boulevard
Bridgewater, NJ 08807 USA
TEL: (908) 704-1700

declares, that the products

Product Name: ADS-1000W and ADS-1500W

comply with Part 15 of the FCC Rules. Operation is subject to the following two conditions:

(1) This device may not cause harmful interference, and (2) this device must accept any interference received, including interference that may cause undesired operation.

This equipment has been tested and found to comply with the limits for a Class B digital device, pursuant to Part 15 of the FCC Rules. These limits are designed to provide reasonable protection against harmful interference in a residential installation. This equipment generates, uses, and can radiate radio frequency energy and, if not installed and used in accordance with the instructions, may cause harmful interference to radio communications. However, there is no guarantee that interference will not occur in a particular installation. If this equipment does cause harmful interference to radio or television reception, which can be determined by turning the equipment off and on, the user is encouraged to try to correct the interference by one or more of the following measures:

- Reorient or relocate the receiving antenna.
- Increase the separation between the equipment and receiver.
- Connect the equipment into an outlet on a circuit different from that to which the receiver is connected.
- Consult the dealer or an experienced radio/TV technician for help.
- This transmitter must not be co-located or operated in conjunction with any other antenna or transmitter.

IMPORTANT

- Changes or modifications not expressly approved by Brother Industries, Ltd. could void the user's authority to operate the equipment.
- A specific shielded interface cable should be used to ensure compliance with the limits for a Class B digital device.

Wireless connection (Mexico only)

The operation of this equipment is subject to the following two conditions:

(1) it is possible that this equipment or device may not cause harmful interference, and (2) this equipment or device must accept any interference, including interference that may cause undesired operation.

Industry Canada Compliance Statement (Canada only)

This device complies with Industry Canada licence-exempt RSS standard(s). Operation is subject to the following two conditions: (1) this device may not cause interference, and (2) this device must accept any interference, including interference that may cause undesired operation of the device.

Le present appareil est conforme aux CNR d'Industrie Canada applicables aux appareils radio exempts de licence. L'exploitation est autorisee aux deux conditions suivantes : (1) l'appareil ne doit pas produire de brouillage, et (2) l'utilisateur de l'appareil doit accepter tout brouillage radioelectrique subi, meme si le brouillage est susceptible d'en compromettre le fonctionnement.

For use in the USA or Canada only

These machines are made for use in the USA and Canada only. We cannot recommend using them overseas because the power requirements of your machine may not be compatible with the power available in foreign countries. Using USA or Canada models overseas is at your own risk and may void your warranty.

International ENERGY STAR® Qualification Statement

The purpose of the International ENERGY STAR® Program is to promote the development and popularization of energy-efficient equipment.

As an ENERGY STAR® Partner, Brother Industries, Ltd. has determined that this product meets the ENERGY STAR® specifications for energy efficiency.



Trademarks

The Brother logo is a registered trademark of Brother Industries, Ltd.

Brother is a registered trademark of Brother Industries, Ltd.

Microsoft, Windows, Windows Vista, Windows Server, Outlook and Internet Explorer are either registered trademarks or trademarks of Microsoft Corporation in the United States and/or other countries.

Apple, Macintosh, Mac OS and Safari are trademarks of Apple Inc., registered in the United States and other countries.

Nuance, the Nuance logo, PaperPort and ScanSoft are trademarks or registered trademarks of Nuance Communications, Inc. or its affiliates in the United States and/or other countries.

PowerPC is a registered trademark of IBM in the United States and/or other countries.

AOSS is a trademark of Buffalo Inc.

WPA, WPA2, Wi-Fi Protected Access and Wi-Fi Protected Setup are marks of the Wi-Fi Alliance.

Wi-Fi and Wi-Fi Alliance are registered marks of the Wi-Fi Alliance.

AMD is a trademark of Advanced Micro Devices, Inc.

Linux is the registered trademark of Linus Torvalds in the U.S. and other countries.

Android is a trademark of Google Inc.

ISIS, Captiva and QuickScan are either registered trademarks or trademarks of EMC Corporation in the United States and/or other countries.

Intel is a trademark of Intel Corporation in the U.S. and/or other countries.

Adobe, Reader and Photoshop are either registered trademarks or trademarks of Adobe Systems Incorporated in the United States and/or other countries.

Each company whose software title is mentioned in this manual has a Software License Agreement specific to its proprietary programs.

Any trade names and product names of companies appearing on Brother products, related documents and any other materials are all trademarks or registered trademarks of those respective companies.

Copyright and License

©2013 Brother Industries, Ltd. All rights reserved.

This product includes software developed by the following vendors:

©1983-1998 PACIFIC SOFTWARES, INC.

©2008 Devicescape Software, Inc.

This product includes the "KASAGO TCP/IP" software developed by ZUKEN ELMIC, Inc.

Open Source Licensing Remarks

This product includes open-source software.

To see the open source licensing remarks, please go to the manual download section on your model's home page of Brother Solutions Center at <http://solutions.brother.com/>.

Legal limitations for copying

Observe all copyright laws when using this product.

Color reproductions of certain documents are illegal and may result in either criminal or civil liability. This memorandum is intended to be a guide rather than a complete listing of every possible prohibition. In case of doubt, we suggest that you check with counsel as to any particular questionable documents.

The following documents issued by the United States/Canadian Government or any of its Agencies may not be copied:

- Money
- Bonds or other certificates of indebtedness
- Certificates of Deposit
- Internal Revenue Stamps (canceled or uncanceled)
- Selective Service or draft papers
- Passports
- United States/Canadian Postage Stamps (canceled or uncanceled)
- Food Stamps
- Immigration Papers
- Checks or drafts drawn by Governmental agencies
- Identifying badges or insignias

Copyrighted works cannot be copied. Sections of a copyrighted work can be copied for 'fair use'. Multiple copies would indicate improper use.

Works of art should be considered the equivalent of copyrighted works.

Notice Regarding the Faithful Reproduction of Scanned Documents

After scanning a document, confirm that the accuracy and quality of the corresponding scan data meets your needs by confirming the size of the scan data, the amount of image data captured, image fidelity, color tones, etc.

Always confirm the scan data before destroying the original document.

It is possible that a portion of the scan data may be lost or damaged, therefore, read all instructions carefully and keep the following in mind.

- Depending on the condition of the document, the document may become worn thin, distorted, dirty, or cracked during scanning. In this case, some or all of the scan data may be lost.

Confirm that the document has no wrinkles, bends, or holes.

- If the inside of the machine is dirty, the document may become worn thin, distorted, dirty, or cracked during scanning. In this case, some or all of the scan data may be lost.

Clean the inside of the machine carefully and regularly.

- The following may occur depending on the scan settings, such as document size, scanning resolution, color-related settings, single-side or double-side scanning settings, auto deskew, blank page skip, etc.

- Text may be illegible or unclear if image resolution is too low.
- Scan data of a color document may be captured in black-and-white.
- Only one side of a two-sided document may be captured.
- A portion of the document may not be scanned, or the size may be too small.
- The document may only be scanned up to a certain point, after which scan data will be lost.
- Blank pages may not be deleted, or pages may be deleted unnecessarily.
- Margins may be added to the edges of the scan data.

Refer to the User's Guide for information about how to configure the scan settings.

Product Safety Guide

- Depending on the condition of the document (such as if it has wrinkles, bends, or holes) and consumables, multiple pages of a document may be fed at once, causing some pages to be missing from the scanned data.

Confirm that the document has no wrinkles, bends, or holes.

Replace all consumables periodically.

- When scanning documents that are not within the recommended guidelines, or depending on the condition of the document (such as if it has wrinkles, bends, or holes), consumables, or the paper feeding mechanisms inside the machine, documents may become jammed inside the machine during scanning. In this case, some or all of the scan data may be lost. (Documents may be destroyed as a result of a paper jam.)

Refer to “Acceptable Documents” in the User’s Guide for information about acceptable documents.

- When scanning documents that have been marked with a fluorescent marker, marked areas may not be seen properly in the scan data, or the marker color may not be reproduced properly, depending on the color and density of the marker ink.

You may achieve more desirable results by increasing the scanning resolution. Refer to the User’s Guide for information about resolution settings.

brother®

Visit us on the World Wide Web
<http://www.brother.com/>



www.brotherearth.com