

BAS-311F-0, 311F-L BAS-326F-0

Please read this manual before using the machine.
Please keep this manual within easy reach for quick reference.

PROGRAMMABLE ELECTRONIC PATTERN SEWER

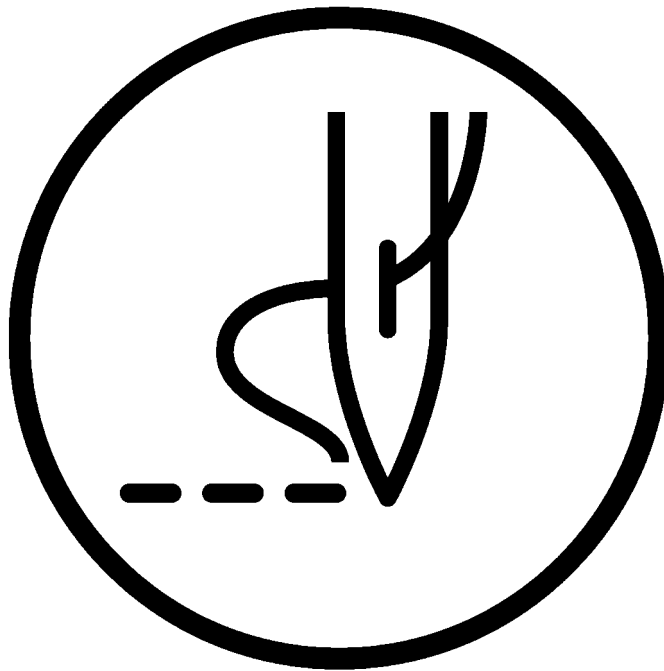

Thank you very much for buying a BROTHER sewing machine. Before using your new machine, please read the safety instructions below and the explanations given in the instruction manual.



With industrial sewing machines, it is normal to carry out work while positioned directly in front of moving parts such as the needle and thread take-up lever, and consequently there is always a danger of injury that can be caused by these parts. Follow the instructions from training personnel and instructors regarding safe and correct operation before operating the machine so that you will know how to use it correctly.

SAFETY INSTRUCTIONS

1 Safety indications and their meanings

This instruction manual and the indications and symbols that are used on the machine itself are provided in order to ensure safe operation of this machine and to prevent accidents and injury to yourself or other people. The meanings of these indications and symbols are given below.

Indications

 DANGER	The instructions which follow this term indicate situations where failure to follow the instructions will almost certainly result in death or severe injury.
 CAUTION	The instructions which follow this term indicate situations where failure to follow the instructions could cause injury when using the machine or physical damage to equipment and surroundings.

Symbols



..... This symbol () indicates something that you should be careful of. The picture inside the triangle indicates the nature of the caution that must be taken.



(For example, the symbol at left means "beware of injury".)
..... This symbol () indicates something that you must not do.



..... This symbol () indicates something that you must do. The picture inside the circle indicates the nature of the thing that must be done.
(For example, the symbol at left means "you must make the ground connection".)

2 Notes on safety

DANGER



Wait at least 5 minutes after turning off the power switch and disconnecting the power cord from the wall outlet before opening the face plate of the control box. Touching areas where high voltages are present can result in severe injury.

CAUTION

Environmental requirements



Use the sewing machine in an area which is free from sources of strong electrical noise such as high-frequency welders. Sources of strong electrical noise may cause problems with correct operation.



Any fluctuations in the power supply voltage should be within $\pm 10\%$ of the rated voltage for the machine. Voltage fluctuations which are greater than this may cause problems with correct operation.



The power supply capacity should be greater than the requirements for the sewing machine's electrical consumption. Insufficient power supply capacity may cause problems with correct operation.



The pneumatic delivery capability should be greater than the requirements for the sewing machine's total air consumption. Insufficient pneumatic delivery capability may cause problems with correct operation.



The ambient temperature should be within the range of 5 to 35 °C during use. Temperatures which are lower or higher than this may cause problems with correct operation.



The relative humidity should be within the range of 45% to 85% during use, and no dew formation should occur in any devices. Excessively dry or humid environments and dew formation may cause problems with correct operation.



Avoid exposure to direct sunlight during use. Exposure to direct sunlight may cause problems with correct operation.



In the event of an electrical storm, turn off the power and disconnect the power cord from the wall outlet. Lightning may cause problems with correct operation.

Installation



Machine installation should only be carried out by a qualified technician.



Contact your Brother dealer or a qualified electrician for any electrical work that may need to be done.



The sewing machine weighs more than 65 kg. (311F-0), 70 kg (311F-L, 326 F-0) The installation should be carried out by two or more people.



Do not connect the power cord until installation is complete, otherwise the machine may operate if the foot switch is depressed by mistake, which could result in injury.



Hold the machine head with both hands by two or more people when tilting it back or returning it to its original position.

Furthermore, after tilting back the machine head, do not push the face plate side or the pulley side from above, as this could cause the machine head to topple over, which may result in personal injury or damage to the machine.



Be sure to connect the ground. If the ground connection is not secure, you run a high risk of receiving a serious electric shock, and problems with correct operation may also occur.



All cords should be secured at least 25 mm away from any moving parts. Furthermore, do not excessively bend the cords or secure them too firmly with staples, otherwise there is the danger that fire or electric shocks could occur.



Install the belt cover and the frame side cover to the machine head and motor.



If using a work table which has casters, the casters should be secured in such a way so that they cannot move.













Be sure to wear protective goggles and gloves when handling the lubricating oil and grease, so that they do not get into your eyes or onto your skin, otherwise inflammation can result.

Furthermore, do not drink the oil or eat the grease under any circumstances, as they can cause vomiting and diarrhoea.



Keep the oil out of the reach of children.

CAUTION











Sewing

- | | | | |
|---|--|---|--|
|  | This sewing machine should only be used by operators who have received the necessary training in safe use beforehand. |  | If using a work table which has casters, the casters should be secured in such a way so that they cannot move. |
|  | The sewing machine should not be used for any applications other than sewing. |  | Attach all safety devices before using the sewing machine. If the machine is used without these devices attached, injury may result. |
|  | Be sure to wear protective goggles when using the machine.
If goggles are not worn, there is the danger that if a needle breaks, parts of the broken needle may enter your eyes and injury may result. |  | Do not touch any of the moving parts or press any objects against the machine while sewing, as this may result in personal injury or damage to the machine. |
|  | Set the needle to the needle up stop position before turning off the power.
If this is not done, the wiper may strike the needle, which might cause the needle to break. |  | If an error occurs in machine operation, or if abnormal noises or smells are noticed, immediately turn off the power switch. Then contact your nearest Brother dealer or a qualified technician. |
|  | Turn off the power switch at the following times, otherwise the machine may operate if the foot switch is depressed by mistake, which could result in injury. <ul style="list-style-type: none">* When replacing bobbin* When not using the machine and when leaving the machine unattended |  | If the machine develops a problem, contact your nearest Brother dealer or a qualified technician. |

Cleaning

- | | | | |
|---|---|---|--|
|  | Turn off the power switch before carrying out cleaning, otherwise the machine may operate if the foot switch is depressed by mistake, which could result in injury. |  | Be sure to wear protective goggles and gloves when handling the lubricating oil and grease, so that they do not get into your eyes or onto your skin, otherwise inflammation can result. Furthermore, do not drink the oil or eat the grease under any circumstances, as they can cause vomiting and diarrhoea. Keep the oil out of the reach of children. |
|  | Wait until the motor has cooled down before cleaning the air holes.
The motor may be hot immediately after it has been used, and it may cause burns if touched. | | |

Maintenance and inspection

- | | | | |
|---|---|---|---|
|  | Maintenance and inspection of the sewing machine should only be carried out by a qualified technician. |  | If the power switch and air need to be left on when carrying out some adjustment, be extremely careful to observe all safety precautions. |
|  | Ask your Brother dealer or a qualified electrician to carry out any maintenance and inspection of the electrical system. |  | Hold the machine head with both hands by two or more people when tilting it back or returning it to its original position. |
|  | Turn off the power switch and disconnect the power cord from the wall outlet at the following times, otherwise the machine may operate if the foot switch is depressed by mistake, which could result in injury. <ul style="list-style-type: none">* When carrying out inspection, adjustment and maintenance* When replacing consumable parts such as the rotary hook |  | Furthermore, after tilting back the machine head, do not push the face plate side or the pulley side from above, as this could cause the machine head to topple over, which may result in personal injury or damage to the machine. |
|  | Disconnect the air hoses from the air supply and wait for the needle on the pressure gauge to drop to "0" before carrying out inspection, adjustment and repair of any parts which use the pneumatic equipment. |  | Use only the proper replacement parts as specified by Brother. |
| | |  | If any safety devices have been removed, be absolutely sure to re-install them to their original positions and check that they operate correctly before using the machine. |
| | |  | Any problems in machine operation which result from unauthorized modifications to the machine will not be covered by the warranty. |

3 Warning labels

★ The following warning labels appear on the sewing machine.

Please follow the instructions on the labels at all times when using the machine. If the labels have been removed or are difficult to read, please contact your nearest Brother dealer.

1

	⚠ DANGER	⚠ GEFAHR	⚠ DANGER	⚠ PELIGRO
	Hazardous voltage will cause injury. Turn off main switch and wait 5 minutes before opening this cover.	Hochspannung verletzungsgefahr! Bitte schalten sie den hauptschalter aus und warten sie 5 minuten, bevor sie diese abdeckung öffnen.	Un voltage non adapté provoque des blessures. Eteindre l'interrupteur et attendre 5 minutes avant d'ouvrir le capot	Un voltaje inadecuado puede provocar las heridas. Apagar el interruptor principal y esperar 5 minutos antes de abrir esta cubierta.

2

	⚠ CAUTION
	Moving parts may cause injury. Operate with safety devices. Turn off main switch before changing needle, cleaning etc.

3 High temperature warning display

- Safety devices
- Eye guard
 - Finger guard
 - Thread take-up cover
 - Belt cover
 - Frame side cover, etc.

4 Be sure to connect the ground. If the ground connection is not secure, you run a high risk of receiving a serious electric shock, and problems with correct operation may also occur.

5 Direction of operation

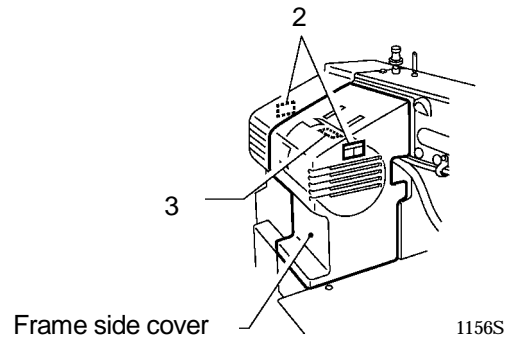
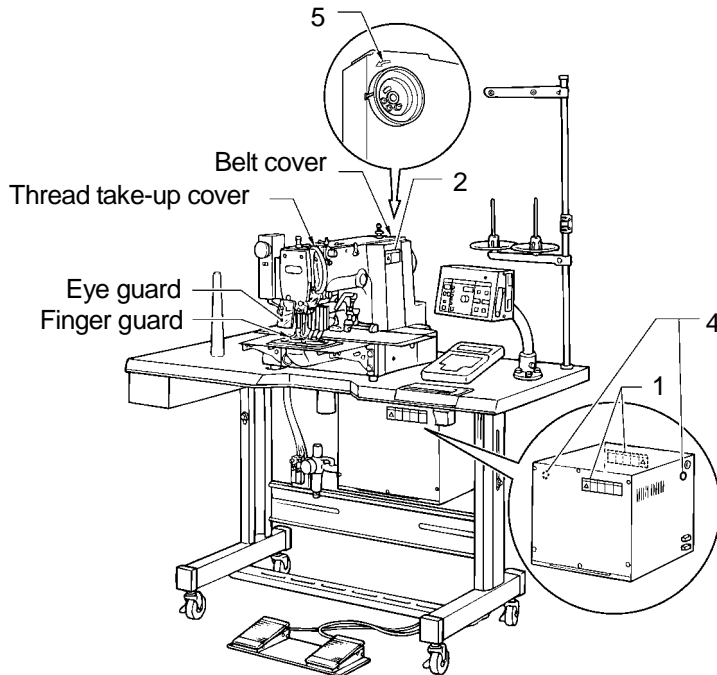

CONTENTS

1. NAME OF MAJOR PARTS	1
2. SPECIFICATIONS	2
3. INSTALLATION	3
3-1. Table processing diagram	4
3-2. Positioning	4
3-3. Installing the control box	5
3-4. Installing the rubber cushions	6
3-5. Installing the oil pan	6
3-6. Installing the cushions	7
3-7. Installing the switching plate	7
3-8. Installing the machine head	8
3-9. Tilting the sewing machine head	9
3-10. Connecting the ground wire	11
3-11. Connecting the cords (Installing the operation panel)	11
3-12. Installing the belt cover	14
3-13. Installing the foot switch	14
3-14. Installing the spool stand	14
3-15. Installing the eye guard	15
3-16. Installing the programmer (option)	16
3-17. Installing the work clamp lifter connecting rod (BAS-311F-0 solenoid type only)	16
3-18. Installing the feed base cover supports (BAS-311F-L, 326F-0)	17
3-19. Installing the X feed base cover (BAS-311F-L, 326F-0)	17
3-20. Connecting the tubes (pneumatic type only)	18
3-20-1. Installing the air unit.....	19
3-20-2. Adjusting the speed controller	19
4. LUBRICATION.....	20
5. CORRECT OPERATION.....	21
5-1. Selecting the needle and thread	21
5-2. Installing the needle	21
5-3. Threading the upper thread	22
5-4. Winding the lower thread	23
5-5. Replacing the bobbin case and threading the thread	24
5-6. Sewing conditions and thread tension	24
5-6-1. Sewing conditions	24
5-6-2. Lower thread tension	25
5-6-3. Upper thread tension	25
5-6-4. Thread take-up spring height	25
5-6-5. Thread take-up spring tension	25
5-6-6. Adjusting arm thread guide R.....	25
6. USING THE OPERATION PANEL.....	26
6-1. Explanation of panel	26
6-2. Using the floppy disk	28
6-3. Using the program R/W (Read/Write) switch	30
6-4. Using the TEST switch (Checking the sewing pattern)	31
6-5. Using the emergency stop switch	32
6-6. Adjusting the sewing SPEED control	33
6-7. Changing the X-SCALE and Y-SCALE settings	33

6-8. Using the bobbin thread counter	34
6-9. Using production counter	35
6-10. Using single split mode	36
6-11. Shifting a stitch pattern	37
7. SEWING	38
7-1. Before starting sewing.....	38
7-2. Sewing operation	38
8. CLEANING AND INSPECTION	40
8-1. Cleaning the rotary hook	40
8-2. Lubrication	40
8-3. Draining the oil	40
8-4. Cleaning the control box air inlet port	41
8-5. Cleaning the air holes of belt cover and frame side cover	41
8-6. Cleaning the eye guard	41
8-7. Checking the needle	41
9. STANDARD ADJUSTMENTS	42
9-1. Adjusting the needle bar height.....	42
9-2. Adjusting the needle bar lift amount	42
9-3. Adjusting the needle clearance	43
9-4. Adjusting the driver needle guard	43
9-5. Adjusting the shuttle race thread guide	43
9-6. Adjusting the movable knife	44
9-7. Adjusting the presser foot	46
9-8. Changing the presser foot lift	47
9-9. Adjusting the wiper	48
9-10. Adjusting the two-step work clamp lift amount	49
9-10-1. BAS-311F-0 Solenoid type	49
9-10-2. BAS-311F-0, 311F-L Pneumatic type	49
9-10-3. BAS-326F-0	50
9-10-4. Adjusting the air pressure	50
9-11. Adjusting the needle up stop position	51
9-12. Checking the input sensor and DIP switch input	52
9-13. Checking the input voltage	53
9-14. Clearing all memory settings	53
10. DIP SWITCH	54
10-1. Panel DIP switch functions	54
10-2. DIP switches inside the control box	56
11. CHANGING SPECIAL FUNCTIONS AND USING THE MEMORY SWITCHES	58
12. ERROR CODES	63
13. GAUGE PARTS LIST ACCORDING TO SUBCLASSES	66
14. TROUBLESHOOTING	68
15. OPTIONS	72

1. NAME OF MAJOR PARTS

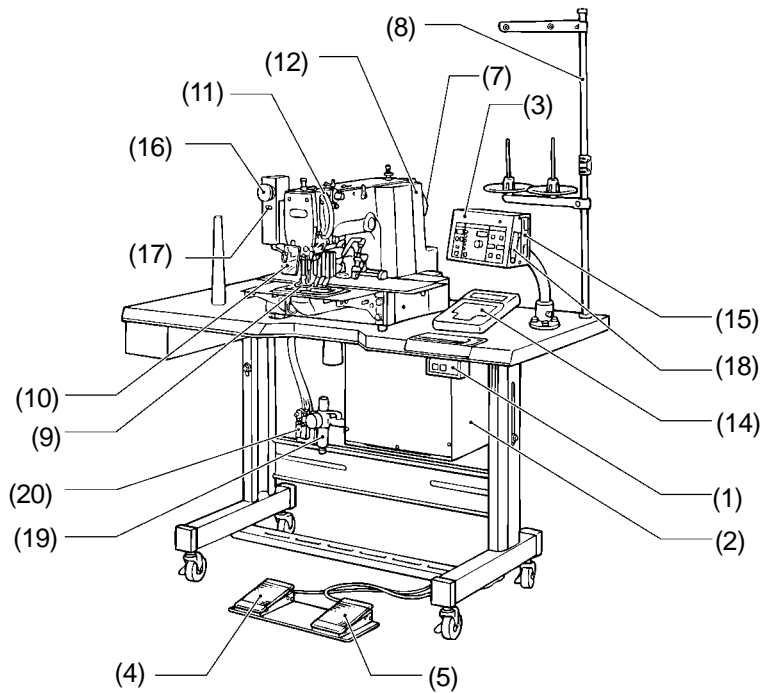

1157S

- (1) Power switch
- (2) Control box
- (3) Operation panel
- (4) Presser lifter pedal
- (5) Starting pedal
- (6) Motor cover
- (7) Pulley
- (8) Spool stand
- (14) Programmer
- (15) Floppy disk drive
- (16) Emergency stop switch
- (17) Thread wiper switch
- (18) Dip switch
- (19) Integrater
- (20) Solenoid valve

Safety devices

- (9) Finger guard
- (10) Eye guard
- (11) Thread take-up cover
- (12) Belt cover
- (13) Frame side cover

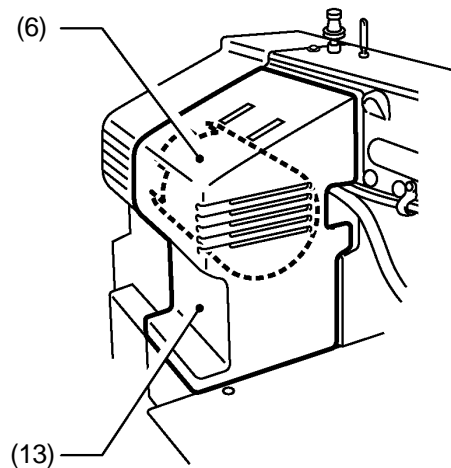

1159S

2. SPECIFICATIONS



1	For Heavy-weight materials
2	For Medium-weight materials
3	For Extra heavy-weight materials
4	For Special uses

S	Work clamp lifter (Solenoid Type)
A	Work clamp lifter (Pneumatic Type)



1	For Heavy-weight materials
4	For Special uses

A	Work clamp lifter (Pneumatic Type)
---	------------------------------------













1	For Heavy-weight materials
2	For Medium-weight materials
4	For Special uses

A	Work clamp lifter (Pneumatic Type)
---	------------------------------------

Stitch formation	Single needle lock stitch
Sewing machine	Lock stitch, pattern tacking sewing machine (with large shuttle hook)
Maximum pattern size	BAS-311F-0: 130 X 60 mm, BAS-311F-L: 220 X 60 mm, BAS-326F-0: 220 X 100 mm
Maximum stitch number	20,000 (one pattern)
Stitch length	0.05 - 12.7 mm
Maximum sewing speed	2,500 rpm (When stitch length is 3 mm or less)
Feed mechanism	Intermittent feed, pulse motor drive
Rotary hook	Shuttle hook (Standard rotary hook is sold separately)
Needle	DP X 5, DP X 17, MR
Data storage method	3.5 floppy disk 2HD/1.44MB, 2DD
Test function	Operation test function provided for use with low speed drive
Safety devices	Automatic stop function for activation in the event of misoperation realized with intermediate stop function and safety circuits
Work clamp height	BAS-311F-0:For solenoid - Max. 17 mm, for pneumatic - Max. 30 mm BAS-311F-L, BAS-326F-0:Max. 30 mm
2-step work clamp	BAS-311F-0:For solenoid - unit work clamp, for pneumatic - separate work clamp BAS-311F-L, BAS-326F-0:Separate work clamp
Work clamp lift stroke	18 mm
Intermittent stroke	0 or 3 (Factory default) - 8 mm
Weights	Machine head BAS-311F-0: 65kg, BAS-311F-L, BAS-326F-0: 70kg Control box: 10 - 20 kg (depending on destination)
Power supply	Single-phase 110V, 220V, 240V, 3-phase 220V, 380V, 400V, 600VA
Motor	Three-phase 400 W induction motor
Air pressure	0.50 MPa 1.8 l / min
Power table	T-shaped for use sitting or standing
Machine dimensions	1,200W X 590 D X 1,120 H mm (Sitting) 1,350 H mm (Standing)Excluding spool stand

3. INSTALLATION

CAUTION

- | | |
|--|---|
| <p> Machine installation should only be carried out by a qualified technician.</p> <p> Contact your Brother dealer or a qualified electrician for any electrical work that may need to be done.</p> <p> The sewing machine head weighs more than 65 kg (311F-0), 70 kg (311F-L, 326F-0). The installation should be carried out by two or more people.</p> <p> Do not connect the power cord until installation is complete, otherwise the machine may operate if the foot switch is depressed by mistake, which could result in injury.</p> <p> Be sure to connect the ground. If the ground connection is not secure, you run the risk of receiving a serious electric shock.</p> <p> Hold the machine head with both hands by two or more people when tilting it back or returning it to its original position. Furthermore, after tilting back the machine head, do not push the face plate side or the pulley side from above, as this could cause the machine head to topple over, which may result in personal injury or damage to the machine.</p> | <p> All cords should be secured at least 25 mm away from any moving parts. Furthermore, do not excessively bend the cable or secure it too firmly staples, otherwise there is the danger that fire or electric shocks could occur.</p> <p> Install the belt cover and the frame side cover to the machine head and motor.</p> <p> If using a work table which has casters, the casters should be secured in such a way so that they cannot move.</p> <p> Be sure to wear protective goggles and gloves when handling the lubricating oil and grease, so that they do not get into your eyes or onto your skin, otherwise inflammation can result. Furthermore, do not drink the oil or eat the grease under any circumstances, as they can cause vomiting and diarrhoea. keep the oil out of the reach of children.</p> |
|--|---|

3. INSTALLATION

3-1. Table processing diagram

* If using a commercially-available table, process it as shown in the illustration below.

Note

The thickness of the table should be at least 40 mm, and it should be strong enough to bear the weight and vibration of the sewing machine.

If the distance A between the insides of the legs is less than 740 mm, move the control box installation position to the left (B=192 mm).

Check that the control box is at least 10 mm away from the leg. If the control box and leg are touching, it could cause the sewing machine to operate incorrectly.

[Standard]

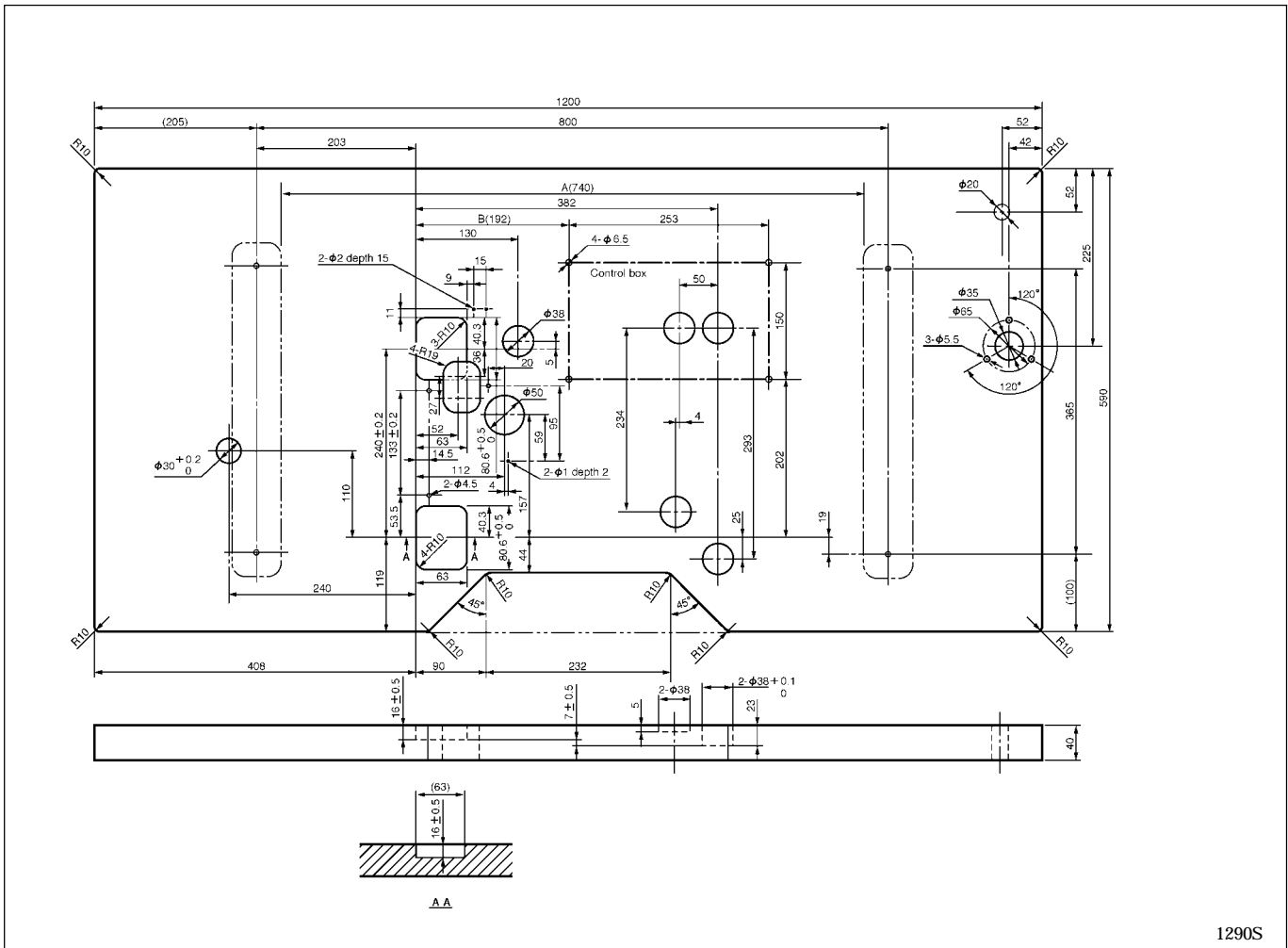

3-2. Positioning

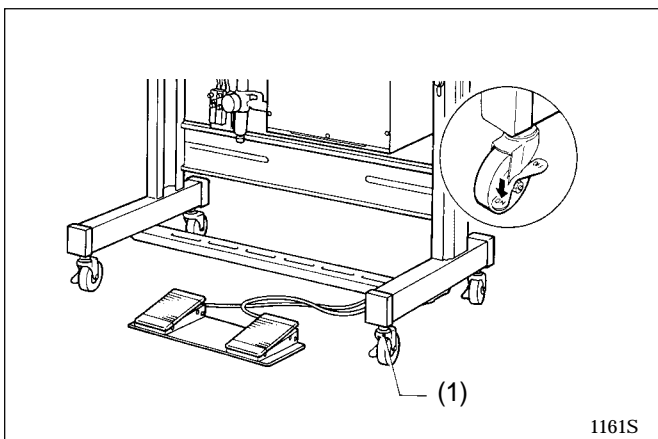

Determine the position for the sewing machine, and then lock the casters (1) so that the sewing machine will not move.

3-3. Installing the control box

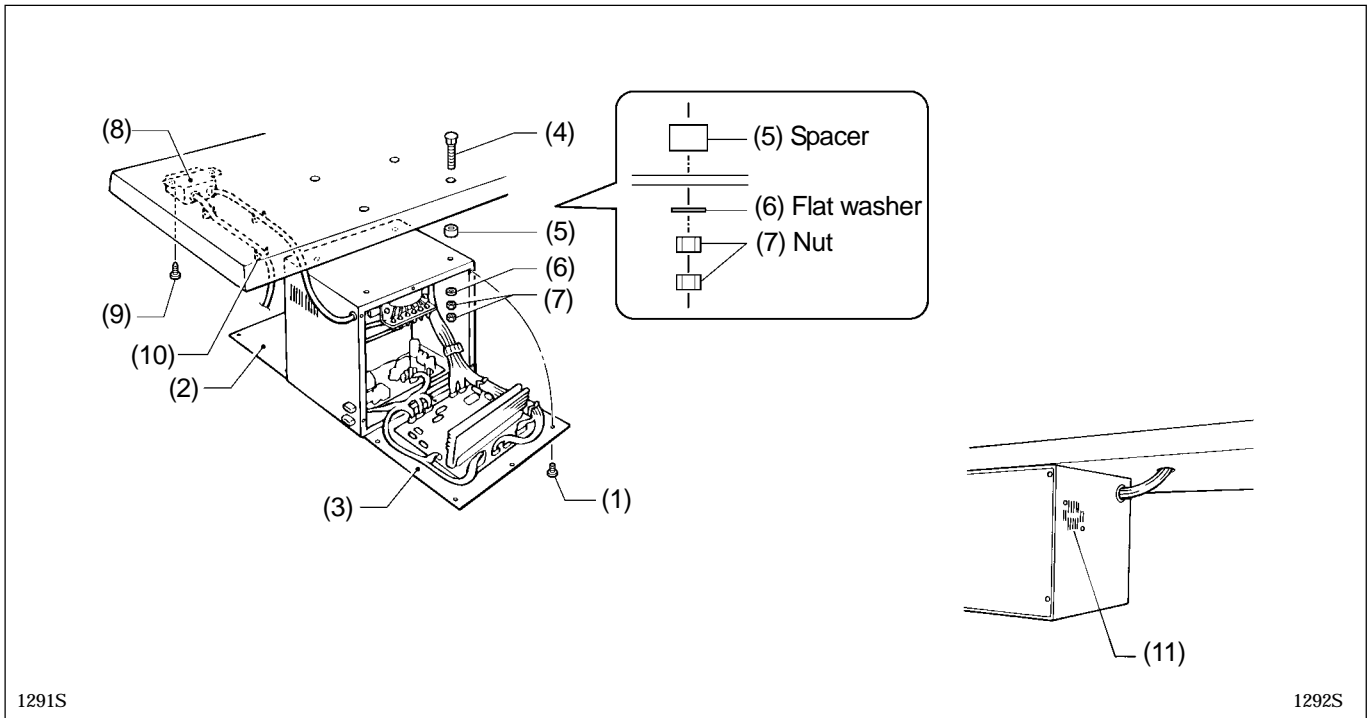

1. Remove the screws (1), and then open the covers (panel mounting assembly (2) and main P.C. board mounting plate (3)).

Caution: When opening the cover, hold it securely so that it does not fall down.

2. Install the control box with the four accessory bolts (4), spacers (5), flat washers (6) and nuts (7) as shown in the illustration above.

* At this time, leave a gap of approximately 1 mm between the work table and the top of the box.

3. Close the covers (panel mounting assembly (2) and main P.C. board mounting plate (3)), and tighten them with the screws (1).

* The main P.C. board mounting plate (3) will be opened again during "3-11. Connecting the cords", so provisionally tighten it with the screw (1).

4. Install the power switch (8) with the two screws (9).

5. Secure the power switch cord with the five staples (10).

Note

- Secure the motor cord with staples in such a way that it does not cross over the outlet port of the cooling fan (11)
- Some specifications are not supplied with an accessory power switch (10). For these specifications, connect a power switch which satisfies the necessary regulations in the country of use.

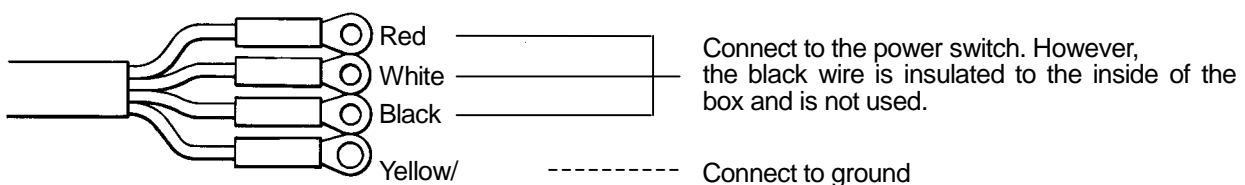

0064Q

3-4. Installing the rubber cushions

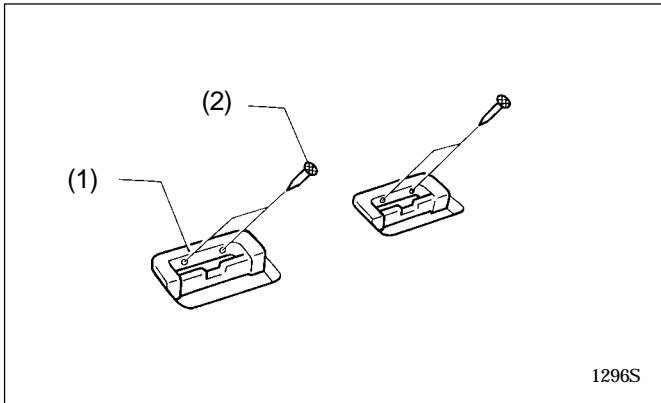

Install the rubber cushions (1) with the nails (2).

* Install so that the head of the nail does not protrude from the rubber surface.

3-5. Installing the oil pan

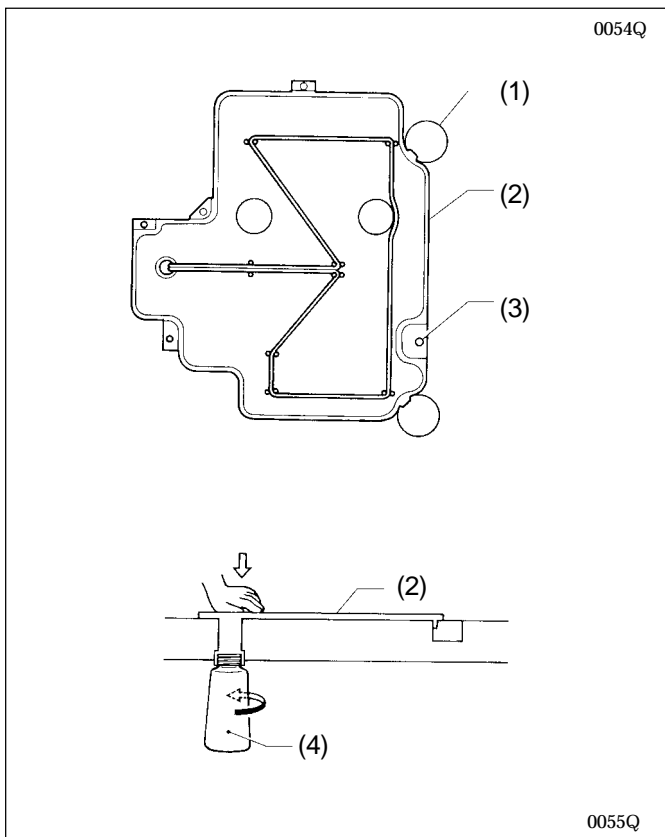

0054Q

0055Q

1. Insert the tabs of the oil pan (2) into the holes for the table (1), and then secure it in place with the five nails (3) so that the oil pan (2) is not at an angle.
2. While pushing the oil pan (2) down from above, screw in the oil container (4).

3-6. Installing the cushions

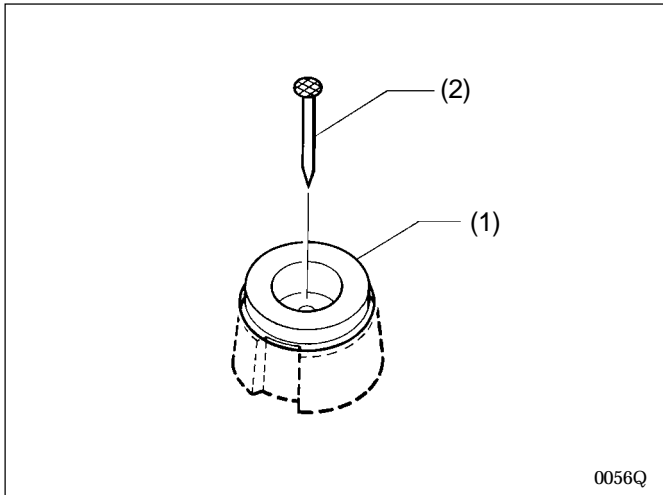

Place the two cushions (1) into the holes in the work table, and secure them in place with the nails (2).

- * Install so that the head of the nail does not protrude from the rubber surface.

3-7. Installing the switching plate

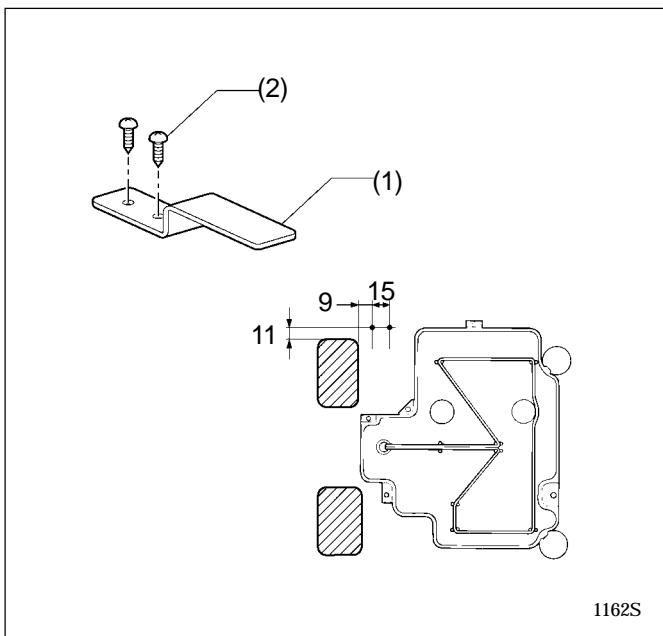

Install the switching plate (1) to the work table with the two wood screws (2) in the position shown in the illustration.

- * The switching plate and the switch bracket which is attached to the machine head prevent the sewing machine from starting when the machine head is tilted back. Therefore, this means that the sewing machine will not start if the switching plate is not installed.

3-8. Installing the machine head

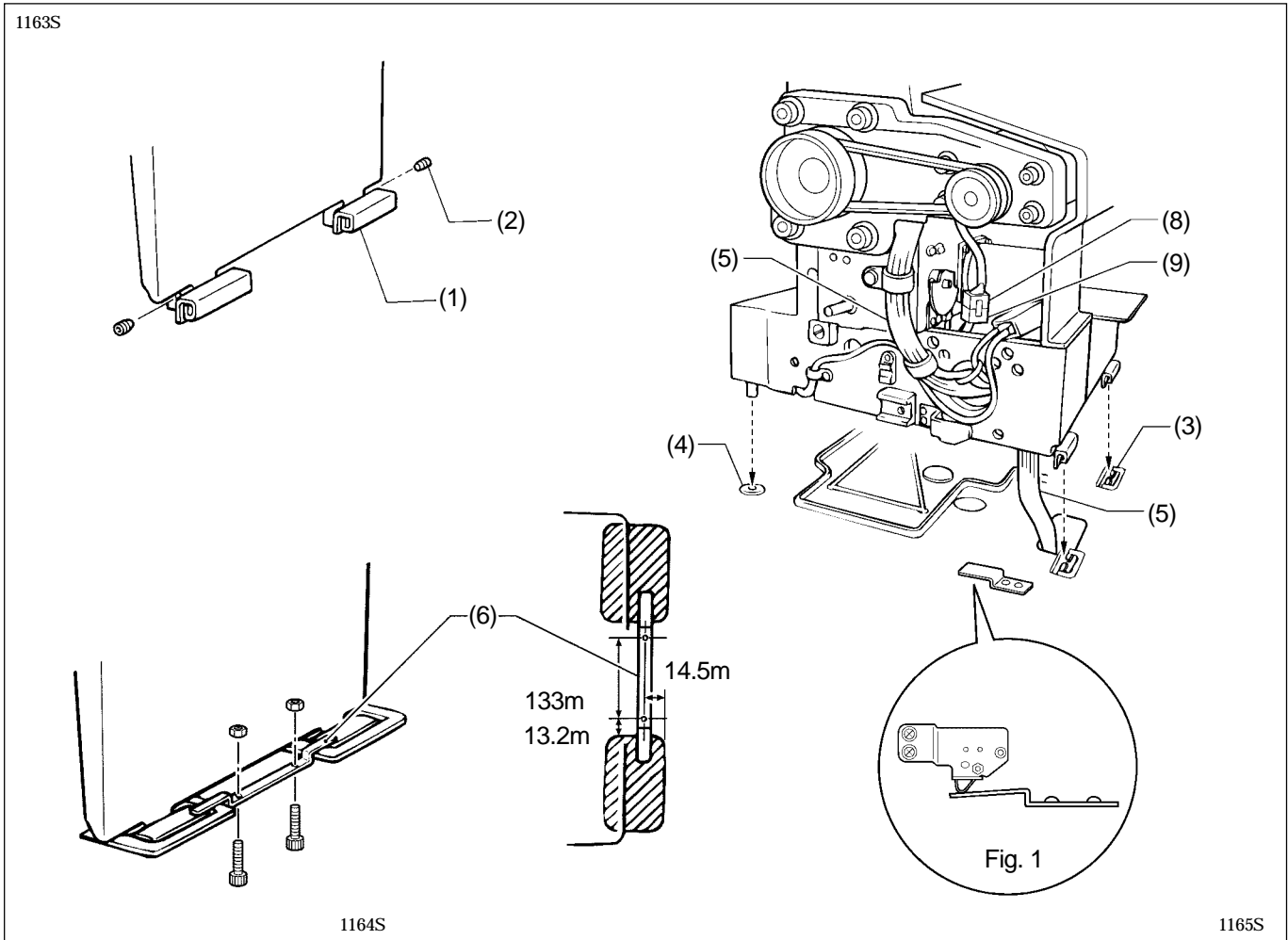

1. Insert the head hinges (1) into the machine head so that they are parallel, and then secure them with the two set screws (2).
2. Place the machine head gently on top of the rubber cushions (3) and cushions (4).

Note

Pull the cords (5) out as shown in the illustration above in order to prevent them from being clamped by the machine head.

3. Install the hinge presser (6) with the two bolts.
4. Check that the head position switch is turned on as shown in Figure 1.
5. Connect the motor cord connector (8) to the accessory cord connector (9).

3-9. Tilting the sewing machine head

BAS-311F-L, 326F-0 : Remove the X feed base cover (1) and the feed base cover support (3) (below) from the machine head before tapping the head rest (5) (next page) into the work table.

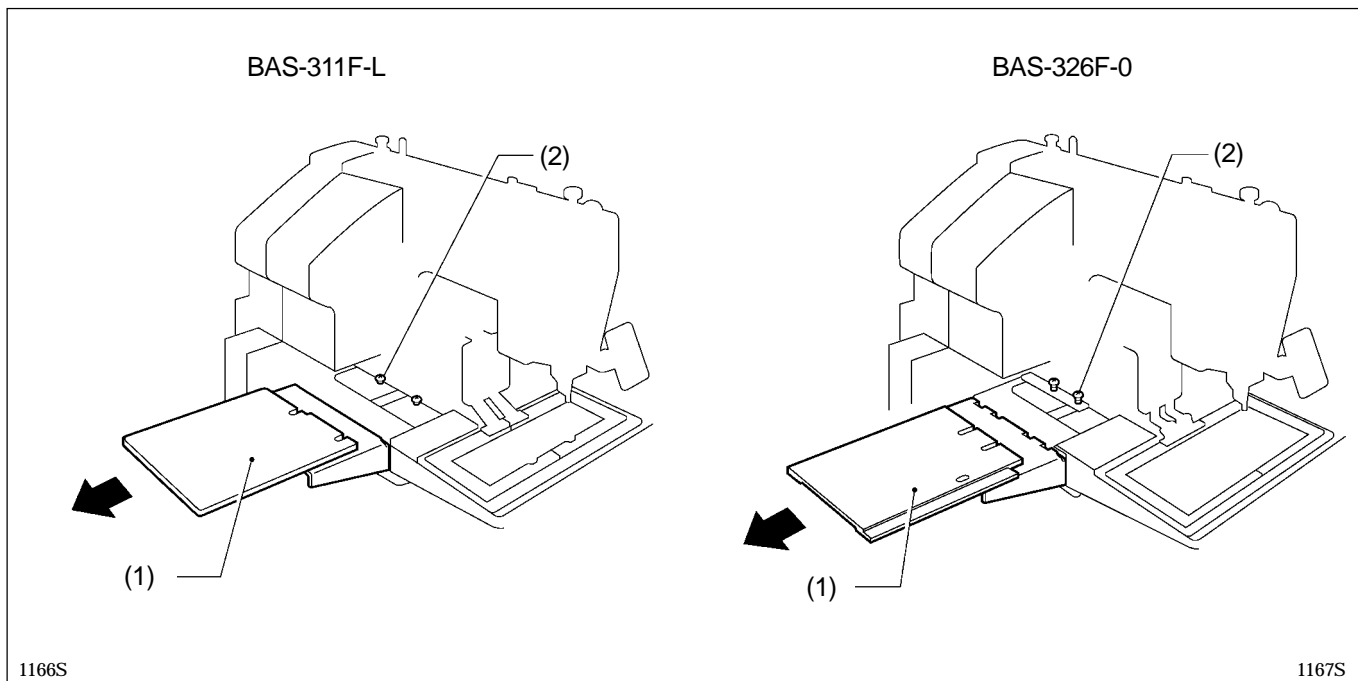

1. Loosen the screws (2) which are holding the X feed base cover L assembly (1) by about 2-3 turns, and then remove the X feed base cover L assembly (1) in the direction of the arrow in the illustration.

Note

The sewing machine is packed without the X feed base cover L assembly (1) installed.

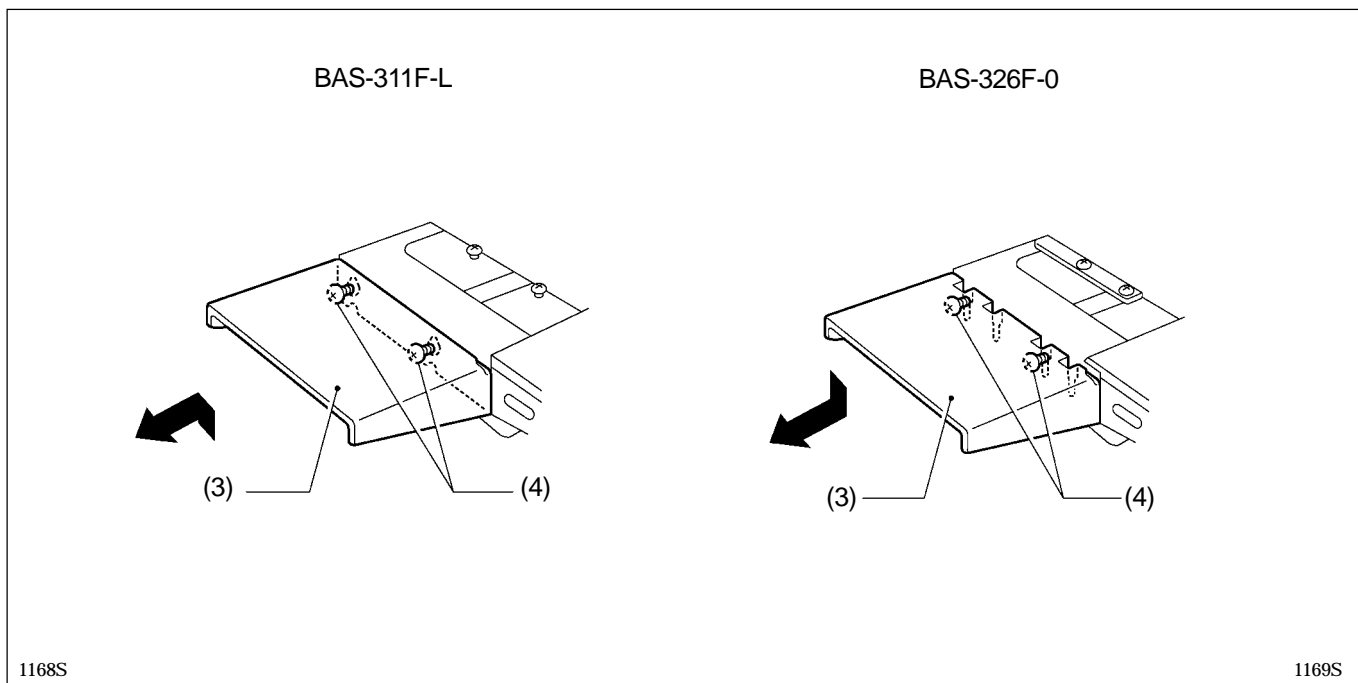

2. Loosen the screws (4) which are holding the feed base cover support (3) on the left of the sewing machine (when looking from the front of the sewing machine) by about 2-3 turns, lift the feed base cover support (3) up slightly (BAS-311F-L) or down slightly (BAS-326F-0), and then remove it in the direction of the arrow in the illustration.

Note

The sewing machine is packed without the feed base cover support (3) installed.

3. INSTALLATION

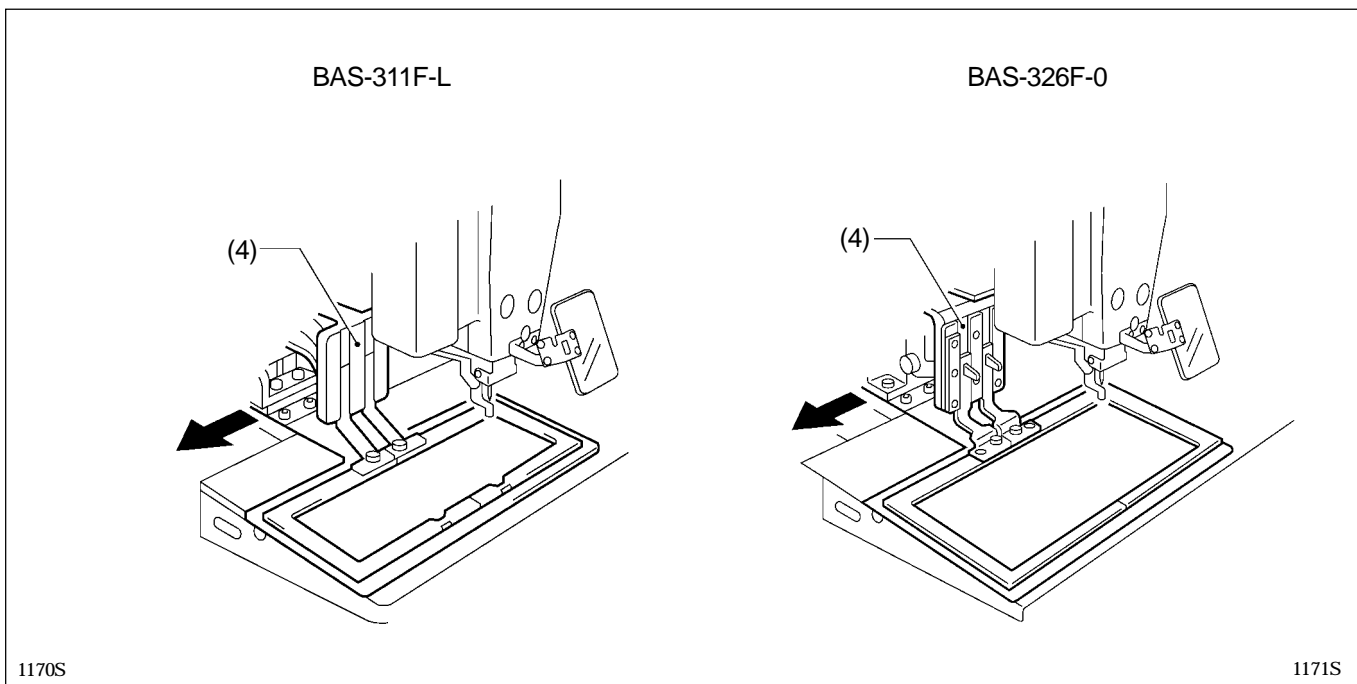

3. Move the presser arm assembly (4) as far as it will go in the direction of the arrow in the illustration (to the left when looking from the front of the sewing machine).

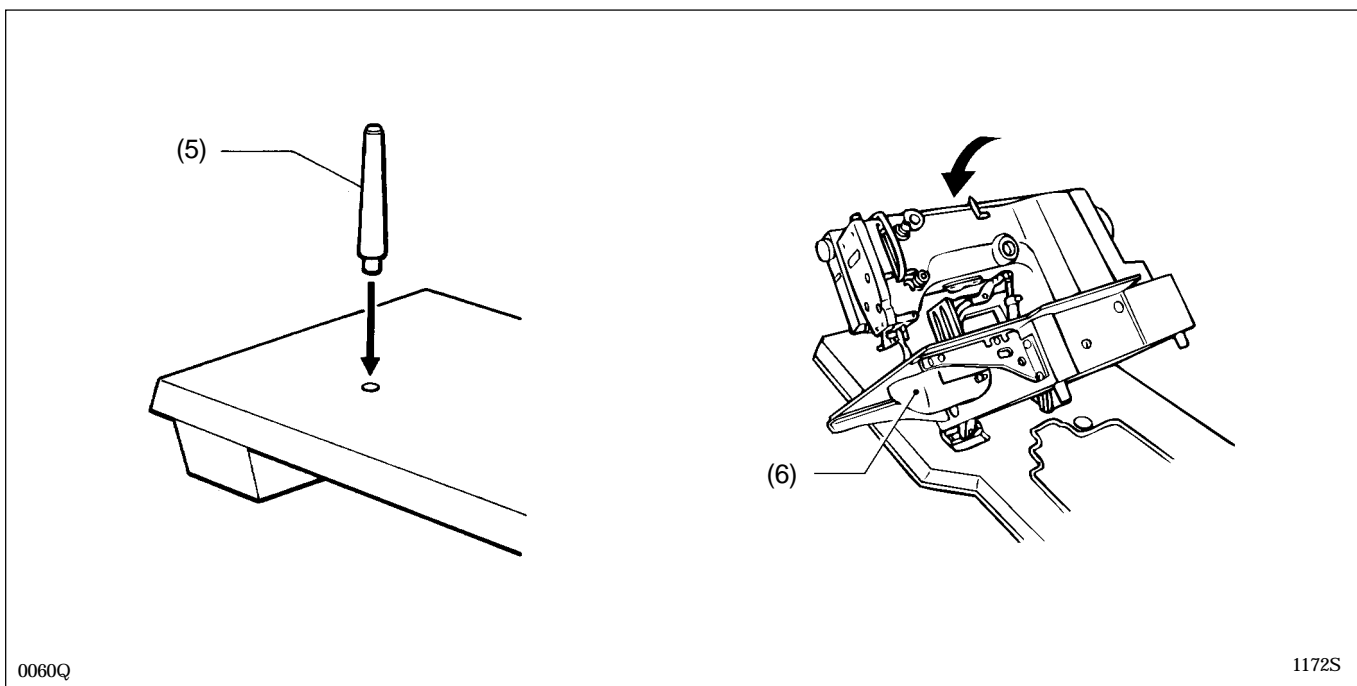

4. Tap the head rest (5) into the table hole.

Note

Tap the head rest (5) securely into the work table as far as it will go.

5. Stand at the left side of the table, and gently tilt the machine towards you. When returning the machine to the original position, be careful of the shuttle hook cover (6) and the cord.

Note

- Be sure to have two or more people there when tilting back the machine head and returning it to its original position.
- After tilting back the machine head, do not push the face plate or the pulley from above.

3-10. Connecting the ground wire

⚠ CAUTION



Be sure to connect the ground. If the ground connection is not secure, you run the risk of receiving a serious electric shock.

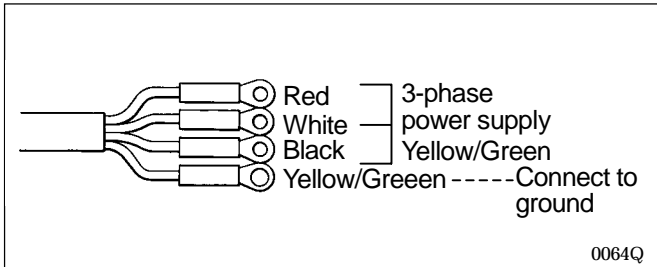

Connection method for 3-phase power supply

3-11. Connecting the cords (Installing the operation panel)

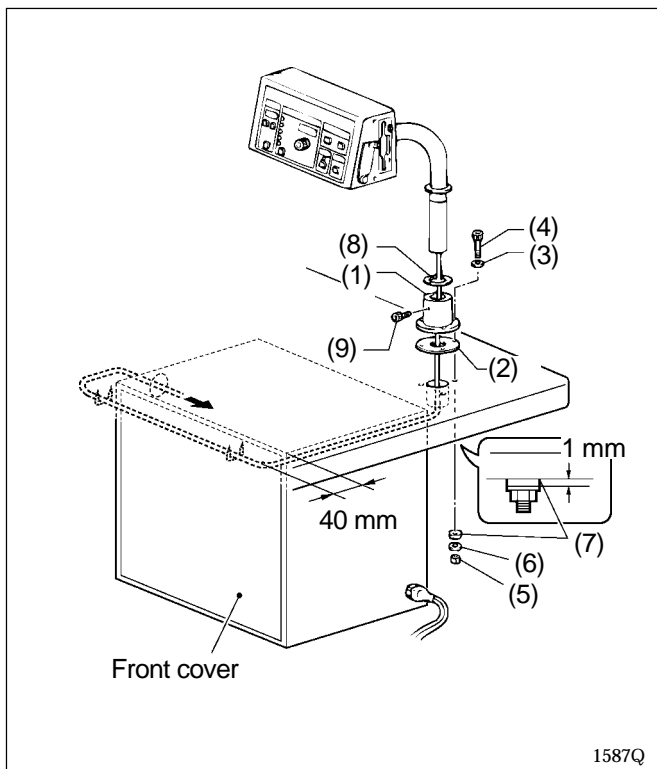

1. Assemble the operation panel stand (1) and cushion A (2). Then insert the bolts (4) together with the washers (3) into the three holes from above, and then tighten the nuts (5), washers (6) and cushion B (7) from below to secure the assembly.

Note

Tighten until the thickness of cushion B (7) becomes about 1 mm.

2. Pass the cords of the control panel assembly through the hole in the operation panel stand (1).
3. Attach the rubber sheet (8) to the hole in the operation panel stand (1) and then secure it with the bolt (9).
4. Insert the cord into the control box through the hole at the side of the box. Refer to page 13.
5. Secure the cord with the staples (in two places).

Note

When opening the front cover, check that the code does not touch it.

3. INSTALLATION

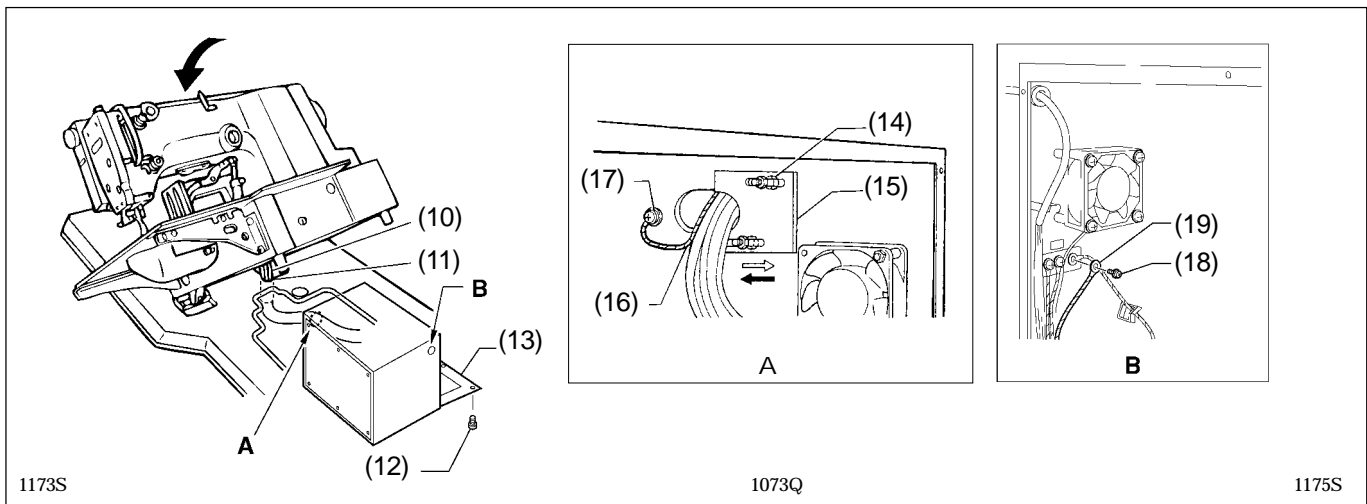

6. Gently tilt back the machine head. Refer to "3-9. Tilting the sewing machine head".

Note

- * Be sure to have two or more people there when tilting back the machine head and returning it to its original position.
- * After tilting back the machine head, do not push the face side or the pulley side from above.

7. Pass the cords (10) through the hole (11) near the hinge of the work table.

Note

If the cords are passed through the wrong hole, they may become damaged.

8. Gently return the machine head to its original position.

9. Remove the screws (12), and then open the control box cover (main P.C. board mounting plate (13)).

Note

When opening the cover, hold it securely so that it does not fall down.

10. Loosen the two screws (14), and then open the cord presser plate (15) in the direction of the white arrow and pass the cords (10) through the opening.

11. Loosen the screw (17), and then connect the ground wire (16) that is coming from the machine head as shown in the illustration.

12. Remove the screw (18), and then pass it through the terminal hole in the ground cord (19) from upper shaft motor. Then re-tighten the screw (18) so that the ground cord (19) is secured as shown in the illustration.

Note

Make sure that the ground connections are secure in order to ensure safety.

<BAS-311F-0 Solenoid type only>

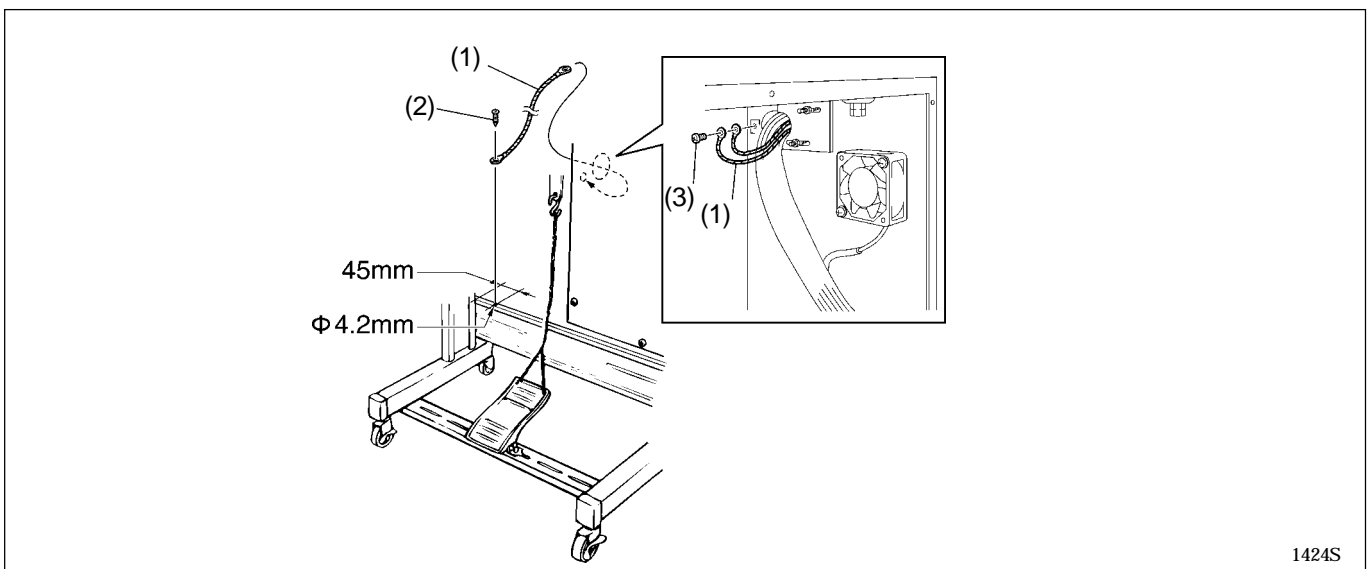

S1. Make hole in the beam as shown in the illustration above. (Button hole diameter is 4.2mm)

S2. Install the ground wire (1) (accessory) to the beam with a tapping screw (2) (accessory).

S3. Loosen the screw (3), and then connect the ground wire (1) that is coming from the beam as shown in the illustration.

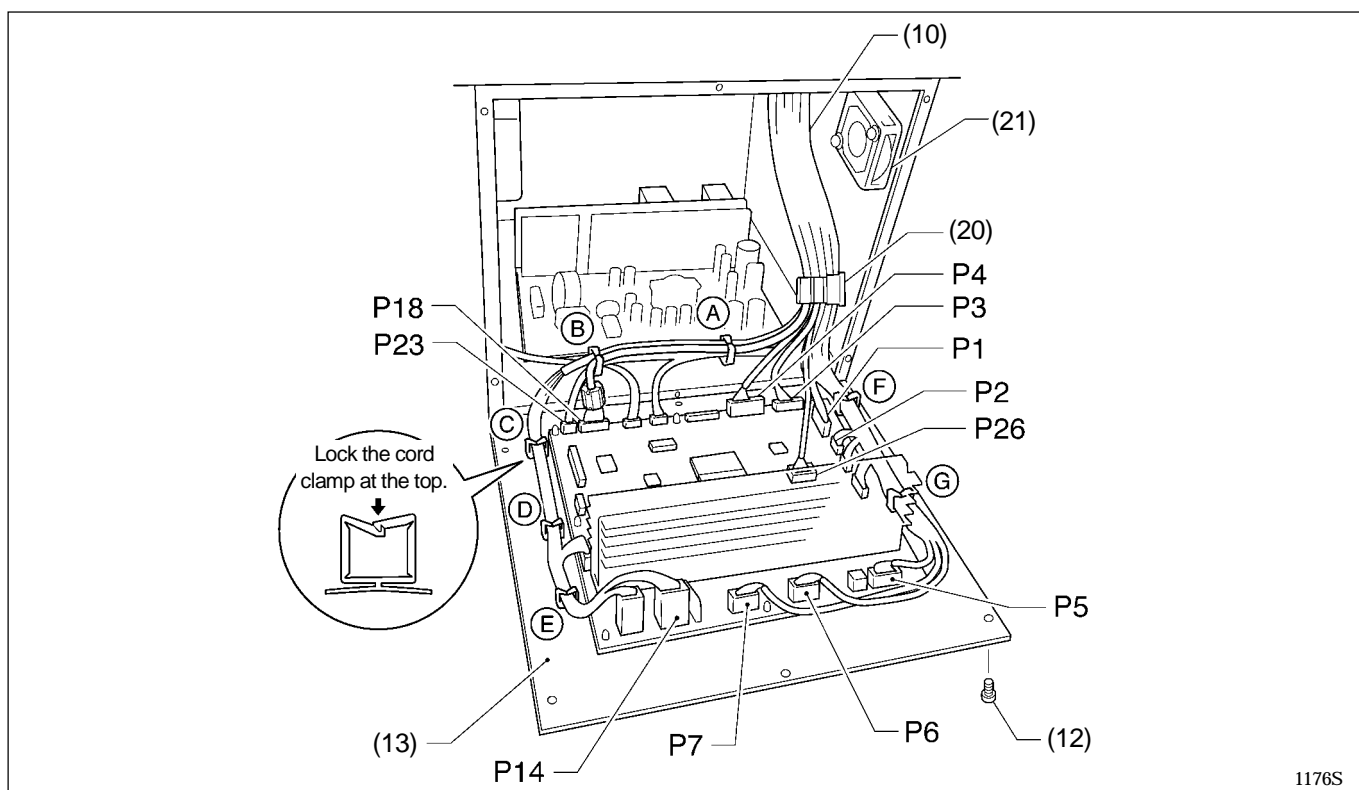

1176S

13. Securely connect connectors P1 to P7, P14, P18, P23 and P26 as indicated in table below.

Note

Check that the connector is facing the correct way, and then insert it firmly until it locks into place.

Furthermore, lock the cord clamp at the top.

Machine head connectors			Connection location on circuit board	Cord clamps used
Connection location	No. of pins	Cord mark		
X, Y, Sewing sensor	12-pin	[1]	P1 (ORG)	None
Synchronizer	5-pin	[2]	P2 (SYNCHRO)	F
EMERGENCY STOP switch	9-pin	[3]	P3 (HEAD)	None
Solenoid valve (for pneumatic)	12-pin	[4]	P4 (VALVE)	None
Solenoid	8-pin	[5]	P5 (SOL)	F, G
Presser foot				
Thread trimmer				
Wiper	5-pin	[6]	P6 (YPM)	F, G
Pulse motor, Y				
Pulse motor, X	5-pin (blue)	[7]	P7 (XPM)	F, G
Upper shaft motor	3-pin	None	P14 (UVM)	A, B, C, D, E
Operation panel	10-pin	[M]	P18 (PANEL)	A, B
Head position switch	3-pin	[23]	P23 (IMSW)	A, B
Machine specification select connector	10-pin	[26]	P26 (SELECT)	None

14. Secure the cord bundle (10) with the cord clamp (20).

Note

Check that the cords do not get pulled when the machine head is tilted back gently.

15. Close the cord presser plate (15) in the direction of the black arrow, and secure it by tightening the screws (14).

16. Install the control box cover (main P.C. board mounting plate (13)) with the six screws (12).

Note

Check that the cords do not come into contact with the fan (21) and that they are not clamped by the cover at this time.

3-12. Installing the belt cover

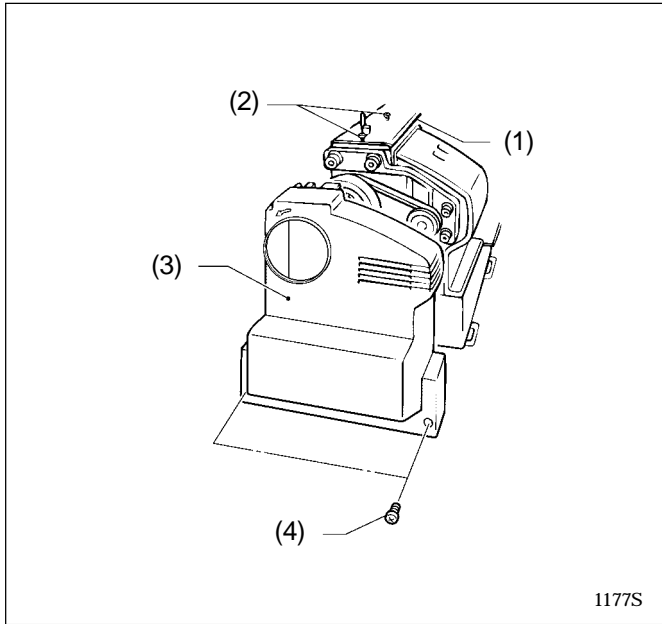

1. Loosen the two screws (2) of the upper cover (1).
2. Insert the belt cover (3) in the direction of the arrow, and then secure it with the two screws (2) and the two screws (4).

* it is not necessary to remove the belt cover (3) when tilting back the machine head.

3-13. Installing the foot switch

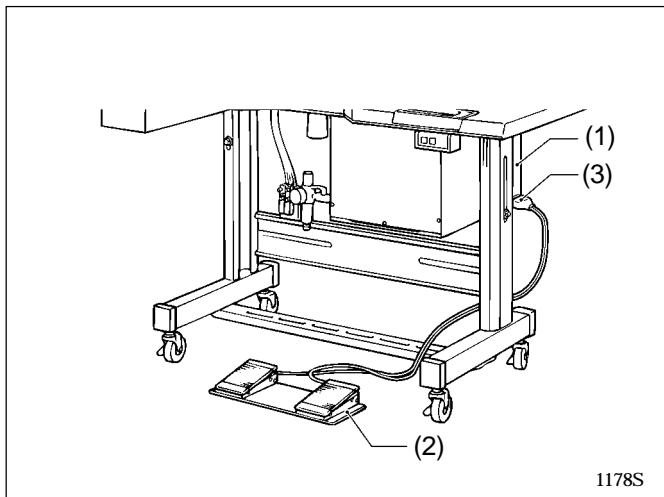

Insert the connector of the foot switch (2) into the connector (3) of the control box (1).

3-14. Installing the spool stand

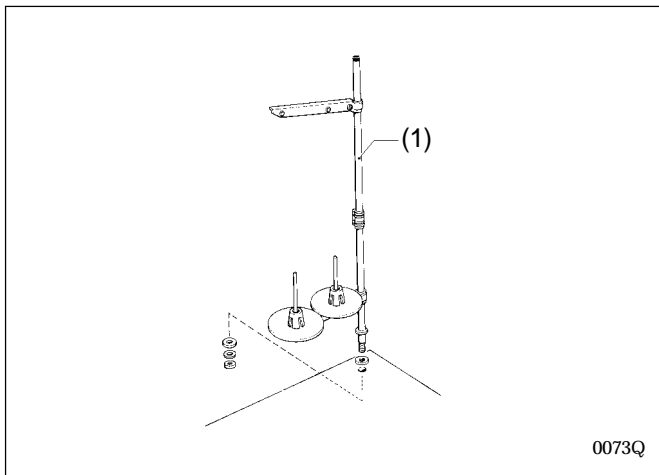

Install the spool stand (1) to the table.

3-15. Installing the eye guard

CAUTION



Attach all safety devices before using the sewing machine.
If the machine is used without these devices attached, injury may result.

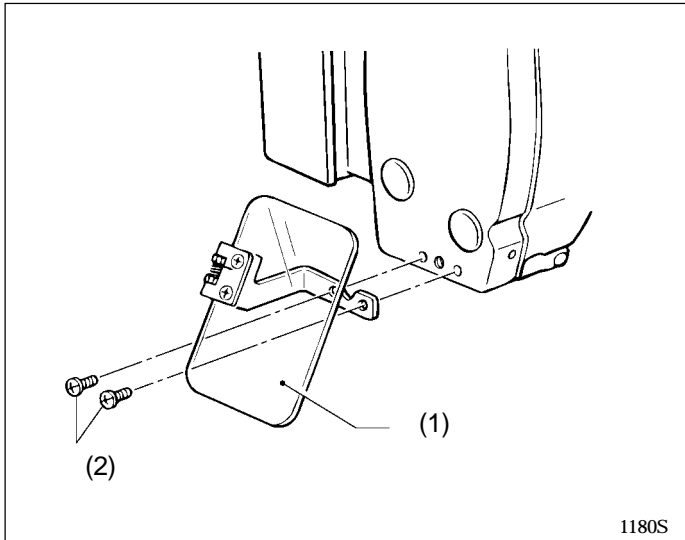

Install the eye guard assy (1) to the face plate with the two screws (2).

1180S

3-16. Installing the programmer (option)

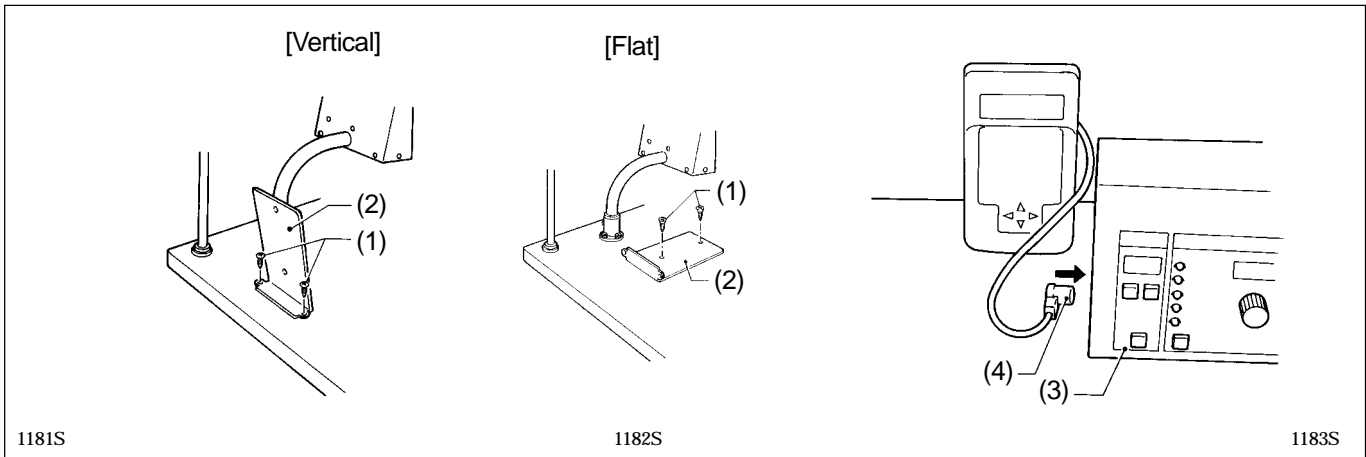

1. Install the programmer support (2) to the work table with the two screws (1).
2. Insert the programmer connector (4) securely into the left side of the operation panel (3).

3-17. Installing the work clamp lifter connecting rod (BAS-311F-0 solenoid type only)

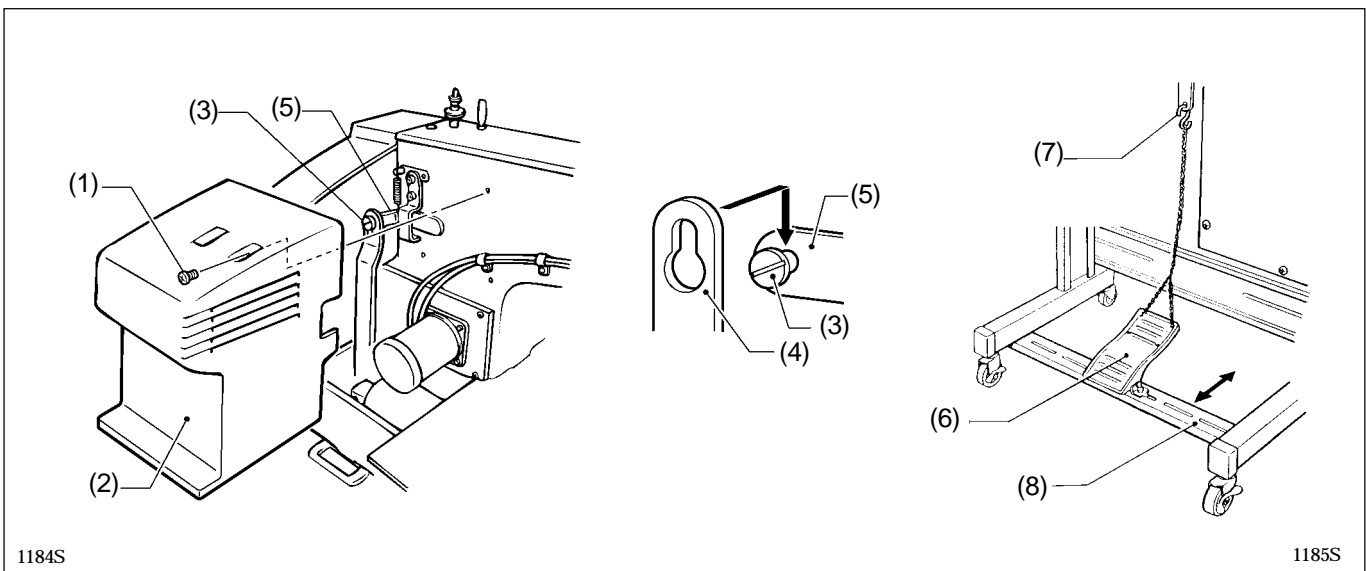

1. Remove the four screws (1), and then remove the side cover (2).
2. Install the work clamp lifter connecting rod (4) to the screw (3) on the work clamp lifter lever (5).
3. After installing, re-install the side cover (2) with the four screws (1).

Note

- Remove chain hooking back (7) which is attached to the work clamp lifter pedal (6) before tilting back the machine head.
- Move the treadle support base (8) back and forth to adjust so that the chain which is attached to the presser lifter connecting rod (4) and the presser lifter treadle (6) does not touch the cables.

3-18. Installing the feed base cover supports (BAS-311F-L, 326F-0)

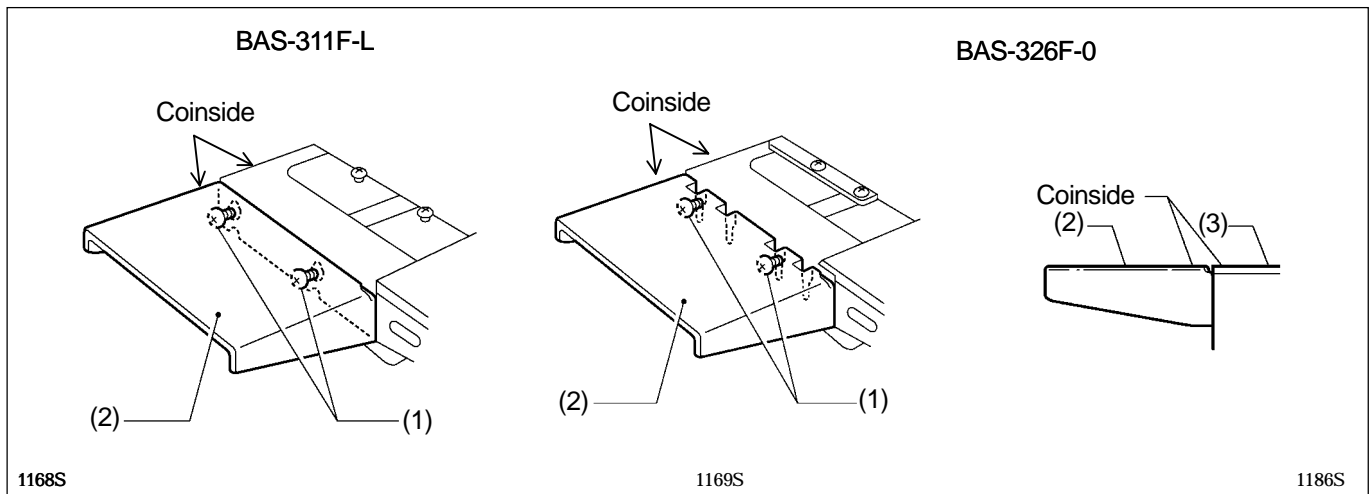

Loosen the four screws (1) on the side of the bed by about 2-3 turns, and then install the feed base cover supports (2) to the side of the bed so that the top surfaces of the feed base cover supports (2) (one each at left and right) are at the same height as the top surfaces of the X and Y feed base covers (3) (at left and right).

3-19. Installing the X feed base cover (BAS-311F-L, 326F-0)

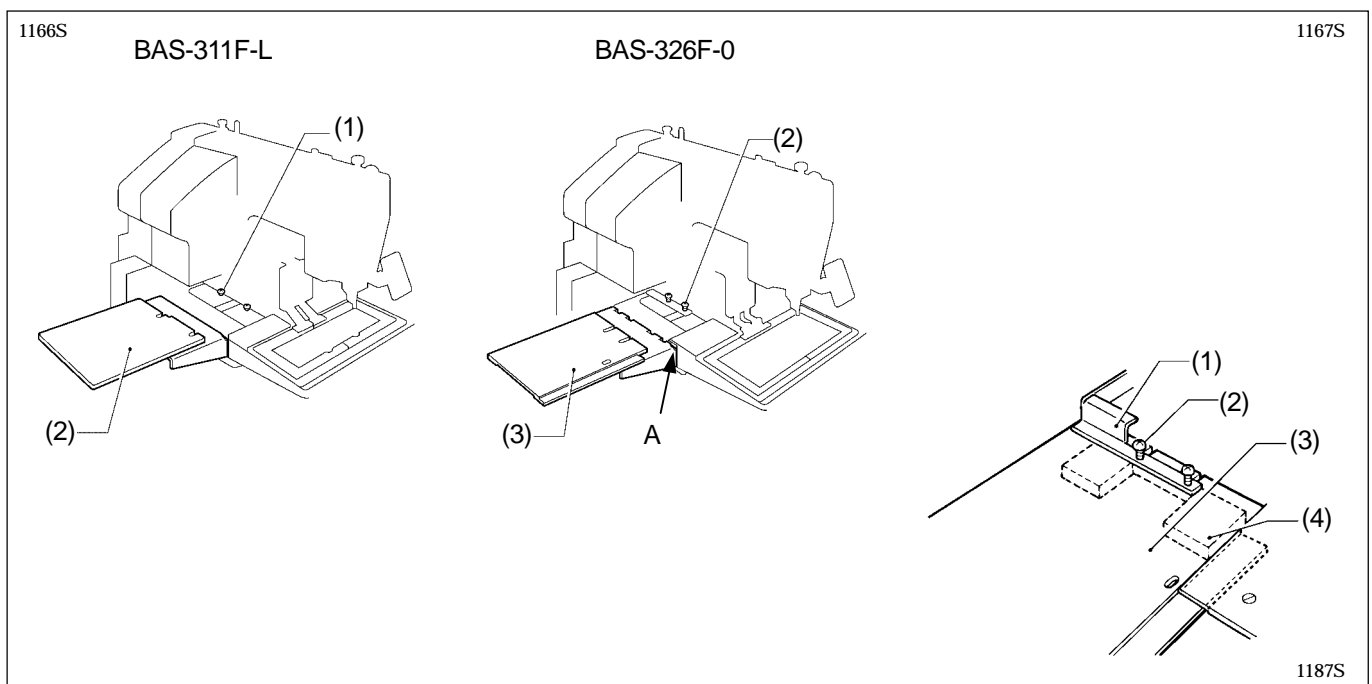

BAS-311F-L

Loosen the four screws (1) by about 2-3 turns, slide the X feed base cover (2) (one each at left and right) in the direction of the arrow in the illustration, and then tighten the screws (1).

BAS-326F-0

- Loosen the four screws (2) which are holding the bellows (1) by about 2-3 turns, and then slide the X feed base cover assemblies (3) (one each at left and right) in the direction of the arrow in the illustration into the gaps (section A) between the needle plate support plate and the X and Y feed base cover (at left and right).
- Lift the bellows (1) up slightly, clamp the tops and bottoms of the X feed base cover assemblies (3) (one each at left and right) between the bellows (1) and the X feed base (4) and then tighten the screws (2).

3-20. Connecting the tubes (pneumatic type only)

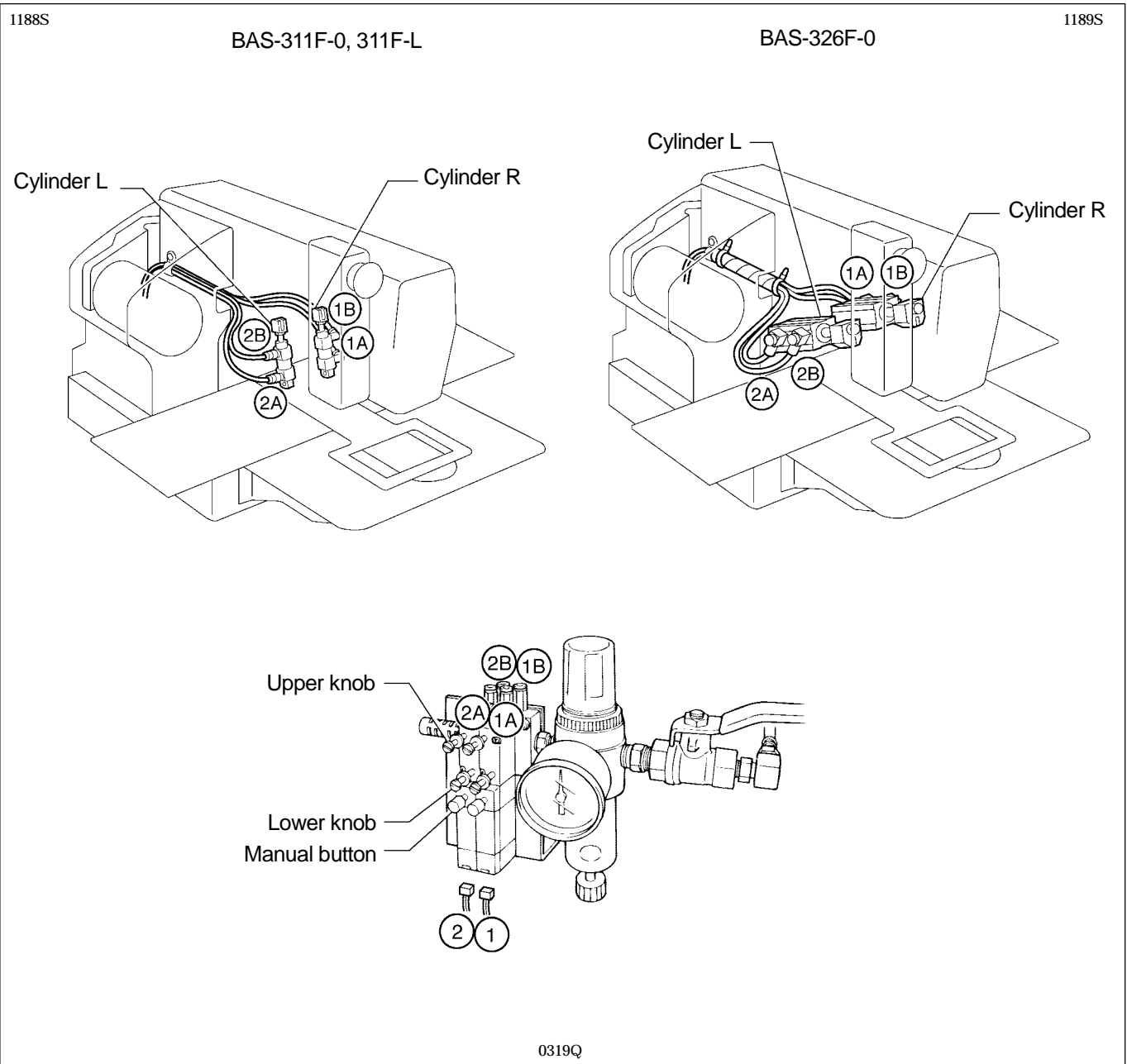

Connect each air tube to the position with the corresponding number.

3-20-1. Installing the air unit

Make sure that the air unit does not touch the control box or the work table leg.

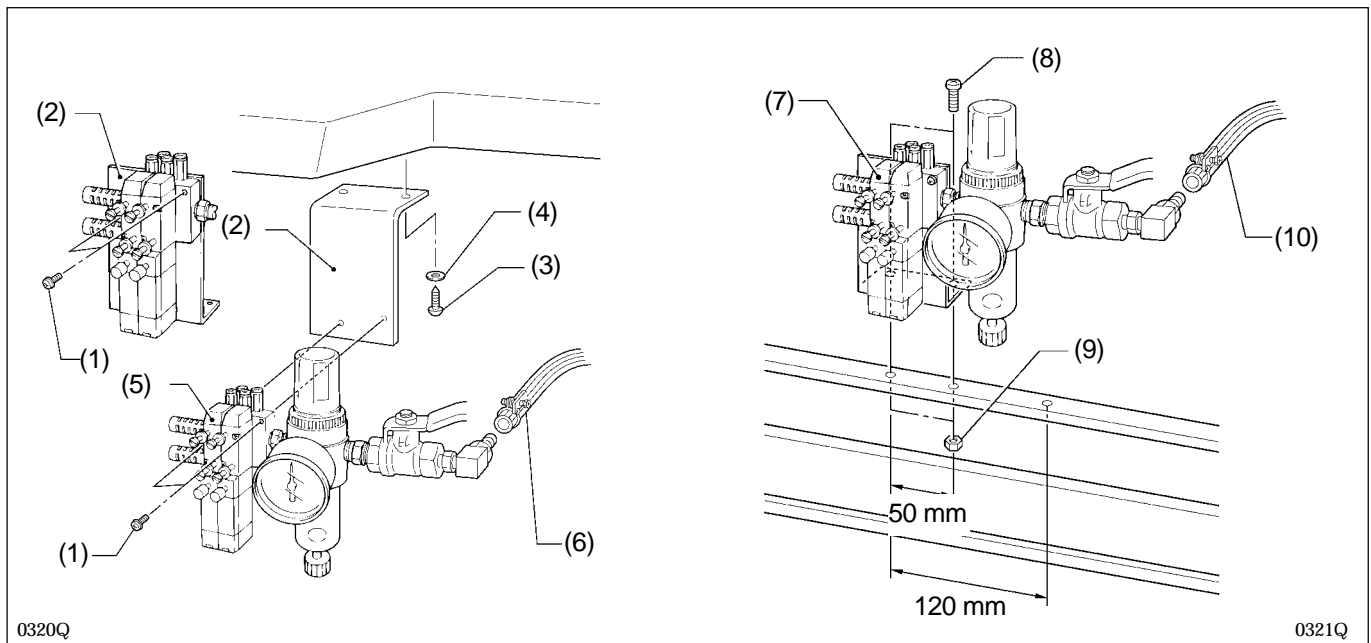

<When installing to the underside of the work table>

1. Remove the two screws (1) and the valve setting plate (2).
2. Turn the valve setting plate (2) upside down, and install it to the underside of the work table using the two wood screws (3) and washers (4) which are provided as accessories.
3. Install the air unit (5) to the valve setting plate (2) with two screws (1).
4. Connect the air hose (6).
5. Adjust the air pressure. (Refer to "9-10-4. Adjusting the air pressure".)

<When installing to a beam>

1. Make holes in the beam as shown in the illustration above. (Button hole diameter is 5.4 mm.)
Pneumatic work clampPitch 50 mm Reverse work clampPitch 120 mm
2. Install the air unit (7) to the beam with two accessory screws (8) and two bolts (9).
3. Connect the air hose (10).
4. Adjust the air pressure. (Refer to "9-10-4. Adjusting the air pressure".)

3-20-2. Adjusting the speed controller

The raising and lowering speeds for the work clamp can be adjusted by screwing the knobs on the valve in and out. Adjust the knob position to set the appropriate speed.

- If the upper knob is screwed inward, the work clamp raising speed becomes slower; if it is screwed outward, the raising speed becomes faster.
- If the lower knob is screwed inward, the work clamp lowering speed becomes slower, if it is screwed outward, the lowering speed becomes faster.
- The work clamp can be operated when the power is turned off by pressing the switch.
- If the manual button is pushed in and turned to the right, the work clamp can then be held in the raised condition.

Note

The valve knobs should be adjusted so that the left and right sides of the work clamp operate at the same speed.

4. LUBRICATION

⚠ CAUTION



Turn off the power switch before starting lubricating, otherwise the machine may operate if the foot switch is depressed by mistake, which could result in injury.



Be sure to wear protective goggles and gloves when handling the lubricating oil and grease, so that they do not get into your eyes or onto your skin, otherwise inflammation can result. Furthermore, do not drink the oil or eat the grease under any circumstances, as they can cause vomiting and diarrhoea. Keep the oil out of the reach of children.

- Note 1: Fill the machine with oil when the oil level is down to about one-third full in the oil sight glass. If oil is not added and the oil drops below this level, there is the danger that the machine may seize during operation.
- Note 2: Be sure to let the machine operate for a while after adding the oil.
- Note 3: If there is no more oil on the felt of the shuttle race base, problems with sewing may result, so add oil to the felt until it is slightly soaked.
- Note 4: Use only specified Brother oil (Nisseki Mitsubishi Sewing Lube 10N; VG10) for the machine oil.

Lubrication points

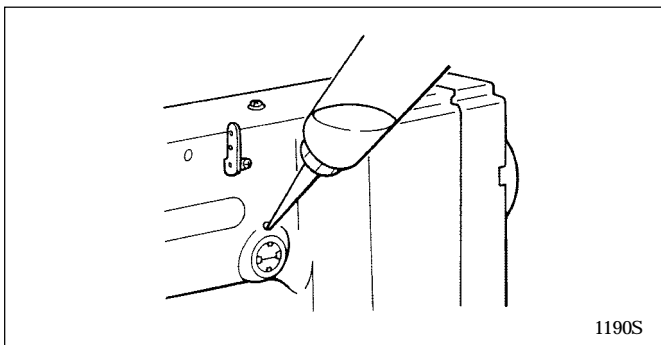

1. Fill the arm-side oil tank with oil.

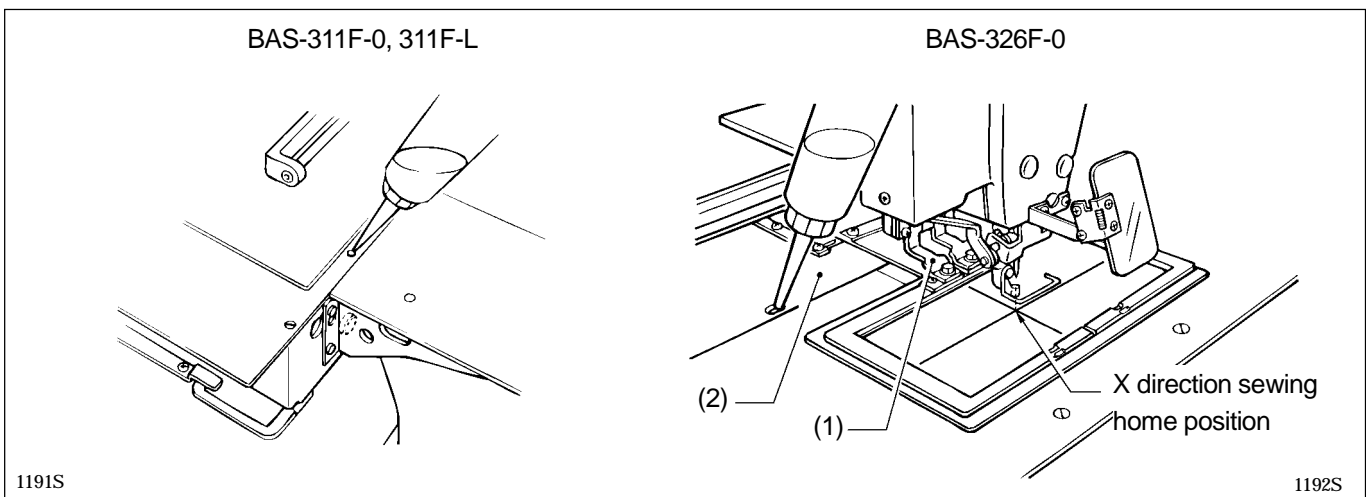

2. Fill the bed-side oil tank with oil.

BAS-326F-0

When filling the bed oil tank with oil, move the presser arm (1) to the X direction sewing home position so that the oil hole in the X feed base cover L assembly (2) is aligned with the oil hole in the bed, and then fill the bed oil tank with oil.

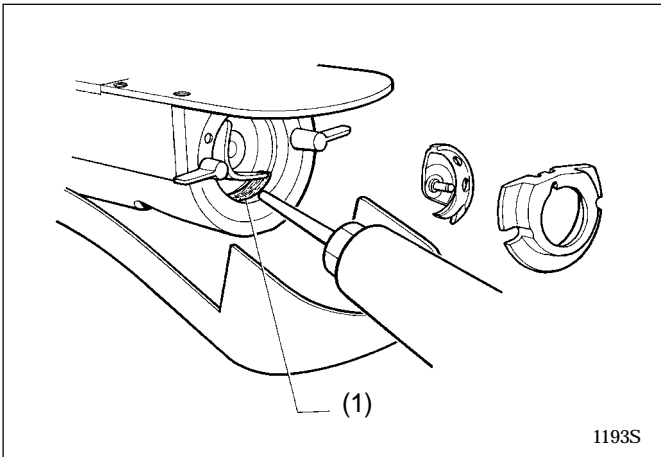

3. Add oil to the felt (1) of the shuttle race base.
 * When setting up the sewing machine and when it hasn't been used for an extended period of time, be sure to add 2-3 drops oil to the felt.

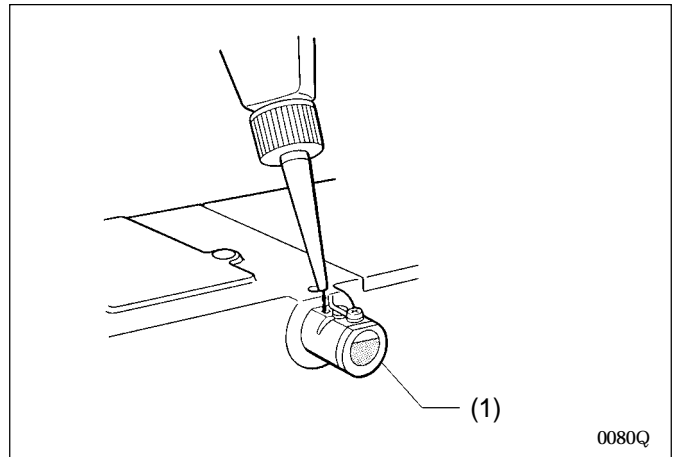

4. If using the liquid cooling tank (1), fill it with silicon oil (100 mm²/s).

5. CORRECT OPERATION

5-1. Selecting the needle and thread

Needle	Thread	Main application
DP X 5 # 9	#100 - #60	Knitted wear
DP X 5 # 16	#80 - #50	General clothing
DP X 17 # 19	#50 - #20	Denim
DP X 17 # 21	#50 - #20	Leather, denim
DP X 17 # 25	#20 - #4	Leather, seat belts

Different needles and threads are used for different sewing applications. Refer to the table at left for details on which needle and thread to select.

5-2. Installing the needle

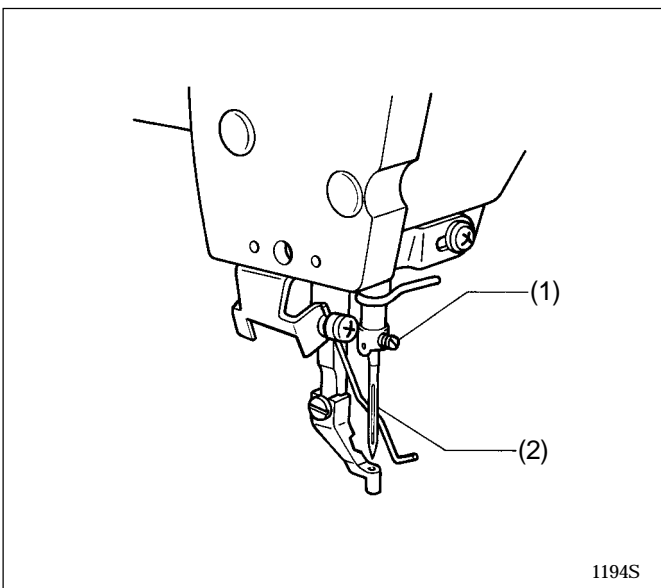

Loosen the set screw (1), insert the needle (2) as far as it will go so that the groove is facing toward you and then tighten the set screw (1).

5-3. Threading the upper thread

CAUTION



If the power switch needs to be left on when carrying out threading, be extremely careful to observe all safety precautions.

The machine may operate if the foot switch is depressed by mistake, which could result in injury.
(ex. Continuing sewing from a stopping point)

[When using cotton thread]

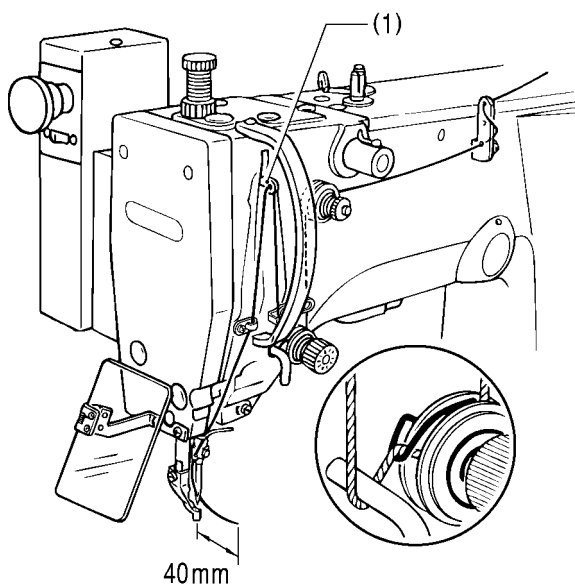

[When using the liquid cooling tank]

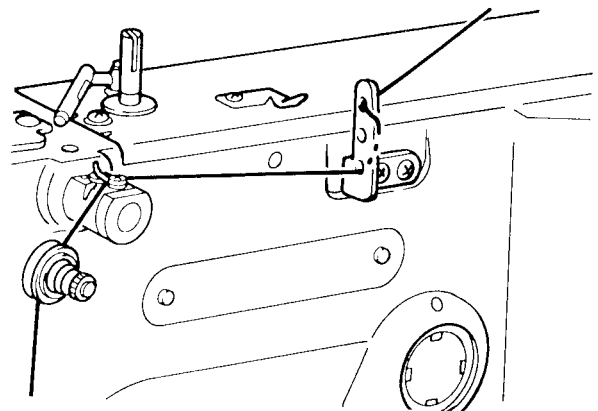

3569Q

1197S

Thread the upper thread correctly as shown in the illustration above.

Note

- Turn the machine pulley and raise the thread take-up lever (1) before threading the upper thread.
(This will make threading easier and it will prevent the thread from coming out at the sewing start.)
- When threading the thread through the needle, allow a distance of approximately 40 mm between the needle hole and the end of the thread. If the trailing length of the thread is too long, it may cause the thread to.

5-4. Winding the lower thread

 CAUTION

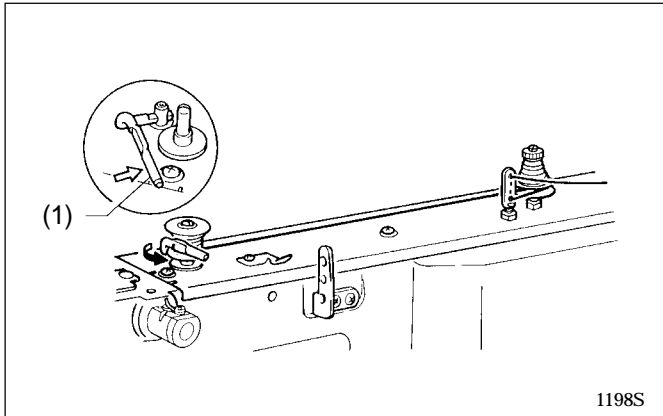

Do not touch or place anything against any of the moving parts while winding the lower thread, otherwise personal injury or damage to the machine may result.

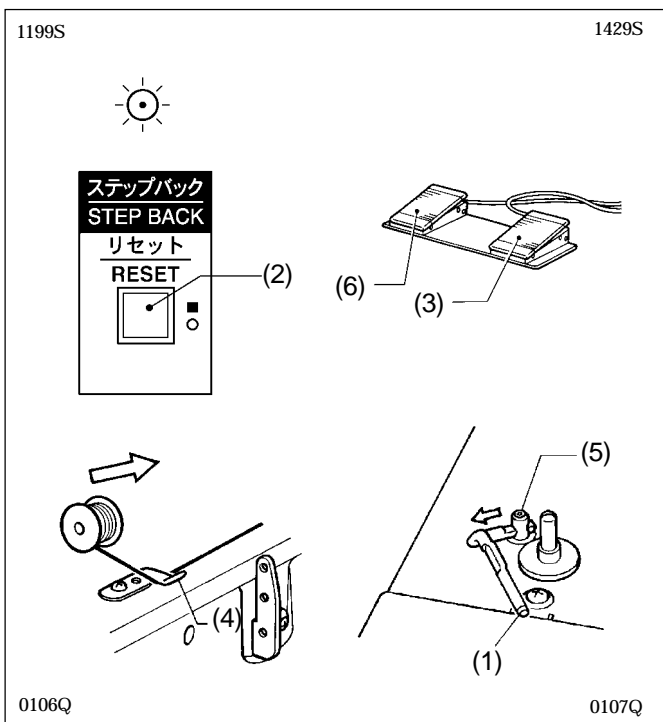

1. Place the bobbin all the way onto the shaft.
2. Thread the thread as shown in the illustration at left, wind the thread around the bobbin several times in the direction of the arrow, and then press the bobbin presser (1).
3. Turn on the power switch.
(The POWER indicator on the operation panel will illuminate.)
 - For solenoid specifications, lower the work clamp (depress the work clamp lifter pedal (6)).

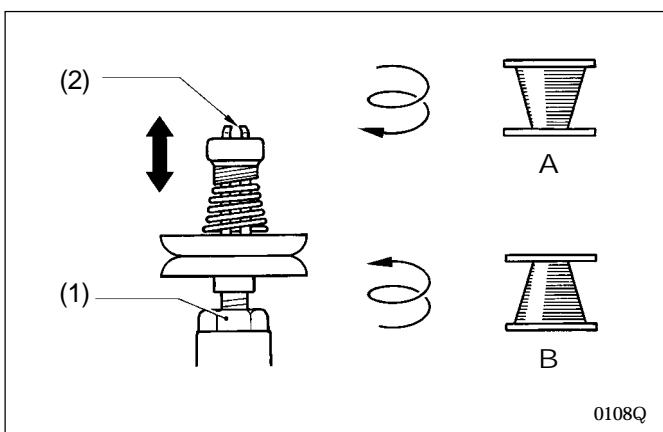

4. Check that the needle is not touching the presser foot, and then while pressing the STEP BACK switch (2), depress the foot switch (3) to start the machine. Keep depressing the foot switch (3) until the lower thread stops being wound onto the bobbin. Release the STEP BACK switch (2) after the machine starts operating.
If you release the foot switch before winding is completed, depress it once more while pressing and holding the STEP BACK switch (2).
5. The bobbin presser (1) will automatically return to its original position after a set amount of thread (80 - 90% of the bobbin capacity) has been wound on.
6. Release the foot switch (3).
7. Remove the bobbin, hook the thread onto the knife (4), and then pull the bobbin in the direction of the arrow to cut the thread.
8. To wind more thread onto the bobbin, loosen the set screw (5) and pull the bobbin presser (1) outward.



<< If the thread winds onto the bobbin unevenly >>

If the thread winds onto the bobbin unevenly, loosen the nut (1) and turn the bobbin winder thread tension stud (2) to adjust.

Note

If the thread winds on as shown in A, turn the bobbin winder thread tension stud (2) clockwise; if it winds on as shown in B, turn the bobbin winder thread tension stud (2) counterclockwise.

5-5. Replacing the bobbin case and threading the thread

CAUTION



If the power switch needs to be left on when carrying out replacing the bobbin, be extremely careful to observe all safety precautions.
The machine may operate if the foot switch is depressed by mistake, which could result in injury.
(ex. Continuing sewing from a stopping point)

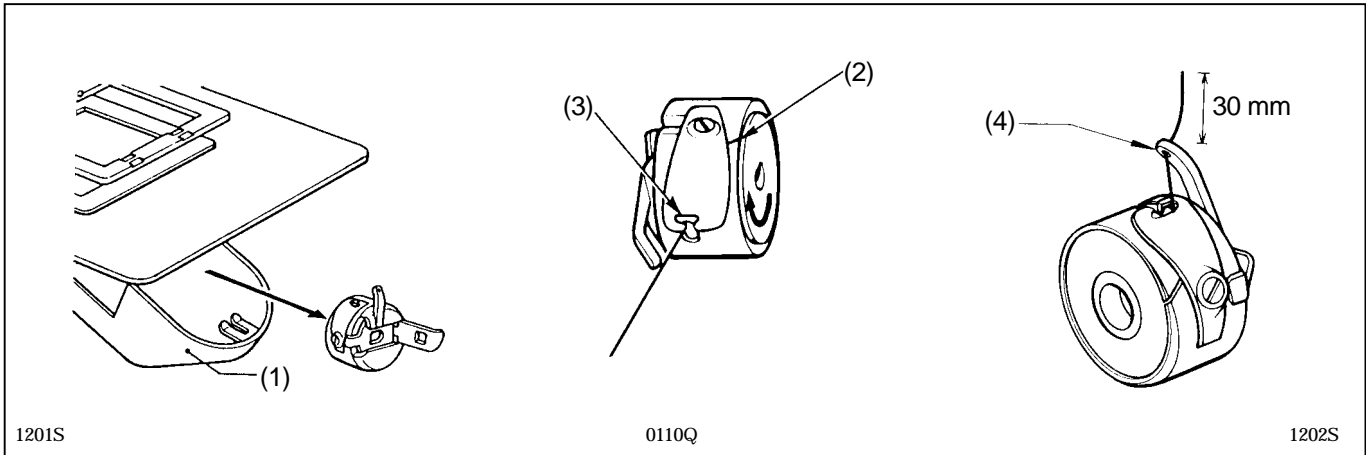

1. Pull the shuttle race cover (1) forward and then open the cover.
2. Lift the bobbin case latch and remove the bobbin case.
3. Insert a new bobbin into the bobbin case, and then pass the thread through the slot (2) and pull it out from the thread hole (3). Check that the bobbin turns in the direction of the arrow when the thread is pulled at this time.
4. Pass the thread through the lever thread hole (4), and then pull out approximately 30 mm of thread.

5-6. Sewing conditions and thread tension

5-6-1. Sewing conditions

Specifications	BAS-311F-0, 326F-0		BAS-311F-0	BAS-311F-L
	For heavy materials	For medium materials	For extra heavy materials	For heavy materials (denim)
Upper thread	# 20 or equivalent	# 50 or equivalent	# 4 or equivalent	# 20 or equivalent (cotton)
Lower thread	# 20 or equivalent	# 60 or equivalent	# 4 or equivalent	# 20 or equivalent (cotton)
Upper thread Tension (N)	1.4 - 1.8	1.0 - 1.3	4.5 - 5.0	1.4 - 1.8
Lower thread Tension (N)	0.2 - 0.3	←	1.0 - 1.2	0.3 - 0.4
Thread take-up spring height (mm)	7 - 10	←	0	7 - 10
Thread take-up spring tension (N)	0.5 - 1.2	0.15 - 0.35	-	0.5 - 1.2
Pre-tension (N)	0.1 - 0.3	←	0.3 - 0.5	0.1 - 0.3
Needle	DP X 17 # 19	DP X 5 # 16	DP 17 # 25	DP X 17 # 19
Normal sewing speed	2000 rpm	2000 rpm	1300 rpm	2000 rpm

The sewing conditions given in the above table may need to be changed depending on the article being sewn.

5-6-2. Lower thread tension

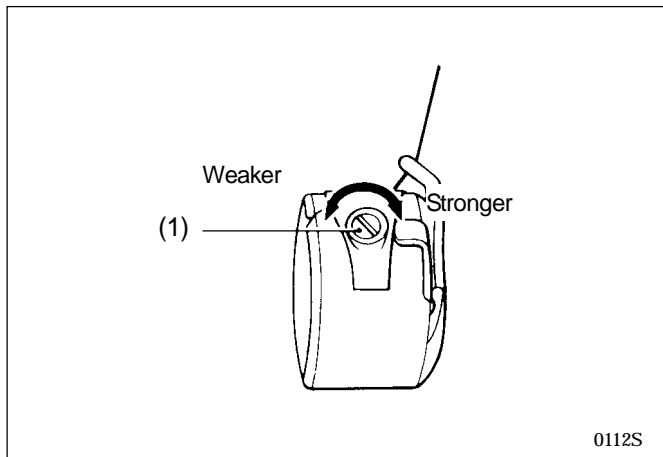

Set the lower thread tension to as weak a tension as possible and so that the bobbin case drops by its own weight when the end of the thread is held. Turn the adjusting screw (1) to adjust the tension.

Note

If the lower thread tension is too weak, it may not be possible to cut the lower thread properly during thread trimming.

5-6-4. Thread take-up spring height

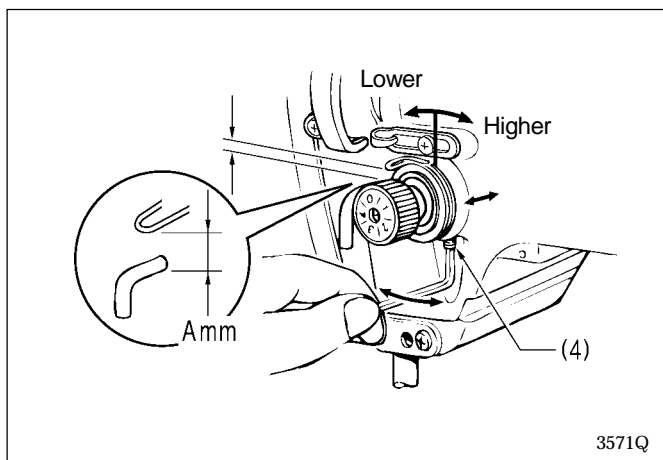

Loosen screw (4) and turn the entire thread take-up unit to adjust so that the height of the thread take-up spring is A mm. (Refer to "5-6-1. Sewing conditions")

5-6-6. Adjusting arm thread guide R

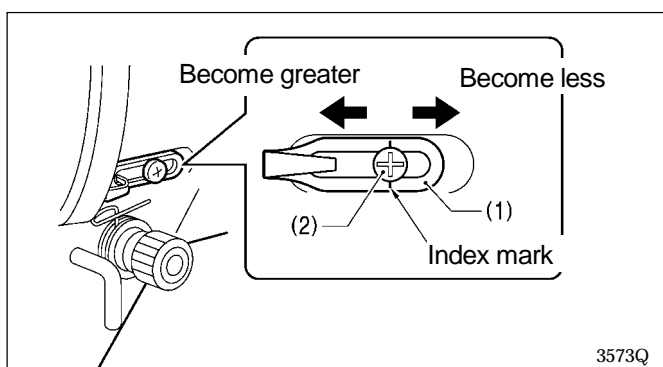

5-6-3. Upper thread tension

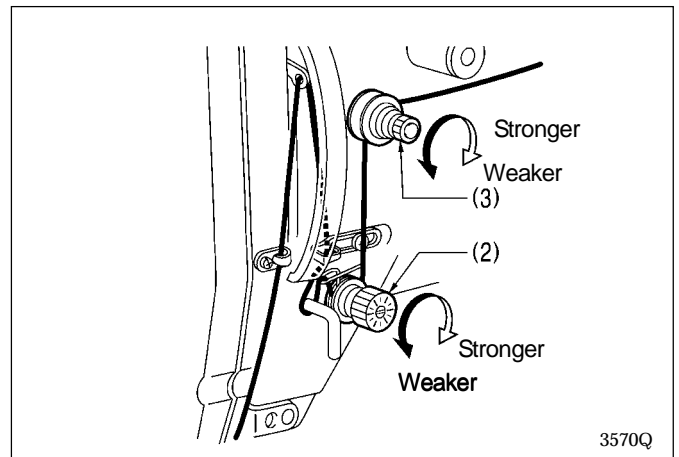

Turn the tension nut (2) (main tension) to adjust the tension as appropriate for the material being sewn.

Furthermore, turn the thread nut (3) (sub-tension) to adjust the remaining length of upper thread to approximately 40 mm.

5-6-5. Thread take-up spring tension

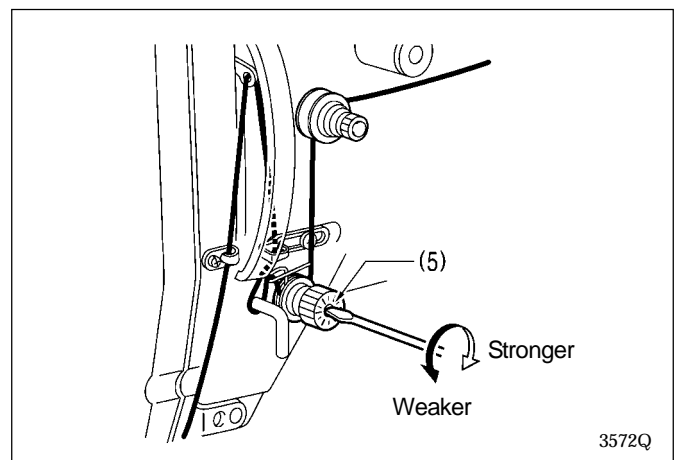

Adjust the thread take-up spring tension by turning the tension stud (5) with a screwdriver.

The standard position of arm thread guide R (1) is when the screw (2) is aligned with the index mark.

To adjust the position, loosen the screw (2) and then move arm thread guide R (1).

- When sewing thick material, move arm thread guide R (1) to the left. (The thread take-up amount will become greater.)
- When sewing thin material, move arm thread guide R (1) to the right. (The thread take-up amount will become less.)

6. USING THE OPERATION PANEL

6-1. Explanation of panel

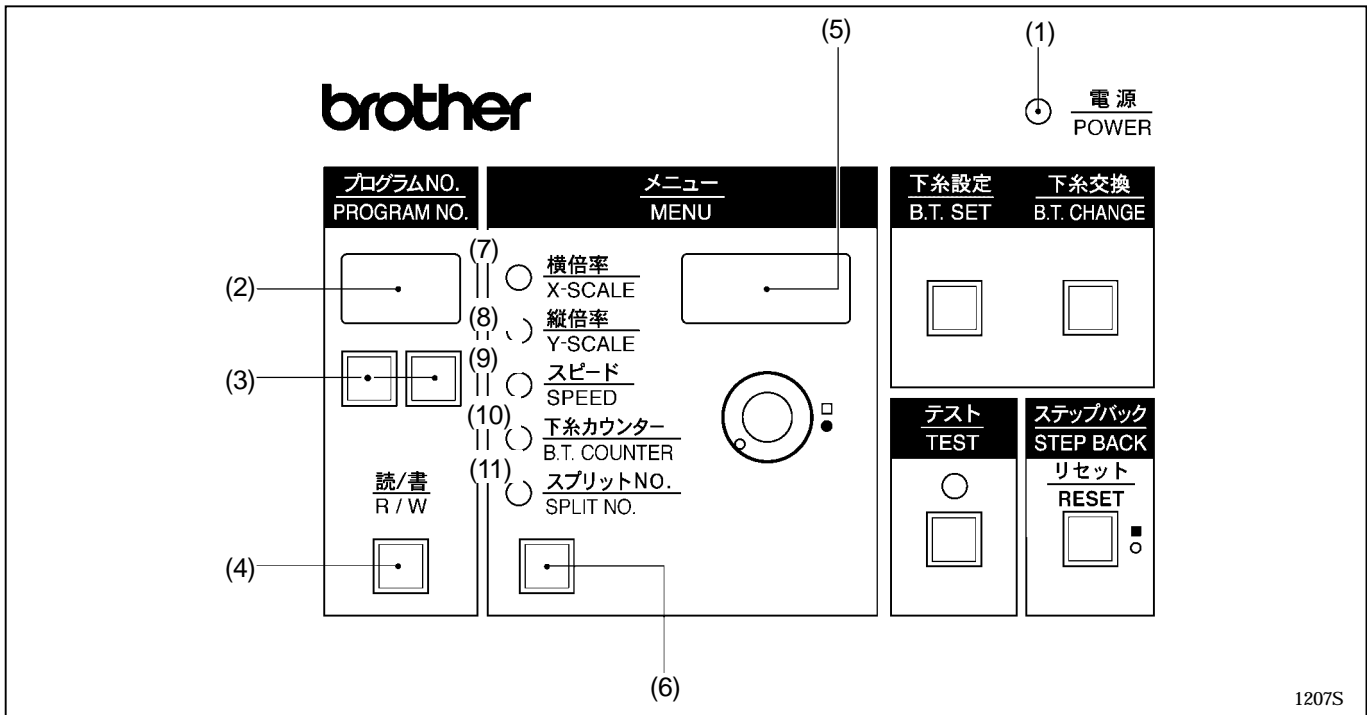

- (1) POWER indicator When the power is turned on, the indicator lights to show that the power is on.
- (2) PROGRAM No. display..... Displays the program number 00 - 99.
- (3) Program select switch Used to select the program number when reading a program from or writing a program to disk.
- (4) Program Read/Write switch Used to read a program from floppy disk, or to write a newly programmed stitch pattern to floppy disk.
Up to ten patterns (00 - 99) can be stored on each disk.
- (5) Display screen Used to display data such as menus, errors and memory switch settings.
- (6) Menu switch..... Used to select the desired menu (scale, speed, bobbin thread counter, split No.).
One of the indicators (7) - (11) illuminates to indicate the menu selected, and the setting for that menu then appears on the display screen (5).
The illuminated indicator changes in the following order each time the switch is pressed.

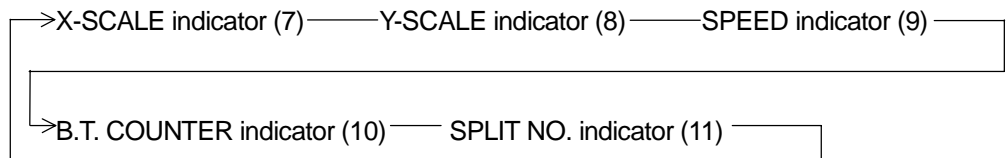

- (7) X-SCALE indicator Illuminates when X-scale mode has been selected using the menu switch (6).
- (8) Y-SCALE indicator Illuminates when Y-scale mode has been selected using the menu switch (6).
- (9) SPEED indicator..... Illuminates when speed mode has been selected using the menu switch (6).

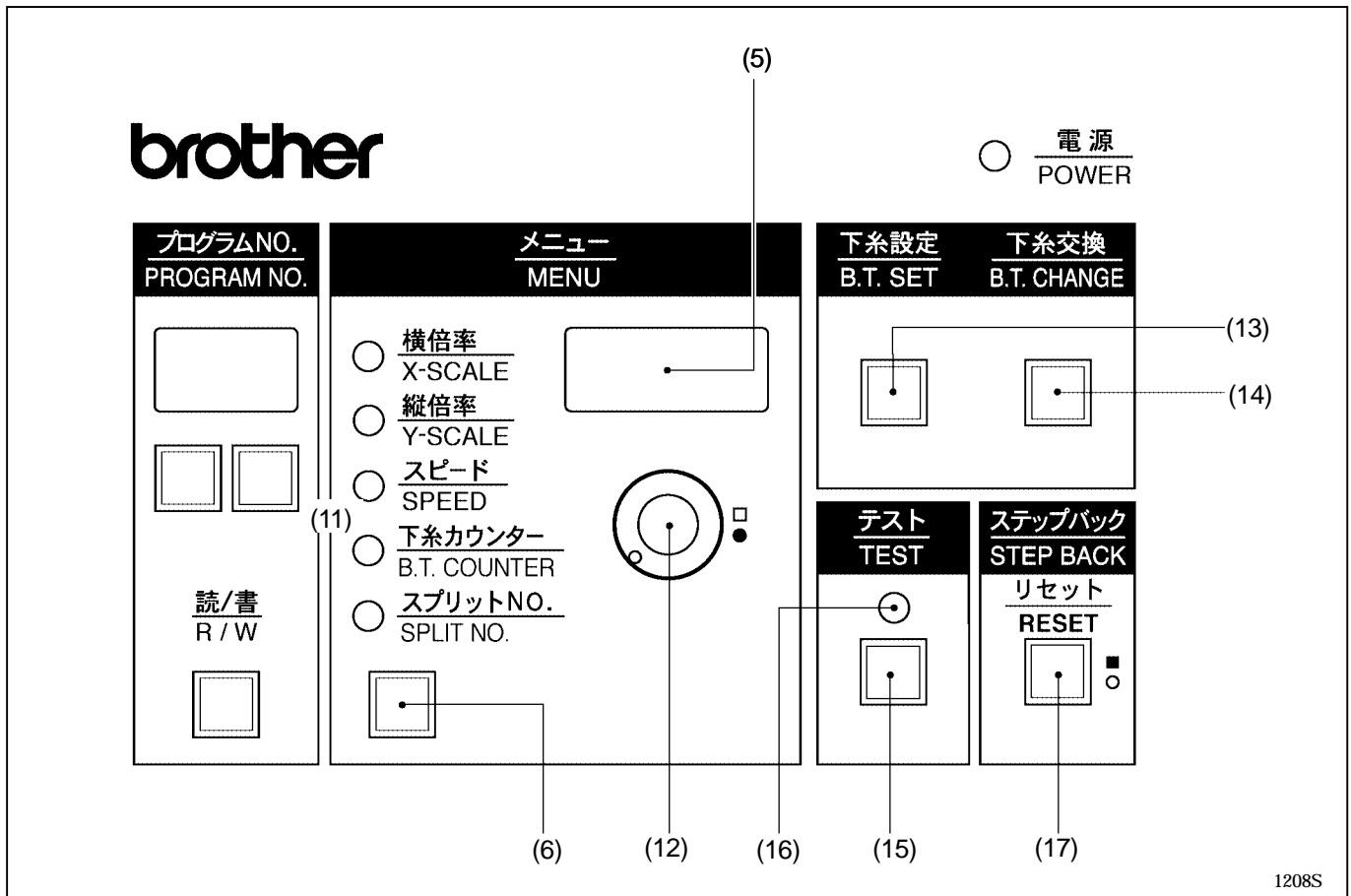

1208S

- (10) Bobbin Thread COUNTER Illuminates when bobbin thread counter mode has been selected using the menu indicator switch (6).
- (11) SPLIT NO. indicator Illuminates when split No. mode has been selected using the menu switch (6).
- (12) Dial The setting shown on the display screen (5) can be changed by turning this dial while pressing the STEP BACK switch (17).
- (13) Bobbin Thread SET switch Used to store the number of work pieces displayed in the bobbin thread counter to floppy disk.
- (14) Bobbin Thread CHANGE switch Used to continue sewing after replacing the bobbin thread. (An alarm will sound when the counter reads <000>. Sewing is not possible when the counter reads <000>.) (Refer to "6-8. Using the bobbin thread counter".)
- (15) TEST switch Used to move the feed mechanism only in order to confirm a programmed stitch pattern.
- (16) TEST indicator Lights when the TEST switch is pressed.
- (17) STEP BACK switch (RESET switch) Used when winding a fresh bobbin, or when correcting a stitch pattern due to a broken needle thread. Also used to reset error displays.

6-2. Using the floppy disk

<Compatible types of floppy disk>

Data type	No. of stitches programmed	Data resolution	Disk	Format	Write enabled
300E type (300F type)	20,000 stitches per pattern 100 patterns Up to a maximum of 360,000 stitches	0.05 mm/pulse	2HD	1.44 MB	Yes
Tajima embroidery data	50,000 stitches per pattern	0.1 mm/pulse			No
Old 300A type	4,000 stitches per pattern 10 patterns Up to a maximum of 40,000 stitches	0.1 mm/pulse	2DD	Automatically formatted	Yes
Old 300 data	2,000 stitches per pattern 10 patterns Up to a maximum of 20,000 stitches	0.2 mm/pulse			No

- The above four types of data can all be read, but when writing to disk, all data is automatically converted to 300F, 300E data when writing to 2HD disks and 300A data when writing to 2DD disks.
- When using a 2HD disk, use a disk which has been pre-formatted as a 1.44 MB disk. (The programmer can be used to format these disks. Refer to the programmer instruction manual for details.)
- TFD embroidery data can be embroidered after it has been converted by the programmer to BAS-300F and BAS-300E data.
- Restriction on using 2DD floppy disks.
In order to maintain compatibility with the old 300A series, the following restrictions have been placed on the use of the new functions which have been added to the E series.

Restricted function	A series (2DD)	F, E series (2HD)	Applicable command
Resolution	0.1 mm/pulse	0.05 mm/pulse	
Low-speed conversion	2 types (400 and 1,200 revolutions)	4 types (400, 600, 800 and 1,200 revolutions)	[668] L [669] L
Split function during embroidering	Not available	Available	[220] L [230] L
Needle down stop for split	Not available	Available	[221] L [231] L
Expansion option output	Not available	Available	

Setting the floppy disk

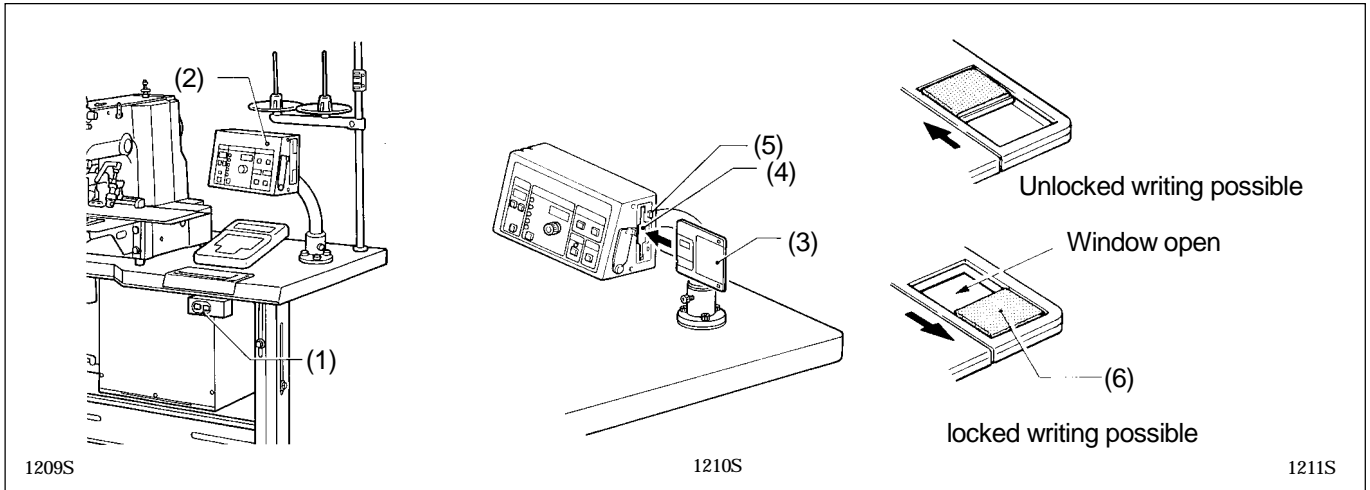

1. Turn on the power switch (1). The POWER indicator (2) will illuminate and the machine model number will appear on the display screen.
2. Hold the disk (3) with the label up and the shutter to the front, and insert the disk into the drive (4). It will click into place.
3. To eject the disk, press the eject button (5).

Note

- Slide the write protector (6) on the back of the disk up (the window opens) to lock the disk and prevent accidental erasure of the disk contents.
- Inserting the disk into the drive upside down or backwards may damage the drive and will prevent reading or writing of data.
- Be sure to store your disks away from any magnets or magnetic sources, including radios, televisions, telephones, and other devices. Magnetism can erase or damage disk contents. Also, be careful to prevent exposure of the disk to oil or dust.
- Be sure to make a copy of the floppy disk containing sewing data and keep the master floppy disk.
- When the R / W operation is not in operation, eject the floppy disk from the floppy disk drive and keep it in a case for floppy disk only to prevent exposure of the disk to dust.
- When the "E.4F" error (Reading error of sewing data) occurs very often;

1. Clean the floppy disk drive using the cleaning disk.
2. Read the sewing data. If the "E.4F" error occurs again, the floppy disk may be damaged. In this case, clean the floppy disk drive with the cleaning disk again.
3. Read the sewing data from the master floppy disk and write it in a new floppy disk. Do not use any damaged floppy disks again.

How to use the cleaning disk

1. Insert the cleaning disk into the floppy disk drive.
2. Select a program number (0-9), and press the "R/W" switch. If you select the same program number for cleaning every time, the same location of the cleaning disk is used and the lifetime of the cleaning disk will become short. Next time you clean it, select a different number.
3. After the cleaning is completed, the "E.4F" error appears. The error appears because the cleaning disk has no data. This is normal.
4. Cancel the error and eject the cleaning disk.

6-3. Using the program R/W (Read/Write) switch

Programmed stitch patterns stored on floppy disk can be read into memory, and newly programmed patterns can be written to disk for permanent storage and later recall.

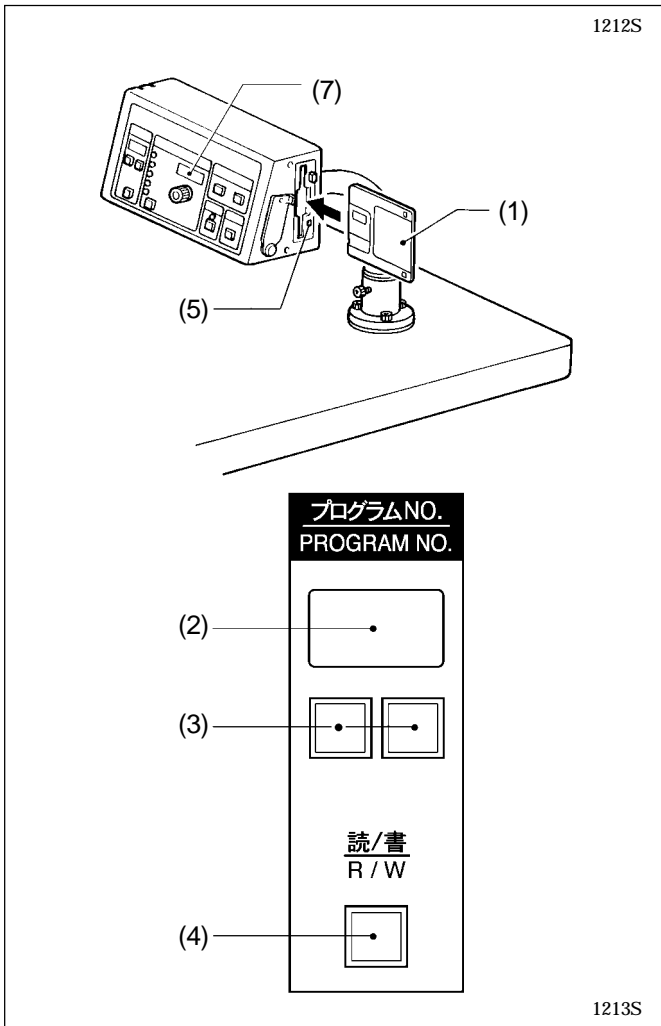

Insert the floppy disk (1) containing or which is to contain the programmed stitch pattern.

To READ a pattern to memory

Press the program select switch (3) on the operation panel. The program number will then appear in the PROGRAM NO. display (2). After selecting the desired program number, press the R/W switch (4). The disk drive indicator (5) will illuminate and a "P" will appear on the PROGRAM NO. display (2) to indicate that the data is being read. When the alarm sounds and the disk drive indicator (5) turns off, the program number will then flash in the PROGRAM NO. display (2) instead of the "P" to indicate that the reading of the data is complete.

To WRITE a pattern to disk

Press the program select switch (3) on the operation panel to select the desired program number. After programming the pattern using the stitch programmer, press the R/W switch (4). The disk drive indicator (5) will illuminate and a "P." will appear on the PROGRAM NO. display (2) to indicate that the data is being written. When the alarm sounds and the disk drive indicator (5) turns off, the program number will then flash in the PROGRAM NO. display (2) instead of the "P" to indicate that the writing of the data is complete.

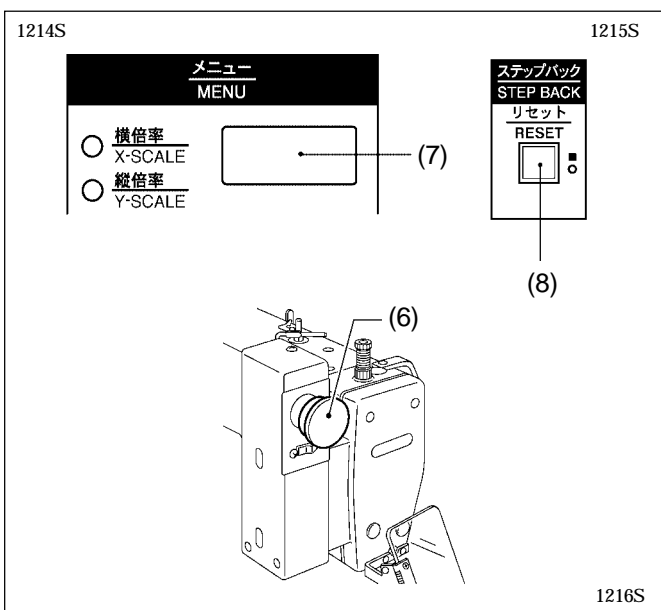

If an error message is displayed

If an error message code is displayed in the display (7), and alarm will sound.

Press the emergency stop switch (6) on the front of the machine to stop sewing machine operation, and then refer to and follow the error code list on page 63.

Clearing the error

1. Turn the EMERGENCY STOP switch (6) clockwise and then pull it forward to release it.
2. Press the STEP BACK (RESET) switch (8) on the operation panel (when memory switch No. 0d is ON).

If memory switch No. 0d is OFF, press the EMERGENCY STOP switch (7) once more to release it.

6-4. Using the TEST switch (Checking the sewing pattern)

Use the TEST switch to begin sewing again from any desired point when the thread breaks or the bobbin thread runs out.

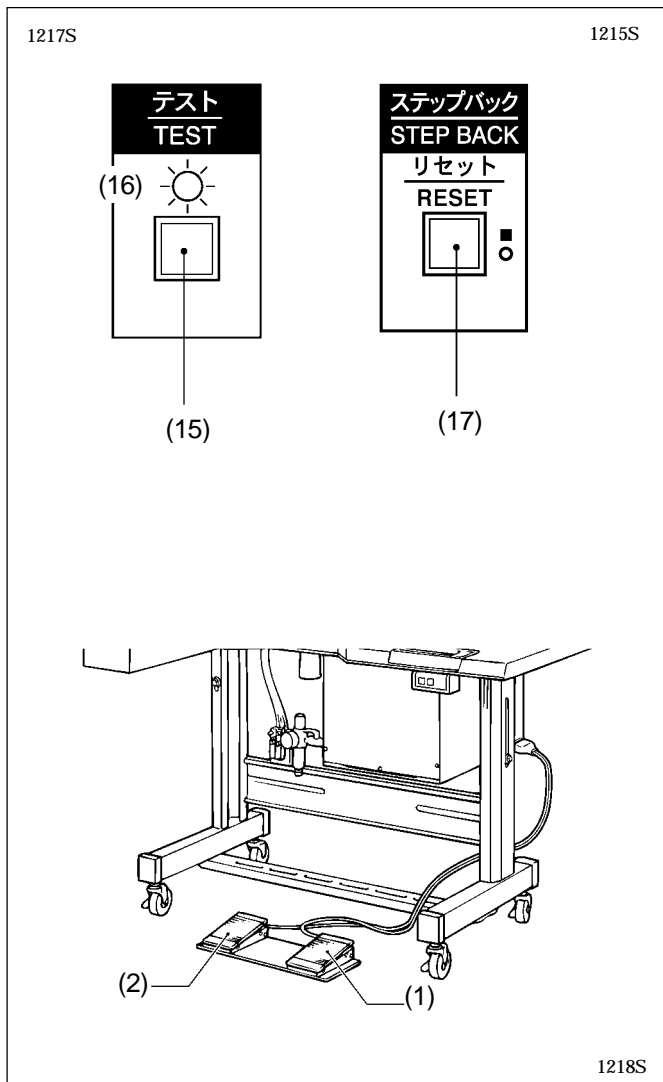

1. Press the TEST switch (15). The indicator (16) will light.
2. If the work clamp is raised, depress the work clamp lifter pedal (2) to lower the work clamp.
3. Press the starting pedal (1).

Note

After the feed mechanism has returned to the home position, it will then move the sewing start position and the program number will stop flashing.

This only occurs the first time that a program is selected.

4. Press the starting pedal (1). (The needle will remain stationary as the work clamp advances through the pattern at low speed one stitch at a time. Press the presser lifter pedal (2) to fast forward.
 - If the STEP BACK switch (17) is pressed while moving at low speed when memory switch No. 20 is ON, the work clamp will move in the forward direction in steps of 100 stitches.
5. When the work clamp reaches the desired position, press the TEST switch (15). The work clamp will stop, and the test indicator (16) will go out. If the work clamp was stopped too early, press the TEST switch (15) again to proceed.
 - If the work clamp was stopped too late, press the STEP BACK switch (17) to advance the work clamp one stitch at a time.

Resuming operation from a stopping point

6. Sewing will start when the starting pedal (1) is pressed.

6-5. Using the emergency stop switch

Press the emergency stop switch to immediately stop the sewing machine during actual sewing or when in the test mode.

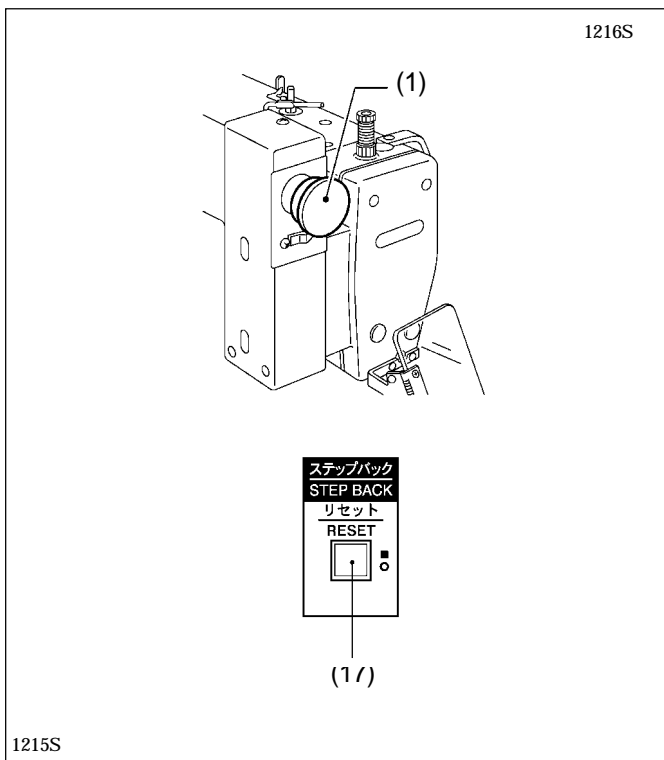

Clearing the error

1. Turn the EMERGENCY STOP switch (1) clockwise and then pull it forward to release it .
2. Press the STEP BACK (RESET) switch (17) on the operation panel. (The buzzer will stop sounding.)
3. If you do not wish to resume sewing, press the EMERGENCY STOP switch (1) once more to release it, and then press the STEP BACK (RESET) switch (17) so that the operation panel display flashes. The sewing machine will then be ready for the next sewing operation.

* If memory sewing No. 0d is OFF, press the EMERGENCY STOP switch (7) once more to release it.

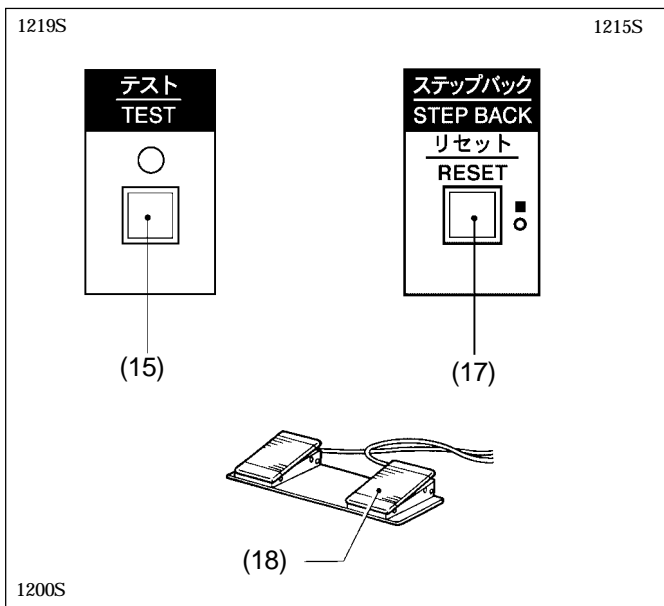

Continuing sewing from a stopping point

If you press the EMERGENCY STOP switch after the thread breaks or the bobbin thread runs out during sewing, you can then resume swing from the point where the thread broke or ran out.

1. Press the EMERGENCY STOP switch to release it.
2. Press the STEP BACK (RESET) switch (17) to trim the thread.
3. Press the STEP BACK (RESET) switch (17) once more.

(The sewing machine will move stitch by stitch in the reverse direction while this switch is pressed.)

If the sewing machine moves back too far, press the TEST switch (15) to move it forward again. Press the TEST switch (15) again to stop the machine.

4. After you have reached the desired position, depress the starting pedal to start sewing.

6-6. Adjusting the sewing SPEED control

The sewing speed can be changed in steps of 100 rpm to the appropriate speeds for each stitch length setting.

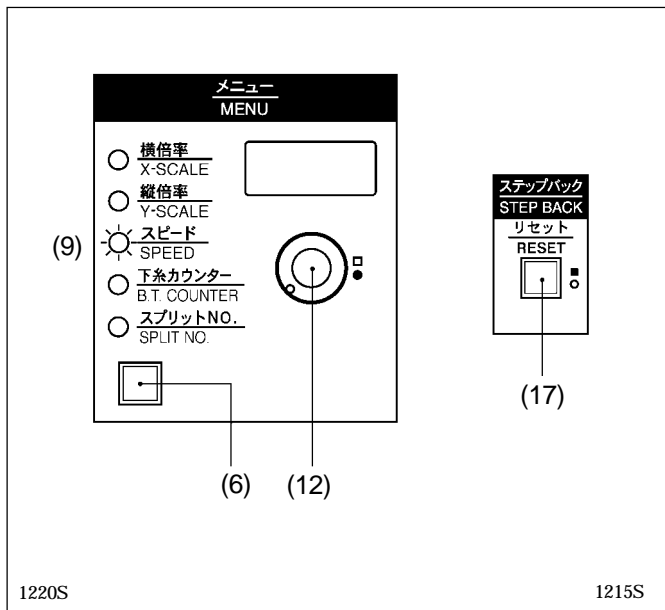

1. Press the MENU switch (6) until the SPEED indicator (9) illuminates.
2. While pressing the STEP BACK switch (17), turn the dial (12) until the desired speed is displayed.
 - The display will change in steps of 10 rpm.

6-7. Changing the X-SCALE and Y-SCALE settings

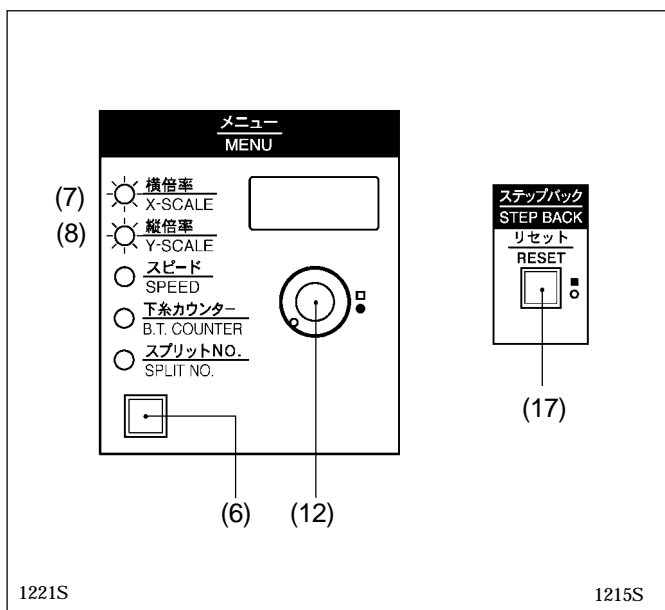

1. Press the MENU switch (6) until the X-SCALE indicator (7) or the Y-SCALE indicator (8) illuminates.
2. While pressing the STEP BACK switch (17), turn the dial (12) until the desired ratio flashes on the display.
 - The scale setting is displayed as a percentage.
3. The program number will flash, and after the home position is detected the flashing will stop.

6-8. Using the bobbin thread counter

Set the bobbin thread counter to display the number of pieces of the selected pattern which can be sewn with the amount of thread on the bobbin to avoid running out of bobbin thread in the middle of a pattern.

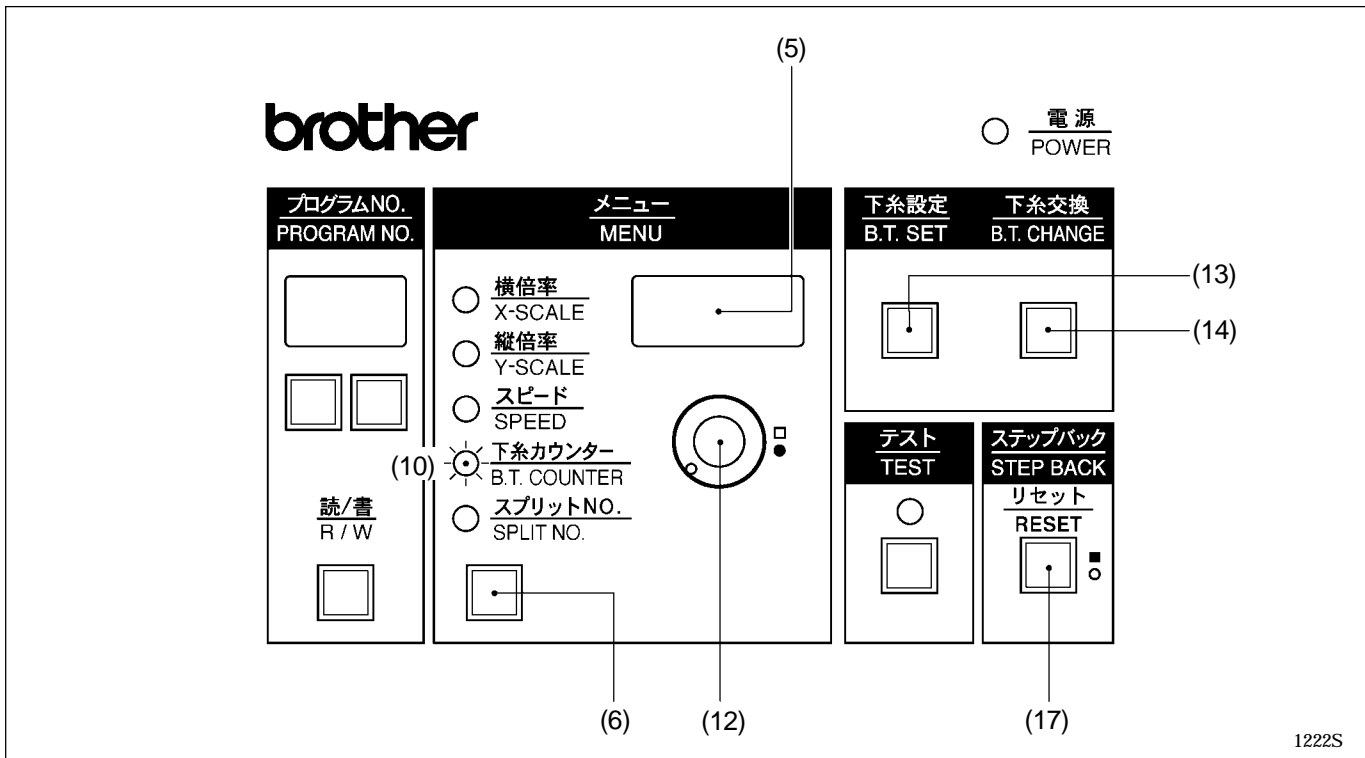

- Press the MENU switch (6) until the B.T. COUNTER indicator (10) illuminates.
 - The bobbin thread counter can be set to any number from <001> to <999>. If the counter is set to <000>, sewing continues irrespective of the amount of bobbin thread remaining.
- While pressing the STEP BACK switch (17), turn the dial (12) to set the number of articles to be embroidered.
- Insert the floppy disk and press the bobbin thread SET switch (13). An alarm will beep twice. This will record the number of work pieces shown in the counter (5) to the disk.
- The number shown in the counter (5) will decrease one each time the stitch pattern is completed. When the number of patterns shown in the counter is sewn, the counter (5) will red <000>, and an alarm will sound. (The sewing machine will not start even if the start switch is pressed.)
- Press the bobbin thread change switch (14) and replace the bobbin. The alarm will stop, and the number of work pieces set in step 3 will be displayed again in the counter (5).

1222S

6-9. Using production counter

Both PRO. NO. and B.T. COUNTER displays are available for the five-digit PRODUCTION counter.

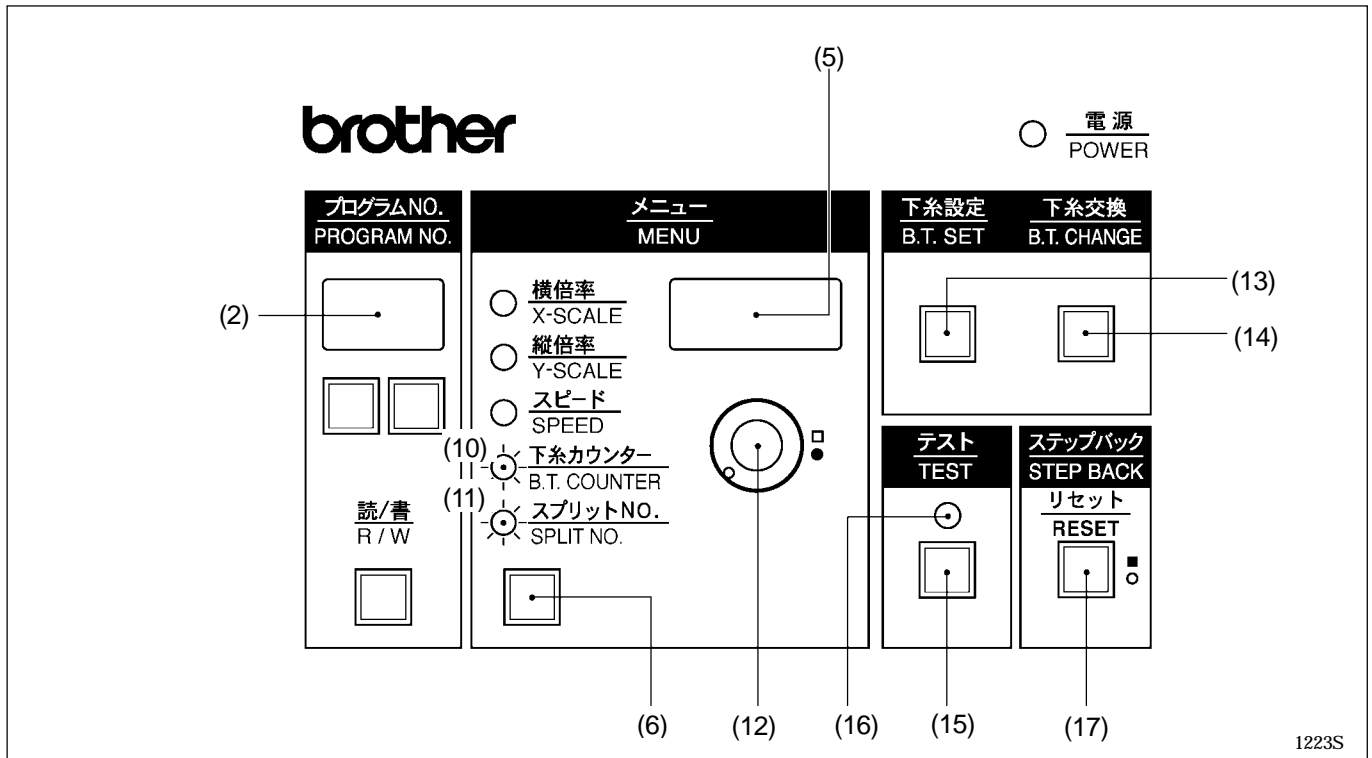

- While pressing the TEST switch (15), press the B.T. SET switch (13). The B.T. COUNTER indicator (10) and the SPLIT NO. indicator (11) will both illuminate, and the production counter value will appear on the program number display (2) and on the display screen (5).
 - Press the B.T. CHANGE switch (14). The PRODUCTION counter will display <00000>.
 - The production counter can be set to a value between <00000> and <99999> by turning the dial (12) while pressing the STEP BACK switch (17).
- Depress the start switch to start embroidering.
- Press the TEST switch (15) or the MENU switch (6). The TEST indicator (16) will switch off and the contents of each display screen will return to the normal display.

6-10. Using single split mode

By using single split mode, it is possible to change up to 100 patterns immediately.

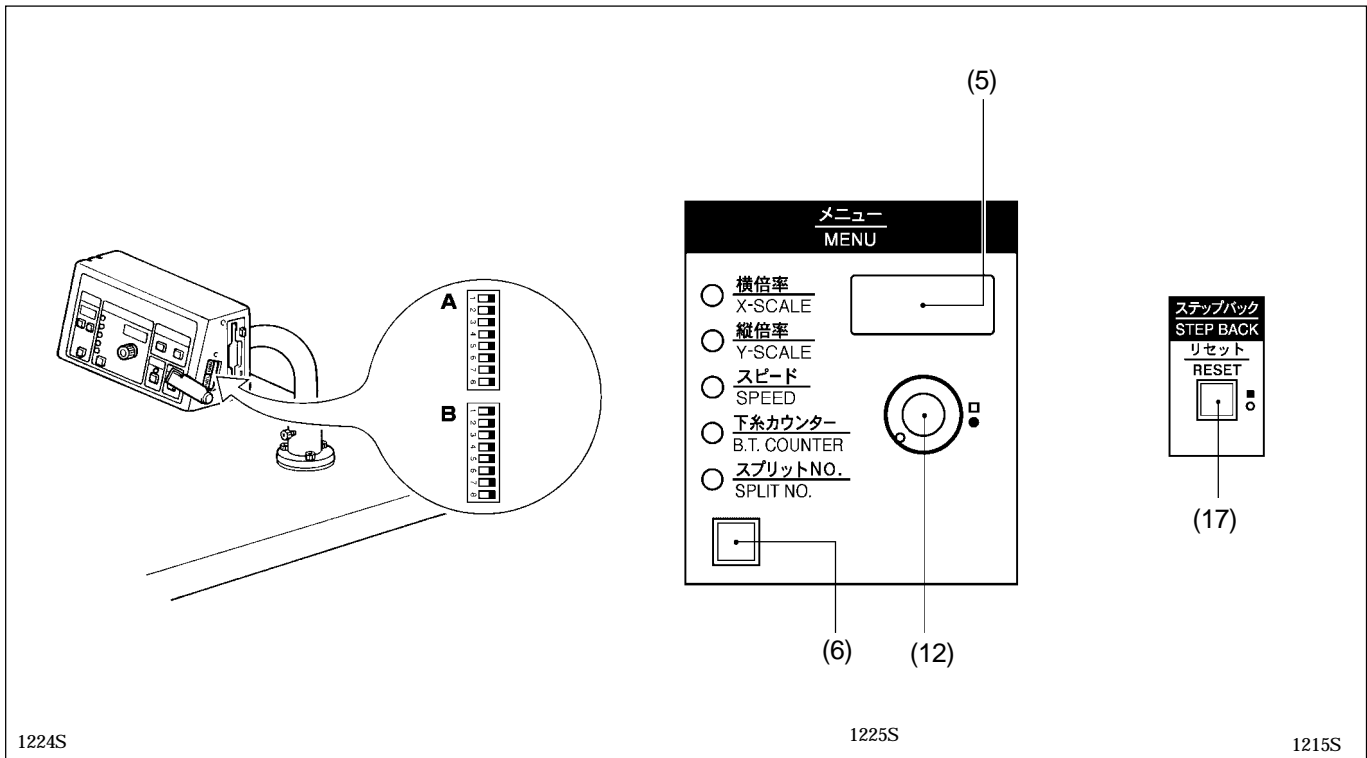

1. Move DIP switch B No. 1 to the ON position. This will activate single split mode.
(Refer to "10.DIP SWITCH".)
2. Turn on the power read in the patterns which have been programmed for split sewing.
3. Press the MENU switch (6) until the SPLIT NO. indicator (11) is illuminated. "1" will then appear in the display screen (5). Then, while pressing the STEP BACK switch (17), turn the dial (12) to change the contents appearing on the display screen (5) in order.
(Example) If three patterns have been programmed for split sewing, the number on the display screen changes in the following order: "1" → "2" → "3" → "1" → "2" ...
4. When the starting switch is pressed, only the pattern displayed on the display screen (5) will be sewn.

Note

As to split sewing, refer to the instruction manual of the "electronic programmable pattern tacker programmer".

6-11. Shifting a stitch pattern

- Programs which have already been programmed can be moved up, down and to the left and right.
(However, such patterns will be reset if the power supply is turned off or the program number is changed.)
- The feed position can be set to the any position desired.

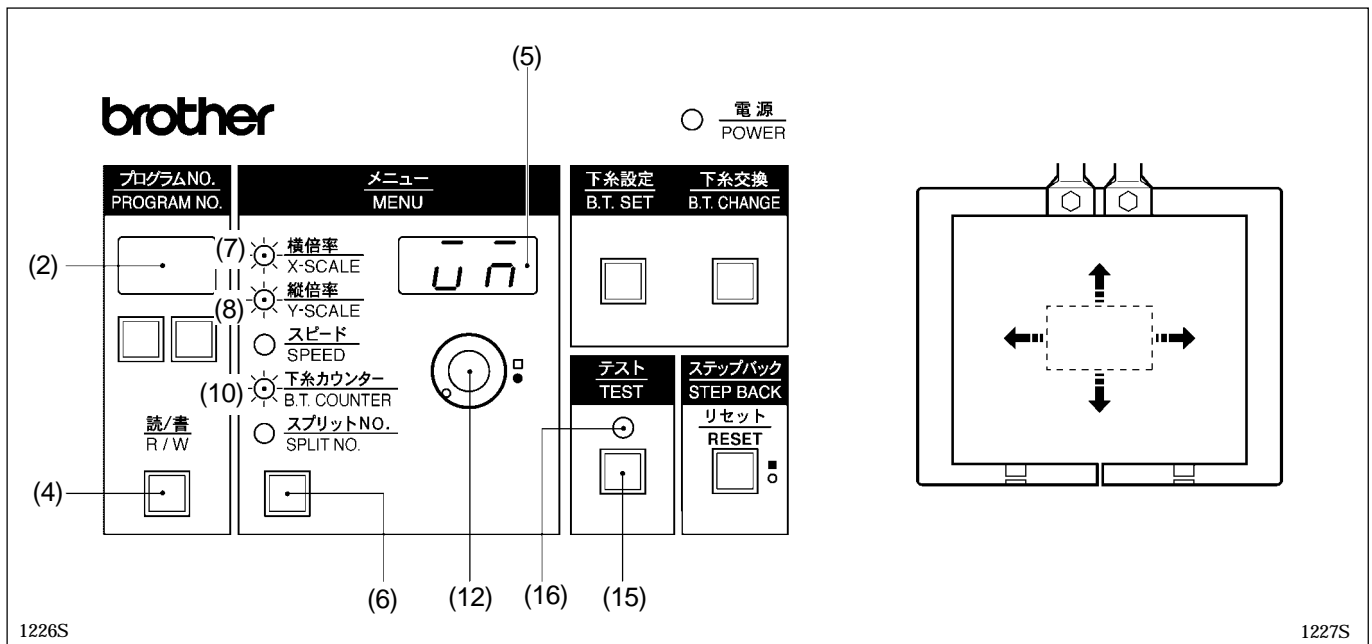

1. After the program data has been read, depress the start switch to move the feed mechanism to the sewing start position. If you carry out the following procedure while the program number display (2) is flashing (if the start switch has not been depressed) → (The feed position can be set to any position, but it will not be possible to move the stitch pattern.
2. Press the MENU switch (6) until the B.T. COUNTER indicator (10) illuminates.
3. Press and hold the TEST switch (15) and press the R/W switch (4). The test indicator (16) will light, and $\overline{U} \overline{7}$ will appear in the counter (5).
4. Press the MENU switch (6) so that either the X-SCALE indicator (7) or Y-SCALE indicator (8) illuminates.
5. Turn the setting dial (12) to move the feed mechanism one pulse at a time.
 - If the setting dial is turned counterclockwise while the X-SCALE indicator is illuminated, the feed mechanism will move to the right.
 - If the setting dial is turned clockwise while the X-SCALE indicator is illuminated, the feed mechanism will move to the left.
 - If the setting dial is turned counterclockwise while the Y-SCALE indicator is illuminated, the feed mechanism will move up.
 - If the setting dial is turned clockwise while the Y-SCALE indicator is illuminated, the feed mechanism will move down.
6. When the TEST switch (15) is pressed after the above fine adjustments have been made, the TEST indicator (16) and display window (5) will both switch off and movement of the stitch pattern will be completed.

Note

When moving the stitch pattern, the sewing start position can be moved to any desired point within the sewing area, but if the pattern goes outside the sewing area, an error will occur during sewing and you will not be able to sew the pattern. Give consideration to the pattern as a whole when moving it.

7. SEWING

 CAUTION



Turn off the power switch at the following times, otherwise the machine may operate if the foot switch is depressed by mistake, which could result in injury.

- When replacing the bobbin and needle
- When not using the machine and when leaving the machine unattended

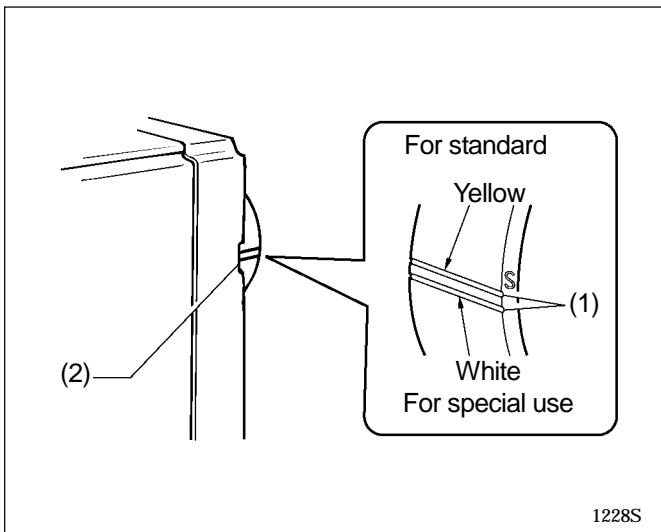

Do not touch any of the moving parts or press any objects against the machine while sewing, as this may result in personal injury or damage to be machine.

7-1. Before starting sewing...



Check that the needle bar is at its highest position.
Turn the machine pulley so that the index mark (1) on the pulley is between the marks (2) on the belt cover.

- * If the machine is started while the index mark (1) is not between these two marks (2), error message "E-22" will be displayed.
(only when memory switch No.14 is on)

7-2. Sewing operation

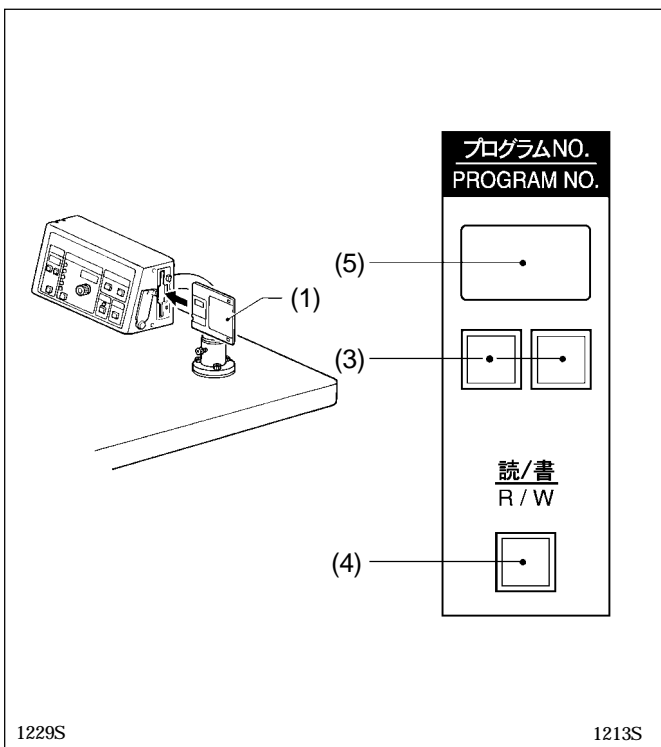

1. Turn the power switch (1) on.
(The power indicator on the operation panel will light.)
2. Insert the floppy disk (2).
3. Press the PRO. No. selection switch (3) to select the desired program number.
4. Press R/W switch (4).
 - The floppy disk drive indicator will light and the PROGRAM NO. display (5) will show a "P" while the data is being read. When reading is completed, an alarm will sound and the indicator will go out, then the PROGRAM NO. display (5) will blink the program number.

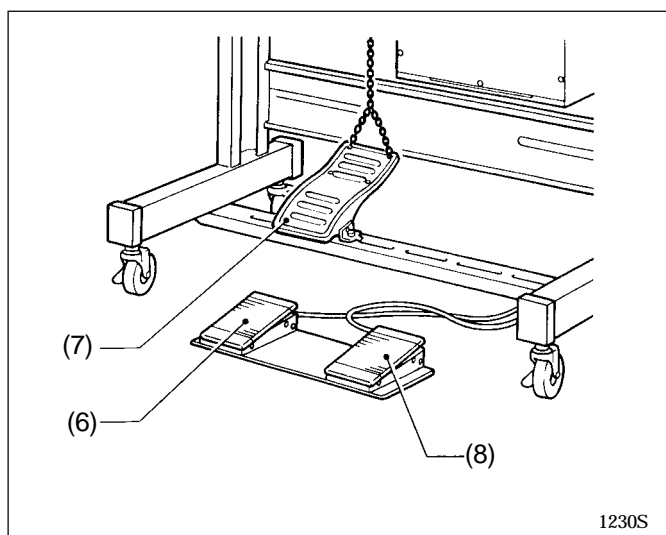

5. Step on the presser lifter switch (6) to raise the presser foot.
6. Insert the work piece under the work clamp, and press the presser lifter switch (6) to lower the clamp.
 - This is convenient when sewing while sitting.
 - When working with small pieces which are hard to position, or when precise sewing is required, press the manual work clamp lifter pedal (7) for precise positioning of the work piece, and then press presser lifter switch (6).
7. Press the starting pedal (8).

Note

The work clamp will return to the origin, and will then advance to the sewing start position and blinking will stop. This is only required the first time a program is sewing.

8. Press the starting pedal (8) again to start sewing.
9. After sewing is completed, the thread cutter will automatically operate, then the work clamp will rise.

Note

When the power is turned on after once being turned off, the same pattern of sewing can be continued since the machine will stores the sewing data from the last time.

8. CLEANING AND INSPECTION

⚠ CAUTION



Turn off the power switch before carrying out cleaning, otherwise the machine may operate if the foot switch is pressed by mistake, which could result in injury.



Be sure to wear protective goggles and gloves when handling the lubricating oil and grease, so that they do not get into your eyes or onto your skin, otherwise inflammation can result.

Furthermore, do not drink the oil or eat the grease under any circumstances, as they can cause vomiting and diarrhoea. Keep the oil out of the reach of children.



Wait until the motor has cooled down before cleaning the air holes.

The motor may be hot immediately after it has been used, and it may cause burns if touched.

8-1. Cleaning the rotary hook

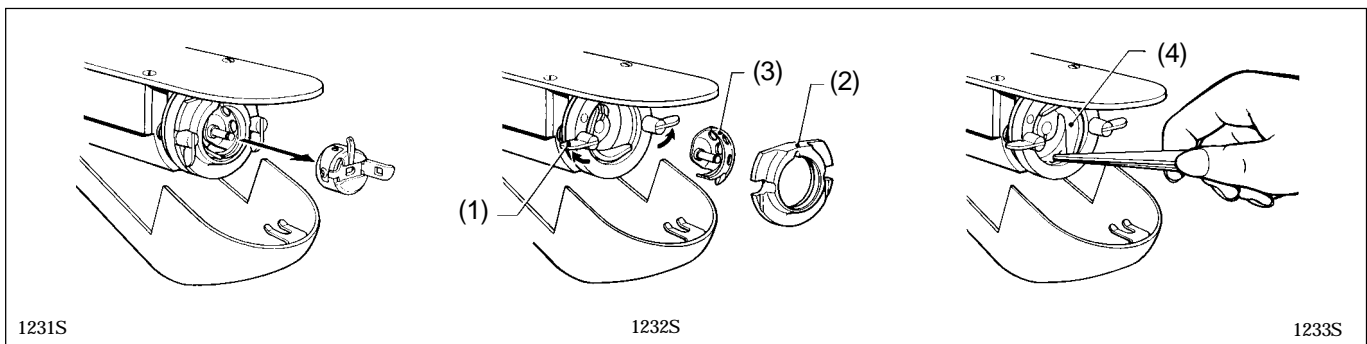

1. Pull the shuttle hook cover forward to open, and then remove the bobbin case.
2. Open the large shuttle hook set claw (1) in the direction indicated by the arrow, and then remove the large shuttle hook (2) and the inner rotary hook (3).
3. Clean all the dust and thread ends from around the driver (4), the top of the rotary hook thread guide and the shuttle race.

8-2. Lubrication

Note 1: Fill the machine with oil when the oil level is down to about one-third full in the oil sight glass.

If oil is not added and the oil drops below this level, there is the danger that the machine may seize during operation.

Note 2: Be sure to let the machine operate for a while after adding the oil.

Note 3: If there is no more oil on the felt of the shuttle race base, problems with sewing may result, so add oil to the felt until it is slightly soaked.

Note 4: Use only specified Brother oil (Nisseki Mitsubishi Sewing Lube 10N; VG10) for the machine oil.

Lubrication points refer to "4. LUBRICATION".

8-3. Draining the oil

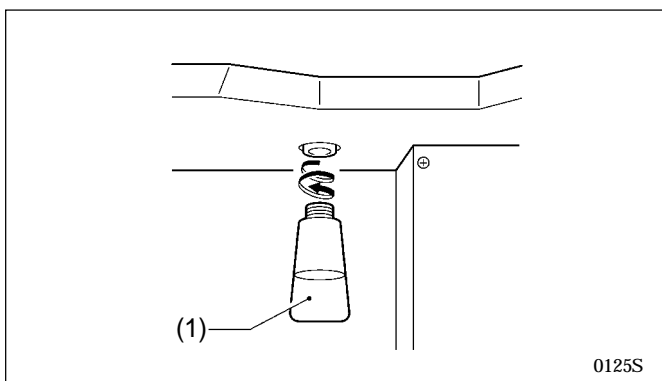

1. Remove and empty the waste oil container (1) whenever it is full.
2. After emptying the waste oil container (1), screw it back into its original position.

8-4. Cleaning the control box air inlet port

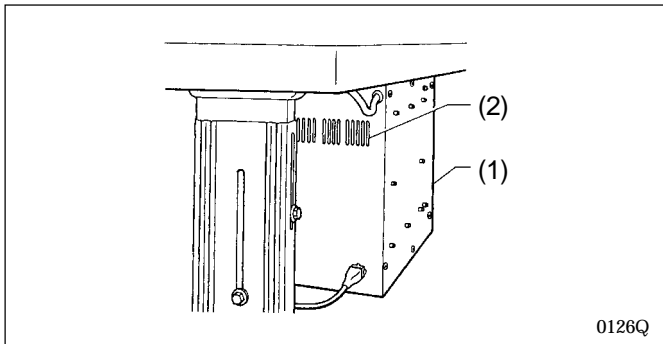

Use vacuum cleaner to clean the filter in the air inlet port (2) of the control box (1) at least once a month.

- * If the machine is used while the air inlet port is blocked, the inside of the control box will overheat. When this happens, the overheating error code ("E-d0") will be displayed and you will not be able to operate the sewing machine.

8-5. Cleaning the air holes of belt cover and frame side cover

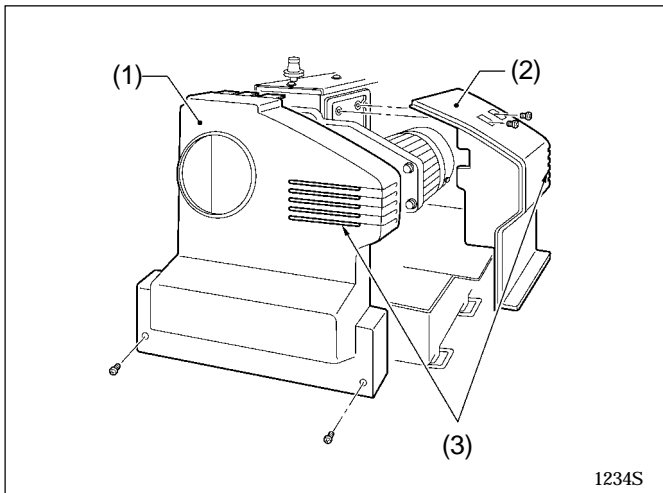

Remove the belt cover (1) and the frame side cover (2), and then clean the air holes (3).

After cleaning, install the belt cover (1) and the frame side cover (2).

- * If dust collects in the air holes, it may cause the motor to overheat. The air holes should be cleaned at regular intervals. In addition, be careful not to let any foreign matter get into the air holes.

8-6. Cleaning the eye guard

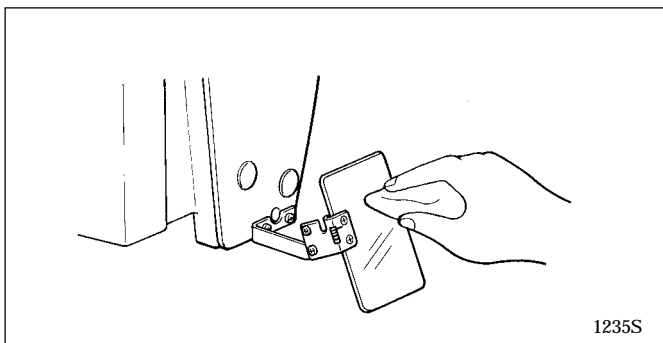

Wipe the eye guard clean with a soft cloth.

Note

Do not use solvents such as kerosene thinner to clean the eye guard.

8-7. Checking the needle

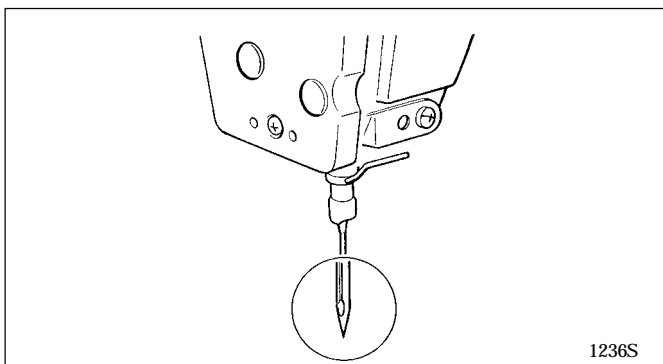

Always check that the tip of the needle is not broken before starting sewing.

9. STANDARD ADJUSTMENTS

⚠ CAUTION



Maintenance and inspection of the sewing machine should only be carried out by a qualified technician.



Ask your Brother dealer or a qualified electrician to carry out any maintenance and inspection of the electrical system.



Turn off the power switch and disconnect the power cord from the wall outlet at the following times, otherwise the machine may operate if the foot switch is depressed by mistake, which could result in injury.

- When carrying out inspection, adjustment and maintenance
- When replacing consumable parts such as the rotary hook and knife



Hold the machine head with both hands when tilting it back or returning it to its original position. Furthermore, after tilting back the machine head, do not push the face plate side or the pulley side from above, as this could cause the machine head to topple over, which may result in personal injury or damage to the machine.



If the power switch needs to be left on when carrying out some adjustment, be extremely careful to observe all safety precautions.



If any safety devices have been removed, be absolutely sure to re-install them to their original positions and check that they operate correctly before using the machine.

9-1. Adjusting the needle bar height

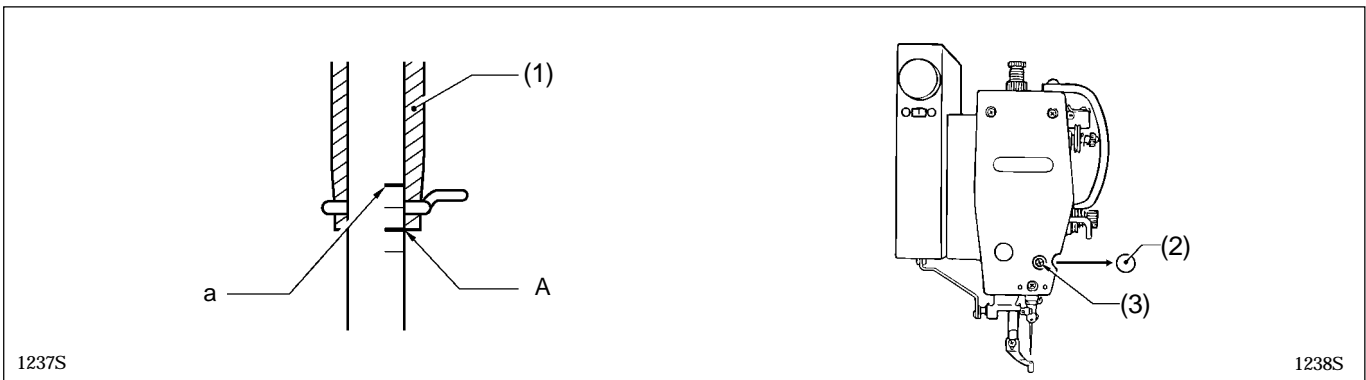

Turn the machine pulley to move the needle bar to the lowest position. Then remove the rubber plug (2), loosen the screw (3) and then move the needle bar up or down to adjust so that the second reference line from the bottom of the needle (reference line A) is aligned with the lower edge of the needle bar bush (1).

* If using a DP X 5 needle, use the highest reference line (reference line a).

9-2. Adjusting the needle bar lift amount

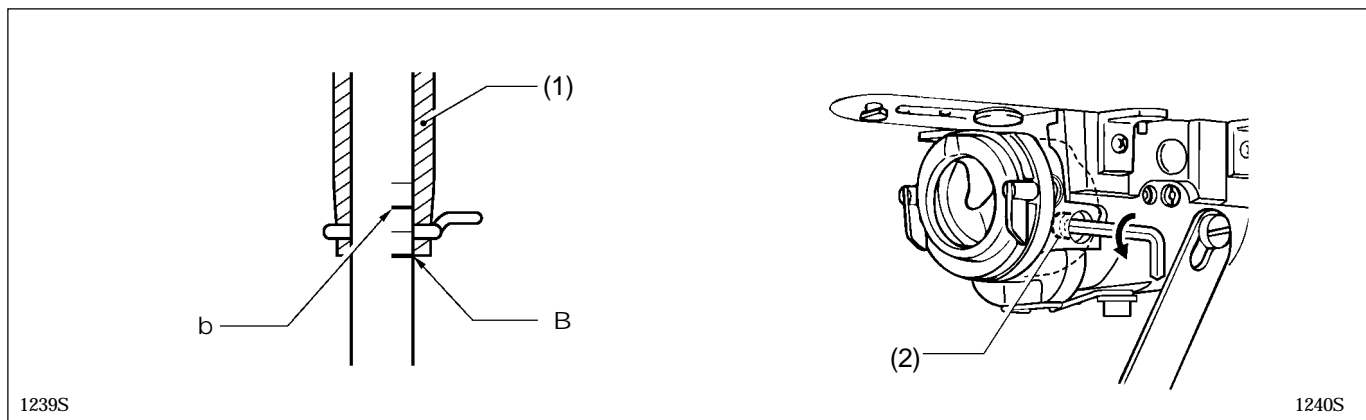

Turn the machine pulley to raise the needle bar from the lowest position until the lowest reference line on the needle (reference line B) is aligned with the lower edge of the needle bar bush (1). Then loosen the screw (2) and move the driver to adjust so that the tip of the rotary hook is aligned with the needle center line.

* If using a DP X 5 needle, use the second reference line from the top of the needle (reference line b).

9-3. Adjusting the needle clearance

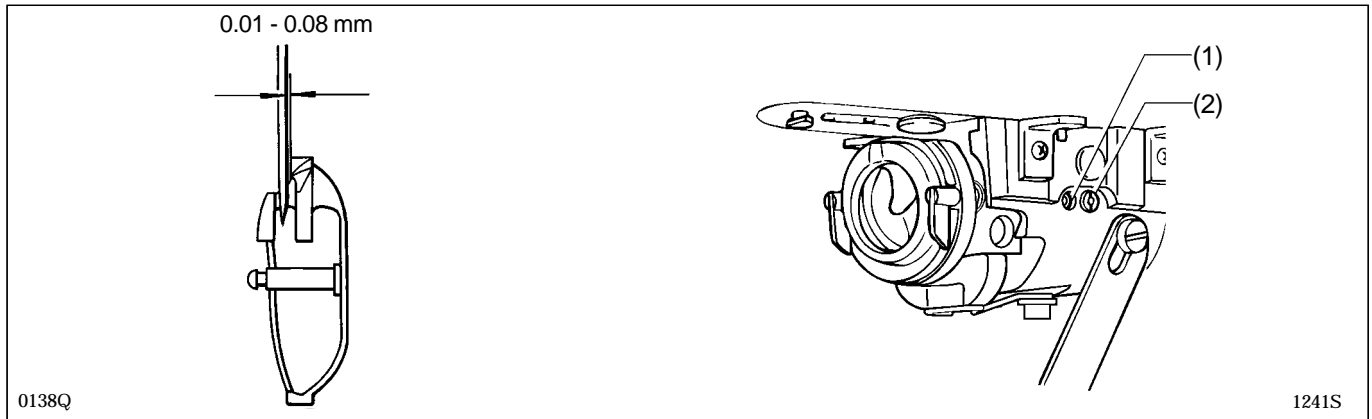

Turn the machine pulley to align the tip of the rotary hook with the needle center line. Then loosen the set screw (1) and turn the eccentric shaft (2) to adjust so that the clearance between the needle and the rotary hook is 0.01 - 0.08 mm.

9-4. Adjusting the driver needle guard

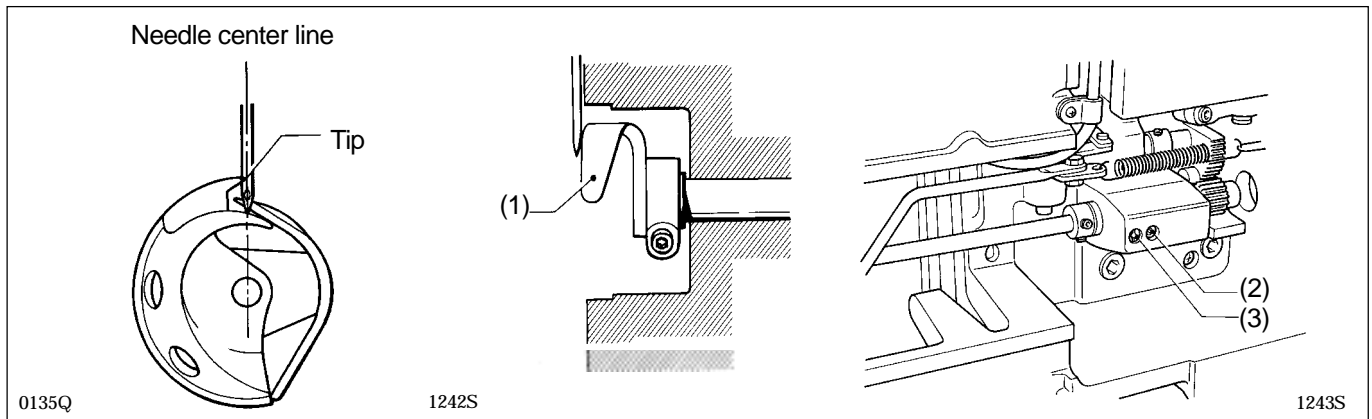

Turn the machine pulley to align the tip of the rotary hook with the needle center line. Then loosen the set screw (2) and turn the eccentric shaft (3) to adjust so that the driver needle guard (1) contacts the needle. If the needle contact pressure is too great, skipped stitches may occur. On the other hand, if the driver needle guard (1) is not touching the needle, the tip of the inner rotary hook will obstruct the needle, resulting in an excessively high amount of friction.

9-5. Adjusting the shuttle race thread guide

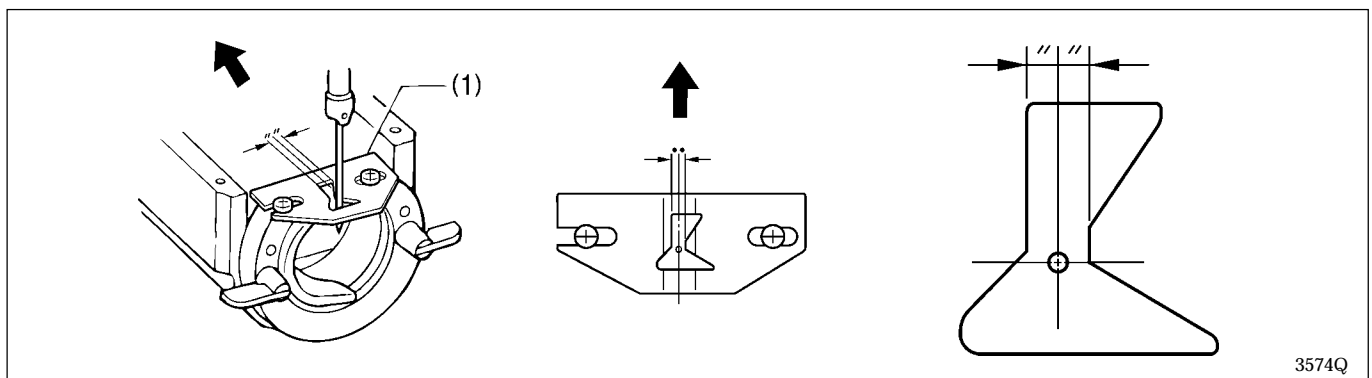

Install the shuttle race thread guide (1) by pushing it in the direction of the arrow so that the needle groove is aligned with the center of the needle plate hole.

Note

If the shuttle race thread guide is in the wrong position, thread breakages, soiled thread or catching of the thread may occur.

9-6. Adjusting the movable knife

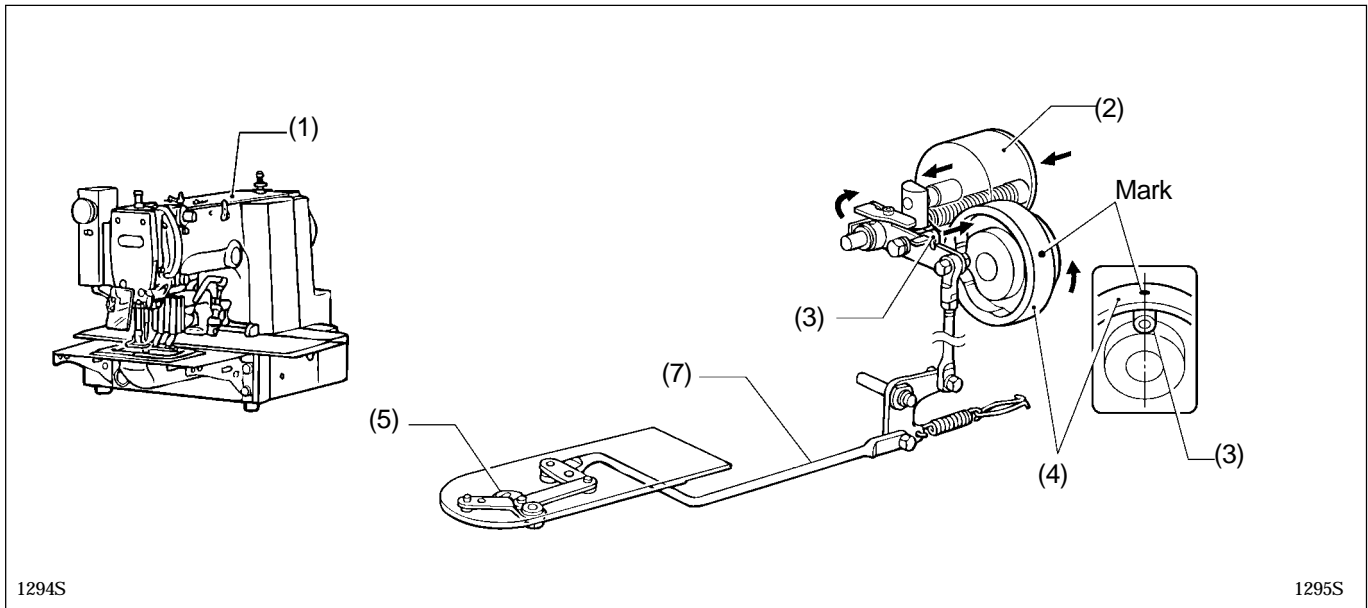

1. Remove the top cover (1) while making this adjustment.
2. Press down on the plunger (2) of the thread trimming solenoid as shown in the illustration, and fit the roller (3) into the groove of the thread trimmer cam (4).
3. In this condition, turn the machine pulley to align the position of the roller (3) with the mark on the thread trimmer cam (4).

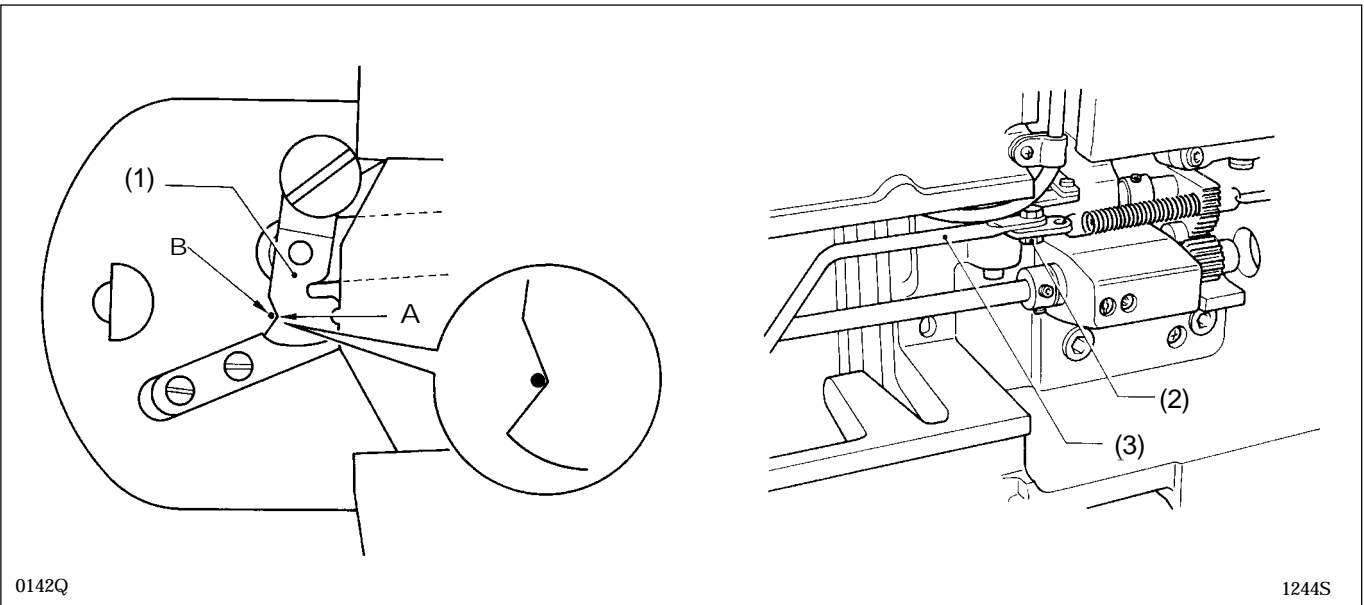

4. Loosen the nut (2) and move the connecting rod lever (3) to the left or right to adjust so that the V section A is aligned with the index mark B on the needle plate when in this condition (the procedure 3.) and the movable knife (1) is pushed to the machine pulley side so that there is no play.

<Replacing the movable and fixed knives>

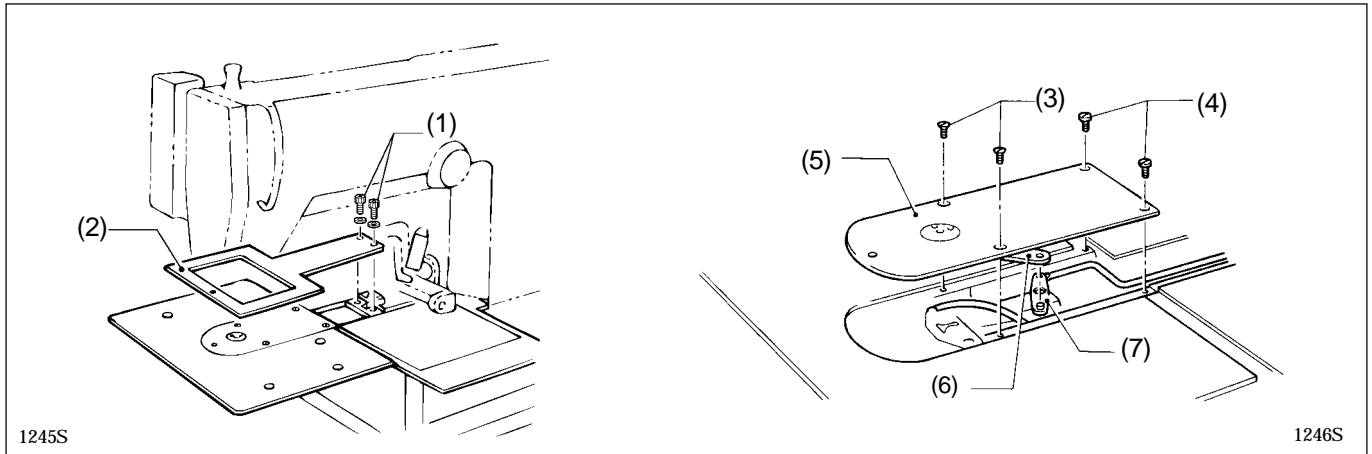

1. Remove screws (1), and remove feed plate (2). Remove screws (3) and (4), and remove needle plate (5). Now disconnect the thread cutter connecting rod (6) from stud (7).

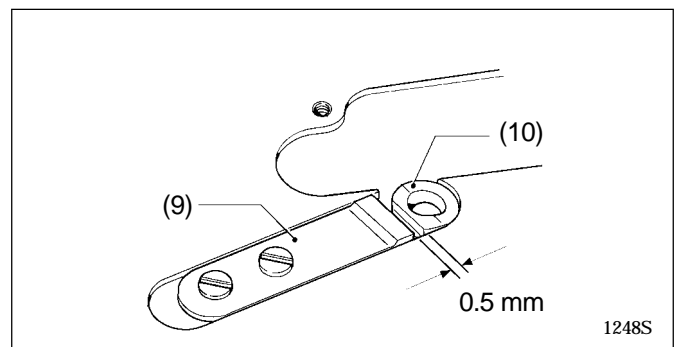
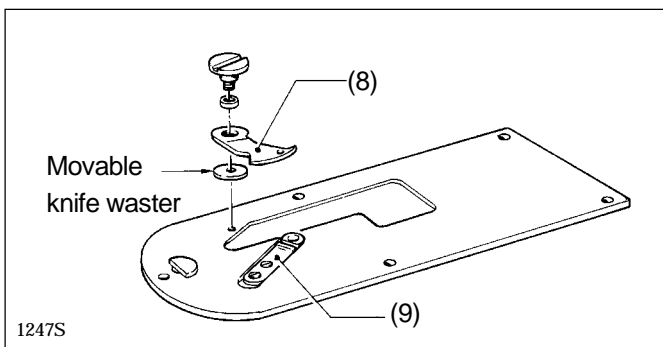

2. Remove the movable knife, and replace it with a new movable knife. Now check the cutting edge of the movable knife (8) and the fixed knife (9). If necessary, use the provided movable knife washer to adjust the knives so that they cut properly.

3. Install the fixed knife (9) 0.5 mm away from needle hole plate (10).

Adjusting the engagement of the movable knife and fixed knife

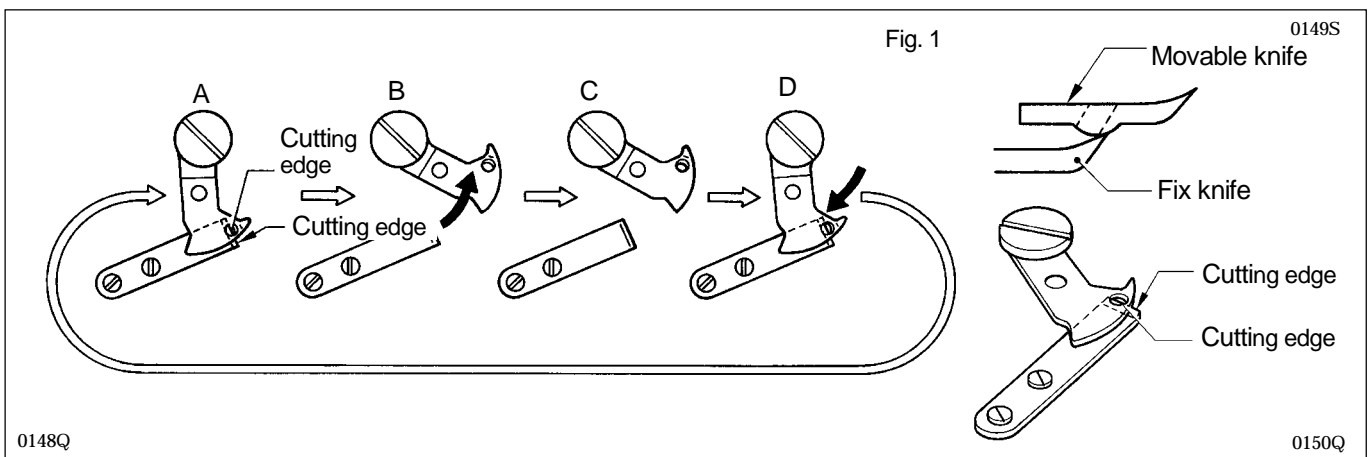

A. After the movable knife and fixed knife are properly engaged, tighten the screw as shown in Fig.1.
 B. Turn the movable knife (in the direction of the arrow) while the screw is still tightened.
 C. Loosen the screw.
 D. Turn the movable knife (in the direction of the arrow) while the screw is still loosened.
 Repeat above steps A, B, C and D four or five times to maintain the cutting performance of the knife.

9. STANDARD ADJUSTMENTS

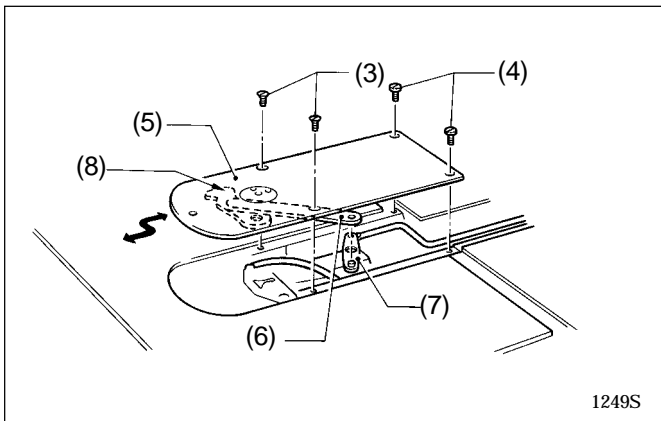

1249S

4. Fit the thread cutter connecting rod (6) on connecting lever pin (7), and install needle plate (5).
 - When fitting the connecting rod (6) on the connecting lever pin (7) and before tightening screws (3) and (4), move the needle plate back and forth a little bit to confirm that the movable knife (8) is pulled by the connecting rod (6).

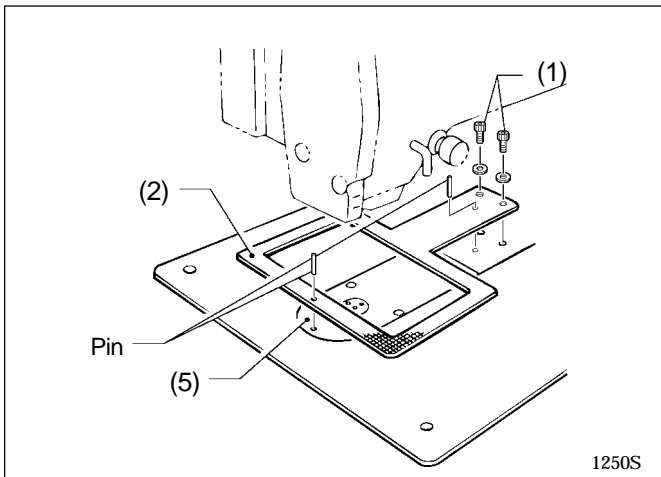

1250S

5. When installing the feed plate (2), use a 2 mm-diameter pin (such as a needle) to align the hole in the needle plate (5) with the hole in the feed plate (2) BAS-311F-0, -L → “when the machine is at the home position”, BAS-326F-0 → “when the sewing machine has moved 20 mm (400 pulses) backward (in the Y direction) from the home position” and then tighten the screws (1).

9-7. Adjusting the presser foot

Turn the pulley by hand to lower the presser foot to the down position, and then proceed with the steps below.

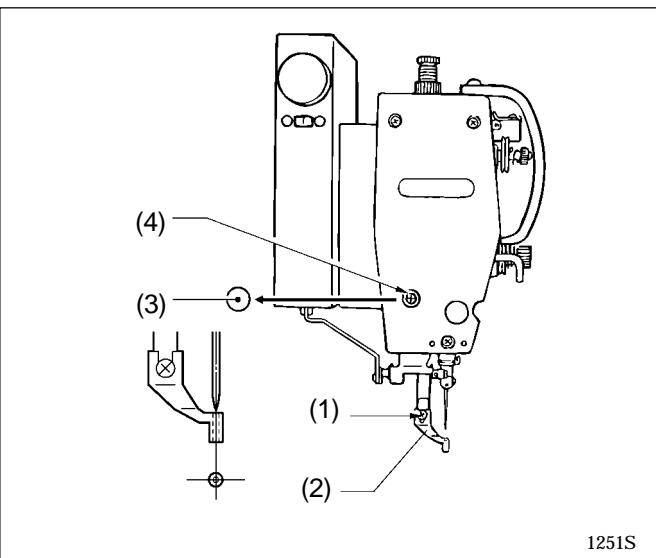

1251S

1. Loosen screw (1), set the bottom of the presser foot (2) lightly against the work piece, and then tighten screw (1).

Note

If the presser foot is lowered too far, the work piece will shift when sewing. Also, if the presser foot is too high, skipped stitches may occur.

2. Turn the pulley by hand, and make sure the needle enters the center of the needle hole in the presser foot (2). If the needle is not aligned with the center of the needle hole, remove cap (3), loosen screw (4), and turn the presser foot (presser bar) to adjust.



If the needle projects past the presser foot when the presser foot is raised, injury may result.

9-8. Changing the presser foot lift

<Standard presser foot lift is 3 mm (max. 8 mm). >

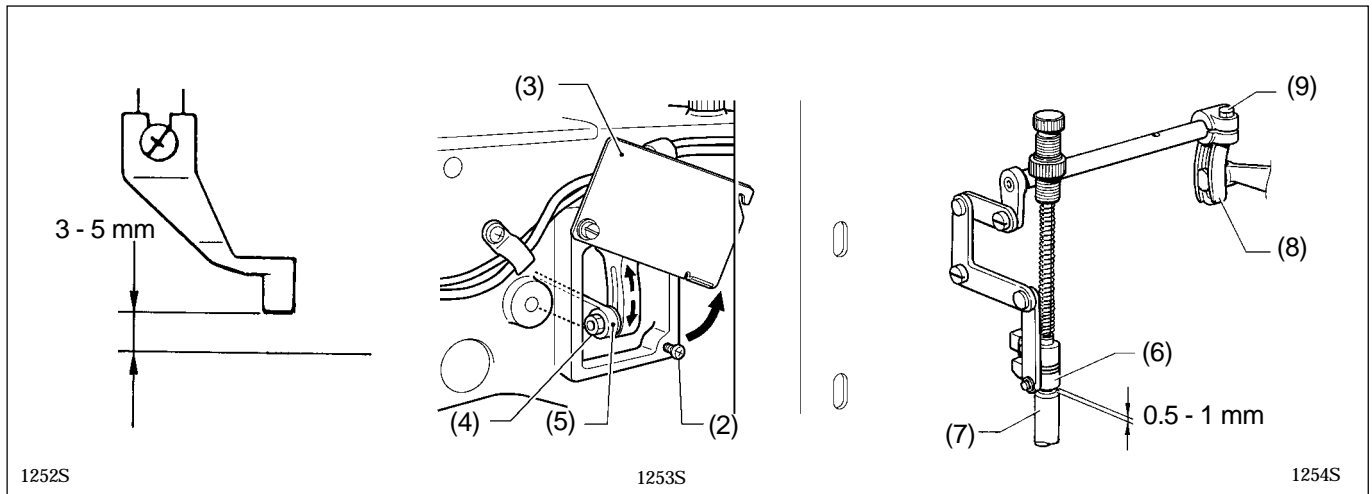

Adjusting presser foot lift to 3 - 5mm

1. Loosen the screw (2) and open the intermittent cover (3).
2. Loosen the nut (4) and adjust the intermittent presser connecting rod (5) position.
(When the intermittent presser connecting rod is raised, the lift will increase. When lowered, the lift will decrease.)

Adjusting presser foot lift to 5 - 8 mm

1. Turn the upper shaft to set the presser foot to its lowest point. Loosen the screw (9) of intermittent presser arm (R) (8).
Adjust the clearance between the presser lifter (6) and the presser bar bush (7) to 0.5 - 1 mm.
2. Loosen the nut (4) and adjust the intermittent presser connecting rod (5) position.
(When the intermittent presser connecting rod is raised, the lift will increase. When lowered, the lift will decrease.)

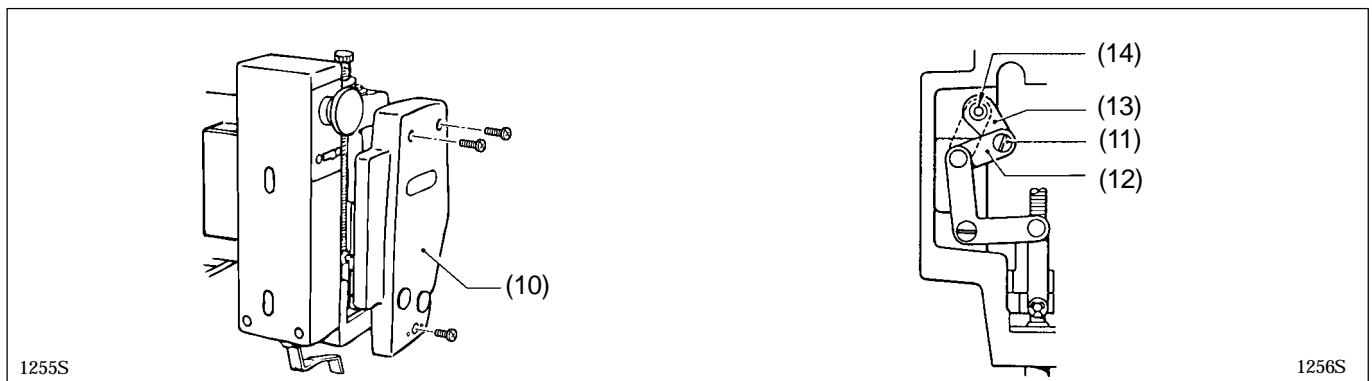

If vertical movement of the presser foot is not required

1. Remove the face plate (10).
2. Remove the stud screw (11) and re-attach the intermitte connecting rod (12) to the upper screw hole (14) of the intermittent presser arm F (13).

9-9. Adjusting the wiper

<For vertical wiper (standard)>

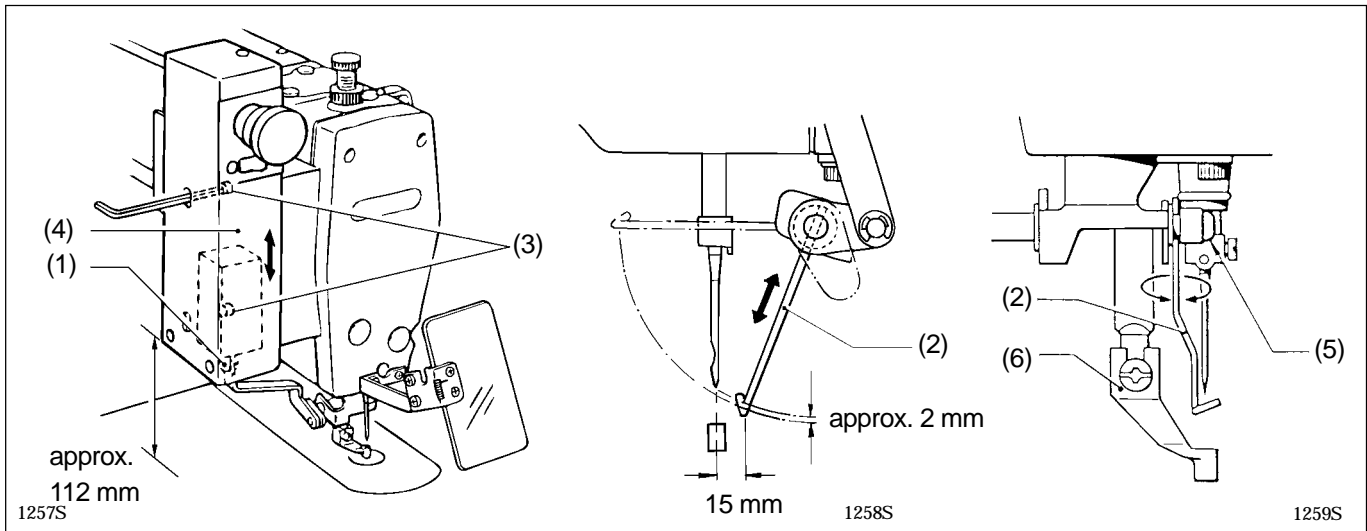

1. When the thread wiper solenoid plunger (1) is driven to the full stroke, the wiper (2) should be 15 mm in front of the needle center. Loosen screws (3) and shift the entire solenoid bracket (4) up or down to adjust. The standard height from the solenoid bracket (4) bottom to the needle plate top is approximately 112 mm.

2. When the wiper (2) is operated and aligned with the center of the needle bar, the distance from the wiper (2) to needle tip should be approximately 2 mm. Loosen screw (5) and move the wiper (2) in or out to adjust. As shown in Fig. A, make sure the wiper (2) does not strike the presser foot (6) or needle.

Note

Check that the wiper (2) is not touching the finger guard.

<For vertical wiper (standard)>

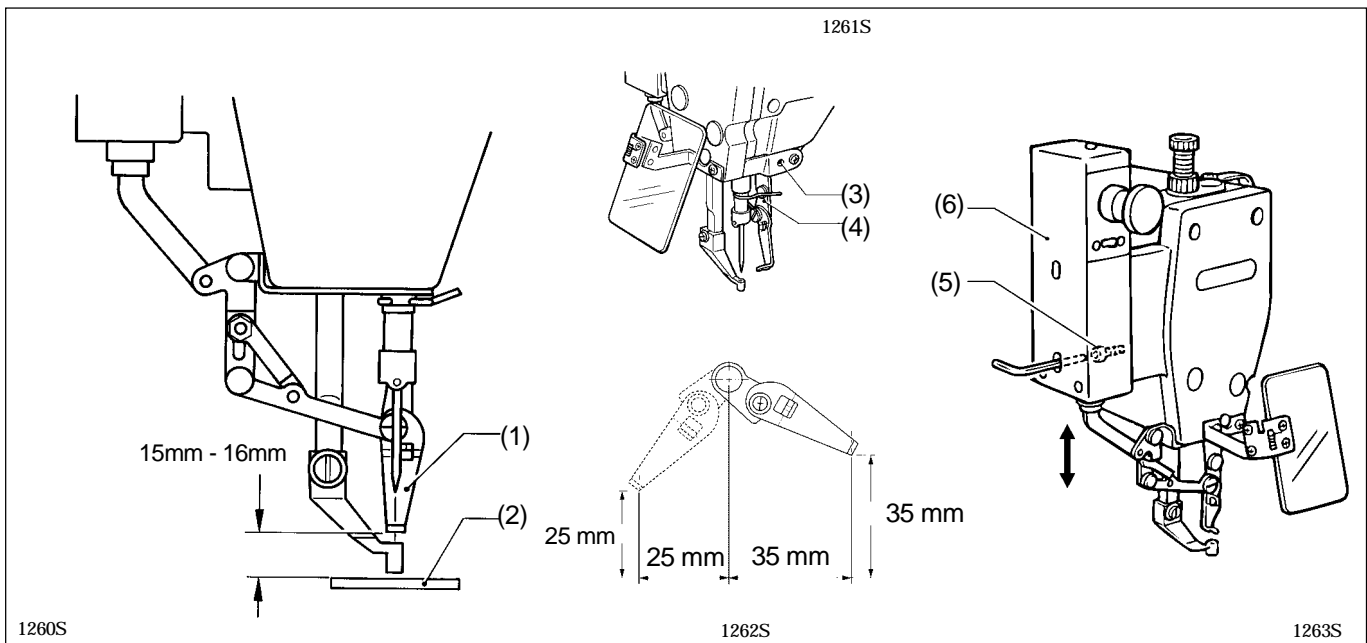

1. Loosen the set screw (2) and move the wiper arm support (3) up or down to adjust so that there is a clearance of 15 - 16 mm between the bottom of the thread wiper and the tip (1) of the needle when the thread wiper is aligned with the center of the needle bar.

2. After the thread wiper has wiped the thread, loosen the bolt (5) and move the whole solenoid fixing plate (6) up or down to adjust so that the distance is approximately 25 mm.

9-10. Adjusting the two-step work clamp lift amount

- The maximum work clamp lift amount is 17 ± 1 mm (for solenoid type) or 30 ± 1 mm (for pneumatic type) from the top of the needle plate.
- The lift amount for each model is adjusted as shown in the table at the time of shipment.

type	Solenoid type (BAS-311F-0 only)	Pneumatic type
Lift amount	17 mm	20 mm

9-10-1. BAS-311F-0 Solenoid type

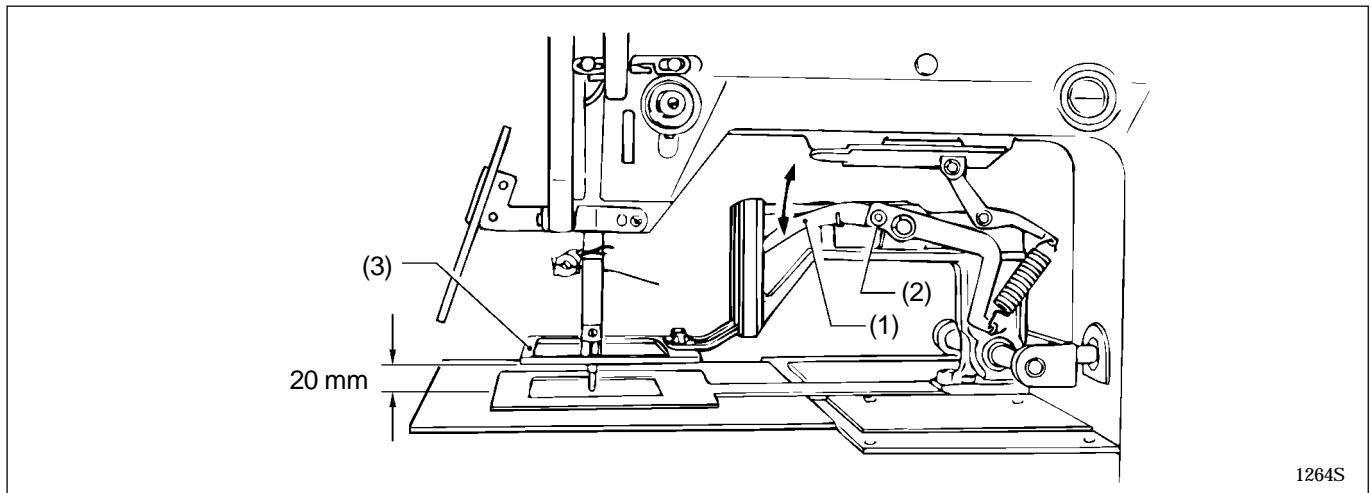

1. Turn the power switch OFF.
2. Loosen the bolts (2) of work clamp arm lever F (1) .
3. Place a scale against the work clamp (3), and then move work clamp arm lever F (1) up or down to adjust so that the amount of lift above the top of the needle plate is 17 mm.
4. After adjusting the lift amount (17 mm), tighten the bolts of work clamp arm lever F (1) .

9-10-2. BAS-311F-0, 311F-L Pneumatic type

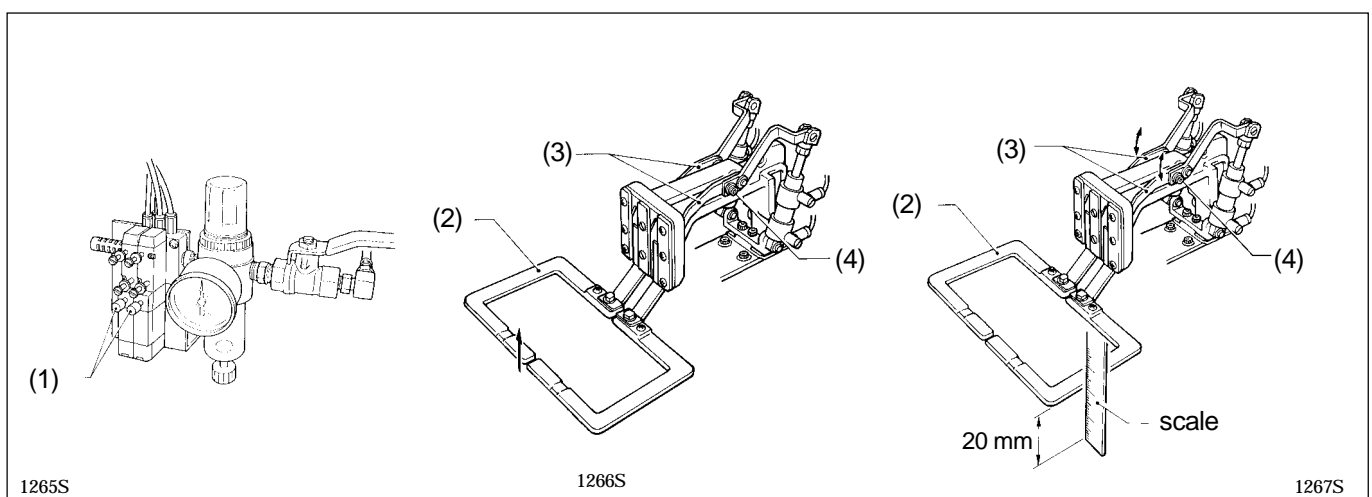

1. Turn on the air, and then press the work clamp lifter switch (1) to raise the work clamp (2) .
2. Loosen the bolts (4) of work clamp arm lever F (3) .
3. Place a scale against the work clamp (2), and then move work clamp arm lever F (3) up and down to adjust so that the lift amount is 20 mm.
4. After adjusting the lift amount (20 mm), tighten the bolts (4) of work clamp arm lever F (3).

9. STANDARD ADJUSTMENTS

9-10-3. BAS-326F-0

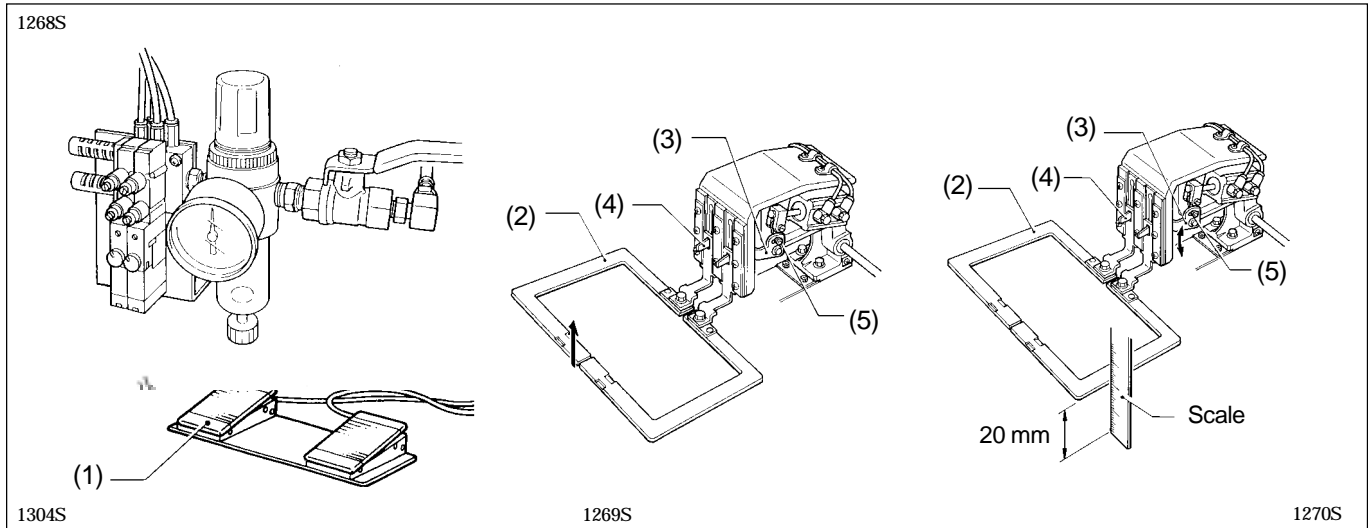

1. Turn on the air, and then press the presser lifter switch (1) to raise the presser foot (2) .
2. Loosen the bolts (5) of presser lifter lever UR (3) and presser lifter lever UL (4).
3. Place a scale against the presser foot (2), and then move presser lifter lever UR (3) and presser lifter lever UL (4) up and down to adjust so that the amount of presser lift is 20 mm from the top of the needle plate.
4. After adjusting the lift amount (20 mm), tighten the bolts (5) of presser lifter lever UR (3) and presser lifter lever UL (4).

9-10-4. Adjusting the air pressure

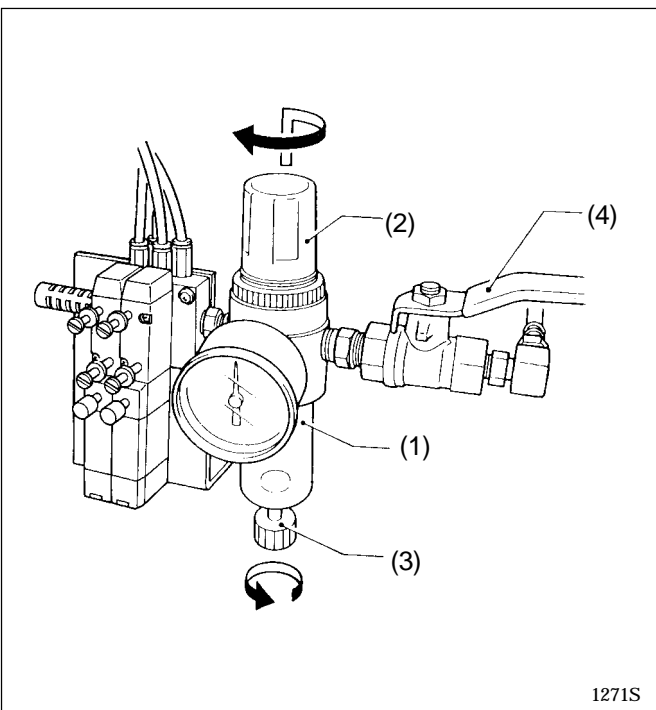

1. Air pressure should be 0.5 MPa.
The air pressure can be adjusted by pulling up and turning the control knob (2) on the integrator (1).
After adjustment is complete, push the control knob (2) downward to lock it.
2. If water stands in the bottle of the integrator (1), turn the drain cock (3) in the direction indicated by an arrow to drain the water.

Note

Open the air cock (4) slowly.

9-11. Adjusting the needle up stop position

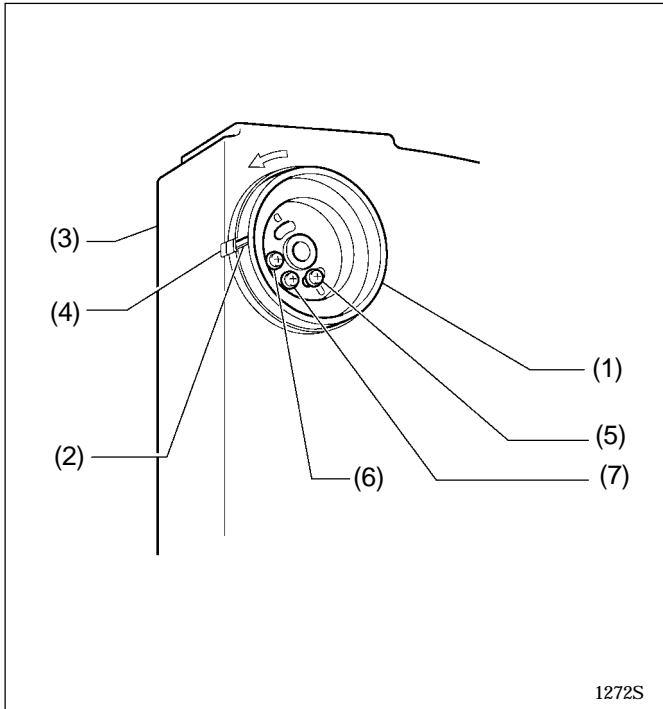

The needle up stop position is adjusted so that the index mark (2) on the machine pulley (1) is inside the mark (4) on the belt cover (3).

If adjustment is necessary, loosen the screw (5) at the "U" mark of the machine pulley (1) and adjust the position of the machine pulley (1). The machine pulley (1) stops later if it is turned clockwise, and it stops earlier if it is turned counterclockwise.

Note

- The screw (6) is used by the needle down detection function and should not be loosened.
- The screw (7) is a screw for detecting the machine stop position, and should not be loosened.
- If the index mark (2) is not inside the mark (4) when be displayed (when memory switch No.14 is on). Turn the machine pulley to move the index mark (2) to the correct position and then start the sewing machine.

9-12. Checking the input sensor and DIP switch input

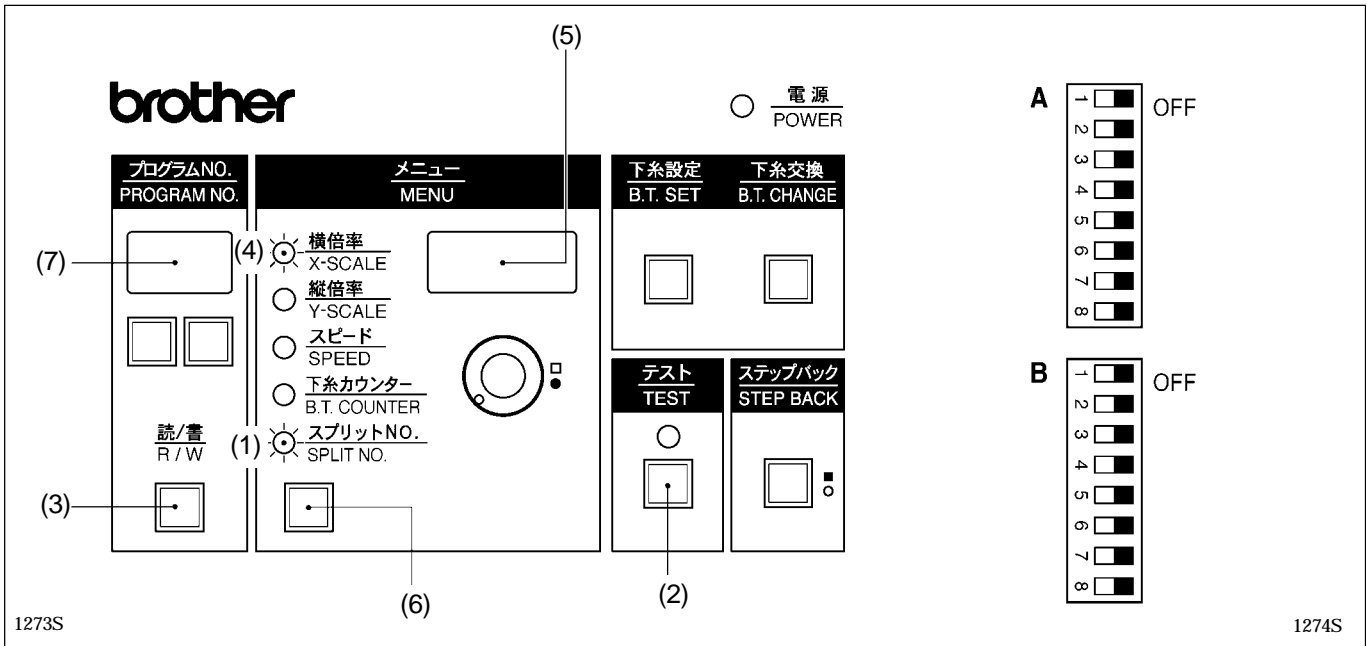

1. When the SPLIT NO. indicator (1) is illuminated and the R/W switch (3) is pressed while the TEST switch (2) is being pressed, the X-SCALE indicator (4) will illuminate and the state of the X home position signal will appear on the display screen (5).

■ When sensor is ON



1282S

■ When sensor is OFF



1283S

2. Each time the MENU switch (6) is pressed, a different indicator will illuminate and the operating condition for the corresponding item will appear on the display screen.

- When X-SCALE indicator is illuminated : X home position sensor
- When Y-SCALE indicator is illuminated : Y home position sensor
- When SPEED indicator is illuminated : Needle up signal (synchronizer)
- When B.T. COUNTER indicator is illuminated : 24-section signal (synchronizer)
- When SPLIT ON. indicator is illuminated : Needle down signal (synchronizer)

3. If the settings for DIP switch A at the side of the operation panel are changed at this time, the number of the changed switch will appear in the top row of the program number display (7).

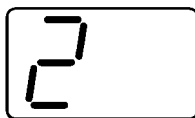

1284S

4. If the settings for DIP switch B are changed at this time, the number of the changed switch will appear in the bottom row of the program number display (7).

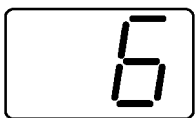

1285S

5. Press the TEST switch (2). The display will return to normal.

Note

You need to move the DIP switch while the power is still turned on in order to check the DIP switch operation. However, the power must always be turned off before DIP switch settings can be changed.

9-13. Checking the input voltage

1. Turn on the power switch.
2. Press the menu switch (1) until the X-SCALE indicator (2) illuminates.

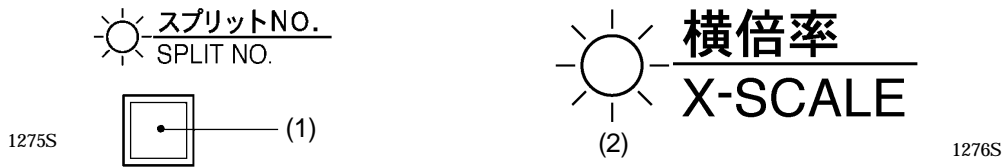

3. While pressing the TEST switch (3), press the R/W switch (4)



4. If the input voltage is normal, the input voltage conditions will be shown in the display as indicated at right.

200-V specifications	090 - 110	"100" is displayed when the input voltage is 200 V.
200-V specifications	100 - 120	
200-V specifications	105 - 125	"110" is displayed when the input voltage is 100 V (for 100-V specs.), 380 V (for 380-V specs.).
100-V, 380-V, 400-V	100 - 120	

5. Press the TEST switch (3) once more to return the display to the normal condition.

9-14. Clearing all memory settings

If the sewing machine stops operating normally, the cause may be that an incorrect memory setting may have been made by means of the memory switch, for instance. In such cases, carry out the following procedure to clear the memory, and also check the DIP switch settings.

While pressing the R/W switch (1), turn on the power. This will clear all of the memory setting.

Note

This operation causes memory switch settings to be returned to their initial settings, and also clears all contents of the memory such as sewing datas.

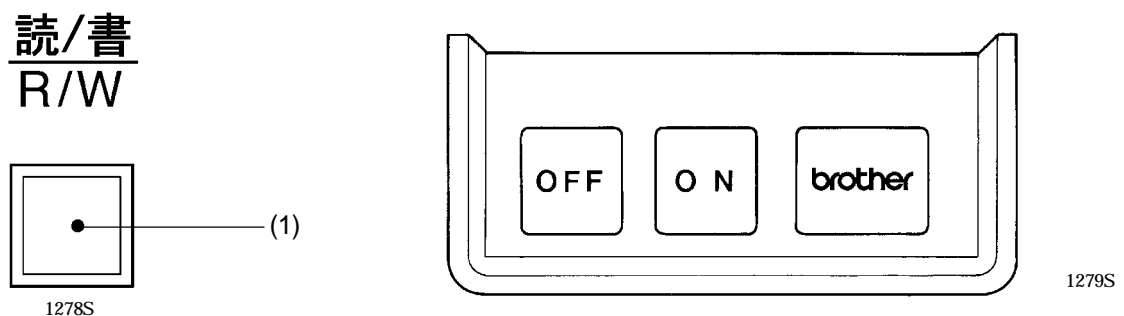

10. DIP SWITCH

Note

All DIP switches are set to OFF at the time of shipment.
 When changing DIP switch, the power must be off.

10-1. Panel DIP switch functions

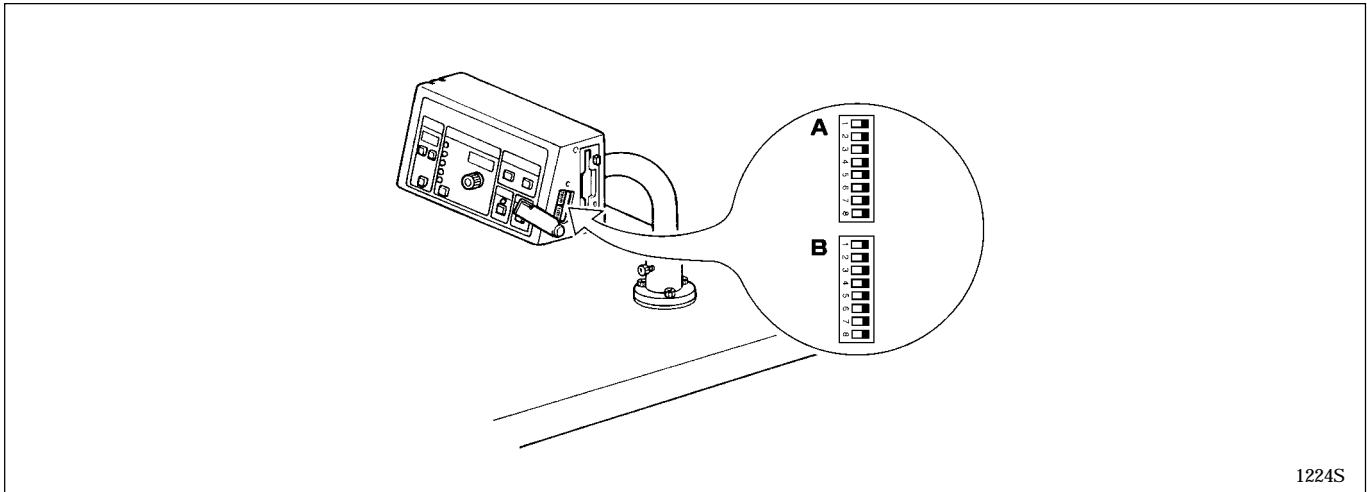

1224S

DIP switch A

SW No.	When ON
A-1	After sewing is complete, the work clamp is raised by the operator and does not rise automatically.

- Various setting combinations for DIP switch No. 2, No. 3 and No. 4 can be used to change the way the work clamp is raised and lowered.
- For Air-type work clamps, the operation mode can be changed using the two-stage work clamp switch.

SW A-2	SW A-3	SW A-4	Type	Function of work clamp pedal
-	-	-	Solenoid/Pneumatic	Work clamp and presser foot rise and lower simultaneously.
ON	-	-	Solenoid/Pneumatic	Only work clamp rises and lowers; presser foot lowers when starting switch is pressed.
-	ON	-	Air	For split-type presser foot, the left/right order changes alternately.
ON	ON	-	Air	Only work clamp rises and lowers; presser foot lowers when starting switch is pressed.
-	-	ON	Air	Work clamp and presser foot rise and lower simultaneously.
ON	-	ON	Air	Lowers in the order right work clamp, left work clamp, presser foot; reverse order when rising.
-	ON	ON	Air	Lowers in the order left work clamp, right work clamp, presser foot; reverse order when rising.
ON	ON	ON	Air	Lowers in the order left and right work clamp, presser foot; reverse order when rising.

DIP switch A

SW No.	When ON
A-5	After sewing is completed, work clamp does not automatically rise (only in split mode)
A-6	Clamping force output is produced (Inner clamping device available as an option)
A-7	Single-pedal operation using the starting switch; when the starting switch is pressed, the work clamp drops, and when it is released, sewing starts.
A-8	Thread breakage detector device is activated (available as an option)

DIP switch B

SW No.	When ON
B-1	Single split mode activated
B-2	BAS-311F-L: The sewing area in the X direction is extended to 230 mm from 220 mm.*
B-3	Thread is not trimmed after an emergency stop.
B-4	Needle cooler output is produced.
B-5	When a rotating-type thread breakage detector device is used, detection precision is increased from 8 to 14. When a fiber-type thread breakage detector device is used, detection precision is increased from 5 to 10.
B-6	Fiber-type thread breakage detector device is ON, and DIP switch A - 8 is ON (available as an option)
B-7	When using a 3-stage pedal If DIP switch A -2 is ON at the same time, the presser foot will drop at the same time that both work clamps drop.
B-8	Feeding speed is switched to high speed.

* <BAS-311F-L only>

If using the work clamp and sewing data for the older BAS-311EL model, set DIP switch B -2 ON.

The BAS-311 L-type has a different length for the sewing area in the X direction (X=220 mm).

Old BAS-311EL X -100 mm ← → +120 mm

New BAS-311F-L X -110 mm ← → +110 mm

Note

The break of the sewing pattern is apt to occur in the extended sewing area.

10-2. DIP switches inside the control box

DANGER



Wait at least 5 minutes after turning off the power switch and disconnecting the power cord from the wall outlet before opening the face plate of the control box. Touching areas where high voltages are present can result in severe injury.

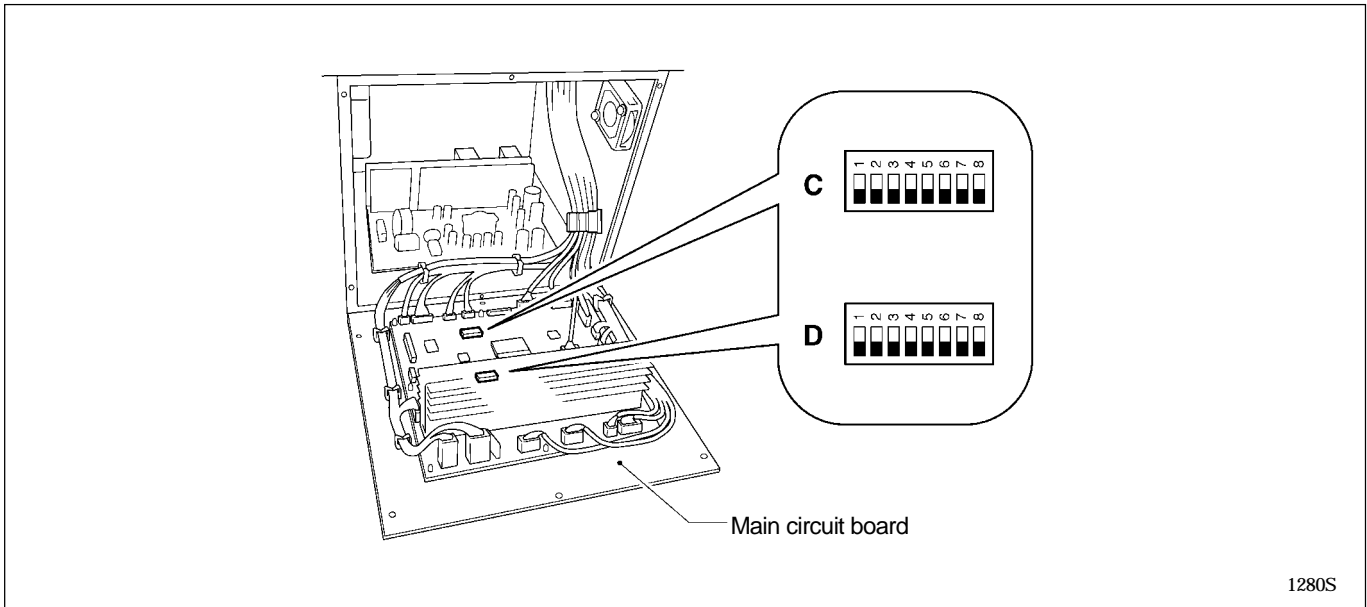

DIP Switch C

SW No.	When ON
C-1	-
C-2	-
C-3	-
C-4	Controlled sewing area becomes 1200 mm X 400 mm
C-5	For pneumatic type, set to ON when the connection has been changed so that the work clamp remains raised when the power is turned off.
C-6	When using an air-driven intermittent work clamp
C-7	-
C-8	-

DIP switch D

SW No.	When ON
D-1	The first two stitches at the sewing start will be sewn at low speed (approx. 260 rpm)
D-2	The last two stitches at the sewing end will be sewn at low speed (approx. 260 rpm)
D-3	-
D-4	The last two stitches at the sewing end will be sewn at low speed (approx. 700 rpm)
D-5	-
D-6	Slow-speed sewing at the sewing start will be canceled
D-7	When the upper shaft is stopped, the motor will change direction and the needle bar will return to the vicinity of the needle up stop position*
D-8	During an emergency stop, the thread is trimmed and the needle bar stops in the raised position.

- * When the motor operates in reverse to raise the needle, the thread take-up will stop at a position which is lower than its normal stopping position. As a result, the thread take-up will rise slightly at the sewing start, and this may result in the thread pulling out under certain conditions.

11. CHANGING SPECIAL FUNCTIONS AND USING THE MEMORY SWITCHES

The functions of the switches on the operation panel can be changed to carry out special functions.

* All of the memory switches are set to OFF at the time of shipment.

Note

The following are special uses. All of the memory switch is usually set to OFF.

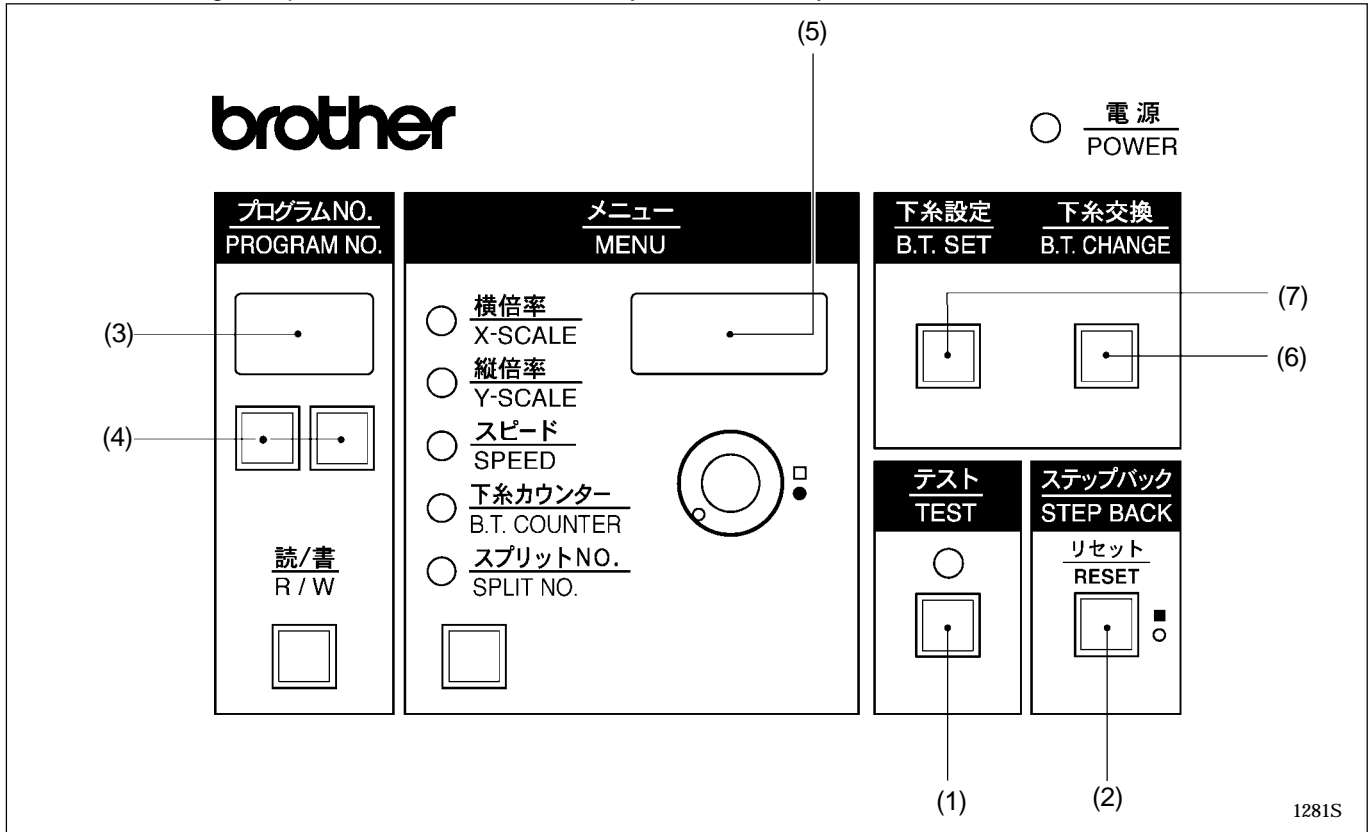

1. Turn on the power switch.
2. While pressing the TEST switch (1), press the STEP BACK switch (2) to switch to setting mode.
3. Press the program select switch (4) so that the number displayed on the display screen (3) matches the switch number (00 - 3F) for the function that you would like to select from the table.
4. Press the STEP BACK switch (2) to switch the setting appearing in the display screen (5) from OFF to ON.

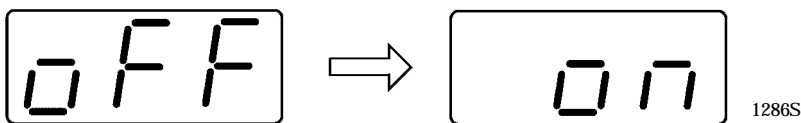

If pressed once more:

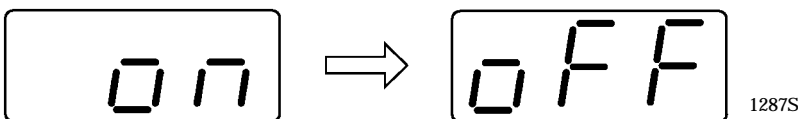

If the B.T. CHANGE switch (6) is pressed at this time, all memory switch settings will be changed to OFF.

5. Press the TEST switch (1). The display will return to normal.

Note

The following steps set the memory switch settings separately for each program number.

6. Once the program data has been read from the floppy disk, change to memory switch setting mode and then press the B.T SET switch (7). The buzzer will sound twice, and the current memory switch settings will be written to the floppy disk.

Memory switches (00 - 0F)

Switch No.	When ON
memo-00	When moving to the home position, the feed plate moves in the order X→ Y and the start position moves in the order Y →X.
memo-01	When moving to the home position, the feed plate moves in the order Y→ X and the start position moves in the order X→Y.
memo-02	The forward position becomes the home position, and movement is in the order Y→ X and X → Y. Use when there is an obstacle at the center of the work clamp.
memo-03	Eject device operates. (Eject device is available by special order.)
memo-04	Needle stops in up position during emergency stop. (Needle normally stops in down position.)
memo-05	When sewing is finished, the feed plate moves via the machine home position to the start position.
memo-06	After the final stitch, the work clamp rises and then the feed plate returns to the start position.
memo-07	Intermittent work clamp is not used (does not rise).
memo-08	When using an inner clamping device, the clamping presser is ON for 1/4 and OFF for 3/4 of the pattern. (Inner clamping device is available as an option.)
memo-09	Changes the wiper to air drive. (Air wiper is available as an option.)
memo-0A	Jog feeding becomes faster during programming.
memo-0b	ON when a two-stage tensioner is used. (Two-stage tensioner is available as an option.)
memo-0c	Single-pedal operation by means of two-stage work clamp switches. DIP switch A-2 is ON
memo-0d	Clearing the emergency stop switch action is carried out using the STEP BACK switch. Note: The factory default setting is ON, and it changes to ON when all memory settings are cleared.
memo-0E	Test feeding is carried out at the same speed as normal sewing. (For checking feed operation)
memo-0F	After sewing is finished, the work clamp automatically opens and closes once. (practice operation) If memo-0E is ON, the work clamp opens and closes twice.

11. CHANGING SPECIAL FUNCTION AND USING THE MEMORY SWITCHES

Memory switches (10 - 1F)

Switch No.	When ON
memo-10	Milling device can be used (available as an option)
memo-11	Bobbin thread counter and production counter are adjusted when thread is trimmed.
memo-12	Work clamp is lowered by pressing work clamp first stage switch twice, without using work clamp second stage switch. When DIP switch A-2 is ON, work clamp lowers in the order right → left; when OFF, work clamp lowers in the order left → right. Order is opposite when rising.
memo-13	When work clamp is lowered, the starting switch causes locking; if the switch is released before locking, the work clamp rises When DIP switch A - 2 is ON, work clamp lowers in the order right → left; when OFF, work clamp lowers in the order left → right. Order is opposite when rising
memo-14	Needle up error detected.
memo-15	ON when machine is equipped with signal tower indicator. (This indicator is available by special order.)
memo-16	ON when machine is equipped with thread nipper. (Thread nipper is available by special order.)
memo-17	ON when machine is equipped with reset switch. (Reset switch is available by special order.)
memo-18	Starting switch causes work clamp to drop in order right → left → forward control is in the same order as starting, and for backward control the work clamp rises in the order left → right using work clamp first stage switch (when DIP switch A-2 is ON). When OFF, the left and right orders are reversed.
memo-19	Produces two work clamp signal outputs (right and left work clamp) so that a two-position air valve can be used. (Two-position air valve is available by special order.)
memo-1A	When using a triple pedal (DIP switch B-7 is also ON), the right is used exclusively to detect the home position. If DIP switch A-7 is OFF, the left pedal causes left and right work clamps to be raised and lowered simultaneously. If ON, the left pedal causes the left work clamp to be raised and lowered, and the right work clamp lowers when starting pedal to sew.
memo-1b	KE430B single foot pedal can be used. DIP switch A-7 is ON.
memo-1c	Bobbin thread counter is decremented at the start of sewing.
memo-1d	When using an air pressure drop detection switch. (This detection switch is available by special order.)
memo-1E	Changes the split number automatically by using an external switch. (Use option connector P3 on the operation panel.)
memo-1F	Program number is changed automatically by using outside switch. (Use optional connector P3 on the operation panel.)

Memory switches (20 - 2F)

Switch No.	When ON
memo-20	During feed test operation, jump feeding 100 stitches at a time is possible using the STEP BACK switch.
memo-21	After the home position is detected and the machine moves to the sewing start position, the work clamp rises automatically.
memo-22	When extended option output No. 1 is ON, the sewing machine starts automatically.
memo-23	Set to ON when the bobbin changer is being used. (This part is available by special order.)
memo-24	Feed operation is enabled even if no cassette has been set when the eject device is being used (memo-03 is ON).
memo-25	The enlargement and reduction ratio settings at the operation panel are fixed at the values when memo-25 was set to ON.
memo-26	Thread trimming is not carried out.
memo-27	The sewing speed setting at the operation panel is fixed at the value when memo-27 was set to ON.
memo-28	Set to ON when using the thread take-up device.
memo-29	Work clamp lifting and lower thread winding before home position detection are disabled.
memo-2A	For program numbers 1 to 15, the program number is output to the extension optional outputs 4 to 7.
memo-2b	-
memo-2c	-
memo-2d	-
memo-2E	-
memo-2F	When the input voltage is being checked, the display shows the temperature of the heat sink on the main circuit board instead of the voltage.

Extended option output

Use the programmer (option).

Required controls for pressing motion and automatic stacking of sewing can be implemented according to various functions of the machine.

For detail of the extended option output, please consult with your local Brother Sales Office.

11. CHANGING SPECIAL FUNCTION AND USING THE MEMORY SWITCHES

Memory switches (30 - 3F)

Turn the dial while pressing the STEP BACK switch to change the values.

Switch No.	Possible setting range	Units	Initial Value	Explanation
memo-30	1 - 999	X 10ms	10	Time until feed mechanism starts moving after work clamp has lifted.
memo-31	1 - 4	-	1	Changes the feed speed. 1 (Fast) \longleftrightarrow 4 (Slow)
memo-32	1 - 7	-	3	Changes the possible sewing speed for a given stitch length. 1 (Fast) \longleftrightarrow 7 (Slow) 1 (2,700/3 mm), 2 (2,600/3 mm), 3 (2,500/3 mm), 4 (2,300/3 mm), 5 (2,000/3 mm), 6 (1,800/3 mm), 7 (1,200/3 mm) Settings 1 and 2 are outside the warranty specification at the time of shipment from the factory.)
memo-33	1 - 10	X 7.5°	5	Changes the feed timing. 1 (Fast) \longleftarrow 5 (standard) \longrightarrow 10 (Slow)
memo-34	1 - 5	stitch	1	Number of low-speed stitches sewn at 400 rpm at sewing start.
memo-35	10 - 60	ms	40	Solenoid ON time changes (BAS-311F solenoid specifications only). 10 (Quiet) \longleftrightarrow 60 (High work clamp capacity)
memo-36	1 - 3	-	1	The solenoid ON time when the presser foot is raised changes. (Standard) 1 \longleftrightarrow 3 (Upper limit)
memo-37	0 - 3	-	0	Automatically corrects the gear speed when reading 2DD disks. 0 : No automatic correction 1 : Read as BAS-311A data 2 : Read as BAS-326A data 3 : Read as BAS-341A, 342A data ex. Read BAS-326A data by BAS-311F / Set memo-37=2
memo-38	1 - 20	X 100 ms	1	Changes the length of time from inserting the cassette until automatic starting when the eject device is being used and automatic starting has been set (memo-03 and DIP switch A-7 are also both ON).
memo-39	0 - 11	-	0	Changes the reference point for enlargement and reduction using the operation panel. 0 : Sensor home position 1 : Center of work clamp 2 : Upper-left corner of work clamp 3 : Lower-left corner of work clamp 4 : Upper-right corner of work clamp 5 : Lower-right corner of work clamp 6 : Sewing start point, 7 : Sewing end point 8 : Upper-left corner of sewing pattern 9 : Lower-left corner of sewing pattern 10 : Upper-right corner of sewing pattern 11 : Lower-right corner of sewing pattern
memo-3A	1 - 3	-	2	Changes the speed limit for the given sewing pitch when the maximum speed remains constant. 1 : Speed limit is increased for the given sewing pitch and the sewing speed for that pitch is increased. 2 : Standard 3 : Speed limit is decreased for the given sewing pitch and the sewing speed for that pitch is decreased. Note If sewing slippage occurs in places where a large sewing pitch is used, reduce the setting to 3. Furthermore, sewing slippage may occur in some cases if setting 1 is used.
memo-3b	-	-	0	-
memo-3c	-	-	0	-
memo-3d	-	-	0	-
memo-3E	-	-	0	-
memo-3F	-	-	0	-

12. ERROR CODES

DANGER



Wait at least 5 minutes after turning off the power switch and disconnecting the power cord from the wall outlet before opening the face plate of the control box. Touching areas where high voltages are present can result in severe injury.

If an operation problem occurs, a buzzer will sound and an error code will appear on the display screen; if a programmer is connected, an error message will appear on the screen.

Code	Cause	Remedy
E.10	Emergency stop switch was pressed.	Turn the EMERGENCY STOP switch clockwise and then pull it forward to release it. Press the STEP BACK (RESET) switch on the operation panel.
E.11	Emergency stop switch was pressed.	Turn the EMERGENCY STOP switch clockwise and then pull it forward to release it. Press the STEP BACK (RESET) switch on the operation panel. You can start sewing again, press the STEP BACK switch once more.
E.12	Emergency stop switch is activated or its connection is not correct.	Turn off power and check it.
E.13	Defective connection of model selection connector.	Turn off power and check connector P26.
E.14	Foot switch was depressed, or connection of foot switch is defective.	Turn off power and check it.
E.15	Start switch was depressed, or connection of start switch is defective.	Turn off power and check it.
E.16	Machine head was tilted back.	Turn off power and tilt machine head back.
E.17	Operation panel switch was depressed when power was turned on.	Turn off power and check it.
E.20	Motor malfunctions or synchronizer is not connected correctly.	Turn off power and check machine, synchronizer connection, and connectors P12 P15 P16.
E.21	Motor malfunctioned.	Turn off power and check ground wire connection.
E.22	Needle up stop position error.	Turn pulley to align timing mark with that on belt cover.
E.30	Data exceeds available sewing area due to resize ratio.	Adjust resize ratio.
E.31	Stitch length exceeds 12.7mm due to resize ratio.	Adjust resize ratio.
E.32	No end code in sewing data.	Input end code, or change program No.

12. ERROR CODES

Code	Cause	Remedy
E.40	Floppy disk is not inserted or operation panel cable is not securely connected.	Insert a floppy disk. If floppy disk is already inserted, turn off the power and check the connections of cords inside the operation panel.
E.41	Invalid program No., or no data.	Change program No..
E.43	Different floppy disk!	Use original floppy disk.
E.4F	Error occurred during floppy disk data reading.	Replace the floppy disk and repeat the operation.
E.50	Floppy disk is write-protected.	Release write-protection.
E.51	Insufficient available memory on floppy disk.	Use another floppy disk.
E.52	Can not format this floppy disk.	Change floppy disk.
E.5F	Error occurred during data writing on floppy disk.	Replace the floppy disk and repeat the operation.
E.60	Can not backup data. (Panel PCB)	Turn off power and then clear all of the memory setting.
E.61	Can not backup data. (Control PCB)	Turn off power and then clear all of the memory setting.
E.62	Operation panel error.	Turn off power and then on again.
E.63	Combination of control PROM and operation panel PROM is invalid.	Turn off power and check it
E.70	Same optional output number already exists.	Change optional output number. If not use optional output, turn off power and then clear all of the memory setting.
E.71 - E.74	Bobbin changer error!	See the manual for bobbin changer. If not using the bobbin changer, set memory switch 23 to OFF.
E.75	Milling motor has stopped due to overload.	See the manual for Milling motor. If not use milling motor, set OFF memory switch 10.
E.80	Upper thread has broken. (Rotary type sensor)	Thread upper thread again. You can start sewing again.
E.81	Upper thread has broken. (Optical fiber type sensor)	Thread upper thread again. You can start sewing again.
E.90	Power supply voltage is extremely low.	Turn off power and check voltage.
E.91	Power supply voltage is extremely high.	Turn off power and check voltage.















Code	Cause	Remedy
E.A0	Start switch was pressed when there was no sewing available data.	Read sewing data again.
E.A1	Can not detect home position. X-Y feed or connection of home position sensor is incorrect.	Turn off power and, check X-Y feed and connector P1.
E.c0	Motor PROM is not correctly inserted.	Turn off power and check it.
E.c1	Cooling fan (left one when viewed from front) in control box does not operate.	Turn off power and check it. Check fan connector.
E.c2	Heat-sink on main PCB is overheating.	Turn off power and clean air inlet port.
E.c3	Overcurrent was detected in X pulse motor.	Turn off power and check it.
E.c4	Overcurrent was detected in Y pulse motor.	Turn off power and check it.
E.c5	Cooling fan (right one when viewed from front) in control box does not operate.	Turn off power and check it. Check fan connector.
E.d0	Air pressure has dropped.	If not use detector, set OFF memory switch 1d.
E.E0	Control PROM is not correctly inserted.	Turn off power and check it.
E.E1	Main PCB detected communication error.	Turn off power and then on again.
E.E2	Panel PCB detected communication error.	Turn off power and then on again.
E.E3	Incorrect connection of cable between operation panel and control box.	Turn off power and check it.
E.F0	Solenoid is short-circuited (malfunction of main circuit board) or power supply relay is not operating (malfunction of power supply circuit board).	Turn off power and check it.
E.F1	Incorrect connection of cable between power supply PCB and main PCB.	Turn off power and check connector P20.
E.F2	Over current at power supply PCB.	Turn off power and check it.

REFERENCE segment LED alphabet







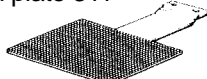







	Panel display	A	b	c	d	E	F	6	H	L	o
	Text display	A	B	C	D	E	F	6	H	L	O

13. GAUGE PARTS LIST ACCORDING TO SUBCLASSES

The following parts are available for adding further flexibility to the range of applications.

Subclass	BAS-311F-0			BAS-311F-0,-L	
	1S, 4S	2A	3A	1A, 4A	
Part name/ Specification	Heavy materials (Solenoid type)	Medium materials (Pneumatic type)	Extra heavy materials (Pneumatic type)	Heavy materials (Pneumatic type)	
Needle hole plate 0182Q 	(φ 2.2) S10213-001 F		(φ 4.0) S34348-001 M	(φ 2.2) S10213-001 F	
Bobbin case assy 0183Q 	S59221-001 LC		S59222-001 LD	S59221-001 LC	
Tension spring 0184Q 	S48664-001 AN		S16075-101 B	S48664-001 AN	
Screw 0185Q 	S16492-101				
Spring, antispin 0186Q 	S15667-001				
Bobbin 0187Q 	S15665-001 LA		S15666-001 LB	S15665-001 LA	
Inner rotary hook assy 0188Q 	SA1890-001 LG	SA2173-001 LF	SA1890-001 LG		
large shuttle hook 0189Q 	152686-101 B	152682-101 A	152686-101 B		
Tension spring 0190Q  Sub  Main 1640S	SA2900-001		107606-001	SA2900-001	
	107606-001	104525-001	S06548-001	107606-001	
Spring 0191Q 	144588-001 B	145519-001	144588-001 B		
Needle bar thread guide 1639S  A  B	S02438-001 A		S02439-001 B	S02438-001 A	
Needle assy 0193Q 	SA1645-019	SA1752-016	SA1645-025	SA0165-019	
	DP X 17#19 145646-019	DP X 5#16 107415-016	DP X 17#25 145646-025	DP X 17#19 145646-019	
Presser foot 1288S 	S42843-001 A		S42844-001 B	S42843-001 A	
Feed plate 311 1289S 	S55163-001 B	S55162-001 A	S55163-001 B	BAS-311 F-0 S55163-001 B	BAS-311 F-L S55941-001 LB

13. GAUGE PARTS LIST ACCORDING TO SUBCLASSES

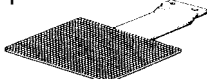
Subclass	BAS-326F-0		
	1A	2A	4A
Part name/ Specification	Heavy materials	Medium materials	Heavy materials
Needle hole plate 0182Q 	(φ 2.2) S10213-001 F		
Bobbin case assy 0183Q 	S59221-001 LC		
Tension spring 0184Q 	S48664-001 AN		
Screw 0185Q 	S16492-101		
Spring, antispin 0186Q 	S15667-001		
Bobbin 0187Q 	S15665-001 LA		
Inner rotary hook assy 0188S 	SA1890-001 LG	SA2173-001 LF	SA1890-001 LG
large shuttle hook 0189Q 	152686-101 B	152682-101 A	152686-101 B
Tension spring 0190Q  Sub  Main 1640S	SA2900-001		
Spring 0191Q 	144588-001 B	145519-001	144588-001 B
Needle bar thread guide 1639S  	S02438-001 A		
Needle assy 0193Q 	SA1645-019 DP X 17#19 145646-019	SA1752-016 DP X 5#16 107415-016	SA1645-019 DP X 17#19 145646-019
Presser foot 1288S 	S42843-001 A		
Feed plate 311 1289S 	S55953-001 B	S55952-001 A	S55953-001 B

14. TROUBLESHOOTING

Problem	Cause	Check	Remedy	Page
Presser does not rise.	Work clamp operation is sluggish.	Sliding part of the work clamp lubrication	Grease the sliding part of the work clamp.	/
	Presser lifter air tube is bent or damaged.*	Presser lifter air tube	Straighten the bend in the tube or replace the tube.	18
	Presser lifter link is not moving back.	Link return spring is unhooked.	Hook the link return spring properly.	/
Presser does not drop.	Work clamp operation is sluggish.	Sliding part of the work clamp lubrication	Grease the sliding part of the work clamp.	/
	Presser lifter air tube is bent or damaged.*	Presser lifter air tube	Straighten the bend in the tube or replace the tube.	18
Presser lift amount is incorrect.	Incorrect position of presser arm lever F.	Distance between work clamp and top of needle plate	Adjust the work clamp lift amount.	49
Solenoid-type work clamp lifts up without clamping the material.	Work clamp pressure is too light.	Check the setting of the memory switch (memo-35).	Increase the setting value of the memory switch (memo-35).	62
Thread wiper does not operate correctly.	The thread wiper is obstructing the needle.	Clearance between thread wiper and needle tip	Adjust the height of the thread wiper.	48
	Thread wiper position is incorrect.	Thread wiper position	Adjust the operating distance of the thread wiper.	48
Lower thread winds to one side.	Bobbin winder thread tension stud heights is incorrect.	Bobbin winder thread tension stud height	Adjust the height of the thread tension stud.	23
Lower thread winding amount is incorrect.	Bobbin presser position is incorrect.	Thread winding amount	Adjust the position of the bobbin presser.	23
Thread slips out of the needle.	Stitches being skipped at the sewing start.	Refer to "Skipped stitches occur".	Refer to "Skipped stitches occur".	/
	Uneven upper thread length.	Upper thread length	Adjust the sub-tension.	25
	Position of shuttle race thread guide is incorrect	Position of shuttle race thread guide	Adjust the position of the shuttle race thread guide	43

* For Air type

Problem	Cause	Check	Remedy	Page
Upper thread breaks.	Upper thread tension is too strong.	Upper thread tension	Adjust the upper thread tension.	25
	Needle is installed incorrectly.	Needle direction	Install the needle so that the groove is facing forward.	21
	Thread is too thick for the needle.	Thread and needle	Use the correct thread for the needle.	21
	Thread take-up spring tension and height are incorrect.	Thread take-up spring tension and height	Adjust the tension and height of the thread take-up spring.	25
	Damaged or burred rotary hook, needle hole plate or needle.	Damage or burring	File smooth or replace the affected part.	
	Thread melting (synthetic thread)	Thread edge	Use a thread cooling device.	21
	Thread path is incorrect.	Thread	Pass the thread correctly along the thread path.	22
Lower thread breaks.	Lower thread tension is too strong.	Lower thread tension	Adjust the lower thread tension.	25
	Corners of needle hole plate or bobbin case are damaged.	Damage	File smooth or replace the affected part.	
Skipped stitches occur.	Clearance between needle and rotary hook tip is too great.	Needle clearance	Adjust the needle clearance. the affected part.	43
	Incorrect needle and rotary hook timing.	Needle bar lift amount	Adjust the needle bar lift amount.	42
	Driver is contacting needle more than is necessary.	Clearance between driver and needle	Adjust the driver needle guard.	43
	Needle is bent.	Bent needle	Replace the needle.	
	Needle is installed incorrectly.	Needle direction	Install the needle so that the groove is facing forward.	21
Needle breaks.	Needle is touching the rotary hook.	Needle clearance	Adjust the needle clearance. the groove is facing forward.	43
		Needle bar lift amount	Adjust the needle bar lift amount.	42
	Needle is bent.	Bent needle	Replace the needle.	
	Needle moves about.	Needle and thread	Select the correct needle for the sewing conditions. Reduce the sewing speed	21
	Needle is too thin.	Needle and thread	Use the correct needle for the material.	

14. TROUBLESHOOTING

Problem	Cause	Check	Remedy	Page
Upper thread is not trimmed.	Fixed knife is blunt.	Fixed knife blade	Sharpen or replace the fixed knife.	
	Movable knife does not pick up the thread.	Shuttle race thread guide position	Adjust the position of the shuttle race thread guide.	43
		Needle bar lift amount	Adjust the needle bar lift amount.	42
	The movable knife does not pick up the thread because of skipped stitches at the sewing end.	Skipped stitches at sewing end	Refer to "Skipped stitches occur".	
	Movable knife position is incorrect.	Movable knife position	Adjust the position of the movable knife.	44
Sub-tension is too weak.	Sub-tension	Turn the sub-tension nut to adjust the tension.	25	
Thread jamming.	Thread take-up spring tension and height are incorrect.	Thread take up spring tension and height	Adjust the tension and height of the thread take-up spring.	25
	Incorrect needle and rotary hook timing.	Needle bar lift amount	Adjust the needle bar lift amount.	42
	Shuttle race thread guide is not separating the threads.	Shuttle race thread guide position	Adjust the position of the shuttle race thread guide.	43
Poor seam finish on reverse side of material.	Shuttle race thread guide is not separating the threads.	Shuttle race thread guide position	Adjust the position of the shuttle race thread guide.	43
	Upper thread is not properly tight.	Upper thread tension	Adjust the upper thread tension.	25
	Uneven upper thread length.	Upper thread length	Adjust the sub-tension.	25
Incorrect thread tightness.	Upper thread tension is too weak.	Upper thread tension	Adjust the upper thread tension.	25
	Lower thread tension is too weak.	Lower thread tension	Adjust the lower thread tension.	25
	Thread take-up spring tension and height are incorrect.	Thread take up spring tension and height	Adjust the tension and height of the thread take-up spring.	25

Problem	Cause	Check	Remedy	Page
Unstable upper thread length	Improper tension and height of thread take-up spring	Thread take-up spring tension and height	Adjust the tension and height of the thread take-up spring.	25
	Improper adjustment of sub tension	sub tension	Adjust the sub tension.	/
	Needle up stop position fluctuates.	See "Unstable needle up stop position".	←	/
	Fixed knife is blunt.	Fixed knife blade	Sharpen or replace the fixed knife.	/
Unstable needle up stop position	Electrical trouble	Refer to the details for [E.22] in the error code table.	←	63
Machine does not operated when power is turned on and foot switch is depressed.	Head position switch does not work.	Head position switch cord connection.	Check if the cord is disconnected.	11 • 13
		Switching plate position.	Adjust the position of the switching plate.	7
		Head position switch is broken.	Replace the head position switch.	/

15. OPTIONS

Programmer	Used to create sewing patterns for the BAS-300F series. It can also be used to display error messages.
Inner clamp device	Used for efficient sewing around labels, emblems and tape; operates by air together with the outer presser, so material slip pages will not occur.
One-touch clamping device	Allows the clamp to be replaced quickly and easily, without the need for extra tools. The positioning adjustment that has been previously required for other clamps is no longer necessary.
Milling device	This device can be used to cut a variety of objects such as grooves, holes, and outline shapes in plastic or aluminum sheets. This device is available by special order. Please contact your nearest Brother dealer.
WP stitch device	Increases the stitch creation range for perfect stitches.
Automatic bobbin changer	When the amount of bobbin thread remaining becomes low, this device automatically replaces the bobbin. This reduces the need for tasks such as checking the amount of bobbin thread remaining and replacing bobbins, so that productivity can be increased.
Snap fastener and hook attachment device	This attachment is for holding snap fasteners and hooks.
Needle thread presser device	This allows the upper thread to be securely placed under the material for the first stitch at the sewing start.
3-Pedal foot switch	In addition to a start pedal, the right and left pedals operate independently which allows positioning with even greater precision.
2-step presser foot device	When there is difference in thickness of a work piece within one pattern, for example, when the work piece includes joints to be sewn, the 2-step presser foot device changes the height of the presser foot in your desired position. This prevents stitches from skipping and ensures that high sewing quality is always maintained.
Thread breakage detector device	Available as rotary type or fiber type, stops sewing when a thread breakage is detected and warns the operator.

Needle cooler device	This is a pneumatic-type needle cooler which prevents the thread breaking due to heat. It is particularly useful when sewing thicker materials at high sewing speeds.
OT (One-touch) Presser	Use according to particular sewing needs in order to provide an even clamping force.
Soft presser	At the first stage, the work clamp applies only a spring force so that the material can be positioned. Then at the second stage, air pressure provides a full clamping force.
Cassette presser	This allows the operator to hold two clamps so that the preparation for the next operation can be carried out while sewing is in progress. Overlapping operations are thus possible, which can greatly boost productivity.
Play prevention work clamp	This work clamp prevents any play from occurring in the clamp.
Thread wiper, side type	Wipes the upper thread away to the side when an inner clamping device is being used.
Air wipper device	The thread wiper is driven by a pneumatic cylinder.
2-step thread tension device	Allows the upper thread tension to be switched between two settings at any position desired by using the programmer.
Thread take-up device	After the thread is trimmed, an upper thread trailing length, which is handy when sewing light materials where normal trailing thread lengths can often lead to the thread pulling out. (311F series: Solenoid type, 326F: Pneumatic type)
Automatic ejector	When the reflective plate of the cassette is detected by the sensor, the cassette is held automatically by a pneumatic cylinder. In addition, the programs can be set so that the cassette is ejected automatically.

* Refer to the separate Parts Book for details.

brother[®]

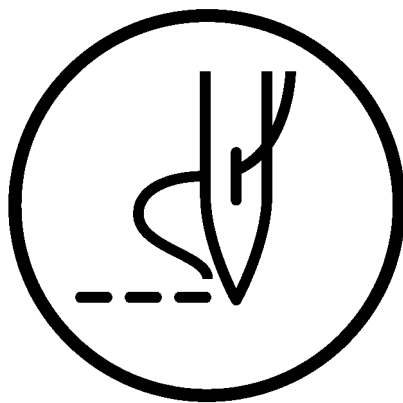

INSTRUCTION MANUAL

BROTHER INDUSTRIES, LTD.

15-1, Naeshiro-cho, Mizuho-ku, Nagoya 467-8561, Japan. Phone: 81-52-824-2177

Printed in Japan

BAS-311F
SA3024-001
2003.08.H (1)